

10 Watt 6V6

Push-Pull Vacuum Tube Amplifier



Class AB Mono Power Amp

T.O.C.

T.O.C.....	2
Introduction.....	3
DISCLAIMER.....	3
Circuit Design History.....	5
Tube History.....	6
12AU7.....	6
5Y3G.....	6
6V6.....	7
6AU6.....	7
Component Layout.....	8
Power Supply Schematic.....	10
Amplifier Schematic.....	11
Parts list.....	12
Chassis Sides Construction.....	14
Chassis Wiring.....	15
Vacuum Tubes Data Sheets.....	16
12AU7.....	16
5Y3G.....	18
6V6.....	19
6AU6.....	21
Audio Specifications.....	23
Power Output.....	23
Just Before Ringing Starts 8.46 Watts.....	23
Max Output 13.73 Watts.....	23
Max Input Level 509 MV.....	24
Input Impedance.....	24
Output Impedance: 8 Ohm.....	24
Maximum Gain is: 23.....	24
THD+N Total Harmonic Distortion + Noise.....	24
Band Width (Frequency Response) 30hz to 20khz,.....	24
Tools Used for This Project.....	27
Conclusion.....	28
About Me.....	29

INTRODUCTION

Last time I was touched vacuum tubes was around 1967 when I was repairing radios and TV. I remember this old radio HIFI that was stripped from a console back in the early 60s There was a 12 inch speaker and a smaller speaker I think mid range and a small sealed back cone tweeter. There was a huge power transformer on the chassis and a bunch of tubes. I do not remember what the output tubes were but I do remember them being in a push pull configuration. The sound was amazing and through out the years that followed I was never able to match the sound quality with all of the solid state amps I have built or heard. Recently with the hype on the vacuum tube single ended amp hoopla I started getting the bug and turned to the internet for research.

The transistor brought a new possibilities in the amplifier and speaker industries. The one current practice in solid state amps is to through a lot of current at a speaker in a small sealed cabinet. I will not debate with anyone about lots or little power and how they sound.

I want to build a tube power amplifier to see if I can find that good sound I heard when I was young. The following document contains the tube amp I chose as my project. Please note that I have never liked single ended power supplies for audio amps, so it was not used.

DISCLAIMER

While this document describes a plan to build an electronic device which has about 360 volts DC under the chassis caution must be followed. I will not be held responsible for any injuries incurred from some one following this document.

MSH MODEL-1 POWERAMP (Michael S. Holden) make no representations about the suitability of this information for any purpose. It is provided "as is"

MSH MODEL-1 POWER AMP (Michael S. Holden) disclaims all warranties with regard to this information, including all implied warranties of merchantability and fitness, in no event shall MSH MODEL-1 POWERAMP (Michael S. Holden) be liable or any special, indirect or consequential damages or any damages whatsoever resulting from loss of use, data or profits, whether in an action of contract,

negligence or other tortuous action, arising out of or in connection with the use or performance of this information.

This information may include technical inaccuracies or typographical errors.

MSH MODEL-1 POWERAMP (Michael S. Holden) may make improvements and/or changes in the information at any time.

CIRCUIT DESIGN HISTORY

The origin of the power amplifier design came from the schematic below, which came from the 1959 RCA RECEIVING TUBE MANUAL Tech Series RC-19

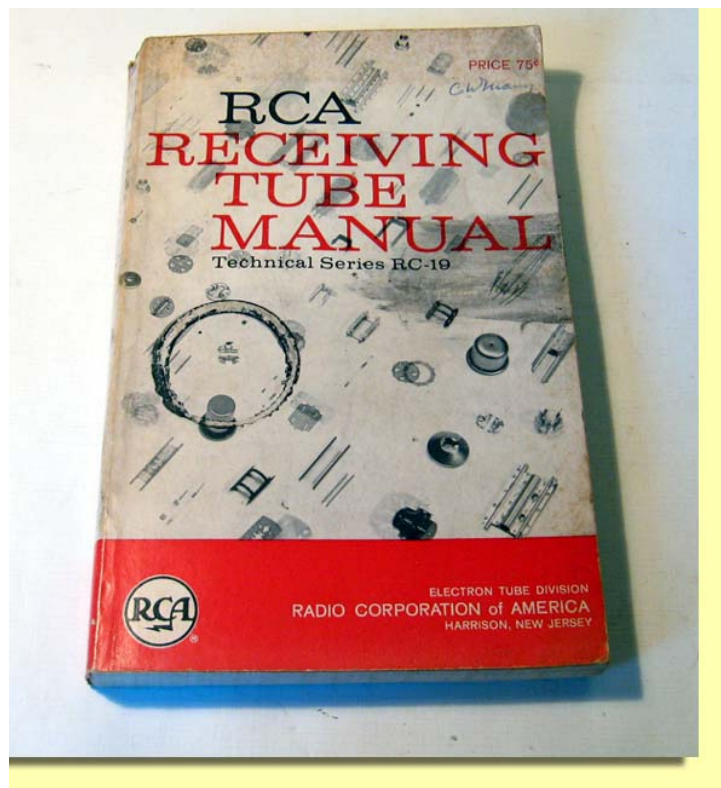
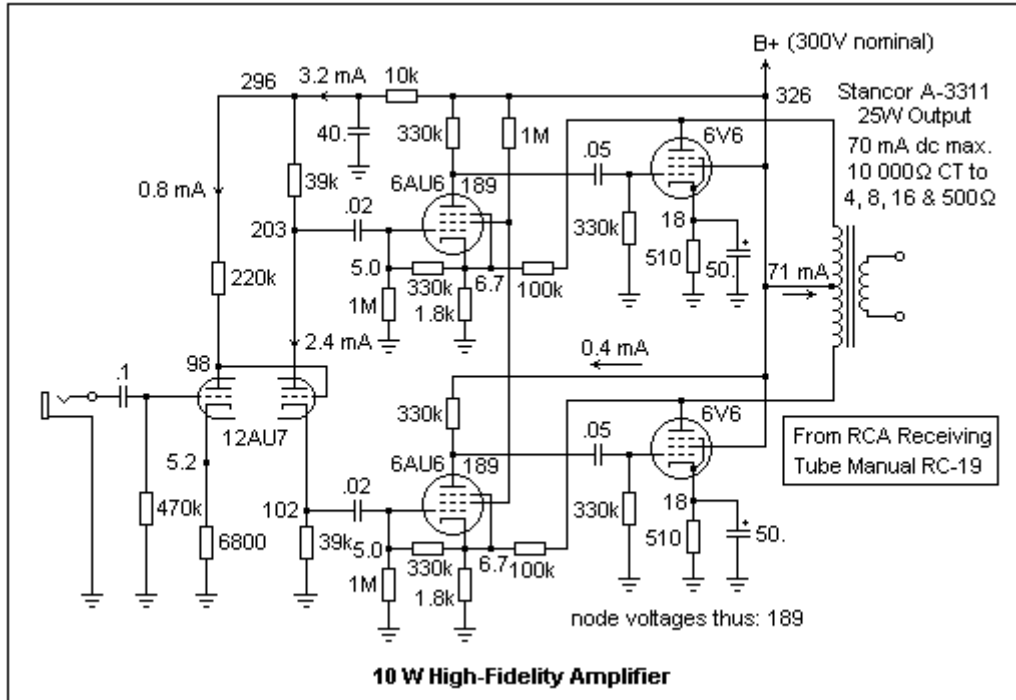

TUBE HISTORY

12AU7

12AU7 is a miniature 9-pin medium-gain dual triode vacuum tube. It belongs to a large family of dual triode vacuum tubes that share the same pin out (EIA 9A). 12AU7 is also known in Europe under its Mullard-Philips tube designation ECC82. Base for this valve is B9A

The tube is popular in hi-fi vacuum tube audio as a low noise line amplifier, driver and phase-inverter in vacuum tube push-pull amplifier circuits. There are opinions which indicate that this popularity is caused by audiophile industry/media polarization, not by its performance.

The tube has a center tapped filament so it can be used in either 6.3V 300mA or 12.6V 150mA heater circuits.

Current production of 12AU7 takes place in Russia, Slovakia, Serbia and China.

5Y3G

The 5Y3 is a medium-power directly-heated rectifier vacuum tube introduced by RCA in 1935. It has found wide use in tube radios and early guitar amplifiers (of the Fender Champ type.) It is virtually identical, electrically, to the 4-pin type 80 tube, but with an octal base.

The success of the 80 and 5Y3 led to the development of many similar rectifier tubes of both higher and lower power ratings, including the 5V3, 5W3, 5X3, 5Z3, 5U4, and 5Z4. The epitome might have been the 3DG4 of the 1960s, with a full 240 milliamp capability.

Currently, a plug-in replacement is being manufactured by Sovtek in Russia, which is has very similar specifications, but is indirectly-heated, and can support currents up to 144 mA, versus the 120 mA of the original. However the Sovtek 5Y3 is not a true 5Y3. It drops less voltage than vintage 5Y3's, and may cause voltages to run too high.

6V6

6V6 is the designator for a vacuum tube introduced by Radio Corporation of America RCA United States in late 1937.

6V6 is a beam-power tetrode, similar to its predecessor the 6L6. While the 6L6 was an excellent tube, it was not suitable for use in consumer electronic devices because it required a lot of input power and hence a large, hot, and expensive power supply, and generated far more output power than required, especially in a distortion-reducing push-pull pair. With the introduction of the lower-powered 6V6, which required only half the heater power of the 6L6, the beam-power tetrode became a usable technology for the home, and became common in the audio output stage of radios and audio amplifiers where power pentodes such as the 6F6 had previously been used. The 6V6 required less heater power and produced less distortion than the 6F6, while still offering higher output in both single-ended and push-pull configurations.

6AU6

AND NOW A NEW FEATURE (drumroll). Welcome to MEET THE TUBE, an in-depth investigation of a specific tube in common use by all of us tube-set fans. This issue we get to know and love the ever-popular 6AU6 and 6AU6-A. The 6AU6 is a miniature-type tube used in radio equipment as an RF amplifier. It is most often found in high-frequency, wide-band applications, but it is occasionally used as a limiter tube in some FM equipment. What makes a 6AU6-A out of a 6AU6 is the addition of a controlled heater warm-up time (usually around 11 seconds) for use in applications employing series-connected heater strings. The 6AU6 makes its home in a seven-pin miniature socket, and it can be operated in any position, making it desirable for portable and mobile applications. This tube can be found in applications with or without external shielding. In some cases, the external shield is connected to the cathode. This will affect interelectrode capacitances when the tube is used with a triode connection. Tubes of this type are most commonly referred to as "sharp cut-off pentodes."

COMPONENT LAYOUT

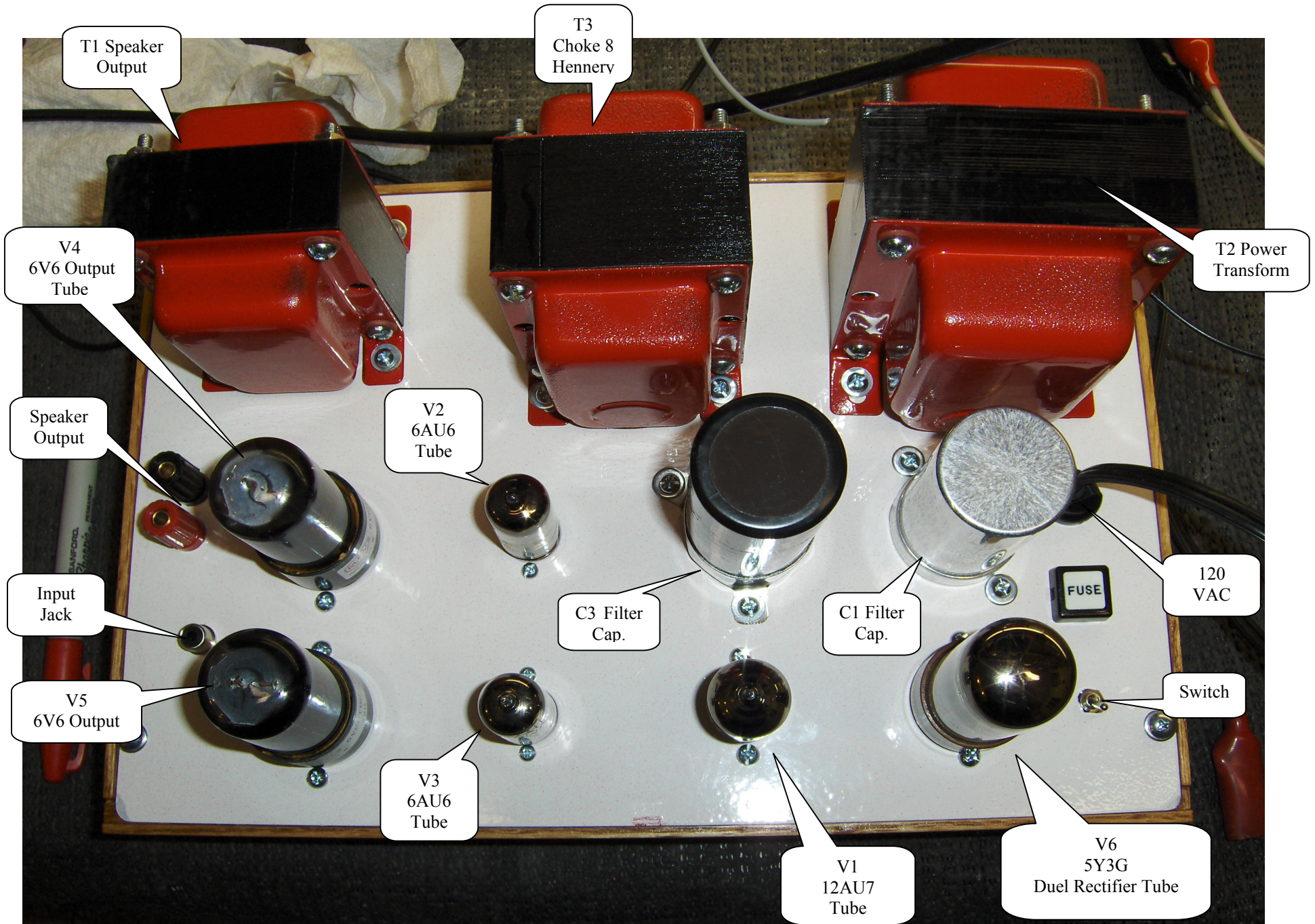

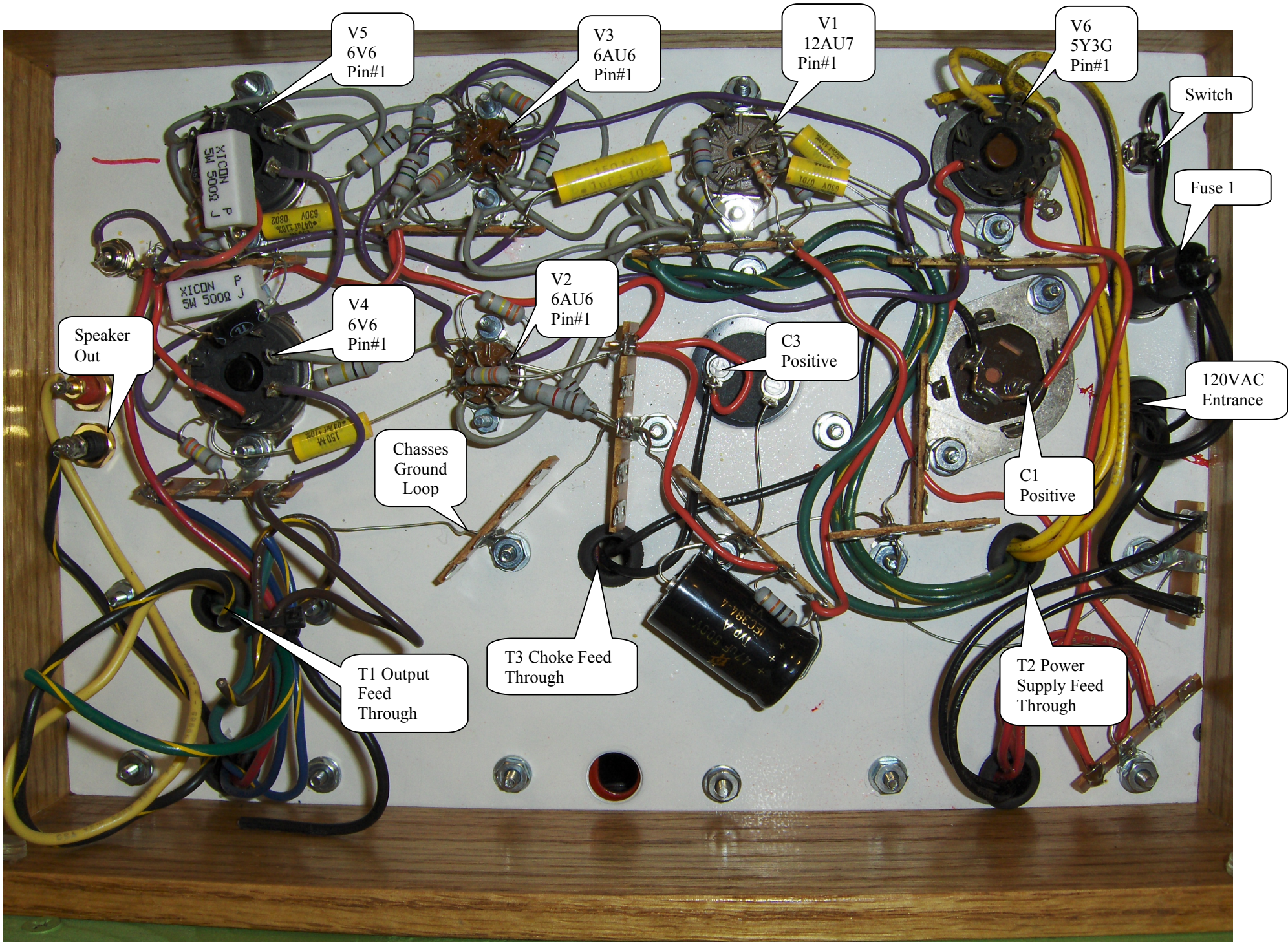

V5
6V6
Pin#1

V3
6AU6
Pin#1

V1
12AU7
Pin#1

V6
5Y3G
Pin#1

Switch

Fuse 1

120VAC
Entrance

C1
Positive

C3
Positive

V2
6AU6
Pin#1

V4
6V6
Pin#1

Chasses
Ground
Loop

Speaker
Out

T2 Power
Supply
Feed
Through

T3 Choke Feed
Through

T1 Output
Feed
Through

POWER SUPPLY SCHEMATIC

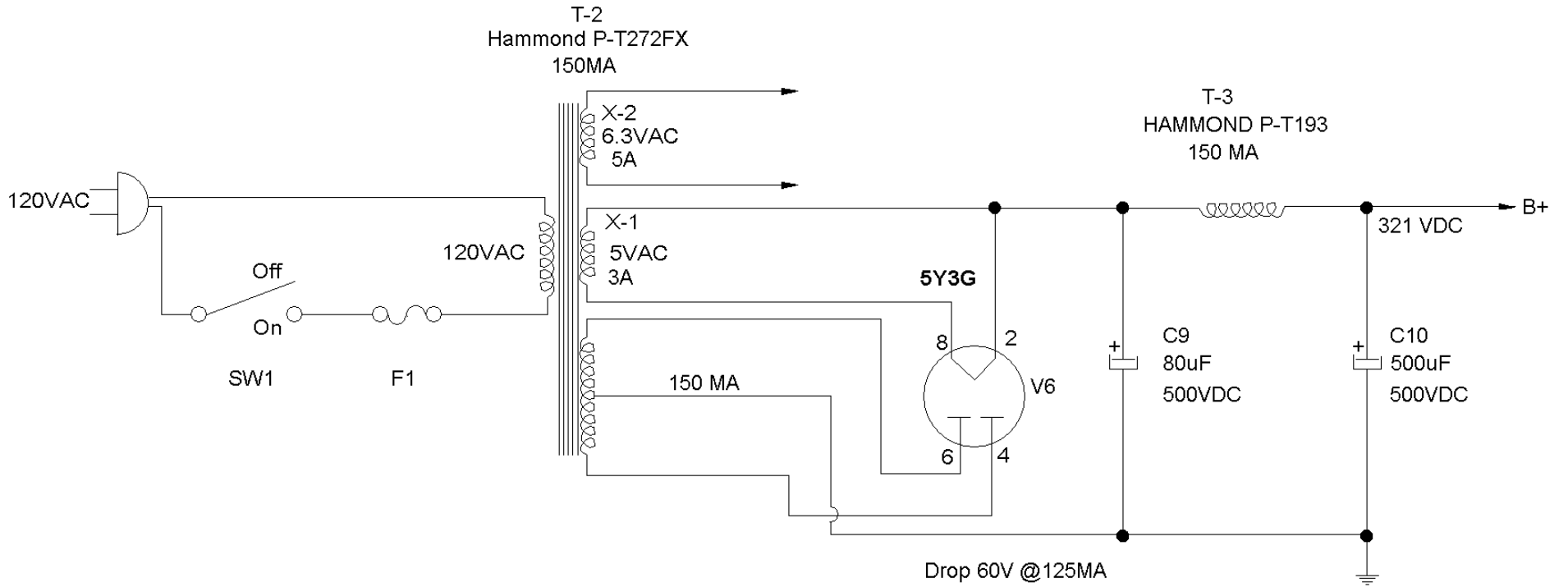

AMPLIFYER SCHEMATIC

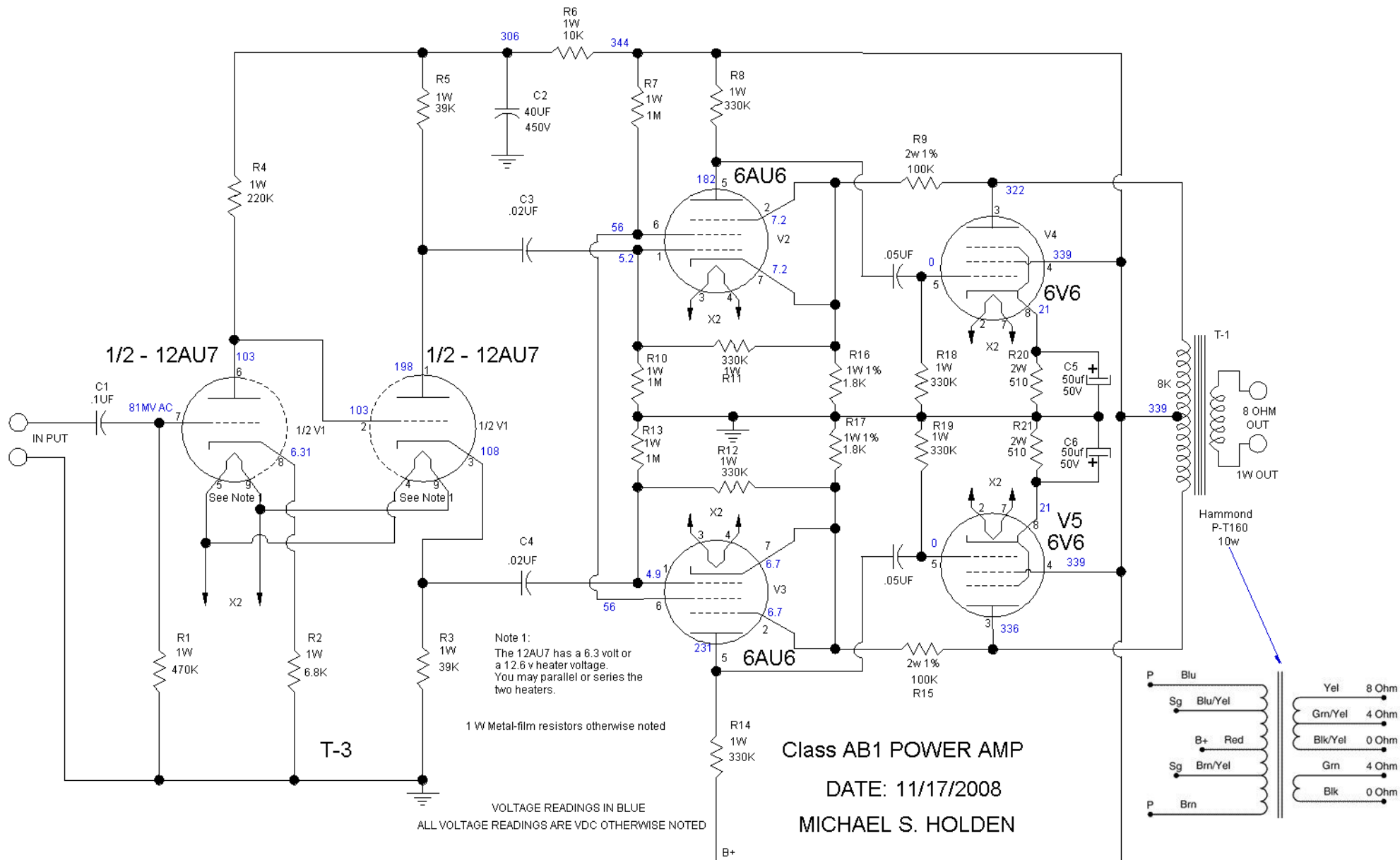

PARTS LIST

All components are brand new and purchased from Tubes and More from the internet. <https://secure.tubesandmore.com/> The parts listed uses their part number and 2009 prices. You may purchase the parts from anywhere you wish.

The amplifier schematic has been redrawn to reflect my preferences. The output transformer is a hamondP-T160 at 10W instead of the 25 watt transformer in the original schematic. The components in this circuit will never produce 25 watts and is much more expensive than the 10 watt output transformer. If you decide to replace the 6V6 tubes with 6L6 tubes this transformer as well all other circuit components would need to be reevaluated.

Quan.	Circuit Number	Tubes & More Part Number	Description		EA	TOTAL
1	C1	C-MD1-630	CAPACITOR, MALLORY 150'S, .1 iF @ 630 V	AMP	\$0.82	\$0.82
1	C2	C-ET47-500-FT	CAPACITOR, F&T AXIAL LEAD ELECTROLYTIC, 47 iF @ 500 VDC	AMP	\$4.92	\$4.92
1	C3	CA-LC-50UF-500V	F&T can capacitor, rated 50µF x 50µF / 500V	PS	\$12.00	\$12.00
2	C3, C4	C-MD022-630	CAPACITOR, MALLORY 150'S, .022 iF @ 630 V	AMP	\$0.59	\$1.18
2	C5, C6	C-ET47-50	CAPACITOR, AXIAL LEAD ELECTROLYTIC, 47 iF @ 50 VDC	AMP	\$0.62	\$1.24
2	C7, C8	C-MD047-630	CAPACITOR, MALLORY 150'S, .047 iF @ 630 V	AMP	\$0.65	\$1.30
1	R1	R-E470K	RESISTOR, METAL OXIDE POWER, 1 WATT, 470K OHM, PACKAGE OF 5	AMP	\$1.75	\$1.75
1	R2	R-E6D8K	RESISTOR, METAL OXIDE POWER, 1 WATT, 6.8K OHM, PACKAGE OF 5	AMP	\$1.75	\$1.75
1	R3, R5	R-E39K	RESISTOR, METAL OXIDE POWER, 1 WATT, 39K OHM, PACKAGE OF 5	AMP	\$1.75	\$1.75
1	R4	R-E220K	RESISTOR, METAL OXIDE POWER, 1 WATT, 220K OHM, PACKAGE OF 5	AMP	\$1.75	\$1.75
1	R6	R-E10K	RESISTOR, METAL OXIDE POWER, 1 WATT, 10K OHM, PACKAGE OF 5	AMP	\$1.75	\$1.75
1	R7, R10, R13	R-E1M	RESISTOR, METAL OXIDE POWER, 1 WATT, 1M OHM, PACKAGE OF 5	AMP	\$1.75	\$1.75
2	R8, R11, R12, R14, R18, R19	R-E330K	RESISTOR, METAL OXIDE POWER, 1 WATT, 330K OHM, PACKAGE OF 5	AMP	\$1.75	\$3.50
1	R9, R15	R-F100K	RESISTOR, METAL OXIDE POWER, 2 WATT, 100K OHM, PACKAGE OF 5	AMP	\$2.00	\$2.00
1	R16, R17	R-F1D8K	RESISTOR, METAL OXIDE POWER, 2 WATT, 1.8K OHM, PACKAGE OF 5	AMP	\$2.00	\$2.00
2	R20, R21	R-Q500	RESISTOR, WIREWOUND POWER, 5 WATT, 500 OHM RoHS Compliant	AMP	\$0.70	\$1.40
1	T1	P-T1609	TRANSFORMER, OUTPUT, PUSH-PULL, HAMMOND, 10 WATT (\$44.45)	AMP	\$44.45	\$44.45
1	T2	PT270FX	TRANSFORMER, POWER, HAMMOND, 275-0-275 V, 150 mA (\$57)	PS	\$57.00	\$57.00
1	T3	P-T193D	FILTER CHOKE, ENCLOSED, HAMMOND, 8 H, 150 mA (\$33.95)	PS	\$33.95	\$33.95
1	V1	T-12AU7A-RCA-BB	12AU7A - TRIODE, DUAL, RCA BRAND, BROWN BOX (\$28.5)	AMP	\$29.00	\$29.00
2	V2, V3	T-6AU6A_EF94	6AU6A/EF94 - PENTODE, SHARP CUTOFF	AMP	\$6.10	\$12.20
1	V4, V5		Electro-Harmonix 6V6GT SO-6V6EH (\$29.95) Price is for a matched pair	AMP	\$29.95	\$29.95
1	V6		RU-5U3C (\$19.95) Rectifier 5U4GT	PS	\$19.95	\$19.95
2		P-ST7-201MXB	SOCKET, 7 PIN, MINIATURE, MICALEX, BOTTOM MOUNT	AMP	\$0.95	\$1.90
1		P-ST9-211	SOCKET, 9 PIN, MINIATURE, BAKELITE, BOTTOM MOUNT RING	AMP	\$3.95	\$3.95
3		P-ST8-250MB	SOCKET, 8 PIN OCTAL, SADDLE PLATE, BLACK, BOTTOM MOUNT (\$2.50EA)	AMP	\$2.50	\$7.50
1			Can capacitor clamps. Diameter: 1 3/8 "CA-LC-CLAMP1 (ea \$1.95)	PS	\$1.95	\$1.95
						282.66

CHASSIS SIDES CONSTRUCTION

The chassis sides are constructed of 7/16" thick solid oak. The over all dimensions are: 12 1/4" wide by 8 1/4" deep by 2 1/2" tall. The top of the oak box is rabbit out to fit the 8" by 12" aluminum plate. The corners are 1/4" box joint fit to make a strong and attractive joint. Four coats of hand rubbed Polly Urethane protect the wood sides of the chassis.

The chassis top is a piece of 20 gauge aluminum COVER PLATE, ALUMINUM, 12" x 8", HAMMOND P-H1434-22 To control corrosion the aluminum chassis top is painted with white dry powder paint and is backed at 400 D. F. This method of painting provides a stronger surface which is more scratch resistant than normal paint.

To give the project little flair all three transformers were disassembled and red power paint was placed on the outer skins.

This dry powder paint process is quick and more durable than normal spray paint. I researched it on the web and gave it a try. I will use it again.

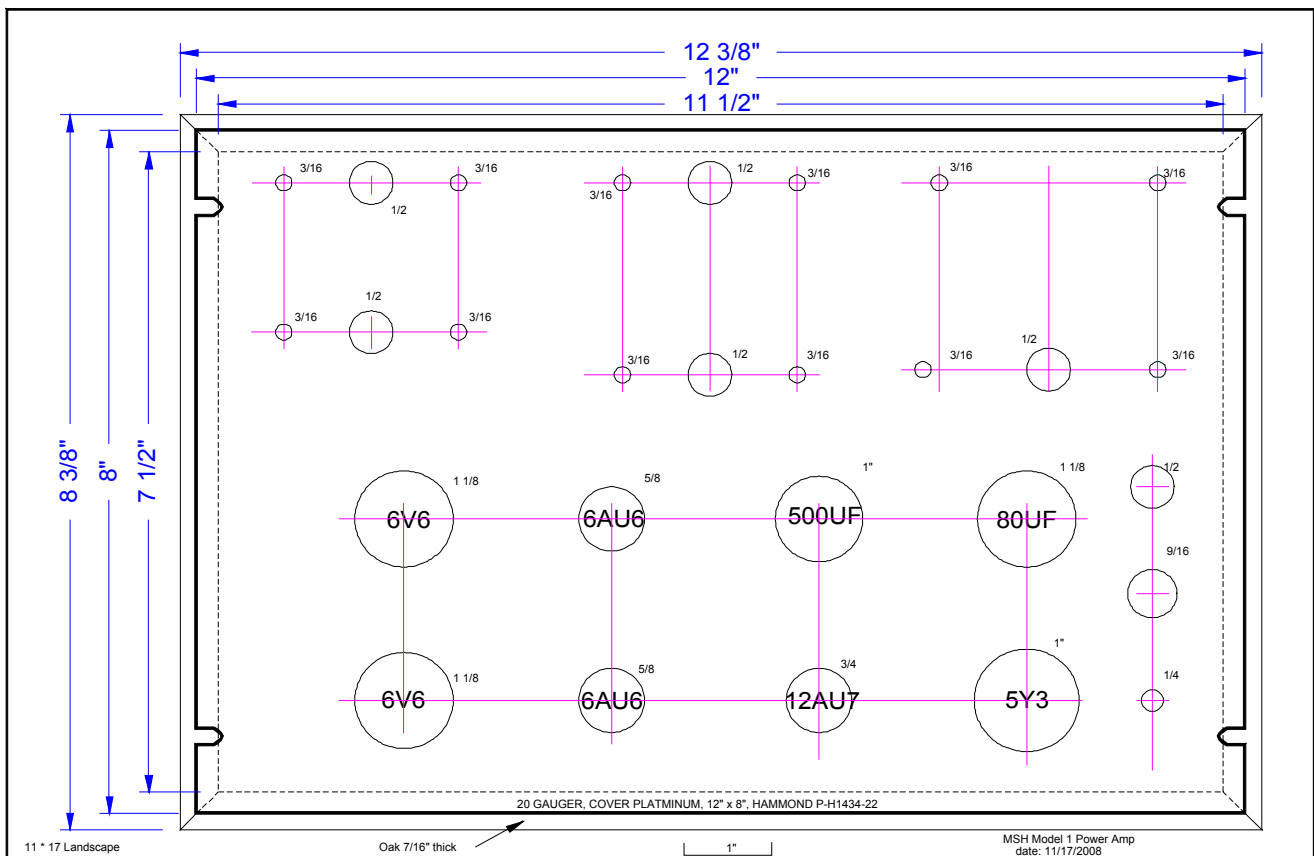

CHASSIS WIRING

The first thing to do is remove the aluminum chassis top from the chassis sides. This makes it much easier to wire. There is a ground loop which runs all around the chassis and is grounded to the chassis. Lay the components out while keeping in mind the wiring path and mechanical requirements. You will probably want to layout the components in some other format other than mine. I have shown my layout to give some ideas. I tried to balance the weight of the components and still have reasonable short wire length. The wire used was 22, 20, gage solid copper hookup wire with insulation of 600vdc.

Solder lugs were placed at different locations on the wire side of the chassis. A drill was used to start the tube sockets holes and finished of with a step drill. The hole sizes are listed on the layout sheet in the Chassis Construction chapter.

Rubber grummets 1/2" were uses any time a wire pass through the top side to the bottom side of aluminum top.

Starting and testing notes.

ECC82/12AU7

Dimensions and connections

Base: Noval

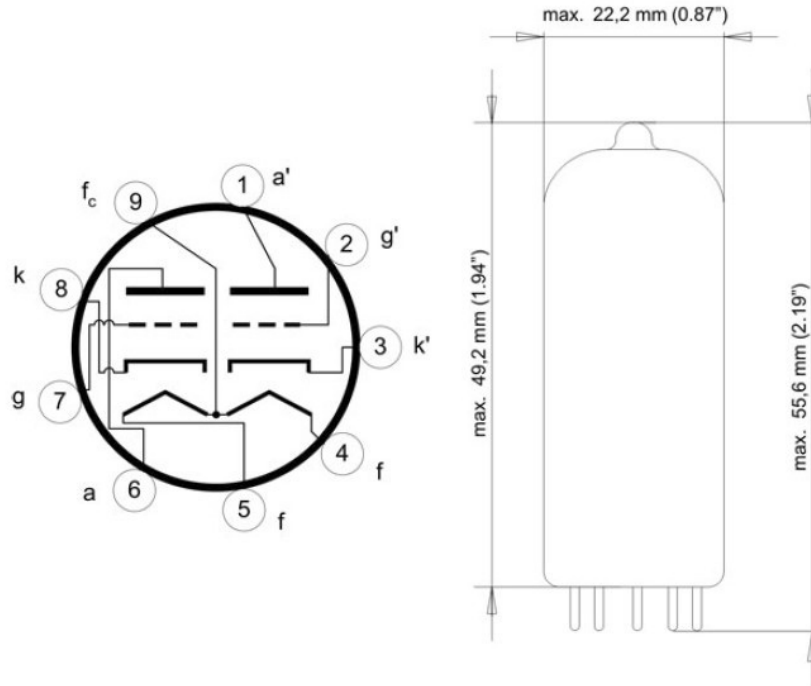

Typical characteristics and operating conditions

Anode voltage	V_a	100	250	(V)
Grid voltage	V_g	0	-8,5	(V)
Anode current	I_a	11,8	10,5	(mA)
Transconductance	S	3,1	2,2	(mA/V)
Amplification	μ	19,5	17	
Internal resistance	R_i	6,25	7,7	(k Ω)



Limiting - maximal values (design center rating system)

Anode voltage	V_{ao}	550	(V)
	V_a	300	
Anode dissipation	W_a	2.75	(W)
Cathode current	I_k	20	(mA)
Grid voltage	V_g	-100	(V)
Grid voltage, peak	V_{gp}	-250	(V)
Grid resistor (automatic bias)	R_g	1	(M Ω)
Cathode to heater voltage	V_{kf}	180	(V)
Cathode to heater circuit resistance in phase splitting circuits	R_{kf}	150	(k Ω)

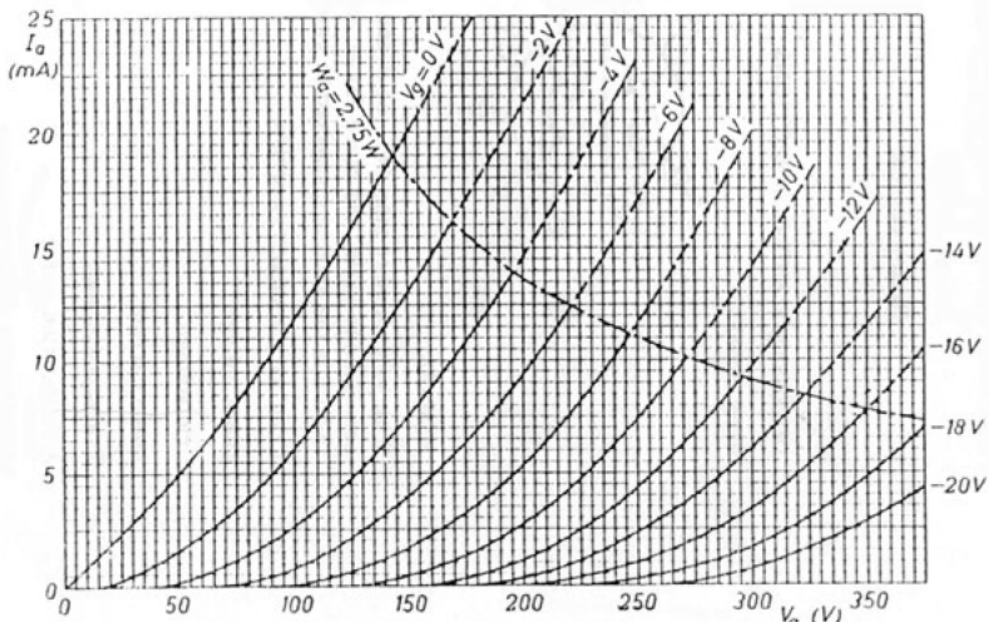

**5Y3GT
Full-Wave Rectifier**

Base & Bulb (RCA RC-15 - 1947)

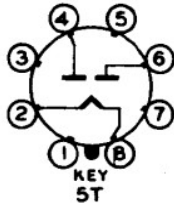

EIA Bulb 9-13 9-42

Application

Glass octal type used in power supply of radio equipment having moderate dc requirements. Requires octal socket. Vertical tube mounting is preferred, but horizontal operation is permissible if pins 2 and 8 are in horizontal plane.

Mechanical Data

Bulb T-9
 Base Intermediate Octal 6-Pin
 Outline 9-13 9-42
 EIA Base 5T
 Mounting Position Any

Electrical Data

Heater Voltage 5.0 V
 Heater Current 2.0 A

Maximum Ratings (Design Center Values)

Each Diode

Peak Inverse Plate Voltage 1400 V
 Voltage Drop @ Current 50 V @ 125 mA

Characteristics and Typical Operation

Rectifier

AC Plate Supply Voltage Each Plate (RMS) 350 V
 Input Capacitor 20 Mfd
 Effective Plate Supply Impedance Each Plate ... 50 Ω
 DC Half-Load Output Current 62.5 mA
 DC Half-Load Output Voltage 390 V
 DC Output Current 125 mA
 DC Output Voltage 360 V
 Voltage Regulation (Half-Load to Full-Load) ... 40 V

Characteristics and Typical Operation

Rectifier

AC Plate Supply Voltage Each Plate (RMS) 500 V
 Input Capacitor 10 Mfd
 Effective Plate Supply Impedance Each Plate ... 140 Ω
 DC Half-Load Output Current 42 mA
 DC Half-Load Output Voltage 610 V
 DC Output Current 84 mA
 DC Output Voltage 560 V
 Voltage Regulation (Half-Load to Full-Load) ... 50 V

Characteristics and Typical Operation

Rectifier

AC Plate Supply Voltage Each Plate (RMS) 350 V
 Input Inductor 10 H
 DC Half-Load Output Current 75 mA
 DC Half-Load Output Voltage 270 V
 DC Output Current 150 mA
 DC Output Voltage 245 V
 Voltage Regulation (Half-Load to Full-Load) ... 25 V

Characteristics and Typical Operation

Rectifier

AC Plate Supply Voltage Each Plate (RMS) 500 V
 Input Inductor 10 H
 DC Half-Load Output Current 62.5 mA
 DC Half-Load Output Voltage 405 V
 DC Output Current 125 mA
 DC Output Voltage 380 V
 Voltage Regulation (Half-Load to Full-Load) ... 15 V

6V6



6V6-GT—5V6-GT

BEAM PENTODE

6V6-GT
5V6-GT
 ET-T914
 Page 1
 3-55

DESCRIPTION AND RATING

The 6V6-GT is a beam-power pentode designed for use in the audio-frequency power output stage of television and radio receivers. In this application, it is capable of supplying high power output with high sensitivity, high efficiency, and low third and higher-order harmonic distortion. The 6V6-GT may also be used as a triode-connected vertical-deflection amplifier in television receivers.

Except for heater ratings, the 5V6-GT is identical to the 6V6-GT. In addition, the 5V6-GT, as a result of its controlled heater warm-up characteristic, is especially suited for use in television receivers which employ series-connected heaters. When the 5V6-GT is used in conjunction with other 600-milliamper types which exhibit essentially the same heater warm-up characteristic, heater voltage surges across the individual tubes are minimized during the warm-up period.

GENERAL

ELECTRICAL

Cathode—Coated Unipotential	5V6-GT	6V6-GT
Heater Voltage, AC or DC	4.7	6.3 Volts
Heater Current	0.6	0.45 Amperes
Heater Warm-up Time*	11	— Seconds
Direct Interelectrode Capacitances, approximate†		
Grid-Number 1 to Plate	0.7	μμf
Input	9.0	μμf
Output	7.5	μμf

MECHANICAL

Mounting Position—Any
 Envelope—T-9, Glass
 Base—B6-81 or B7-7, Intermediate Shell Octal
 or B6-84 or B7-59, Short Intermediate Shell Octal

MAXIMUM RATINGS

DESIGN-CENTER VALUES UNLESS OTHERWISE INDICATED

	Class A ₁ Amplifier	Vertical-Deflection Amplifier‡ (Triode Connection) π
DC Plate Voltage	315	315 Volts
Peak Positive Pulse Plate Voltage	—	1200▲ Volts
Screen-Supply Voltage	315	— Volts
Screen Voltage	285	— Volts
Peak Negative Grid-Number 1 Voltage	—	250 Volts
Plate Dissipation†	12	9.0 Watts
Screen Dissipation	2.0	— Watts
DC Cathode Current	—	35 Milliamperes
Peak Cathode Current	—	105 Milliamperes
Heater-Cathode Voltage		
Heater Positive with Respect to Cathode		
DC Component	100	100 Volts
Total DC and Peak	200	200 Volts
Heater Negative with Respect to Cathode		
Total DC and Peak	200	200 Volts
Grid-Number 1 Circuit Resistance		
With Fixed Bias	0.1	— Megohms
With Cathode Bias	0.5	2.2 Megohms

BASING DIAGRAM

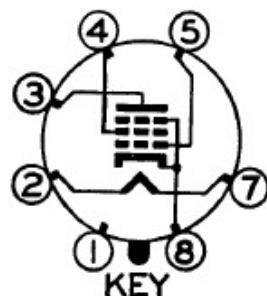

RETMA 7AC

TERMINAL CONNECTIONS

Pin 1—No Connection‡
 Pin 2—Heater
 Pin 3—Plate
 Pin 4—Grid Number 2
 (Screen)
 Pin 5—Grid Number 1
 Pin 7—Heater
 Pin 8—Cathode and Beam
 Plates

‡ Pin 1 omitted on bases B6-81 and B6-84.

PHYSICAL DIMENSIONS

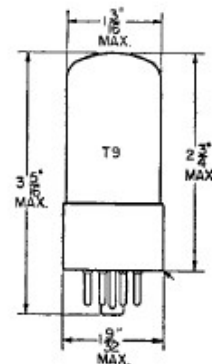
RETMA 9-11
or 9-41

GENERAL ELECTRIC

Supersedes ET-T351D, dated 6-53

CHARACTERISTICS AND TYPICAL OPERATION

CLASS A₁ AMPLIFIER

Plate Voltage	180	250	315	Volts
Screen Voltage	180	250	225	Volts
Grid-Number 1 Voltage	-8.5	-12.5	-13.0	Volts
Peak AF Grid-Number 1 Voltage	8.5	12.5	13.0	Volts
Plate Resistance, approximate	50000	50000	80000	Ohms
Transconductance	3700	4100	3750	Micromhos
Zero-Signal Plate Current	29	45	34	Milliamperes
Maximum-Signal Plate Current	30	47	35	Milliamperes
Zero-Signal Screen Current	3.0	4.5	2.2	Milliamperes
Maximum-Signal Screen Current	4.0	7.0	6.0	Milliamperes
Load Resistance	5500	5000	8500	Ohms
Total Harmonic Distortion, approximate	8	8	12	Percent
Maximum-Signal Power Output	2.0	4.5	5.5	Watts

PUSH-PULL CLASS AB₁ AMPLIFIER, VALUES FOR TWO TUBES

Plate Voltage	250	285	Volts
Screen Voltage	250	285	Volts
Grid-Number 1 Voltage	-15	-19	Volts
Peak AF Grid-to-Grid Voltage	30	38	Volts
Zero-Signal Plate Current	70	70	Milliamperes
Maximum-Signal Plate Current	79	92	Milliamperes
Zero-Signal Screen Current	5.0	4.0	Milliamperes
Maximum-Signal Screen Current	13	13.5	Milliamperes
Effective Load Resistance, Plate-to-Plate	10000	8000	Ohms
Total Harmonic Distortion	5	3.5	Percent
Maximum-Signal Power Output	10	14	Watts

AVERAGE CHARACTERISTICS, TRIODE CONNECTION π

Plate Voltage	250	Volts
Grid-Number 1 Voltage	-12.5	Volts
Amplification Factor	9.8	
Plate Resistance, approximate	1960	Ohms
Transconductance	5000	Micromhos
Plate Current	49.5	Milliamperes
Grid-Number 1 Voltage, approximate $I_b = 0.5$ Milliampere	-36	Volts

* Heater warm-up time is defined as the time required in the circuit shown at the right for the voltage across the heater terminals to increase from zero to the heater test voltage (V_1). For this type, $E = 18.7$ volts (RMS or DC), $V_1 = 3.73$ volts (RMS or DC), and $R = 23.5$ ohms.

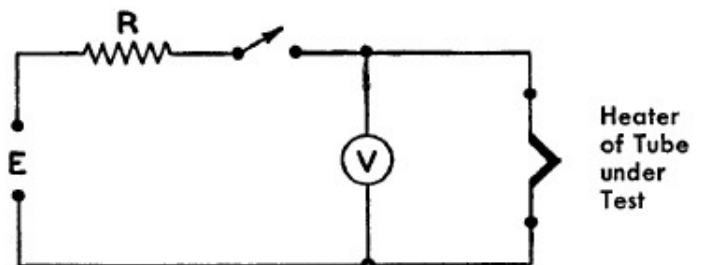

† Without external shield.

§ For operation in a 525-line, 30-frame television system as described in "Standards of Good Engineering Practice Concerning Television Broadcast Stations," Federal Communications Commission. The duty cycle of the voltage pulse must not exceed 15 percent of one scanning cycle.

π With screen connected to plate.

▲ Value given is to be considered as an Absolute Maximum Rating. In this case, the combined effect of supply voltage variation, manufacturing variation including components in the equipment, and adjustment of equipment controls should not cause the rated value to be exceeded.

◆ In stages operating with grid-leak bias, an adequate cathode-bias resistor or other suitable means is required to protect the tube in the absence of excitation.

TUNG-SOL

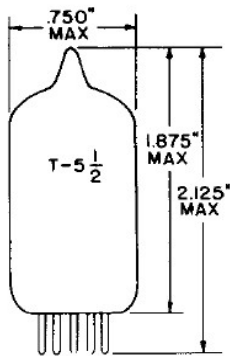

GLASS BULB
MINIATURE BUTTON
7 PIN BASE E7-1
OUTLINE DRAWING
JEDEC 5-2

PENTODE

MINIATURE TYPE

COATED UNIPOTENTIAL CATHODE

HEATER

6.3 ± 0.6 VOLTS 300 MA.

AC OR DC

ANY MOUNTING POSITION

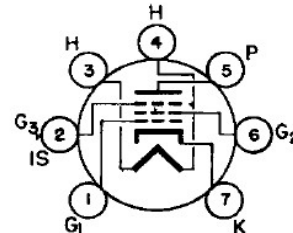

BOTTOM VIEW
BASING DIAGRAM
JEDEC 7BK

THE 6AU6 AND 6AU6A ARE PENTODE AMPLIFIERS HAVING A SHARP CUTOFF CONTROL CHARACTERISTIC. WITH HIGH TRANSCONDUCTANCE AND LOW GRID TO PLATE CAPACITANCE THEY ARE INTENDED FOR SERVICE AS EITHER RF OR AF AMPLIFIERS. IN ADDITION, THERMAL CHARACTERISTICS OF THE HEATER OF THE 6AU6A ARE CONTROLLED SUCH THAT HEATER VOLTAGE SURGES DURING THE WARM-UP CYCLE ARE MINIMIZED PROVIDED IT IS USED WITH OTHER TYPES WHICH ARE SIMILARLY CONTROLLED. EXCEPT FOR THE CONTROLLED HEATER WARM-UP TIME AND HIGHER HEATER-CATHODE VOLTAGE RATINGS OF THE 6AU6A, THE TWO TUBES ARE IDENTICAL.

DIRECT INTERELECTRODE CAPACITANCES

	WITH SHIELD ^A	WITHOUT SHIELD	
PENTODE CONNECTION:			
GRID TO PLATE: (G ₁ TO P) MAX.	0.003	0.003	pf
INPUT: G ₁ TO (H+K+G ₂ +G ₃ &IS)	5.5	5.5	pf
OUTPUT: P TO (H+K+G ₂ +G ₃ &IS)	5	5	pf
TRIODE CONNECTION:			
GRID TO PLATE: G ₁ TO (P+G ₂ +G ₃ &IS)	2.6	2.6	pf
INPUT: G ₁ TO (H+K)	3.2	3.2	pf
OUTPUT: (P+G ₂ +G ₃ &IS) TO (H+K)	8.5	1.2	pf

^A SHIELD #316 CONNECTED TO PIN #7.

→ **MAXIMUM RATINGS**
DESIGN MAXIMUM VALUES - SEE EIA STANDARD RS-239

TRIODE CONNECTION^C PENTODE CONNECTION

	TRIODE CONNECTION ^C	PENTODE CONNECTION	
MAXIMUM HEATER-CATHODE VOLTAGE:			
HEATER NEGATIVE WITH RESPECT TO CATHODE	200	200	VOLTS
HEATER POSITIVE WITH RESPECT TO CATHODE	200*	200*	VOLTS
MAXIMUM PLATE VOLTAGE	275	330	VOLTS
MAXIMUM GRID #2 SUPPLY VOLTAGE	---	330	VOLTS
MAXIMUM GRID #2 VOLTAGE	---	SEE J5-C4-2	
MAXIMUM GRID #3 VOLTAGE PIN #2 CONNECTED TO:	PLATE	CATHODE	
MAXIMUM PLATE DISSIPATION	3.5	3.5	WATTS
MAXIMUM GRID #2 DISSIPATION	---	---	WATTS
MAXIMUM GRID #2 INPUT:*			VOLTS
FOR GRID #2 VOLTAGES UP TO 165 VOLTS	---	0.75	WATT
FOR GRID #2 VOLTAGES BETWEEN 165 VOLTS AND 330 VOLTS *	---	SEE J5-C4-2	
MAXIMUM POSITIVE DC GRID #1 VOLTAGE	0	0	VOLTS
HEATER WARM-UP TIME (APPROX.) * (6AU6A ONLY)		11.0	SECONDS

→ INDICATES A CHANGE.

TUNG-SOL

CONTINUED FROM PRECEDING PAGE

TYPICAL OPERATING CONDITIONS AND CHARACTERISTICS

CLASS A₁ AMPLIFIER - PENTODE CONNECTION

PLATE VOLTAGE	100	250	250	VOLTS
GRID #2 VOLTAGE	100	125	130	VOLTS
CATHODE BIAS RESISTOR	150	100	68	OHMS
GRID #3 VOLTAGE	PIN #2 CONNECTED TO PIN #7 AT SOCKET			
TRANSCONDUCTANCE	3 900	4 500	5 200	μMHOS
PLATE CURRENT	5	7.6	10.6	MA.
GRID #2 CURRENT	2.1	3	4.3	MA.
PLATE RESISTANCE (APPROX.)	0.5	1.5	1	MEGOHMS
GRID #1 VOLTAGE (APPROX.) FOR $I_b = 10 \mu A$.	-4.2	-5.5	-6.5	VOLTS

CLASS A₁ AMPLIFIER - TRIODE CONNECTION^C

PLATE VOLTAGE	250	VOLTS
GRID #2 VOLTAGE	PLATE	
CATHODE RESISTOR	330	OHMS
GRID #3 VOLTAGE	PLATE	
TRANSCONDUCTANCE	4 800	μMHOS
PLATE CURRENT	12.2	MA.
AMPLIFICATION FACTOR	36	

^C TRIODE CONNECTION: GRID #2 AND GRID #3 CONNECTED TO PLATE.

* HEATER WARM-UP TIME IS DEFINED AS THE TIME REQUIRED FOR THE VOLTAGE ACROSS THE HEATER TO REACH 80% OF ITS RATED VOLTAGE AFTER APPLYING 4 TIMES RATED HEATER VOLTAGE TO A CIRCUIT CONSISTING OF THE TUBE HEATER IN SERIES WITH A RESISTANCE OF VALUE 3 TIMES THE NOMINAL HEATER OPERATING RESISTANCE.

THE DC COMPONENT MUST NOT EXCEED 100 VOLTS.

AUDIO SPECIFICATIONS

Power Output

Just Before Ringing Starts 8.46 Watts

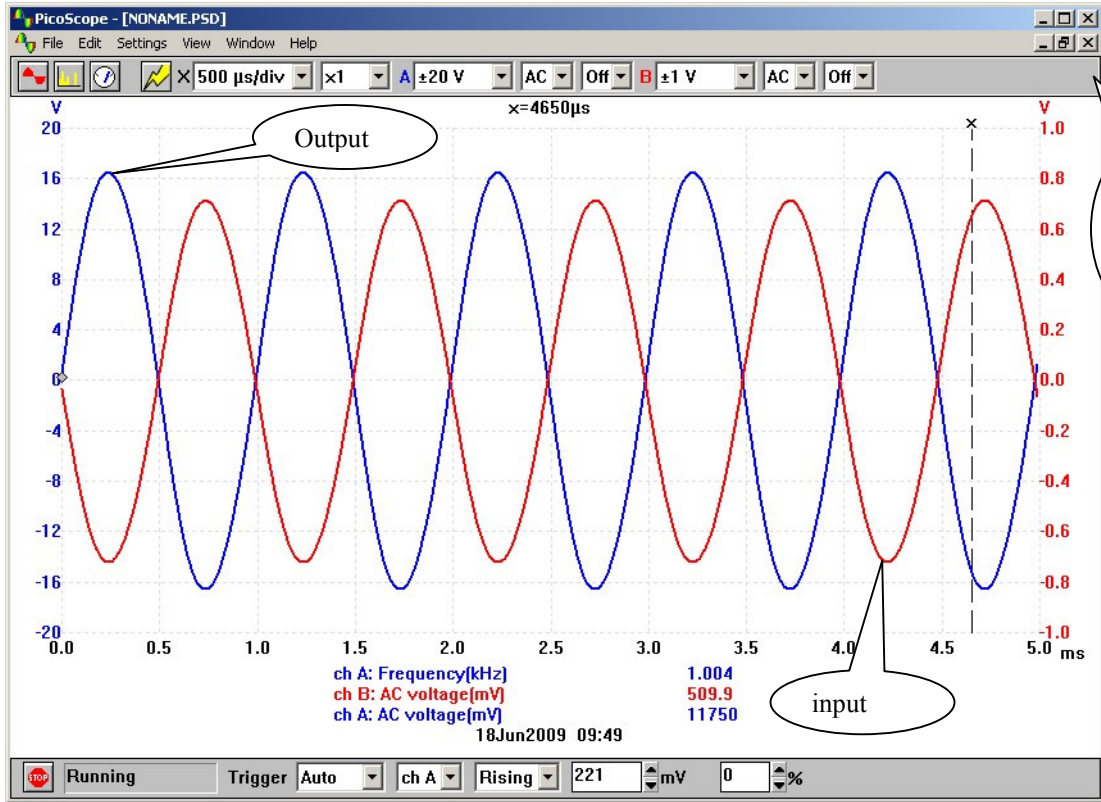

Max Output 13.73 Watts

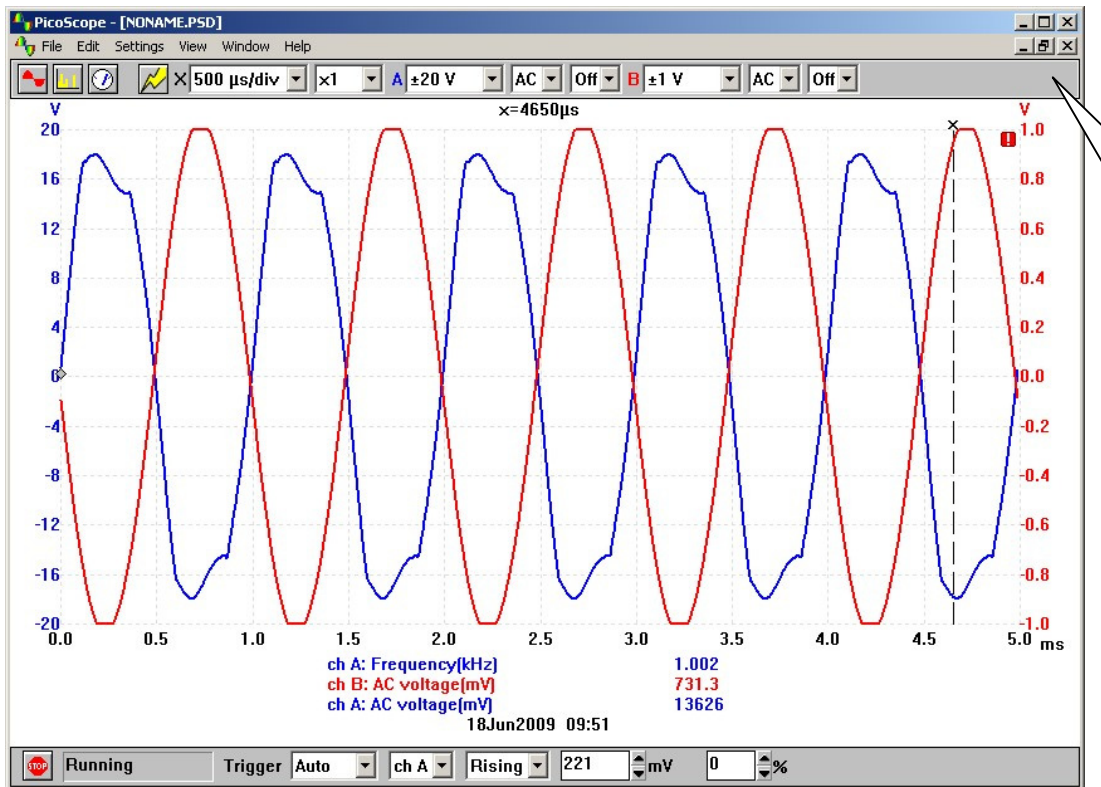

All of the max specifications will come from the just before ringing data. This will insure that the specifications were not set with the Max output data. The specification numbers will be less but more respective of legible listing levels.

Max Input Level 509 MV

Input Impedance

Output Impedance: 8 Ohm

Maximum Gain is: 23

THD+N Total Harmonic Distortion + Noise

Band Width (Frequency Response) 30hz to 20khz,

	dBu
20Hz	15.635107
30Hz	17.086121
40Hz	17.180363
50Hz	17.336376
60Hz	17.483836
70Hz	17.742214
80Hz	17.8985
90Hz	17.715138
100Hz	17.570436
200Hz	17.200768
300Hz	17.20676
400Hz	17.25217
500Hz	17.30208
600Hz	17.34346
700Hz	17.38346
800Hz	17.41744
900Hz	17.44429
1kHz	17.47339
2kHz	17.52782
3kHz	17.59911
4kHz	17.63112
5kHz	17.63796
6kHz	17.62198
7kHz	17.59797
8kHz	17.57618
9kHz	17.55318
10kHz	17.48384
20kHz	17.0691

Input Voltage was 1 volt P/P

Reference voltage V0 = 1 Volt = 0 dBV

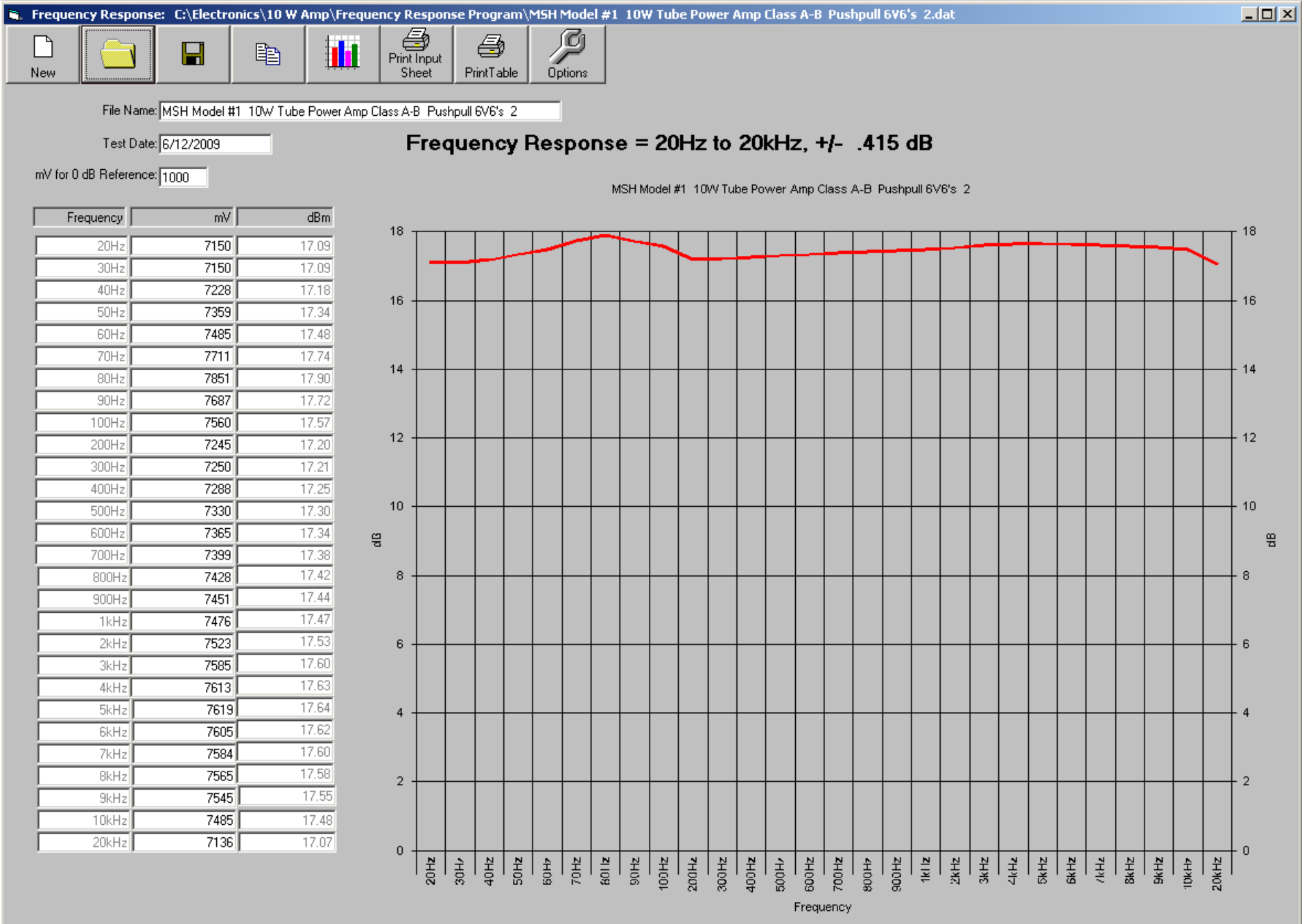

The frequency response chart was created using a small VB program I created. If any one wants a copy please email me at MS.Holden@comcast.net and I will email you a copy of the program. The amp seems to suffer performance below 30hz. This depends on the level of the input voltage so I picked an arbitrary level.

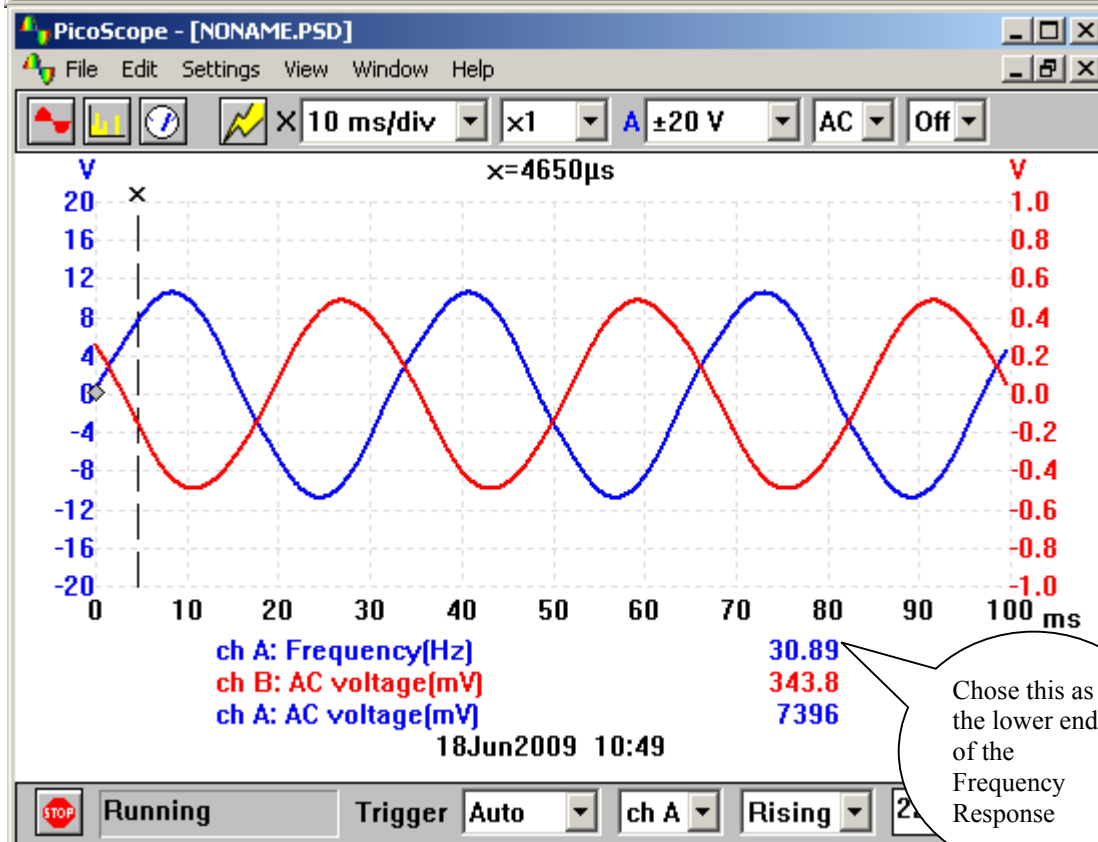
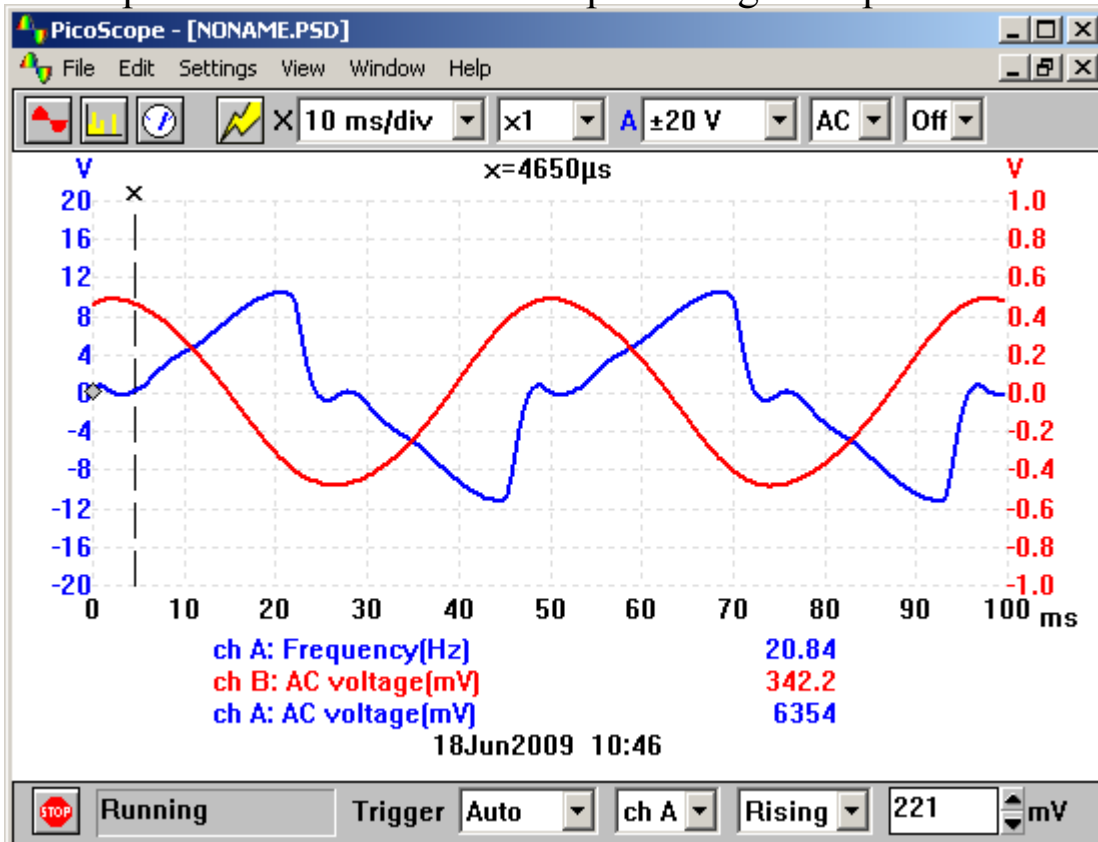

TOOLS USED FOR THIS PROJECT

Here is a drilling template. A one inch scale is displayed on the bottom of the document. The PDF document will be laid out to print landscape on 11 by 17 inch paper and the template will be full scale.

I used a step drill to drill the larger holes in the aluminum chassis top. If you do not have one of these bits you may want to get one. They are a real time saver.

Another time saver is a nibbler. I use a nibbler almost every time I do aluminum chassis work.

I used this PC oscilloscope to analyze and determine the Amp performance listed in the specifications. The software which comes with this scope also has a Spectrum Analyzer.

The audio generator was used is to develop the frequency response of the amp.

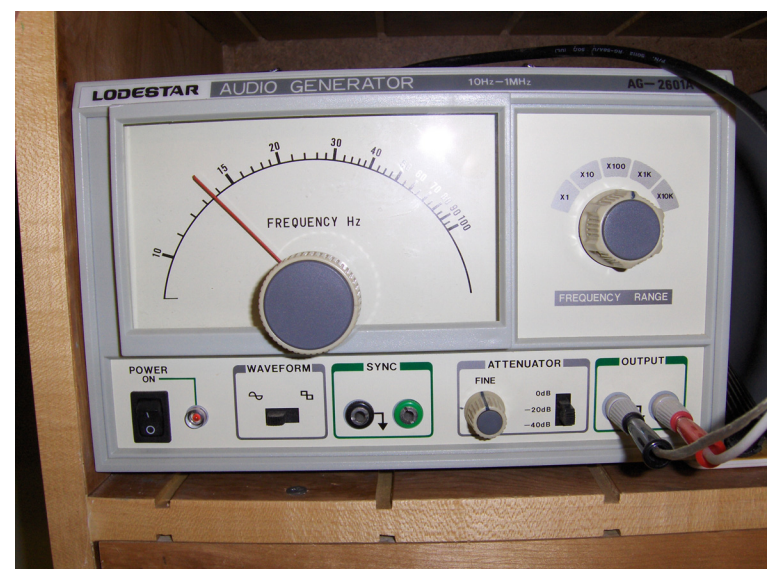
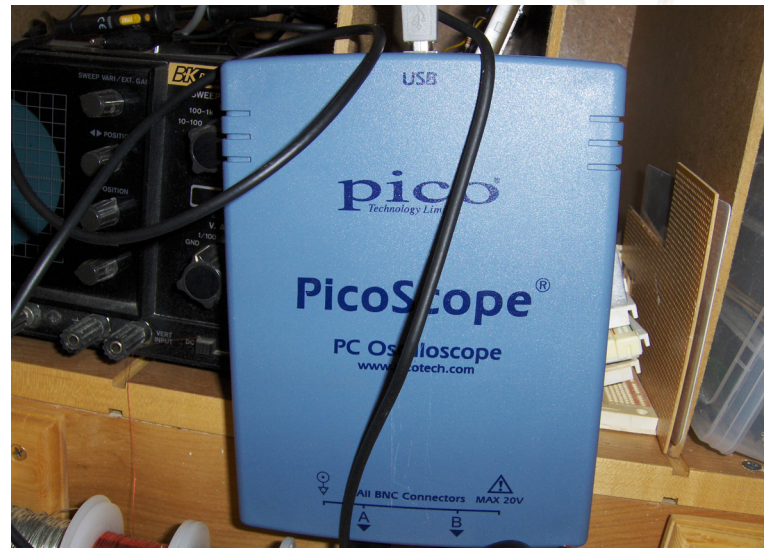

CONCLUSION

I am sure that there are better tube power amps out there. This one works fine for me. A 10W tube amp with a high SPL speaker of 90 dB or better is a good combination and delivers the sound that I heard when I was a boy.



This is the preamplifier I built to go with the Model-1 Power Amp.

ABOUT ME

I was borne in Urbana, Illinois in 1950. I have a great deal of interests in many different fields. I started off with electronics some where around 1963. Learned to repairing tube TV and tube radios. I wish that I would have kept all of the tubes I use to have but I didn't, got rid of them in 1970 when I was drafted. During High School I worked part time at a bicycle shop as a bike mechanic. Also at that time I got into auto mechanics and built two 1957 Chevy. Tore the small block engine all the way down and put back together. I had fun and learned quite a bit.

After the Army I became a self employed bricklayer for 6 years. Learned a lot about the home construction. My dad passes wood working skills on to me. Built several pieces of furniture. This is one of my skills that I do today for fun.

In 1977 through 2006 I learned flow measuring skills and be came an instrumentation technician and later supervised instrumentation technician. At the same time I was exposed to 3 phase industrial electricity. I learned the ins and outs and eventually supervised 5 plant electricians. During this period I worked with computers to the point of driving me crazy. I retired work in 2006 and started diving deep in some of my interest.

Building tube amps and solid state amps. Built a CNC machine from the ground up and use it for wood working and milling PCB. I know several other fields of discipline but tired of talking about my self.

I some times think about manipulating inanimate objects over distances at the speed of light. Not sure I can trust those silly cone diodes (Ware Games) with my atoms.

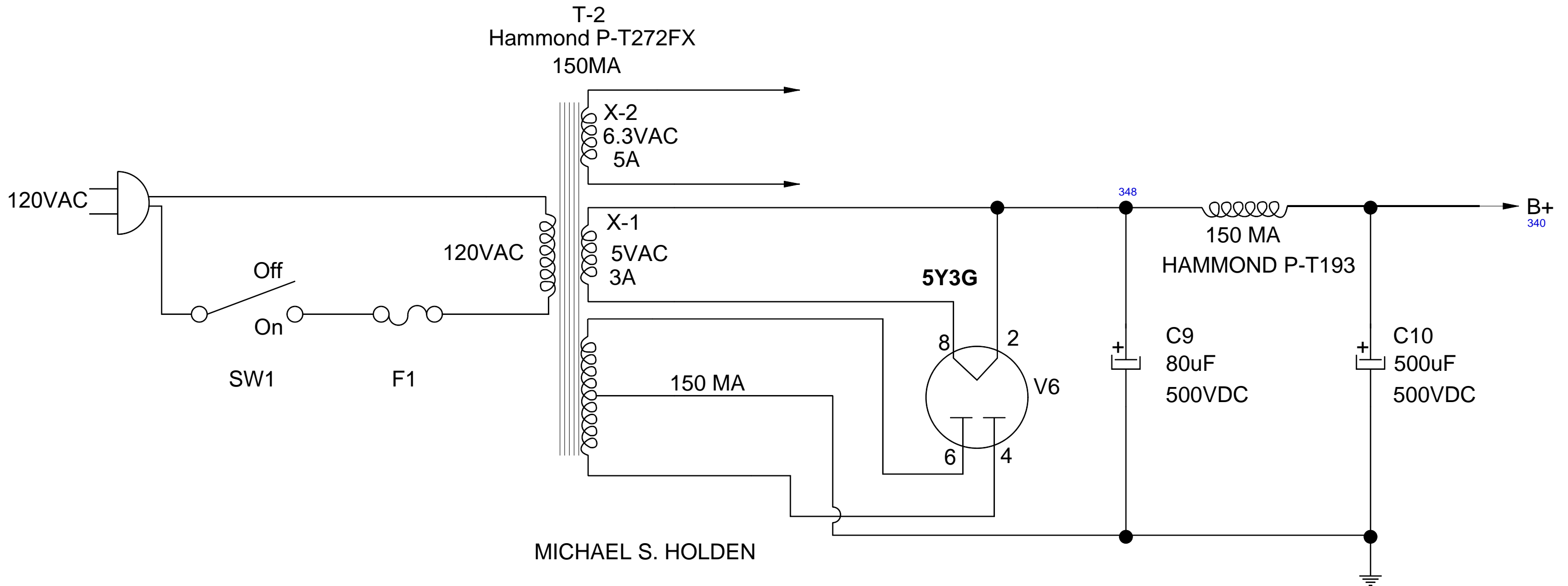

12 3/8"
12"
11 1/2"

8 3/8"
8"
7 1/2"

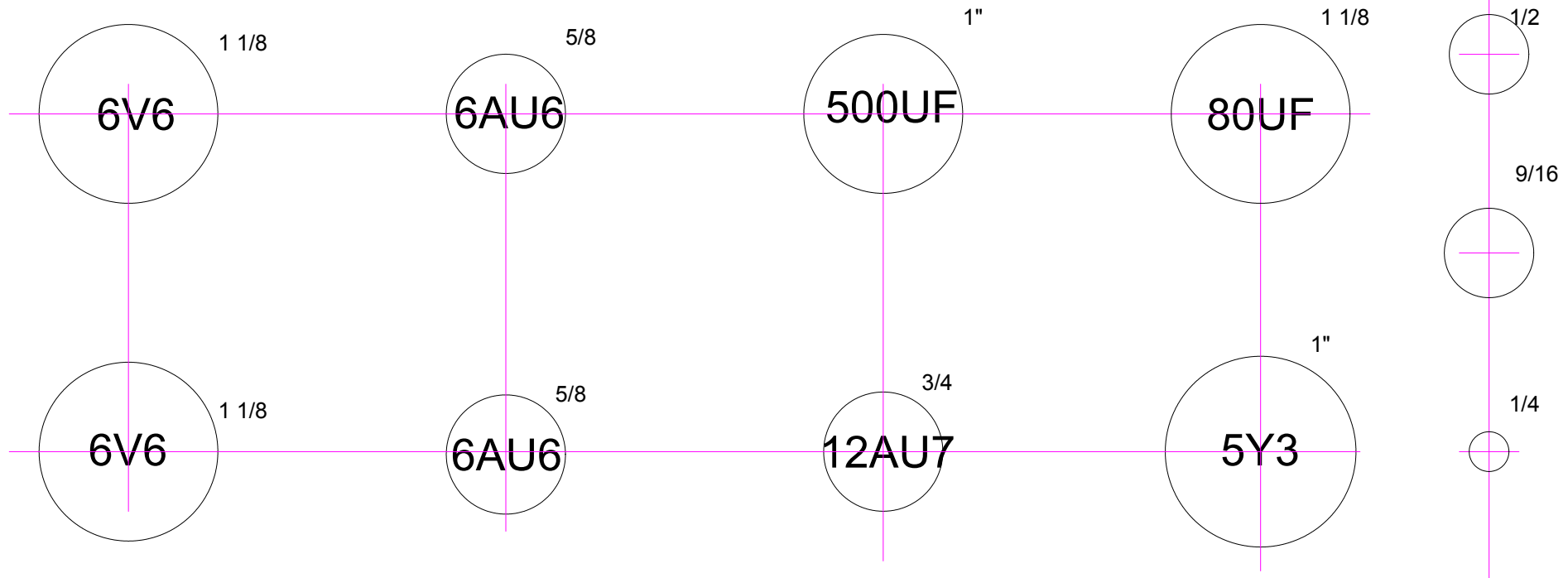
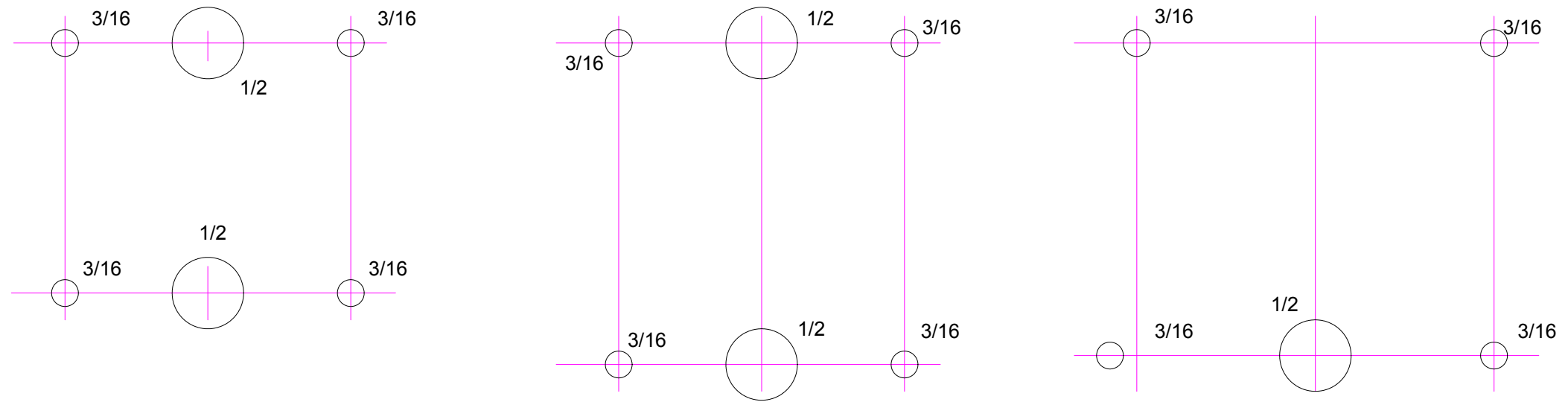

20 GAUGER, COVER PLATMINUM, 12" x 8", HAMMOND P-H1434-22

11 * 17 Landscape

Oak 7/16" thick

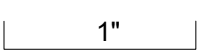

MSH Model 1 Power Amp
date: 11/17/2008

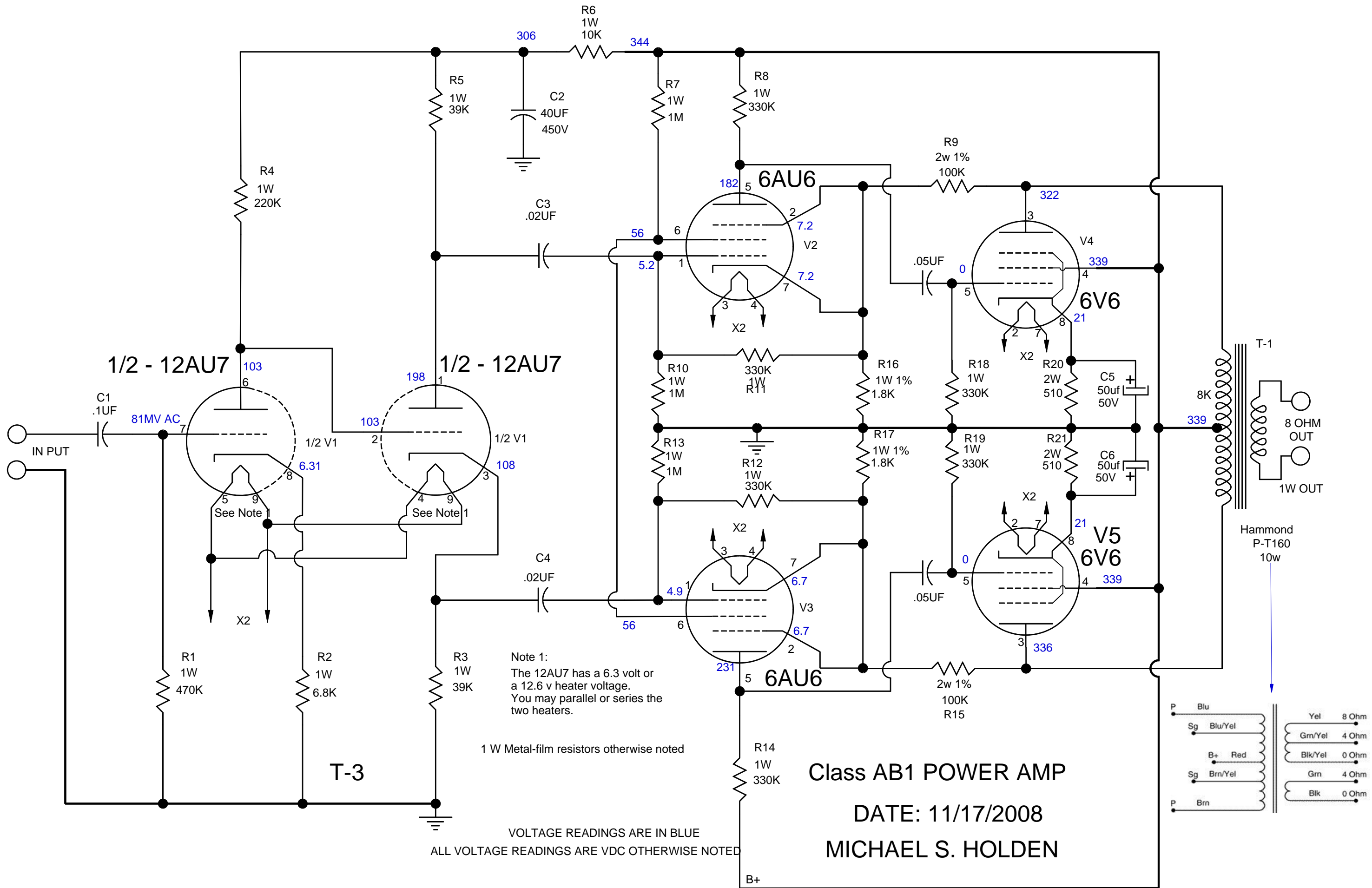

1/2 - 12AU7

1/2 - 12AU7

6AU6

6V6

6AU6

6V6

Note 1:
The 12AU7 has a 6.3 volt or a 12.6 v heater voltage. You may parallel or series the two heaters.

1 W Metal-film resistors otherwise noted

Class AB1 POWER AMP

DATE: 11/17/2008

MICHAEL S. HOLDEN

VOLTAGE READINGS ARE IN BLUE
ALL VOLTAGE READINGS ARE VDC OTHERWISE NOTED

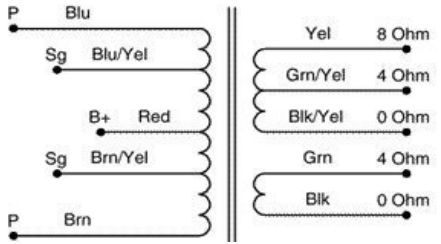

Hammond P-T160 10w

8K

8 OHM OUT

1W OUT

T-1

T-3

IN PUT

B+

C1 .1UF

81MV AC

103

6.31

1/2 V1

2

103

198

1/2 V1

3

108

See Note 1

See Note 1

X2

X2

X2

X2

X2

X2

X2

X2

X2

X2

X2

X2

X2

X2

X2

X2

X2

X2

X2

X2

X2

X2

X2

X2

X2

X2

X2

X2

X2

X2

X2

X2