

Steel music wire, diameter = 0.032"
 All bends are 90 degrees

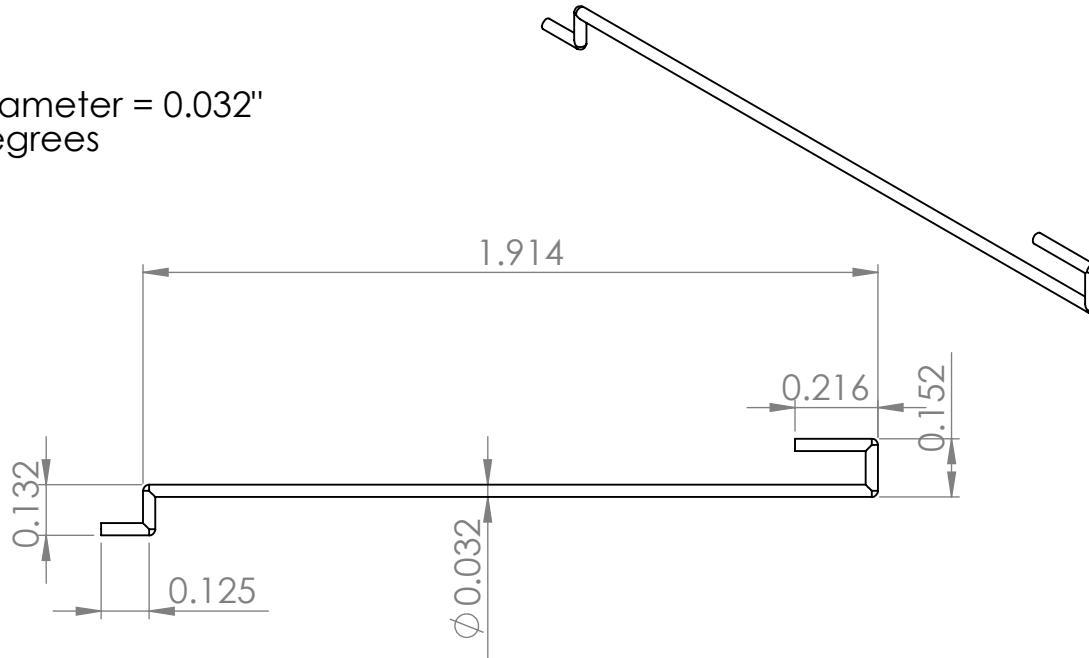

PROPRIETARY AND CONFIDENTIAL
 THE INFORMATION CONTAINED IN THIS
 DRAWING IS THE SOLE PROPERTY OF
 XYZbot LLC. ANY
 REPRODUCTION IN PART OR AS A WHOLE
 WITHOUT THE WRITTEN PERMISSION OF
 XYZbot LLC IS PROHIBITED.

		UNLESS OTHERWISE SPECIFIED:		NAME	DATE		
		DIMENSIONS ARE IN INCHES TOLERANCES: 0.005		DRAWN	kll	4/30/13	TITLE: control wire, horizontal
		FRACTIONAL ±		CHECKED			
		ANGULAR: MACH ± BEND ±		ENG APPR.			
		TWO PLACE DECIMAL ±		MFG APPR.			
		THREE PLACE DECIMAL ±		Q.A.			
		INTERPRET GEOMETRIC TOLERANCING PER:		COMMENTS:			
		MATERIAL; music wire, .032" diameter					SIZE DWG. NO. REV
		FINISH					A 12060 B
NEXT ASSY	USED ON						SCALE: 1:1 WEIGHT: SHEET 1 OF 1
APPLICATION		DO NOT SCALE DRAWING					