

Material: steel music wire, diameter = 0.032"

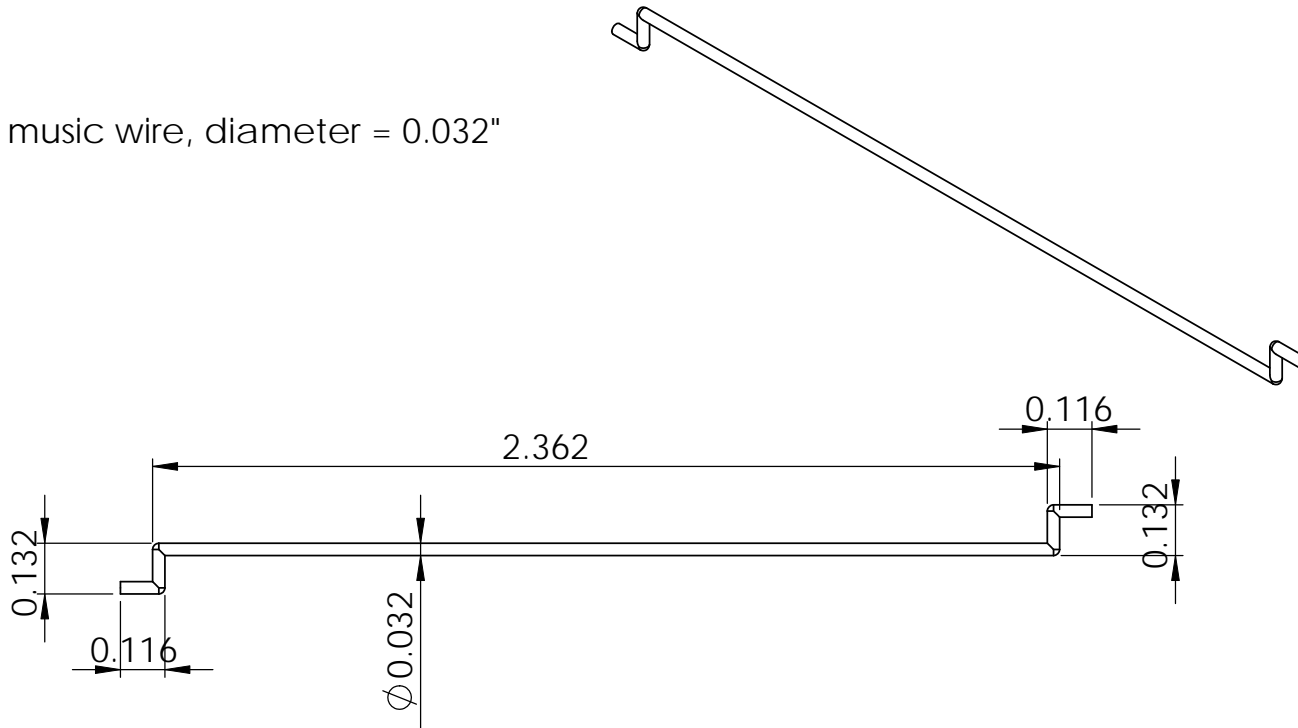

PROPRIETARY AND CONFIDENTIAL
 THE INFORMATION CONTAINED IN THIS DRAWING IS THE SOLE PROPERTY OF XYZbot LLC. ANY REPRODUCTION IN PART OR AS A WHOLE WITHOUT THE WRITTEN PERMISSION OF XYZbot LLC IS PROHIBITED.

		UNLESS OTHERWISE SPECIFIED:		NAME	DATE				
		DIMENSIONS ARE IN INCHES	DRAWN	kil	4/30/13	TITLE: control wire eyelid			
		TOLERANCES: .005	CHECKED						
		FRACTIONAL ±	ENG APPR.						
		ANGULAR: MACH ± BEND ±	MFG APPR.						
		TWO PLACE DECIMAL ±	Q.A.						
		THREE PLACE DECIMAL ±	COMMENTS:						
		INTERPRET GEOMETRIC TOLERANCING PER:				SIZE	DWG. NO.	REV	
		MATERIAL: steel music wire				A	12062	A	
NEXT ASSY	USED ON	FINISH				SCALE: 1:1		WEIGHT:	SHEET 1 OF 1
APPLICATION		DO NOT SCALE DRAWING							