



Early View

Original article

Low-cost, easy-to-build non-invasive pressure support ventilator for under-resourced regions: open source hardware description, performance and feasibility testing

Onintza Garmendia, Miguel A. Rodríguez-Lazaro, Jorge Otero, Phuong Phan, Alexandrina Stoyanova, Anh Tuan Dinh-Xuan, David Gozal, Daniel Navajas, Josep M. Montserrat, Ramon Farré

Please cite this article as: Garmendia O, Rodríguez-Lazaro MA, Otero J, *et al.* Low-cost, easy-to-build non-invasive pressure support ventilator for under-resourced regions: open source hardware description, performance and feasibility testing. *Eur Respir J* 2020; in press (<https://doi.org/10.1183/13993003.00846-2020>).

This manuscript has recently been accepted for publication in the *European Respiratory Journal*. It is published here in its accepted form prior to copyediting and typesetting by our production team. After these production processes are complete and the authors have approved the resulting proofs, the article will move to the latest issue of the ERJ online.

Low-cost, easy-to-build non-invasive pressure support ventilator for under-resourced regions: open source hardware description, performance and feasibility testing

Onintza Garmendia^{1,2}, Miguel A. Rodríguez-Lazaro¹, Jorge Otero^{1,3}, Phuong Phan⁴, Alexandrina Stoyanova⁵, Anh Tuan Dinh-Xuan⁶, David Gozal⁷, Daniel Navajas^{1,3,8}, Josep M. Montserrat^{2,3,9}, Ramon Farré^{1,3,9,*}

¹Unitat de Biofísica i Bioenginyeria, Facultat de Medicina i Ciències de la Salut, Universitat de Barcelona, Barcelona, Spain

²Sleep Lab, Hospital Clinic, Universitat de Barcelona, Barcelona, Spain

³CIBER de Enfermedades Respiratorias, Madrid, Spain

⁴Hue Central Hospital, Hue, Vietnam

⁵Department of Economics, Faculty of Economics and Business, Universitat de Barcelona, Barcelona, Spain,

⁶Service de Physiologie-Explorations Fonctionnelles, Hôpital Cochin, Assistance Publique-Hôpitaux de Paris (AP-HP), Paris, France

⁷Department of Child Health, The University of Missouri School of Medicine, Columbia, MO, USA

⁸Institute for Bioengineering of Catalonia (IBEC), The Barcelona Institute of Science and Technology, Barcelona, Spain

⁹Institut d'Investigacions Biomediques August Pi Sunyer, Barcelona, Spain.

*Corresponding author: Prof. Ramon Farré
Unitat de Biofísica i Bioenginyeria
Facultat de Medicina i Ciències de la Salut
Casanova 143
08036 Barcelona, SPAIN
Email: rfarre@ub.edu.

ABSTRACT

AIM: Current pricing of commercial mechanical ventilators in low/middle-income countries (LMICs) markedly restricts their availability, and consequently a considerable number of patients with acute/chronic respiratory failure cannot be adequately treated. Our aim was to design and test an affordable and easy-to-build non-invasive bilevel pressure ventilator to allow reducing the serious shortage of ventilators in LMICs. **METHODS:** The ventilator was built using off-the-shelf materials available via e-commerce and was based on a high-pressure blower, two pressure transducers and an Arduino Nano controller with a digital display (total retail cost <75 US\$), with construction details open source provided for free replication. The ventilator was evaluated (and compared with a commercially available device (Lumis-150, Resmed): a) in the bench using an actively breathing patient simulator mimicking a range of obstructive/restrictive disease and b) in 12 healthy volunteers wearing a high airway resistance and thoracic/abdominal bands to mimic obstructive/restrictive patients. **RESULTS:** The designed ventilator provided inspiratory/expiratory pressures up to 20/10 cmH₂O, respectively, with no faulty triggering or cycling both in the bench test and in volunteers. Breathing difficulty score rated (1-10 scale) by the loaded breathing subjects was significantly ($p<0.005$) decreased from 5.45 ± 1.68 without support to 2.83 ± 1.66 when using the prototype ventilator, which showed no difference with the commercial device (2.80 ± 1.48 ; $p=1.000$). **CONCLUSION:** The low-cost, easy-to-build non-invasive ventilator performs similarly as a high-quality commercial device, with its open-source hardware description, will allow for free replication and use in LMICs, facilitating application of this life-saving therapy to patients who otherwise could not be treated.

INTRODUCTION

Non-invasive mechanical ventilation (NIV) is a widely used and accepted treatment for chronic respiratory diseases and, in some cases, it is also an alternative to invasive ventilation options for patients with acute respiratory failure caused by a variety of aetiologies (1). Although positive pressure ventilation in low- and middle-income countries (LMIC) is most frequently provided invasively, the benefits of NIV are being increasingly recognised. Indeed, for obvious reasons of cost and ease of use, NIV appears to be not only an effective, but also a particularly suitable approach to provide respiratory support in patients living in developing low-income economies (2). This is especially relevant since in these regions the burden of critical illness is large, and is expected to increase with growing urbanization, emerging epidemics and expanding access to hospitals (2). Furthermore, the elevated cost of healthcare staffing, infrastructure needs, and onerous access to supplies have hampered the development of fully equipped intensive care units (ICU) in LMICs (3). As a consequence, the demand for cost-effective medical equipment, such as mechanical ventilators, is likely to greatly increase in those countries. Moreover, mechanical ventilators are costly, which markedly restricts their availability, and consequently the ability to adequately treat a significant number of patients with both acute and chronic respiratory failure in LMICs. These issues are all the more evident in light of the ongoing corona virus pandemic, where even industrialized economies are encountering significant shortages in the number of available ventilators to meet the demands imposed by this disease, such that availability of non-invasive respiratory support may be valuable for certain patients or as a temporary bridge (4, 5).

Philanthropic donation of medical devices may help in providing mechanical ventilators to un-resourced regions in LMICs, but these initiatives are fraught with

considerable limitations. Indeed, donation of commercially available equipment is expensive and is only partially effective since it has been reported that up to 50% of donated devices become unusable due to lack of adequate maintenance and inability to obtain spare parts (6). In addition, donations are hardly sustainable because they require long-term commitments such as to provide device servicing. In this context, alternative solutions that are based on in-house manufacturing of pressure support devices (7,8) could reduce the serious shortage of ventilators in LMICs. Accordingly, the aim of this study was to design and test a novel low-cost bilevel pressure support ventilator, and provide open access to the detailed technical information, thereby allowing for free and unrestricted replication and implementation. To ascertain adequate performance of the device, bench testing was carried out based on simulated patients with obstructive/restrictive diseases under well-controlled conditions, a common widely accepted approach to test therapeutic devices for respiratory support (9-18). Then, and following the existent literature (19-21), the prototype ventilator was tested in healthy volunteers subjected to obstructive-restrictive loaded breathing to mimic patients with respiratory diseases requiring NIV.

METHODS

Ventilator description

The ventilator was designed to be affordable and easy-to-build, providing an open-source hardware description to allow free replication. The prototype was built using off-the-shelf materials available via e-commerce: a high-pressure blower and its driver (WM7040, Ning Bo Feng Hua Wei Cheng Motor Factory, Zhejiang, China), two pressure transducers (XGZP6847005KPG, CFSensor, Wuhu, Anhui, China) and an Arduino Nano controller with a digital display. Pressure and flow were continuously measured at the outlet of the ventilator and fed into the controller which was provided with a custom-made code to detect inspirations and expirations and to accordingly trigger the inspiratory and expiratory pressures generated by the blower. The ventilator can operate in timed or spontaneous timed (ST) mode (spontaneous breaths of patients are assisted and if the patient's effort is not detected a timed breath is triggered according to a rescue frequency). The retail cost of this ventilator prototype was below 75 US\$, and includes all required electronic circuits and power source. Noteworthy, this cost could be considerably reduced by wholesale purchasing. All the technical information and detailed circuit schematics and controller code required to build this ventilator (including optional enclosure by conventional 3D printer) is available for release under free terms following the open-source hardware approach in the online supplement (Technical_Description.zip) . Figure 1 shows external and internal images of the prototype.

Bench testing

To assess the performance of the novel bilevel pressure ventilator under well-controlled conditions, the prototype was evaluated in a bench test using an active patient

simulator modelling the respiratory mechanics of patients with different levels of obstructive/restrictive diseases (Figure 2). The passive component of the respiratory system model was a variable resistance-compliance (R-C) lung model (Adult SmartLung, IMT Analytics, Switzerland). To implement an active breathing model, the passive R-C system simulating the lungs was enclosed in a cylindrical box connected to a negative pressure source (Figure 2), as explained in detail in the online supplement (Supplementary_Methods&Results.pdf). Figure 3 shows examples of the simulated pleural pressures applied to the passive model to implement active patient models, which combined 2 breathing frequencies (15 and 20 breaths/min) and 3 negative peak pressure amplitudes (-6, -9, -12 cm H₂O). Four respiratory R-C systems were set for testing the ventilator, mimicking a patient with mild disease, a purely obstructive patient (increased R), a purely restrictive patient (reduced compliance) and a patient with both obstruction and restriction (Table 1). Two breathing frequencies were used and different inspiratory efforts were set according to the level of disease (Table 1). As shown in Figure 2, the performance of the ventilator prototype was assessed by connecting it to the patient simulator through flexible conventional tubing (2 m length, 22 mm diameter), including a 5 mm diameter orifice at the nasal mask to create an intended air leak orifice to avoid rebreathing, as it is set in conventional clinical applications. The experimentally measured pressure-flow (P-V') relationship in this intended leak ($V' \approx 10 \cdot P^{0.48}$; V' in l/min, P in cmH₂O) resulted in a minimum continuous air flow renewal of 20 l/min for a nasal pressure of 4 cmH₂O. In addition to the intentional air leak, we eventually also included a non-intentional air leak (5 mm diameter orifice) to simulate the real-life leaks observed in patients subjected to non-invasive ventilation owing to poor mask fit on the patient's face skin (Table 1). This unintended leak created

air flow leaks of 30 and 40 l/min at nasal pressure values of 10 and 18 cmH₂O, respectively.

Therefore, the ventilator prototype was tested under 16 different simulated conditions (Table 1), covering real life settings when applying NIV in clinical practice. For the sake of comparison, the same 16 bench test conditions were also applied to a high-performance commercially available mechanical ventilator (Lumis 150, VPAP ST, Resmed; with default settings). During the tests, nasal pressure, flow and simulated pleural pressure signals were measured (Figure 2) with a Fleisch pneumotachograph (Metabo, Switzerland) and pressure transducers (Celesco, Canada; Validyne, USA), recorded at 100 Hz. Subsequently, tidal volumes were digitally computed by integration of the flow signal (after adequate zero-flow correction). Inspiratory trigger delay was measured as the time from starting the decrease in negative inspiratory (simulated pleural) pressure to the time at which nasal pressure started to be positive (22).

Ventilator testing in healthy volunteers

The ventilator prototype was tested in 12 healthy volunteers (5 of them women) recruited from the university environment. Their mean age was 32.4±5.8 years and their body mass index was 23.3±2.0 kg/m² (mean±SE). To mimic the respiratory load corresponding to a patient requiring NIV the volunteers were instrumented to increase their airway resistance and to decrease their respiratory compliance, as explained in detail in the online supplement (Supplementary_Methods&Results.pdf). The protocol was carried out by one respiratory physiotherapist expert in NIV. The volunteer subject was sitting in a comfortable armchair and was equipped with a finger pulse oximeter for monitoring oxygen saturation (WristOx₂, Model 3150, Nonin Medical, Plymouth). First, he/she was allowed to get familiar with the use of a nasal mask and NIV for 3 minutes.

To this end, he/she was connected to a non-invasive ventilator (Lumis 150, VPAP ST, Resmed) through conventional nasal mask and tubing, with inspiratory and expiratory pressures set to 8 and 4 cmH₂O, respectively. Subsequently, the subject was equipped with the resistive and restrictive loads and breathed spontaneously (unsupported) for 2 min. After that period of loaded breathing, the volunteer was asked to score his/her breathing discomfort sensation on a visual analog scale where 1 would correspond to spontaneous normal breathing and 10 to the maximum breathing discomfort he/she could consider unbearable. Then, he/she was connected to a mechanical ventilator with inspiratory and expiratory pressures set to 16 and 6 cmH₂O, respectively, in spontaneous trigger (ST) mode with a backup frequency of 12 breaths/min. This ventilator was either the prototype under test or a commercially available high-performance device (Lumis 150, VPAP ST, Resmed; default settings), determined at random. At the end of a 2 min period, the subject was again asked to score his/her breathing discomfort and, without interruption nor notice to the subject, the ventilator was shifted to the other device for 2 min and then the volunteer was asked again for scoring discomfort. This process of alternating the ventilator (prototype or commercial) was repeated twice more. The discomfort scoring finally assigned to each ventilator was the mean score of the 3 periods corresponding to each device. Any faulty triggering or cycling, as observed through inspection of the real time nasal pressure signal and subject's breathing activity, was registered by the physiotherapist.

Statistics

In the bench test, the different investigated variables were assessed by comparing the data obtained with the prototype and the commercial ventilator by means of a paired t-test. In the test with voluntary subjects, discomfort scores when the individual was not mechanically supported and when supported by the two ventilators

were compared by paired t-test for normally distributed variables and by Wilcoxon signed rank test for non-normally distributed variables. A value of $p < 0.05$ was considered statistically significant.

RESULTS

Bench testing

Figure 4 shows an example of the nasal pressure and breathing flow signals recorded in one of the bench tests simulating a patient with mild disease for both the prototype and commercial ventilators. The pressure waveform in the commercial device was close to a square signal whereas the pressure generated by the prototype increased and decreased more smoothly. Consistently, the inspiratory flow induced by the commercial ventilator experienced a sudden increase at the beginning of inspiration, while the flow induced by the prototype increased more progressively.

The ventilator prototype performance was comparable to the commercial ventilator and provided inspiratory and expiratory pressures (up to 16 and 8 cmH₂O, respectively) with no defective triggering or cycling when tested over the described 16 different simulated conditions. Figure 1.Suppl (on line Supplementary_ Methods&Results.pdf) shows the pressure waveforms recorded in the 16 test conditions, showing that the prototype was performant in all cases (as the commercial device was; figures not shown). Figure 5.A is a Bland-Altman type plot illustrating the difference between measured maximum inspiratory and minimum expiratory pressures and the corresponding target values set at the ventilator control panel, respectively. Actual minimal expiratory pressures set to range 4-8 cmH₂O, differed by less than 1 cmH₂O from the target values, with positive and negative differences in the case of the prototype and commercial ventilator, respectively. Actual peak inspiratory pressures, set

to range 10-16 cmH₂O, were systematically higher than the target values for both ventilators, being greater (by ≈ 1.5 cmH₂O) in case of the prototype ventilator. The trigger delay in the prototype showed no statistically significant differences when compared with the delay time in the commercial ventilator (Figure 5.B). Although statistically significant, the inspiratory tidal volumes achieved with both ventilators in the 16 different test conditions were similar (difference of 40 ml on average) (Figure 5.B).

Test in healthy volunteers with loaded breathing

Testing in volunteers with resistive and restrictive loads provided positive results on the feasibility of the ventilator prototype for application in humans. As expected from healthy subjects, no decrease in oxygen saturation was observed throughout the whole test period when compared with the unsupported baseline ($97.0 \pm 1.3\%$): $96.8 \pm 1.0\%$ ($p=0.51$) and $96.8 \pm 0.9\%$ ($p=0.23$) when supported with the prototype and commercial ventilator, respectively. As shown in Figure 6, discomfort scoring when the 12 subjects were subjected to respiratory loading was 5.45 ± 1.68 . These values significantly decreased to 2.83 ± 1.66 ($p < 0.005$) when the loaded patient's breathing was supported by the prototype ventilator. Interestingly, the relief in breathing difficulty was virtually the same as the one achieved with the high-performance commercial ventilator (2.80 ± 1.48 ; $p=1.000$). No significant differences were observed in the variability across the 3 measurements of breathing discomfort ($p=0.208$; average standard deviation of 0.61). Figure 7 presents an example of the nasal pressure and flow signals when the prototype ventilator, set to considerable values of NIV inspiratory and expiratory pressures, was applied to a loaded-breathing volunteer, illustrating that the pressure waveform was suitable, and that the ventilator smoothly followed the breathing pattern of the subjects since no faulty triggering of cycling was detected. Figure 2.Suppl (in the

Supplementary_-Methods&Results.pdf) shows that the prototype ventilator was able to trigger mandatory ventilation cycles in case of absence of subject's inspiratory effort.

DISCUSSION

Here we describe a very low cost bilevel pressure support ventilator which is easy-to-build for potential use in under-resourced areas of developing countries or during pandemic conditions such as those imposed currently by the novel corona virus disease superimposed on already strained hospital conditions dealing with the influenza season. The results obtained during both the bench testing, and during the applicability pilot study in humans confirmed that the newly designed low-cost ventilator performs comparably to currently available commercial ventilators. Specifically, the device functioned as expected under stressing conditions in both the bench test (high load impedance and unintended leaks) and in the test with subjects with obstructive-restrictive loaded breathing.

The ventilator is based on a modular structure (Fig. 1.B) requiring only basic electronic training for an overall straightforward and easy assembly. The device modules are interconnected by compact electrical wiring, and therefore such design enables simple replacement of each module independently, as needed. The setting requires no pre-calibration routines, since pressure transducers are thermally corrected, and are provided with factory calibration. Interestingly, when the ventilator is switched on, an automatic routine process automatically tests and digitally corrects any drift in the zero signal of the transducers. Flow is sensed with a pneumotachograph consisting of a slight constriction in the tube section separating the two pressure transducers. As such orifice-like resistor is nonlinear, the pressure drop signal across the transducers is digitally linearized (by computing the square root) in real time. Given that cycling (end inspiration) is determined when inspiratory flow reaches below a certain percentage

(usually 30-50% (23), selectable by the user) of the inspiratory peak, the flow signal does not require calibration. In addition to the hardware components, the Arduino code controlling the ventilator (which is also open access provided) can be re-uploaded at any time, thereby allowing for simple updates to the ventilator functions in LMICs, with locally or remotely updated code. For instance, cheap high (or low) pressure acoustic alarms can be easily added. Moreover, the non-linear resistor to estimate flow can be replaced by a linear pneumotachograph to measure flow, and the related inspired volume (although this would increase cost and require periodic calibration). Furthermore, the ventilator control can be adapted to take into account the pressure drop induced by a humidifier in case this component is connected between the ventilator output and the tube connecting to the patient's mask. Noteworthy, the proposed approach for ventilator construction empowers the final users in LMICs to fully control the procedure, to adapt it to the local conditions, and to update the used components in response to market availability. Moreover, continued support from and collaboration with experienced teams abroad is easy and readily feasible. In a time when the most complex devices appear to be needed and can only be provided by a very competitive and specialized industry, the simplicity and performance of this designed low cost device reminds us of the need to go back to the basics, inasmuch as the rationale and implementation of NIV has not changed substantially from the pioneering times when this therapy was developed (24).

The bench test was carried out using a commonly used type of actively breathing patient simulator (9-11,16,18), mimicking a wide spectrum of patient's respiratory mechanical alterations (obstruction and/or restriction), and including normal and high breathing frequencies. Moreover, the ventilator was tested under conditions reproducing an unintended leak, a circumstance frequently encountered during clinical NIV practice.

The 16 different bench test settings (Table 1) used to test the ventilator covered the wide range of conditions that non-invasive ventilators are exposed to in real-life clinical applications. The bench test showed that, regardless of the stressing test conditions, the prototype ventilator provided the target bilevel pressures (Figure 5.A) with no faulty triggering or cycling, and with a suitable triggering delay (Figure 5.B), thereby enabling good synchronization with the inspiratory effort of the simulated patient. The relative simplicity of the feedback control system in the prototype ventilator explains the slightly different shape of pressure waveform observed over the wide range of test conditions (Figure 5.A), and also facilitates interpretation of the determinants of the small increases in peak inspiratory pressures. Whereas the commercial device applied an almost square pressure signal, the pressure waveform generated by the prototype exhibited progressive increase and decrease in inspiratory pressures (Figure 4). This is consistent with the fact that the commercial device used as a comparator was probably equipped with a more powerful (and hence expensive) feedback system to control its blower. However, several other commercially available ventilators exhibit patterns of inspiratory pressures similar to those observed in the prototype (Figure 4.A) (24). In fact, the slope of the ramp of increasing inspiratory pressure is one of the parameters that can be set by the user in some commercially available devices, since excessively rapid increases in early onset of inspiratory pressures may lead to patient discomfort (Figure 4.B) by not mimicking the physiological inspiratory patterns characterized by progressive increases in flow. Although tidal volume was not a direct outcome variable controlled by pressure support ventilators, it is interesting to note that the prototype ventilator resulted in tidal volumes that were similar to the ones generated by the commercial device (Figure 5.B), adding further support to the suitability of the

prototype ventilator for generating inspiratory pressure waveforms and adequate tidal volumes in a wide spectrum of simulated patients (Table 1).

The applicability pilot study was carried out in healthy volunteers subjected to obstructive and restrictive breathing loads. This model is widely used in the literature to simulate the mechanical load of the respiratory system for investigating ventilation (19-21) and for simulating dyspnoea (26,27). In fact, the level of obstruction-restriction we applied to our volunteers resulted in a breathing discomfort score (Figure 7) similar to the ones set in recent reports to mimic dyspnoea by loaded breathing (26,27). The results obtained when testing the applicability of the prototype ventilator in humans showed that, similar to the bench test, there were no faulty triggering or cycling events, that the pressure waveform was similar to those typically observed in commercial ventilators (Figures 7 and 2.Suppl), and that the relief of breathing discomfort was virtually the same as the one achieved by the commercial ventilator (Figure 6).

In addition to methodological and technical issues discussed above, the work presented here requires that we specifically address two aspects that are usually lacking in medical device studies: a) industrial/commercial model and b) safety/ethical issues. Indeed, in this work we propose an alternative procedure for building ventilators in-house and locally, i.e., outside the conventional medical device industrial market. There is little doubt that industry-based conventional production chains, including design, manufacturing and commercialization, play a key role in the healthcare system. Accordingly, industry heavily invests in R&D and translates new knowledge from the laboratory bench to patient bedside. In other words, the medical device industry searches and delivers life-enhancing innovative solutions. Unfortunately, such industrially-based model is hardly suitable to low-income settings that are usually resource scarce, and where the provision of even adequate basic services to the

population is challenging. The main reason why the conventional industrial model does not work in LMICs is that the standard industrial production scheme, which also applies to entirely non-for-profit companies, entails significant costs beyond those strictly required for device manufacturing.

The vast majority of medical device companies are small and medium-sized, employing less than 50 people, both in Europe (95% of all medical technology firms) and in the USA (80%) (28). Moreover, those companies, mainly based in USA and Canada (49% of the world market), Europe (27%), Japan (7%) and China (6%), are highly and globally regulated to guarantee the safety and performance of their innovative and high technology products throughout their life-cycle, as well as pre-and post-marketing (28). Unlike many other industries, R&D expenditures represent a significant cost component for medical device companies. These companies spend on average between 6% and 12% of revenues towards R&D investment (29), with some niche firms or start-ups incurring even higher R&D costs (> 20%). Average selling, general and administrative expenses (SG&A), which include marketing, advertising and promotion costs and general and administrative costs, account for about one-third of total revenues (30). Importantly, the cost of goods sold (COGS), which measures the total cost that it takes for a medical device company to manufacture its products including labour, material costs, rental and utility costs, represent between 35% and 40% of revenues (30), with the remaining costs going to taxes, interests and depreciation. Thus, a disproportionately large share of medical device companies' revenues is slated for expenses beyond those needed to manufacture their products. In contrast, in the approach we describe in this work, as ventilator assembly is performed locally or directly linked local technical partners, the only costs incurred are those associated with purchasing of the components and the actual labor costs of assembling

the device, both of which are low thanks to e-commerce and labor costs in LMICs, respectively. Noteworthy, the approach proposed here may not only allow for adequate availability of ventilators to patients (31-34), but may also contribute to the development of the local industry network in LMICs (35-37).

Regarding safety and ethical issues, it is important to emphasize that the development and testing of the NIV devices that are available in market nowadays, was made possible by development of devices built in-house by physicians and researchers in developed countries, and that these innovations were designed, tested and improved in patients before the corresponding labeling was obtained (24). Notwithstanding, the in-house ventilator proposed here does not have the conventional FDA/CE approvals. Obviously, such approval procedures are tremendously important for ensuring that medical devices placed into the market are safe and reliable and, as such, have contributed to the progress currently achieved in health care. However, obtaining FDA/CE labels is a process devised mainly for the industry in developed countries and is extremely expensive in terms of LMICs financial resources. Although these countries do not have the complex infrastructure required for such costly processes, simplified or ad-hoc approval procedures could be provided by local authorities or hospital Ethical Boards. However, particularly in light of the non-existent alternative of using industrial ventilators, i.e., leaving the patient untreated with the attendant consequences. Under such difficult circumstances, the ethical trade-off towards compassionate use of medical devices, a mechanism already in place for non-labelled therapies in developed countries, may be considered.

In conclusion, we have designed a low-cost easy-assembly ventilator with excellent performance characteristics in both the bench and in voluntary subjects. If as anticipated from these preliminary results, clinical field tests are favourable, this

low-cost device may enable provision of respiratory support to patients in LMICs who otherwise would have no access to this potentially life saving therapy, as well as escalation of ventilatory support availability in strenuous circumstances such as those imposed by respiratory virus pandemics.

REFERENCES

1. Rochwerg B, Brochard L, Elliott MW, Hess D, Hill NS, Nava S, et al. Official ERS/ATS clinical practice guidelines: noninvasive ventilation for acute respiratory failure. *Eur Respir J* [Internet]. 2017 Aug 31;50(2):1602426. <http://erj.ersjournals.com/lookup/doi/10.1183/13993003.02426-2016>
2. Mandelzweig K, Leligdowicz A, Murthy S, Lalitha R, Fowler RA, Adhikari NKJ. Non-invasive ventilation in children and adults in low- and low-middle income countries: A systematic review and meta-analysis. *J Crit Care* [Internet]. 2018 Oct;47:310–9. <https://linkinghub.elsevier.com/retrieve/pii/S0883944117302472>
3. Murthy S, Leligdowicz A, Adhikari NKJ. Intensive Care Unit Capacity in Low-Income Countries: A Systematic Review. Azevedo LCP, editor. *PLoS One* [Internet]. 2015 Jan 24;10(1): e0116949. <http://dx.plos.org/10.1371/journal.pone.0116949>
4. Truog RD, Mitchell C, Daley CQ. The Toughest Triage — Allocating Ventilators in a Pandemic. *New Eng J Med*, in press. DOI: 10.1056/NEJMp2005689.
5. Wang D, Hu B, Hu C, Zhu F, Liu X, Zhang J, Wang B, Xiang H, Cheng Z, Xiong Y, Zhao Y, Li Y, Wang X, Peng Z. Clinical Characteristics of 138 Hospitalized Patients With 2019 Novel Coronavirus-Infected Pneumonia in Wuhan, China. *JAMA*. 2020 Feb 7. doi: 10.1001/jama.2020.1585.

6. Howie SRC, Hill SE, Peel D, Sanneh M, Njie M, Hill PC, et al. Beyond good intentions: lessons on equipment donation from an African hospital. *Bull World Health Organ* 2008;86:52–56. 5.
7. Farré R, Trias G, Solana G, Ginovart G, Gozal D, Navajas D. Novel Approach for Providing Pediatric Continuous Positive Airway Pressure Devices in Low-Income, Underresourced Regions. *Am J Respir Crit Care Med* [Internet]. 2019 Jan;199(1):118–20. <https://www.atsjournals.org/doi/10.1164/rccm.201808-1452LE>
8. Farré R, Montserrat JM, Solana G, Gozal D, Navajas D. Easy-to-build and affordable continuous positive airway pressure CPAP device for adult patients in low-income countries. *Eur Respir J*. 2019;53(5).
9. Lujan M, Sogo A, Pomares X, Monso E, Sales B, Blanch L. Effect of Leak and Breathing Pattern on the Accuracy of Tidal Volume Estimation by Commercial Home Ventilators: A Bench Study. *Respir Care* [Internet]. 2013 May 1;58(5):770–7. <http://rc.rcjournal.com/cgi/doi/10.4187/respcare.02010>
10. Carreaux G, Lyazidi A, Cordoba-Izquierdo A, Vignaux L, Jolliet P, Thille AW, et al. Patient-Ventilator Asynchrony During Noninvasive Ventilation. *Chest* [Internet]. 2012, Aug;142(2):367–76. <https://linkinghub.elsevier.com/retrieve/pii/S0012369212604498>.
11. Olivieri C, Costa R, Conti G, Navalesi P. Bench studies evaluating devices for non-invasive ventilation: critical analysis and future perspectives. *Intensive Care Med* [Internet]. 2012 Jan 29;38(1):160–7. <http://link.springer.com/10.1007/s00134-011-2416-9>
12. Farré R, Montserrat JM, Rigau J, Trepas X, Pinto P, Navajas D. Response of Automatic Continuous Positive Airway Pressure Devices to Different Sleep

- Breathing Patterns. *Am J Respir Crit Care Med* [Internet]. 2002 Aug 15;166(4):469–73. <http://www.atsjournals.org/doi/abs/10.1164/rccm.2111050>
13. Rigau J, Montserrat JM, Wöhrle H, Plattner D, Schwaibold M, Navajas D, et al. Bench Model To Simulate Upper Airway Obstruction for Analyzing Automatic Continuous Positive Airway Pressure Devices. *Chest* [Internet]. 2006 Aug;130(2):350–61. <https://linkinghub.elsevier.com/retrieve/pii/S0012369215518485>
14. Isetta V, Navajas D, Montserrat JM, Farré R. Comparative assessment of several automatic CPAP devices' responses: a bench test study. *ERJ Open Res* [Internet]. 2015 May;1(1):00031–2015. <http://openres.ersjournals.com/lookup/doi/10.1183/23120541.00031-2015>
15. Isetta V, Montserrat JM, Santano R, Wimms AJ, Ramanan D, Woehrle H, et al. Novel Approach to Simulate Sleep Apnea Patients for Evaluating Positive Pressure Therapy Devices. Cymbalyuk G, editor. *PLoS One* [Internet]. 2016 Mar 15;11(3):e0151530. <https://dx.plos.org/10.1371/journal.pone.0151530>
16. Farré R, Navajas D, Montserrat JM. Technology for noninvasive mechanical ventilation: Looking into the black box. *ERJ Open Res*. 2016;2(1):1–11.
17. Zhu K, Farré R, Katz I, Hardy S, Escourrou P. Mimicking a flow-limited human upper airway using a collapsible tube: relationships between flow patterns and pressures in a respiratory model. *J Appl Physiol* [Internet]. 2018 Aug 1;125(2):605–14. <https://www.physiology.org/doi/10.1152/jappphysiol.00877.2017>
18. Bunburaphong T, Imanaka H, Nishimura M, Hess D, Kacmarek RM. Performance Characteristics of Bilevel Pressure Ventilators. *Chest* [Internet]. 1997

Apr;111(4):1050–60.

<https://linkinghub.elsevier.com/retrieve/pii/S0012369215468709>

19. Eberlein M, Schmidt GA, Brower RG. Chest wall strapping. An old physiology experiment with new relevance to small airways diseases. *Ann Am Thorac Soc*. 2014;11(8):1258–1266. doi:10.1513/AnnalsATS.201312-465OI
20. Mols G, von Ungern-Sternberg B, Rohr E, Haberthür C, Geiger K, Guttman J. Respiratory comfort and breathing pattern during volume proportional assist ventilation and pressure support ventilation: A study on volunteers with artificially reduced compliance. *Crit Care Med* [Internet]. 2000 Jun;28(6):1940–6. <http://insights.ovid.com/crossref?an=00003246-200006000-00042>
21. Mols G, Vetter T, Haberthür C, Geiger K, Guttman J. Breathing pattern and perception at different levels of volume assist and pressure support in volunteers. *Crit Care Med* [Internet]. 2001 May;29(5):982–8. <https://insights.ovid.com/crossref?an=00003246-200105000-00018>
22. Ferreira JC, Chipman DW, Kacmarek RM. Trigger performance of mid-level ICU mechanical ventilators during assisted ventilation: a bench study. *Intensive Care Med* [Internet]. 2008 Sep 30;34(9):1669–75. <http://link.springer.com/10.1007/s00134-008-1125-5>
23. Moerer O, Harnisch LO, Herrmann P, Zippel C, Quintel M. Patient-Ventilator Interaction During Noninvasive Ventilation in Simulated COPD. *Respir Care*. 2016 Jan;61(1):15-22. doi: 10.4187/respcare.04141. Epub 2015 Nov 10. PubMed PMID: 26556898.
24. Sullivan CE. Nasal Positive Airway Pressure and Sleep Apnea. Reflections on an Experimental Method That Became a Therapy. *Am J Respir Crit Care Med*. 2018

- Sep 1;198(5):581-587. doi: 10.1164/rccm.201709-1921PP. PubMed PMID: 30011222.
25. Battisti A, Tassaux D, Janssens JP, Michotte JB, Jaber S, Jolliet P. Performance characteristics of 10 home mechanical ventilators in pressure-support mode: a comparative bench study. *Chest*. 2005 May;127(5):1784-92. PubMed PMID: 15888859.
26. Nierat M-C, Demiri S, Dupuis-Lozeron E, Allali G, Morélot-Panzini C, Similowski T, et al. When Breathing Interferes with Cognition: Experimental Inspiratory Loading Alters Timed Up-and-Go Test in Normal Humans. Najbauer J, editor. *PLoS One* [Internet]. 2016 Mar 15;11(3):e0151625. <http://dx.plos.org/10.1371/journal.pone.0151625>
27. Allard E, Canzoneri E, Adler D, Morélot-Panzini C, Bello-Ruiz J, Herbelin B, et al. Interferences between breathing, experimental dyspnoea and bodily self-consciousness. *Sci Rep* [Internet]. 2017 Dec 30;7(1):9990. [http://www.nature.com/articles/s41598-017-11045-x-](http://www.nature.com/articles/s41598-017-11045-x)
28. The European Medical Technology Industry – in figures 2019. <https://www.medtecheurope.org/wp-content/uploads/2019/04/The-European-Medical-Technology-Industry-in-figures-2019-2.pdf> . Last access March 24 2020.
29. Spence P, Babitt J, Welch J, De Busscher L. As change accelerates, how can medtechs move ahead and stay there? Pulse of the industry 2017. EYGM Limited. [https://www.ey.com/Publication/vwLUAssets/ey-as-change-accelerates-how-can-medtechs-move-ahead-and-stay-there/\\$FILE/ey-as-change-accelerates-how-can-medtechs-move-ahead-and-stay-there.pdf](https://www.ey.com/Publication/vwLUAssets/ey-as-change-accelerates-how-can-medtechs-move-ahead-and-stay-there/$FILE/ey-as-change-accelerates-how-can-medtechs-move-ahead-and-stay-there.pdf) . Last access Mach 24, 2020.

30. Fuhr T, George K, Pai J. The Business Case for Medical Device Quality. McKinsey Center for Government.
https://www.mckinsey.com/~media/McKinsey/dotcom/client_service/Public%20Sector/Regulatory%20excellence/The_business_case_for_medical_device_quality.ashx .
Last access Mach 24, 2020.
31. Pearce, J.M. (2015) Quantifying the Value of Open Source Hardware Development. Modern Economy, 6, 1-11. <http://dx.doi.org/10.4236/me.2015.61001>.
32. Pearce JM. Maximizing Returns for Public Funding of Medical Research with Open-source Hardware. Health Policy and Technology. 6(4), 2017, pp. 381-382.
<https://doi.org/10.1016/j.hlpt.2017.09.001>
33. Eslambolchilar P, Thimbleby H. Open-source hardware for medical devices. BMJ Innov 2016; 2: 78–83.
34. DePasse JW, Caldwell A, Santorino D, et al. Affordable medical technologies: bringing Value-Based Design into global health. BMJ Innovations 2016; 2: 4–7.
35. Mackintosh M, Tibandebage P, Karimi Njeru M, et al. Rethinking health sector procurement as developmental linkages in East Africa. Soc Sci Med 2018; 200: 182–189.
36. De Maria C, Mazzei D, Ahluwalia A. Open source biomedical engineering for sustainability in African healthcare: combining academic excellence with innovation. Proceedings of the ICDS 2014, The Eighth International Conference on Digital Society; 2014 Mar 23–27, Barcelona, Spain; pp. 48–53. www.thinkmind.org/index.php?view=article&articleid=ic

37. Clifford KL, Zaman MH. Engineering, global health, and inclusive innovation: focus on partnership, system strengthening, and local impact for SDGs. *Glob Health Action* 2016; 9: 30175. doi:10.1186/s13039-016-10173-1.

Table 1. Setting of 16 different conditions simulated for the bench test (see text for explanation).

Simulated patient	Resistance (cmH ₂ O/L/s)	Compliance (mL/cmH ₂ O)	Breathing rate (breath/min)	“Pleural” negative peak pressure (cmH ₂ O)	Inspiratory / Expiratory pressure (cmH ₂ O)	Unintended leak (at 10 cmH₂O) (l/min)
1-Mild	5	30	15	-6	9/4	No
2- Mild	5	30	15	-6	9/4	30
3- Mild	5	30	20	-6	9/4	No
4- Mild	5	30	20	-6	9/4	30
5-Obstructive	20	30	15	-9	10/5	No
6-Obstructive	20	30	15	-9	10/5	30
7-Obstructive	20	30	20	-9	10/5	No
8-Obstructive	20	30	20	-9	10/5	30
9-Restrictive	5	15	15	-12	14/6	No
10-Restrictive	5	15	15	-12	14/6	30
11-Restrictive	5	15	20	-12	14/6	No
12-Restrictive	5	15	20	-12	14/6	30
13-Obs+Rest	20	15	15	-12	16/8	No
14-Obs+Rest	20	15	15	-12	16/8	30
15-Obs+Rest	20	15	20	-12	16/8	No
16-Obs+Rest	20	15	20	-12	16/8	30

FIGURE LEGENDS

Figure 1. Low-cost ventilator prototype. Top: front View. Bottom: internal View showing the main modules.

Figure 2. Active patient simulator to test the mechanical ventilator prototype. Passive respiratory mechanics was mimicked by a resistance (R) – compliance (C) passive model enclosed in a box. The active component inducing breathing in the model (blue color in the figure) consisted of a blower connected to the box wall. As blower flow increased, pressure in the box (simulation pleural pressure (Ppl)) progressively decreased to negative values, inducing inspiration in the R-C lung model. The actively breathing model was connected to the ventilator under test by a conventional tubing and a conventional intended leak to avoid rebreathing. An unintended leak allowed to simulate air leak caused by lack of perfect seal between the nasal mask and the patient's face skin. Pressure (P) and flow (V') were measured at the level of the nasal mask by means of transducers.

Figure 3. Examples of simulated pleural pressures in the bench test. Top: conditions 1 to 4. Center: conditions 5 to 8. Bottom: conditions 9 to 16. (see table 1 for conditions definition).

Figure 4. Example of the nasal pressure and breathing flow signals recorded in one of the bench tests simulating a patient with mild disease (condition 4). Left: prototype ventilator. Right: Lumis 150 ventilator. (see Table 1 for conditions definition).

Figure 5. (A). Pressure difference between (positive peak) inspiratory and (negative peak) expiratory pressures actually delivered by the ventilator and set at the

ventilator control panel for both Prototype and Lumis 150. (B) Inspiratory time delay and tidal volume in the prototype and Lumis 150 ventilators.

Figure 6. Discomfort scoring (Visual Analog Scale) in healthy volunteers subjected to obstructive-restrictive loaded breathing when unsupported and when supported by the prototype and Lumis 150 ventilators.

Figure 7. Example of pressure and flow signals recorded when a resistive-restrictive loaded breathing volunteer's breathing was supported by the prototype ventilator. These are unfiltered raw data from the sensors within the ventilator. The flow signal is uncalibrated in both amplitude and zero.

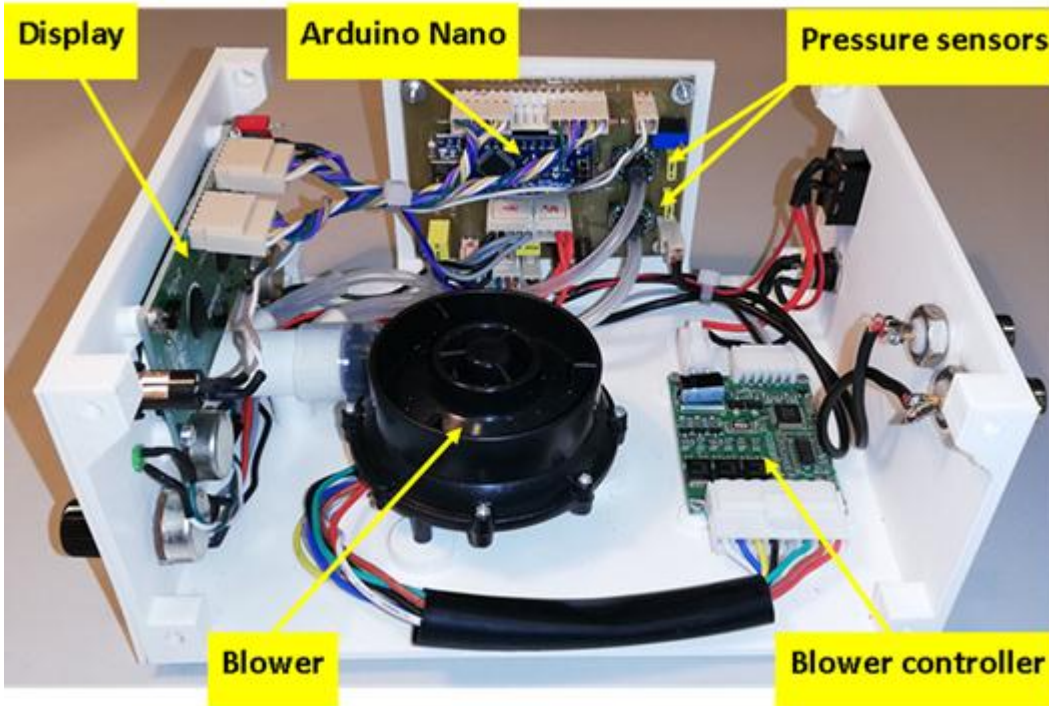

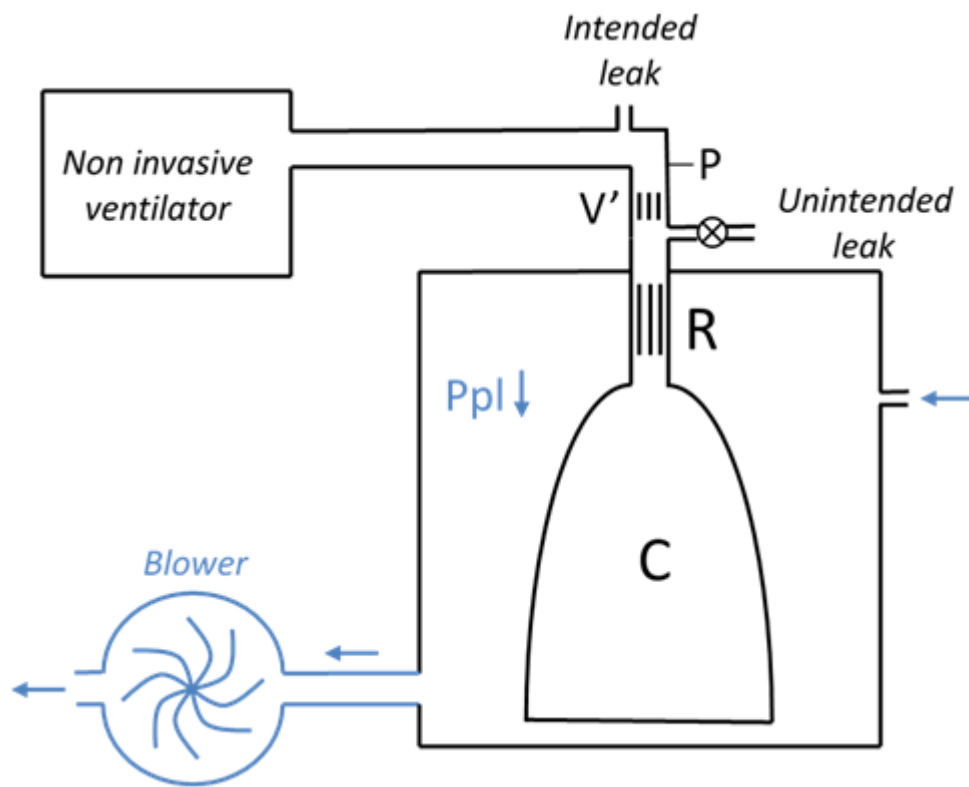

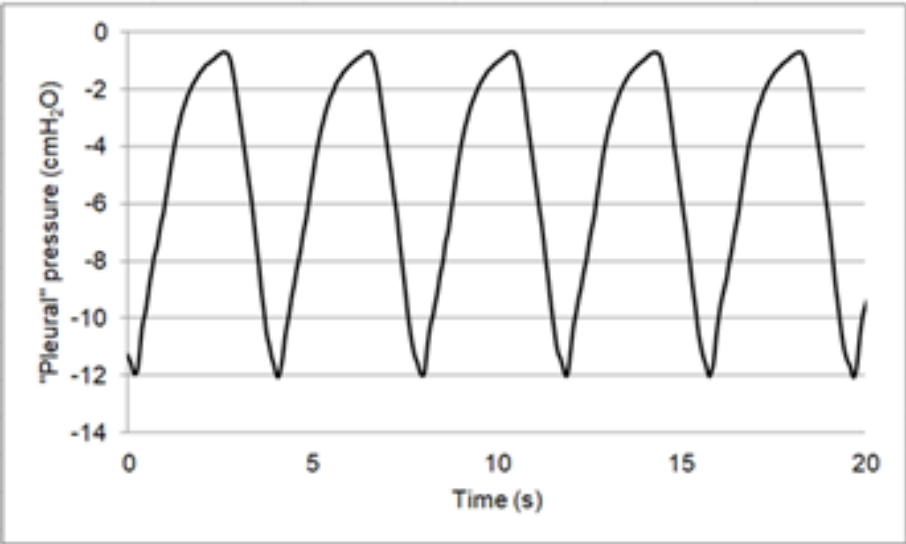
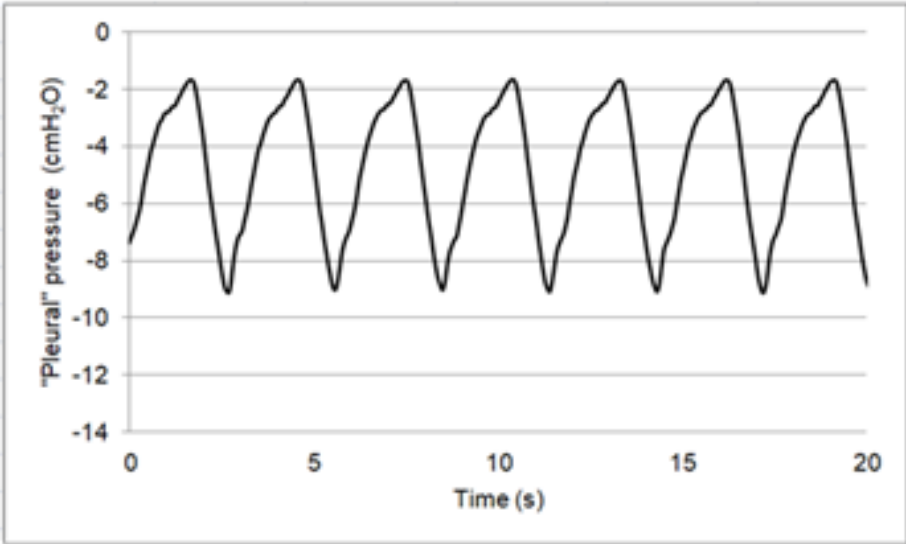
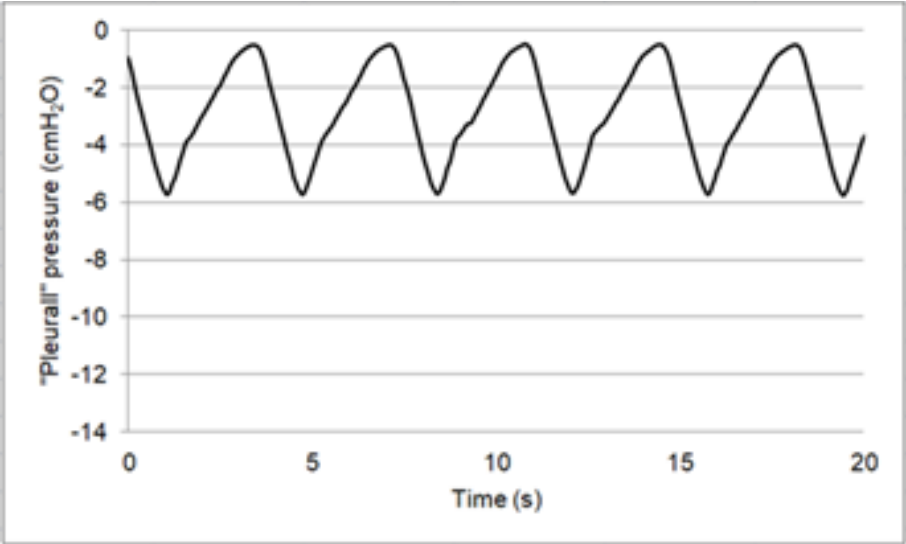

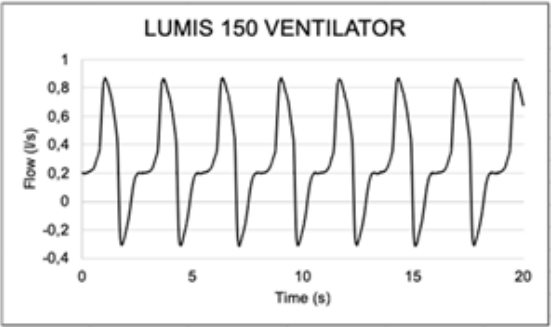
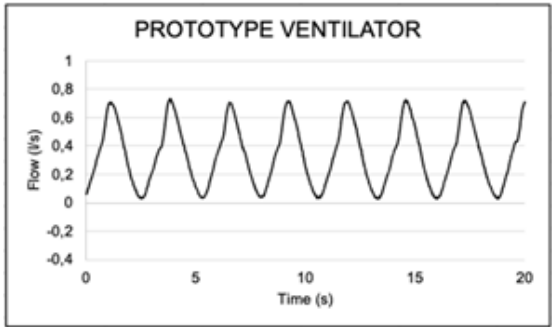
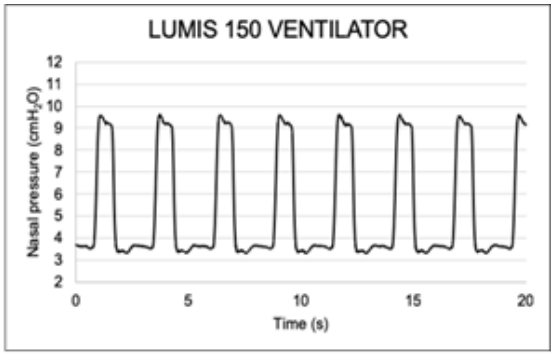
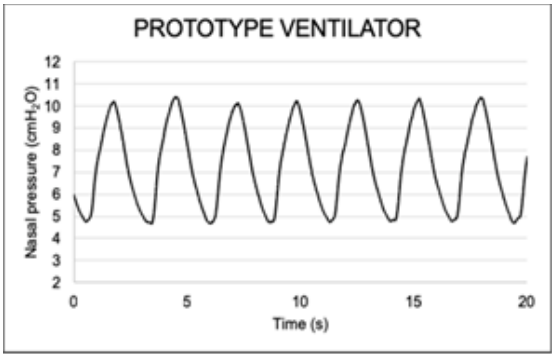

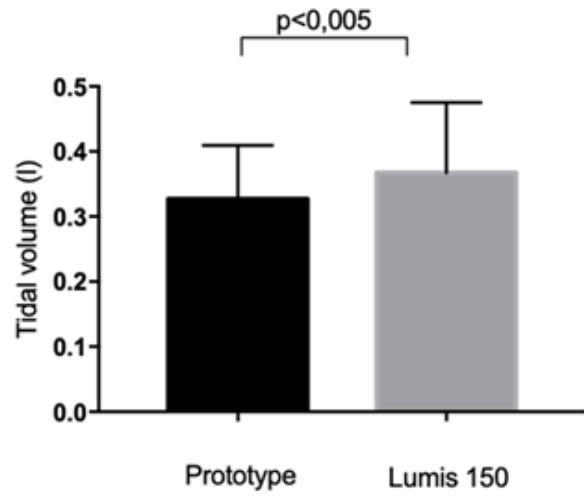
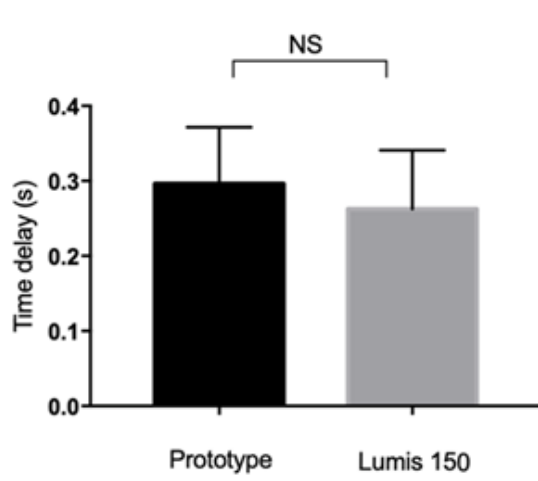
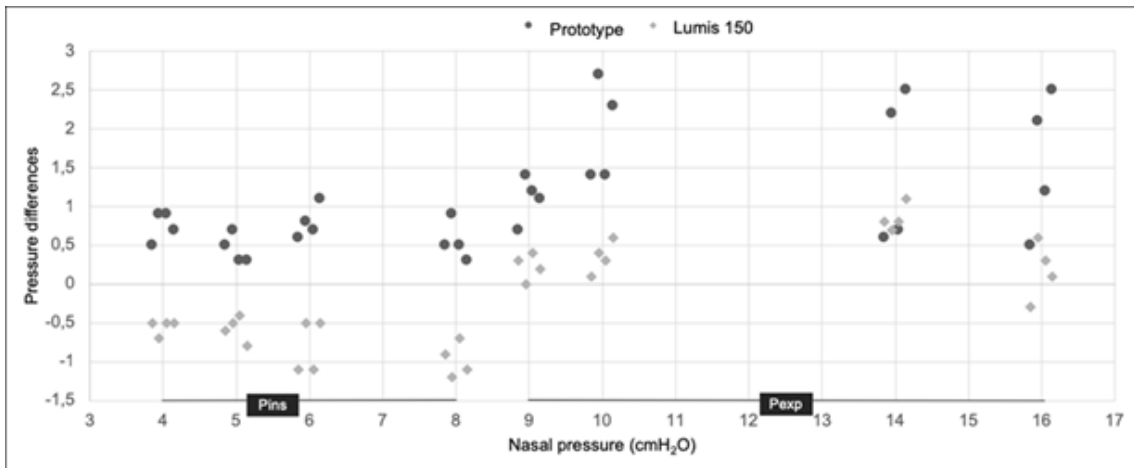

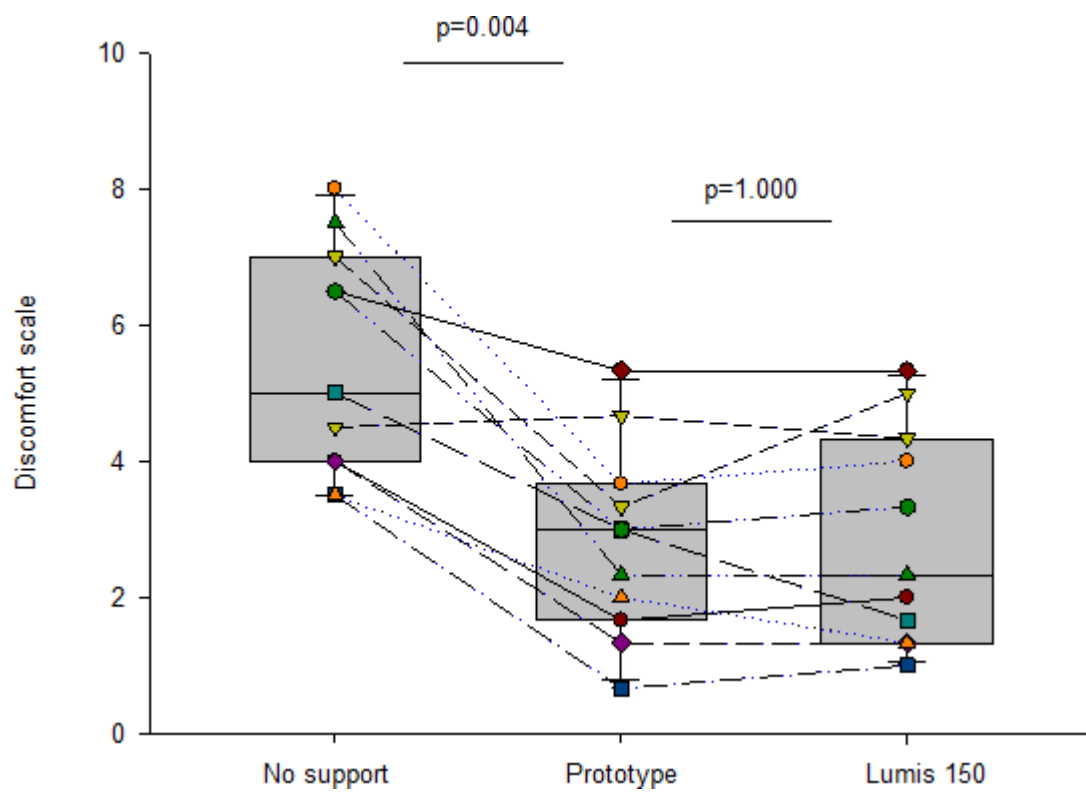

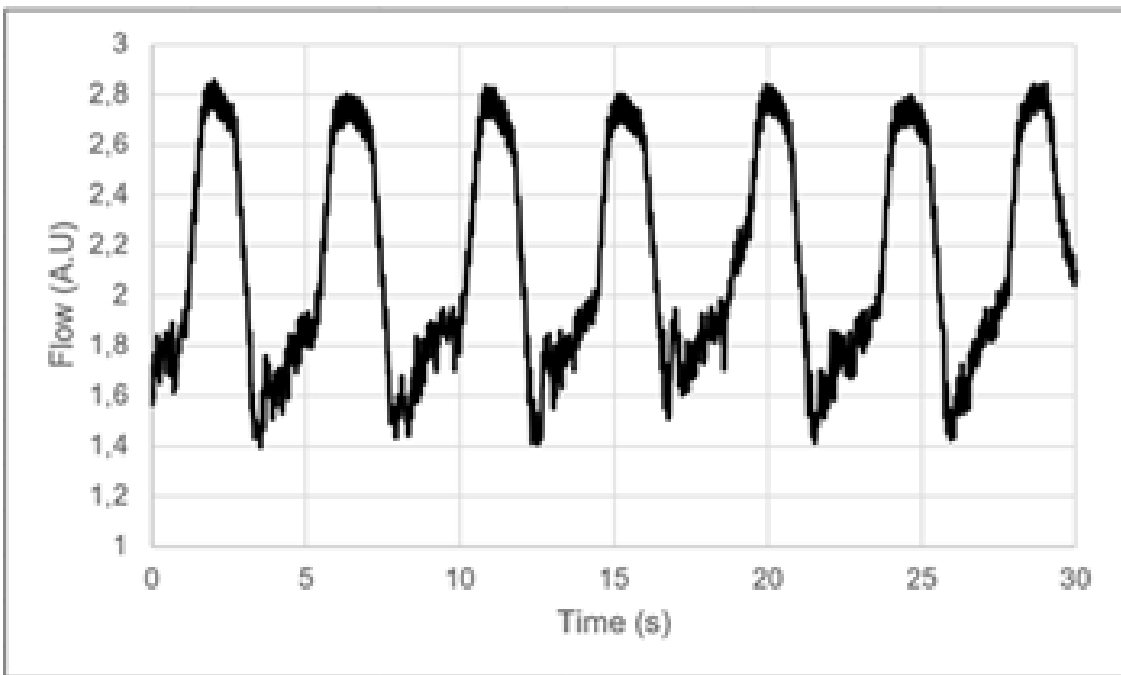
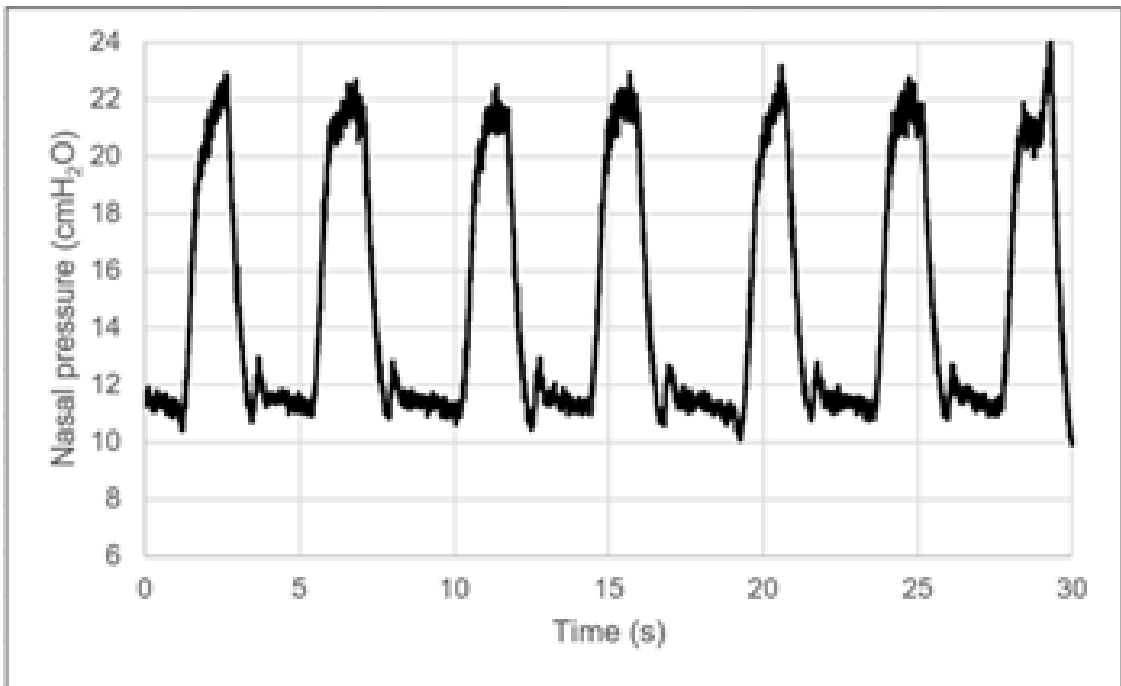

SUPPLEMENTARY METHODS AND RESULTS

Low-cost, easy-to-build non-invasive pressure support ventilator for under-resourced regions: open source hardware description, performance and feasibility testing

Onintza Garmendia^{1,2}, Miguel A. Rodríguez-Lazaro¹, Jorge Otero^{1,3}, Phuong Phan⁴, Alexandrina Stoyanova⁵, Anh Tuan Dinh-Xuan⁶, David Gozal⁷, Daniel Navajas^{1,3,8}, Josep M. Montserrat^{2,3,9}, Ramon Farré^{1,3,9,*}

¹Unitat de Biofísica i Bioenginyeria, Facultat de Medicina i Ciències de la Salut, Universitat de Barcelona, Barcelona, Spain

²Sleep Lab, Hospital Clinic, Universitat de Barcelona, Barcelona, Spain

³CIBER de Enfermedades Respiratorias, Madrid, Spain

⁴Hue Central Hospital, Hue, Vietnam

⁵Department of Economics, Faculty of Economics and Business, Universitat de Barcelona, Barcelona, Spain,

⁶Service de Physiologie-Explorations Fonctionnelles, Hôpital Cochin, Assistance Publique-Hôpitaux de Paris (AP-HP), Paris, France

⁷Department of Child Health, The University of Missouri School of Medicine, Columbia, MO, USA

⁸Institute for Bioengineering of Catalonia (IBEC), The Barcelona Institute of Science and Technology, Barcelona, Spain

⁹Institut d'Investigacions Biomediques August Pi Sunyer, Barcelona, Spain.

*Corresponding author: Prof. Ramon Farré
Unitat de Biofísica i Bioenginyeria
Facultat de Medicina i Ciències de la Salut
Casanova 143
08036 Barcelona, SPAIN
Email: rfarre@ub.edu.

METHODS

Active patient simulator.

To implement an active breathing model, the passive R-C system simulating the lungs was enclosed in a cylindrical box (20 cm diameter, 30 cm height), leaving the R-C inlet (airway opening) outside the box (Figure 2). The air in this box simulated the pleural compartment. The cylindrical box was connected to a negative pressure source based on a controlled blower (WM7040, Ning Bo Feng Hua Wei Cheng Motor Factory, Zhejiang, China). A pressure transducer (XGZP6847005KPG, CFSensor, Wuhu, Anhui, China) connected to the box chamber measured the air pressure, which played the role of pleural pressure in the model. The cylindrical box had a resistance orifice open to the room air to allow setting the level of simulated pleural pressure in combination with the amplitude of the flow generated by the blower. A half-cycle sinusoidal voltage signal driving the blower allowed to generate simulated pleural pressures realistically mimicking those induced by inspiratory muscles in terms of amplitude, frequency and time course.

Ventilator testing in healthy volunteers.

The volunteers were naïve to the pathophysiology of respiratory diseases and had never received mechanical ventilation. They were provided with detailed explanations of the procedure in a specific meeting, and signed a written consent to participate in the protocol. Each volunteer was told, in lay language, that: a) his/her respiration would be partially hindered to simulate the breathing difficulty perceived during a heavy physical work or sport practice, b) that a device to facilitate his/her breathing would then be connected through a nasal mask and c) that he/she would be asked to score the level of comfort/discomfort experienced with/without the breathing support.

To mimic the respiratory load corresponding to an obstructive patient, a mesh-wire screen resistance (9.5 cmH₂O/L/s) was placed at the inlet of a conventional

nasal mask for non-invasive ventilation. The built-in intended leak of the mask was sealed, and a 5 mm orifice intended leak open to the room air was placed between the end of the flexible tube connecting the ventilator to the mask and the 9.5 cmH₂O/L/s added resistance which hence played the role of an actual increase in patient's airway resistance. To also load the volunteer with a restrictive component, a nonflexible belt (9 cm width) was tightly fit around the abdomen and a spring-based flexible belt (9 cm width) was adjusted around the thorax at the level of the manubrium sterni.

RESULTS

Figure 1. Suppl. Pressure generated by the prototype ventilator when connected to simulated patients under different conditions without (A) and with (B) unintended air leaks. (C) and (D) are the flow signals corresponding to the pressures in (A) and (B), respectively. See Table 1 in the main manuscript for conditions definition.

(A)

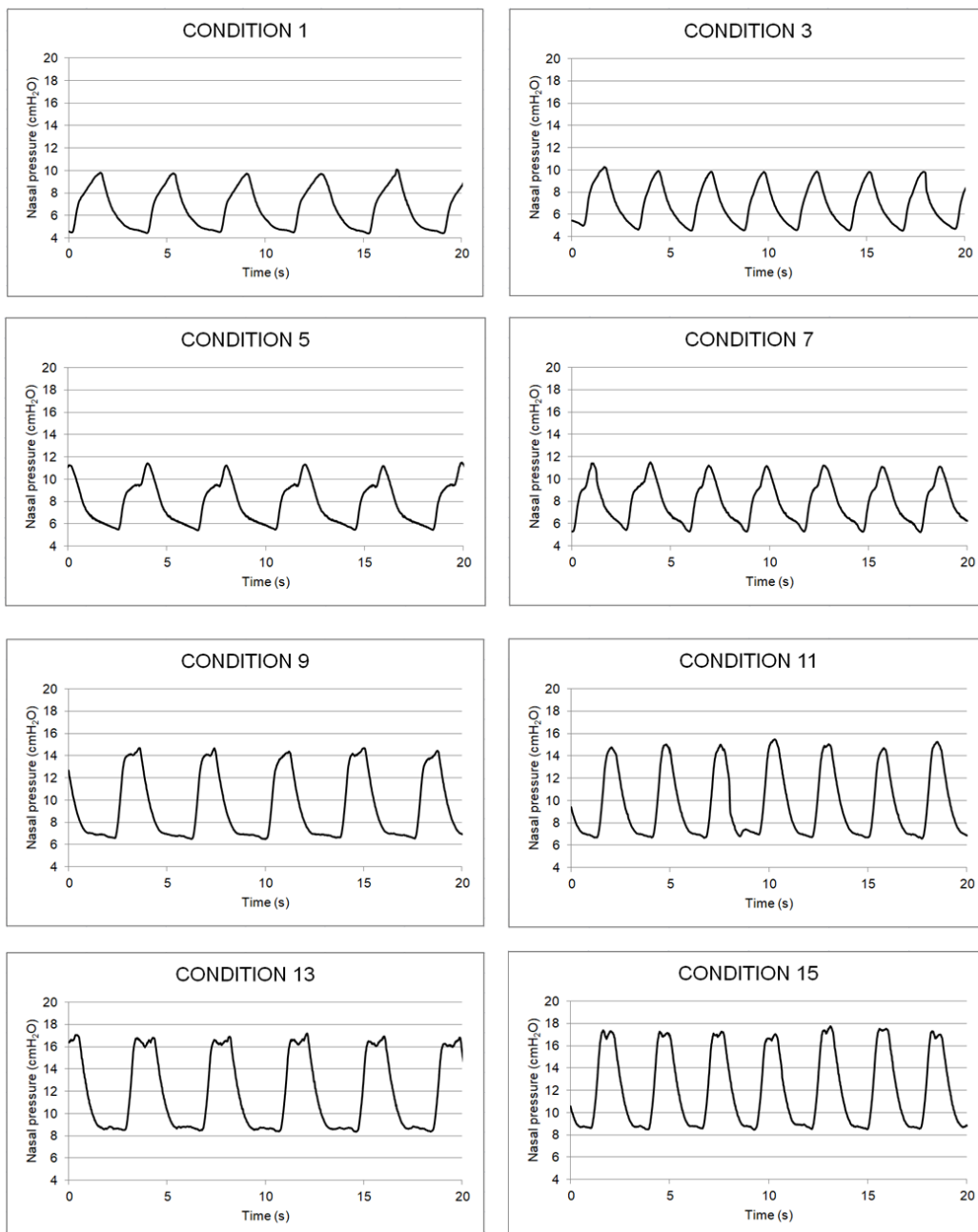

(B)

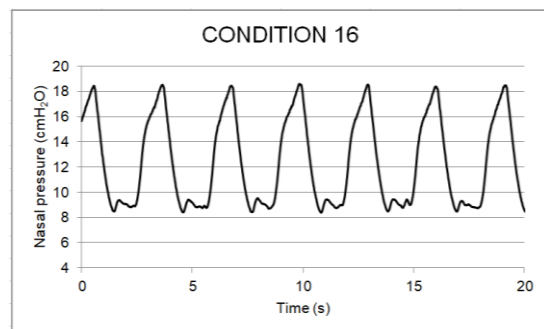
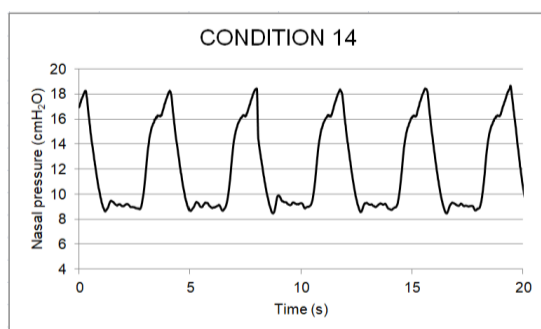
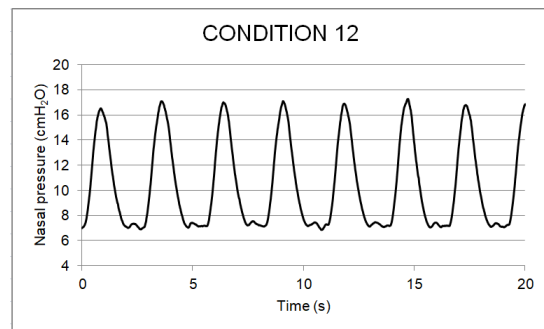
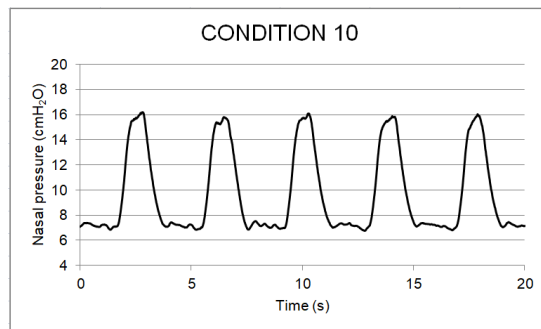
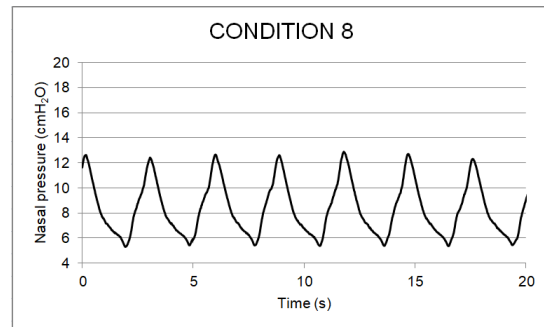
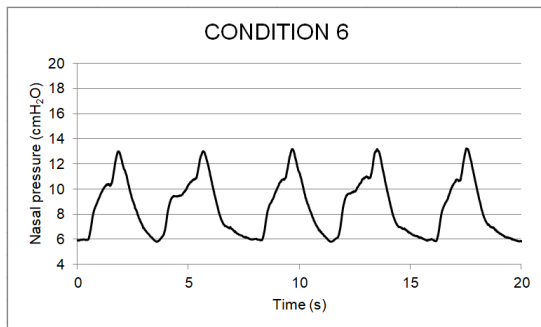
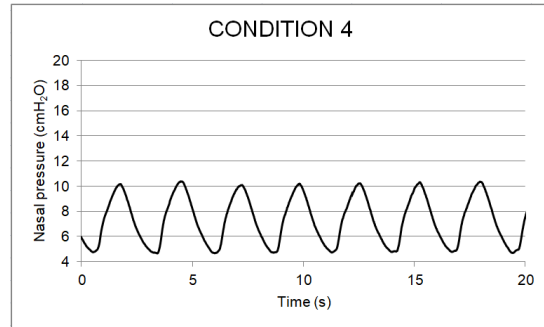
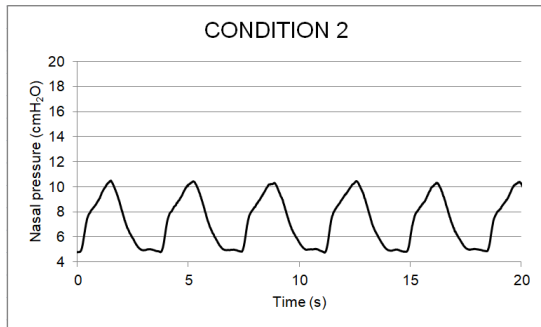

(C)

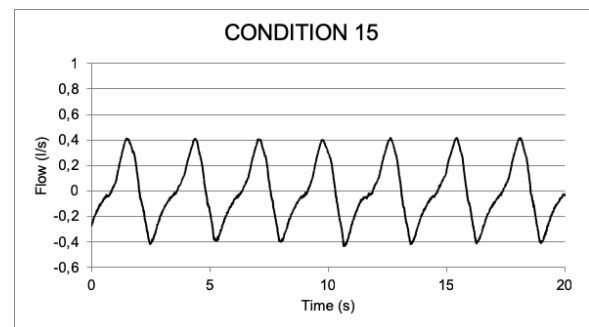
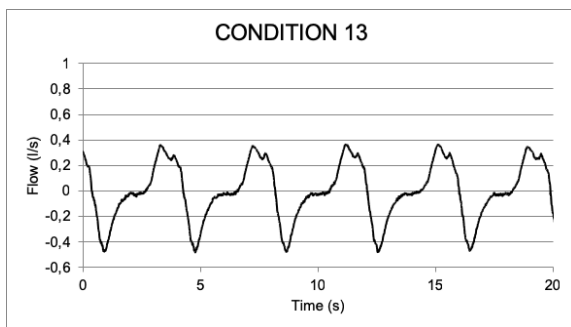
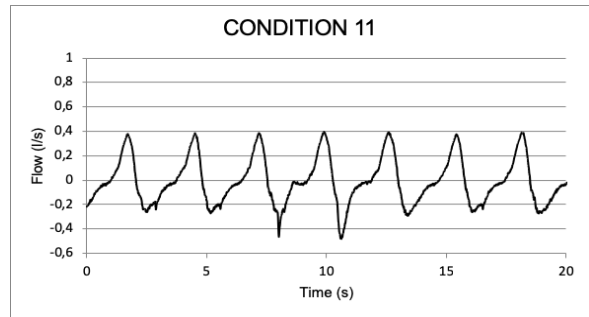
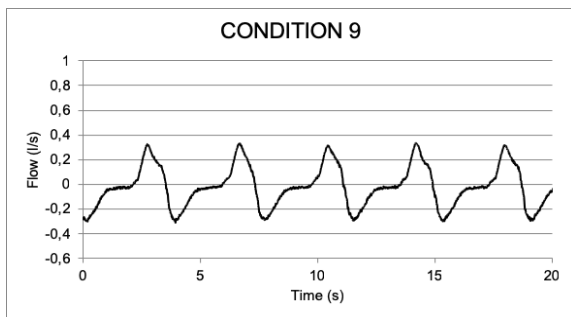
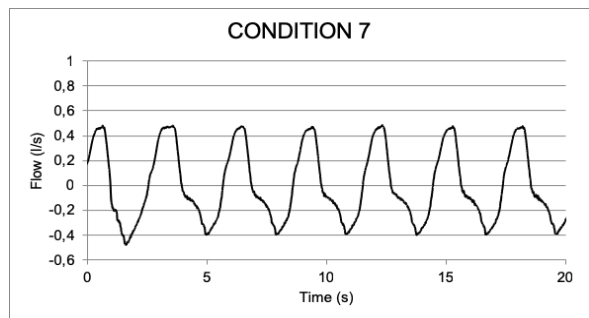
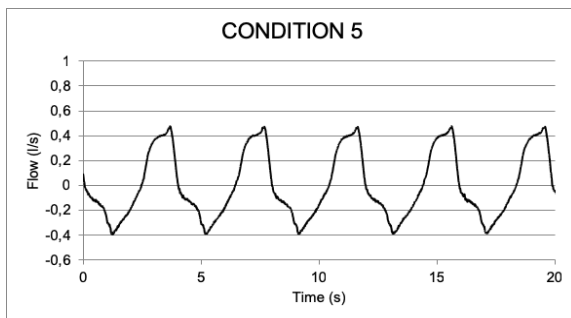
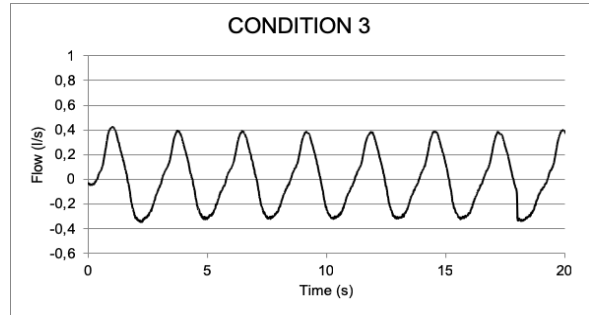
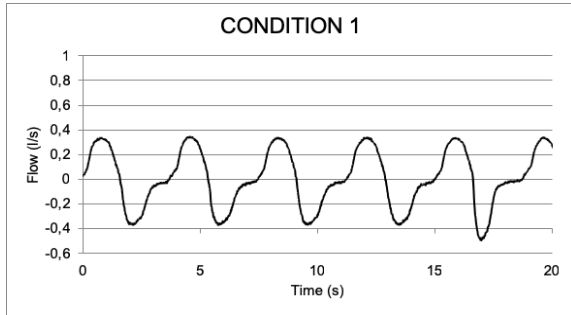

(D)

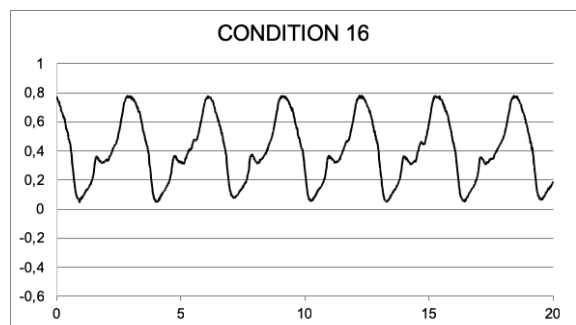
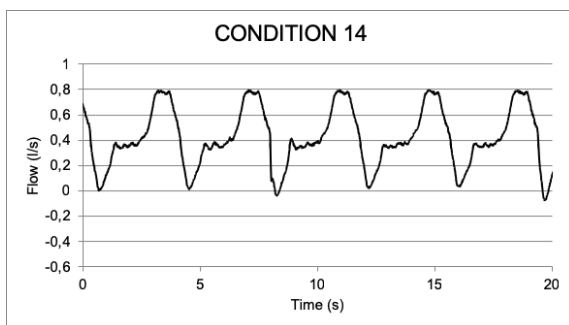
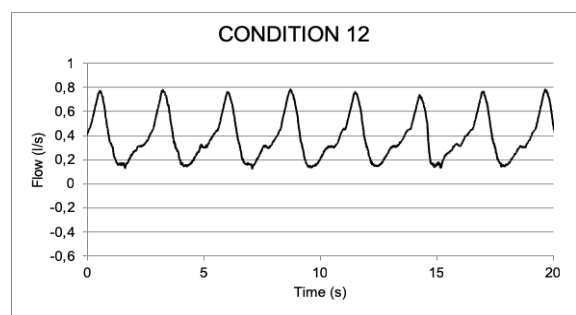
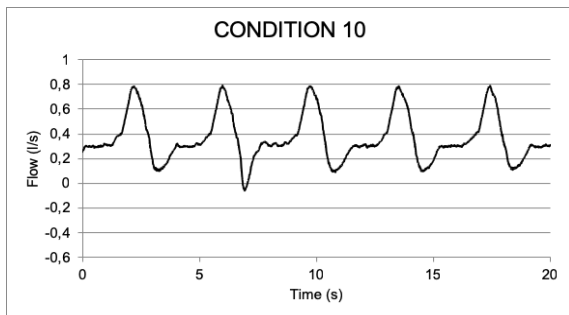
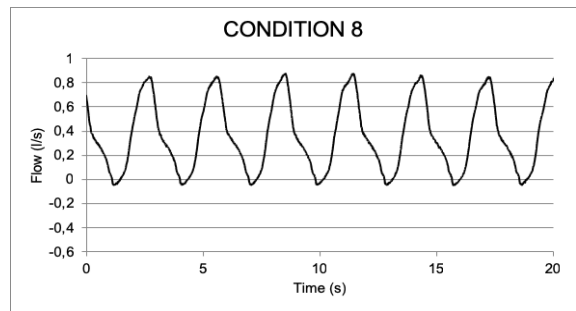
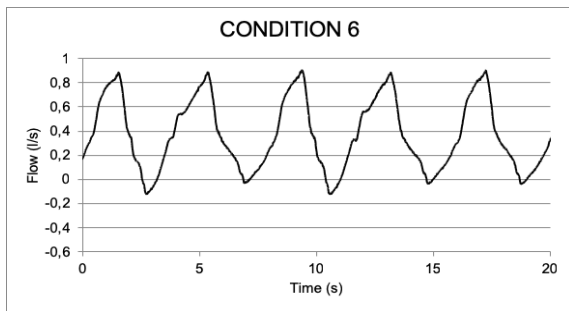
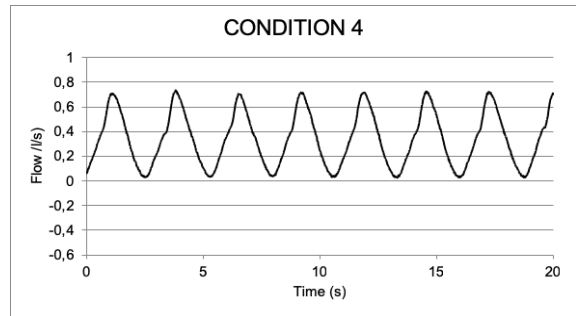
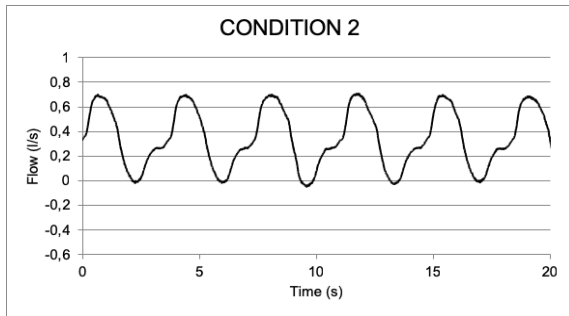

Figure 2. Suppl. Example of the nasal pressure and breathing flow signals recorded in a resistive-restrictive loaded breathing volunteer subjected to ventilatory support with the prototype ventilator. From second 12 to 30, the volunteer was asked to perform an end-inspiratory apnea with glottis closure to observe that the ventilator automatically triggered mandatory inspirations at the 12 breath/min backup frequency. Both the pressure (in cmH₂O) and flow (uncalibrated arbitrary units (a.u.)) recording correspond to the unfiltered signals from the sensors within the ventilator. The flow observed during the apnea corresponds to the flow through the intended leak corresponding to the inspiratory and expiratory pressure.

