

BOOK I

Getting acquainted with Minivac 601



Copyright © 1961

by

SCIENTIFIC
DEVELOPMENT
CORPORATION

Watertown
Mass.

...a first step
toward the exciting world of electronic
data processing via digital computers



The MINIVAC 601 computer and this book are used together to demonstrate the operation of digital computer components and to teach principles basic to their use. As you become familiar with MINIVAC 601 and understand its relationship to large digital computers, you will be performing the operations basic to a modern electronic data processing machine.

This is the first in a series of books using MINIVAC 601 to demonstrate the fundamentals of modern digital computers. This book acquaints you with MINIVAC 601. The second book in this series relates the components of MINIVAC 601 to corresponding parts of a large commercial digital computer. Other books enable you to use MINIVAC 601 to discover how these parts function to make decisions, to do arithmetic, and to do practical work for men. A book of games which may be played with MINIVAC 601 is also provided.

CONTENTS

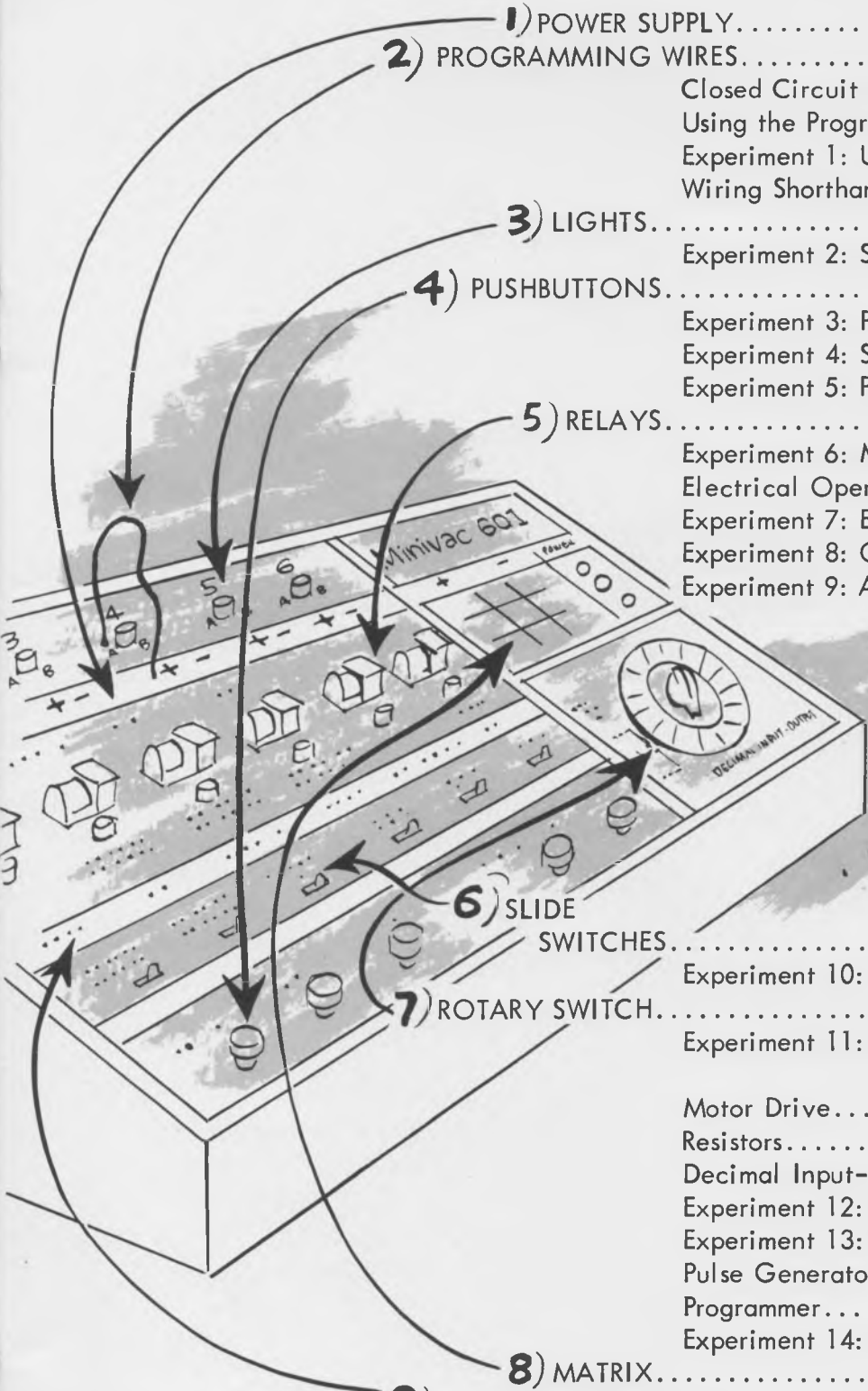

1) POWER SUPPLY	3
2) PROGRAMMING WIRES	4
Closed Circuit Principle.....	4
Using the Programming Wires.....	4
Experiment 1: Use of Programming Wires.....	5
Wiring Shorthand.....	5
3) LIGHTS	6
Experiment 2: Single Light Operation.....	7
4) PUSHBUTTONS	8
Experiment 3: Pushbutton Operation.....	9
Experiment 4: Series Circuit.....	10
Experiment 5: Parallel Circuit.....	11
5) RELAYS	12
Experiment 6: Manual Relay Operation.....	13
Electrical Operation of the Relay.....	14
Experiment 7: Electrical Relay Operation.....	15
Experiment 8: One Relay Controls Another.....	16
Experiment 9: A Relay Controls Itself.....	17
6) SLIDE SWITCHES	18
Experiment 10: Slide Switch Operation.....	19
7) ROTARY SWITCH	20
Experiment 11: Manual Operation of Rotary Switch	21
Motor Drive.....	22
Resistors.....	22
Decimal Input-Output.....	22
Experiment 12: Basic Motor Operation.....	23
Experiment 13: Motor Driven Rotary Switch.....	23
Pulse Generator.....	24
Programmer.....	24
Experiment 14: Motor Reversing.....	24
8) MATRIX	25
9) AUXILIARY TERMINALS	25
10) LOOKING AHEAD WITH MINIVAC 601	26
Summary: Book I.....	26
Book II: What is a Digital Computer?	26
Book III: How Computers Make Logical Decisions.....	26
Book IV: How Computers Do Arithmetic.....	27
Book V: How Computers Work for Man.....	27
Book VI: MINIVAC Games.....	27
PROBLEMS FOR MINIVAC 601.....	28

The Minivac Manual was prepared and edited by the staff of
Scientific Development Corporation

First Printing--August, 1961

EX LIBRIS ccapitalia.net

Copyright © 1961 by Scientific Development Corporation, 372 Main Street, Watertown, Massachusetts

1 POWER SUPPLY

The power supply converts the 110-volt AC power obtained from a standard electric outlet in your home to a safe working level of 12 volts DC. This low voltage DC is used to power MINIVAC and is connected to all terminals + and - on the power panel. Most toy electric trains use the same low-voltage power as MINIVAC and therefore working with the MINIVAC is as safe as operating an electric train.

The POWER SWITCH is used to turn power ON and OFF. The power should be OFF whenever you are wiring the computer. Following this practice will establish good working habits and will help to prevent accidental short-circuits. The power must be turned OFF when the computer is not in use. The red power light shows when the power is ON.

The red button above the power switch labeled CIRCUIT BREAKER is a safety switch which automatically turns off the power supply when it is overloaded. An overloaded circuit or a short-circuit will cause the circuit breaker to "blow" just like a household fuse. A short circuit occurs when + is wired directly to - without a component in between. The power supply may be restored to normal operation after a short-circuit by changing the faulty wiring and then pushing the red circuit-breaker button back in.

CAUTION:

Do NOT hold the circuit-breaker button in if it continues to "blow." Turn power off and determine the cause for drawing excessive current before proceeding with the experiments.

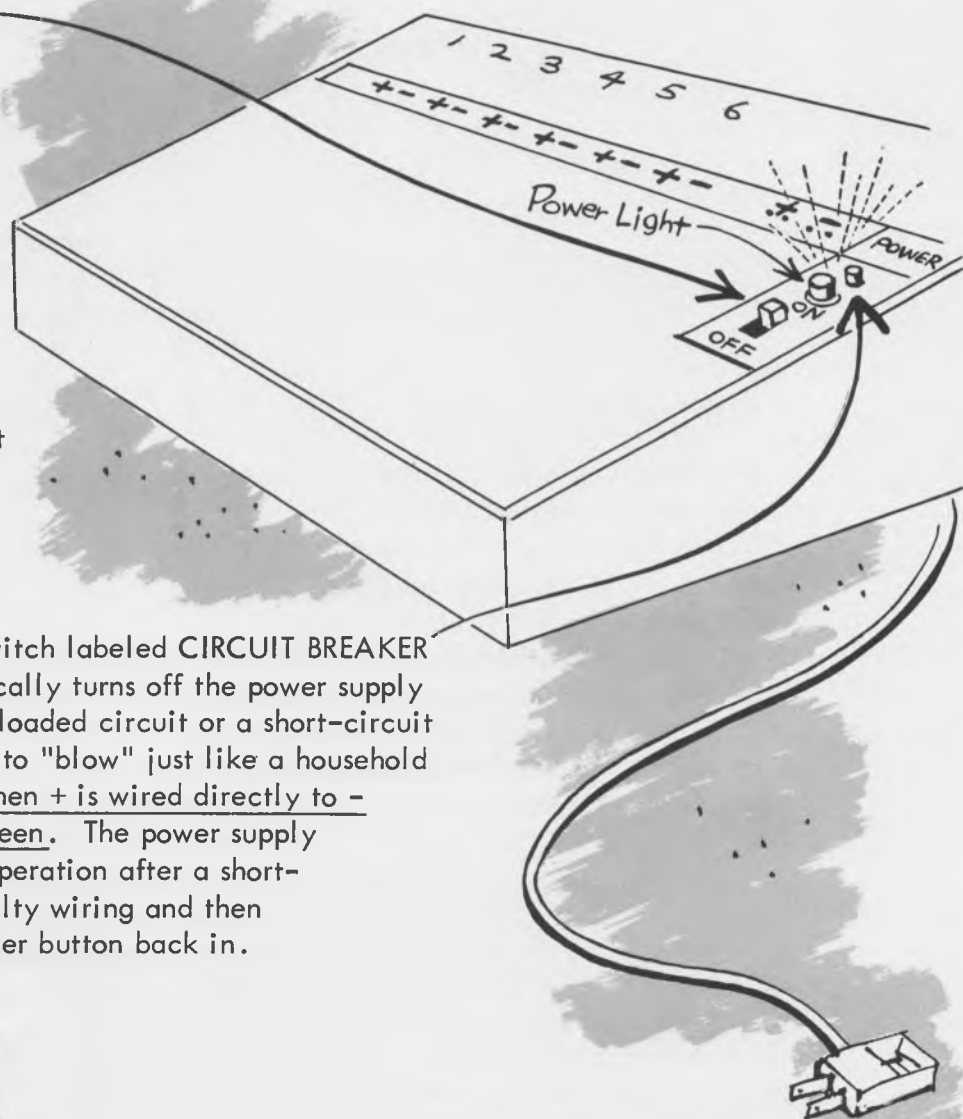

Now....plug the POWER CORD into a standard 110-volt AC (NOT DC) outlet, and you are ready to GET ACQUAINTED WITH MINIVAC 601.....

2 PROGRAMMING WIRES

Programming wires of different lengths are provided to make electrical (programming) connections between various terminals on MINIVAC 601. These wires establish closed electrical circuits and route the current through one or more components to create a desired computer circuit.

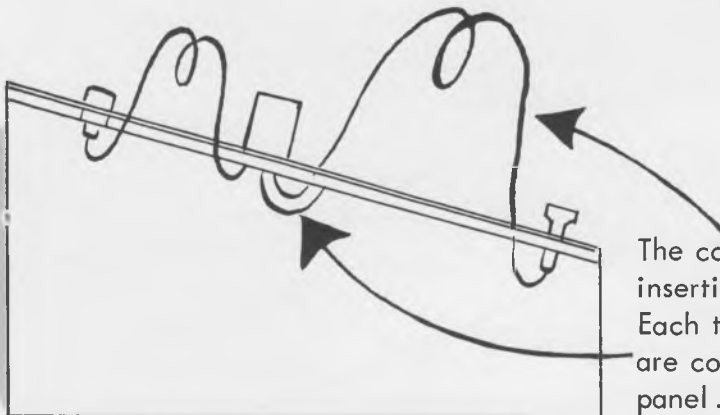

Each component in the computer is connected to nearby terminals by permanent connections made under the computer panel.

The components may be interconnected by inserting programming wires into the terminals. Each terminal has two holes side-by-side which are connected together underneath the computer panel. Programming wires may be plugged into either (or both) holes of the terminal. All programming wires are color-coded by length.

CLOSED CIRCUIT PRINCIPLE

For any electrical device to operate, it is necessary for electrical current to flow **THROUGH** the device. A closed electrical circuit must be established to let the electrons flow from the negative power supply terminal (-) through the component to the positive power supply terminal (+). Thus, all electrical components on the MINIVAC 601 require at least 2 connections to operate.

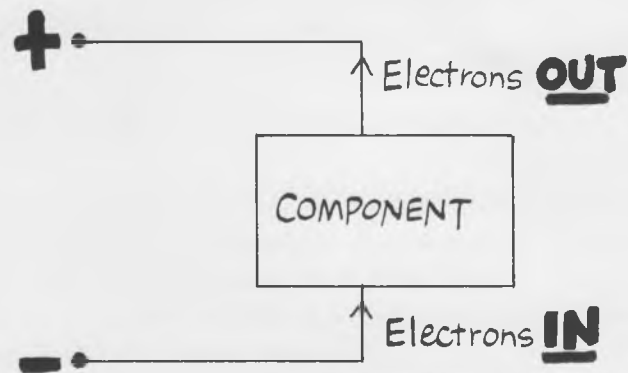

USING THE PROGRAMMING WIRES

The programming wires are used to connect various components of MINIVAC 601. Closed circuits are wired through the terminals provided on the console for each component. Each terminal is identified by a letter printed below it, and by the number printed at the top of the section in which it is located. This makes possible easy identification of terminal points when wiring components together in future experiments. We are now ready to use the programming wires.

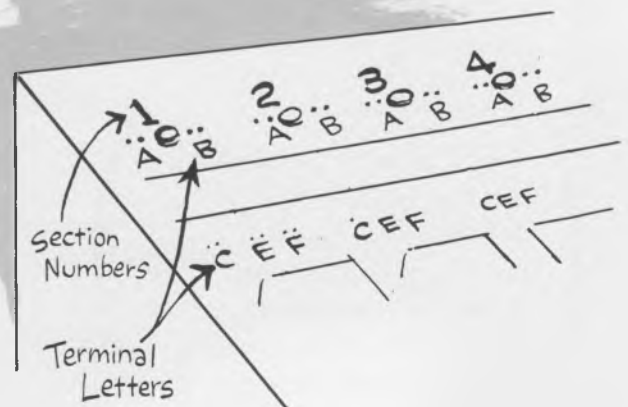

EXPERIMENT I



USE OF PROGRAMMING WIRES

This experiment demonstrates the use of programming wires to make connections on MINIVAC 601.

1) Take two programming wires. Grasp one end of the first wire firmly between your thumb and forefinger.

2) Connect this end of the programming wire to terminal 1+ on the computer panel by pushing it into one of the two holes just below the + in section 1 of the computer.

3) Take the other end of this programming wire and connect 1+ to terminal 1A by pushing it into one of the two holes just above the letter A in section 1 of the computer.

4) Similarly, connect terminal 1B to terminal 1- with the second programming wire. These connections cause lamp 1 to light when the Power Switch is turned on. This simple circuit is discussed further in Experiment 2.

5) Disconnect the programming wire by pulling both ends from the computer terminals. Do NOT disconnect the programming wires from the console by pulling on the wire because the wire may break. All programming wires should be disconnected after each experiment or problem.

WIRING SHORTHAND

A WIRING SHORTHAND is used to indicate connections which are to be made on the computer by simply writing the two terminal designations with a slash in between. In Experiment 1, terminal 1+ was connected to terminal 1A. This is written in shorthand
A series of such shorthand wiring instructions will be given to describe the wiring of a complete circuit.

→ 1+ / 1A

3 LIGHTS

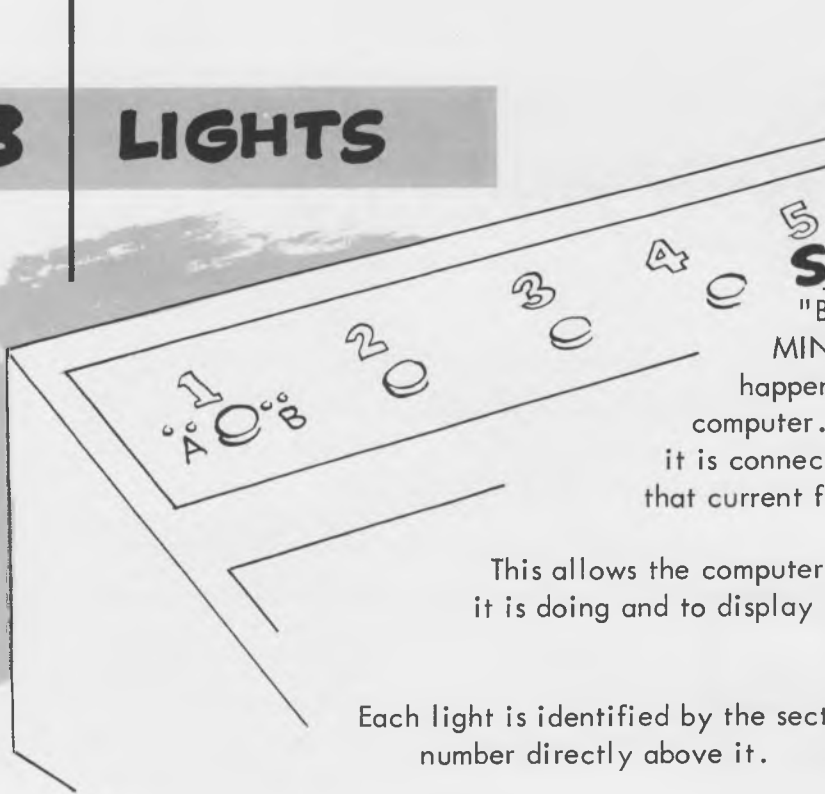

Six identical lights labeled "Binary Output" are used in MINIVAC 601 to show what is happening in various parts of the computer. A light will come on when it is connected in a closed circuit so that current flows through the light.

This allows the computer to tell an operator what it is doing and to display the answer to a computer problem.

Each light is identified by the section number directly above it.

In order for a light to turn ON (to light), current must flow THROUGH the light. The electrons must flow IN on one wire and OUT on another wire. This is the closed circuit principle for lights.

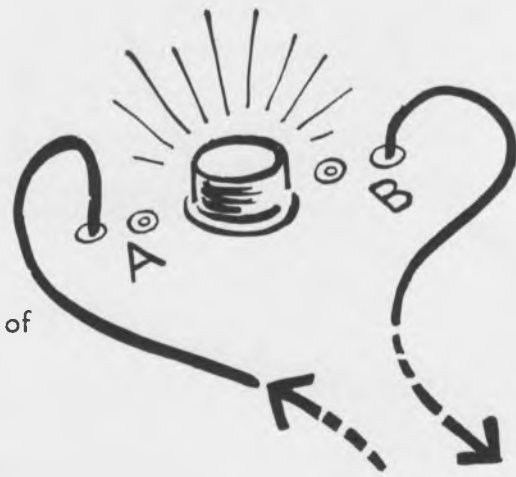

The terminals labeled A and B on either side of each light are used to supply the electrical power to turn the light ON. A light comes ON when terminal A is connected to one power supply terminal (+ or -) and terminal B is connected to the other power supply terminal (- or +).

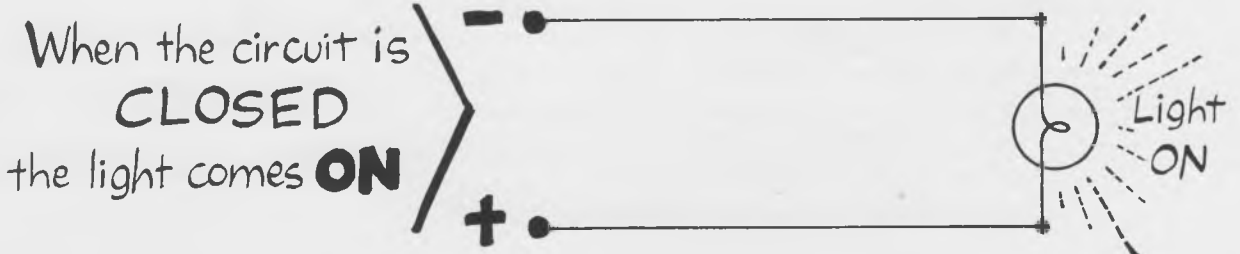
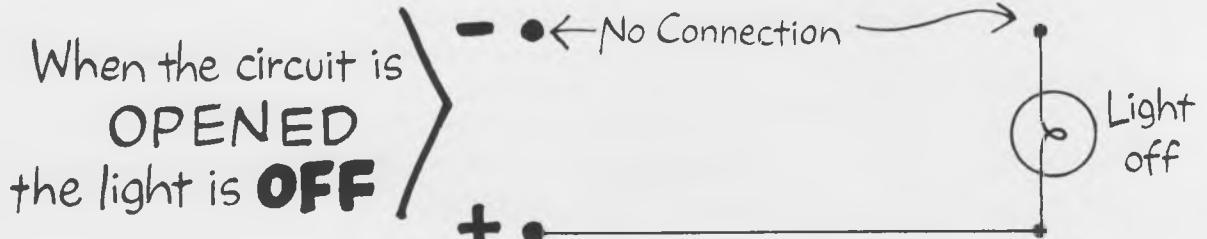

EXPERIMENT 2

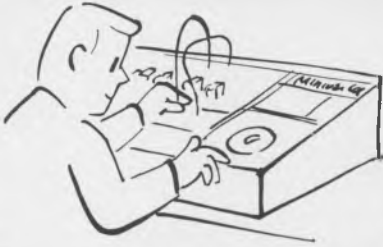

SINGLE LIGHT OPERATION

This experiment demonstrates the operation of a single binary output light.

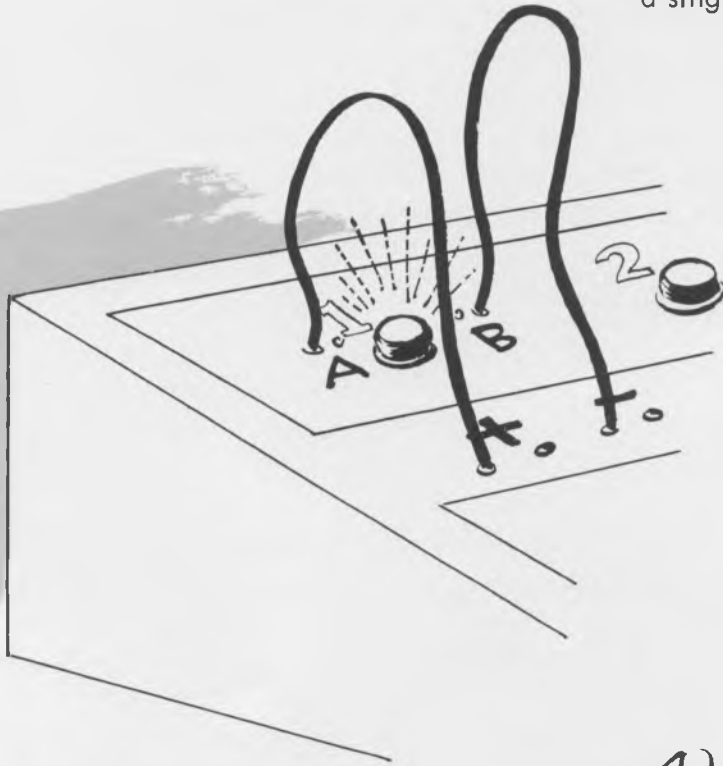

- 1) Using two short programming wires, make the connections 1+/1A and 1-/1B.
- 2) Turn the power switch ON (be sure the main power cord is plugged into a proper outlet). Light 1 comes ON because current flows through the light.
- 3) Turn the power switch OFF and disconnect the programming wires. Power should be turned OFF and all programming wires should be disconnected after each experiment is completed.

4) Any of the lights may be operated by connecting programming wires from + to A and from - to B just as was done for light 1.

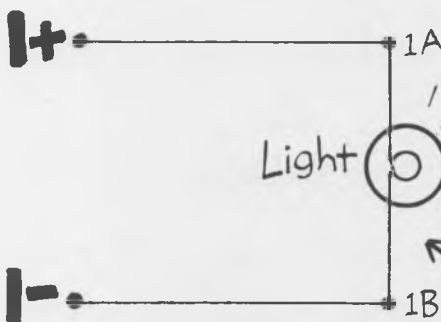

5) Make connections to two or more lights at once.

(The circuit diagram looks like this)

The lights are used in later experiments to represent numbers. The light OFF will represent a zero (0) and the light ON will represent a one (1). The numbers zero (0) and one (1) are the only numbers used in the binary number system, and it is for this reason that the lights are labeled "Binary Output." Binary numbers and their use in digital computers will be taken up later.

Binary Number System

OFF = "0"

ON = "1"

4 PUSHBUTTONS



The section of the computer panel labeled "Binary Input" contains six identical pushbuttons which are used by the operator to supply information to the computer. The pushbuttons may be used to tell the computer what to do, or to indicate the value of input numbers.

Pushbuttons may be used to control the other components of MINIVAC 601. Each pushbutton is identified by its section number on the computer panel.

Each of the six binary input pushbuttons has three terminals located directly above it on the computer panel. Each terminal is connected under the panel to a contact. The terminals are labeled X, Y and Z.

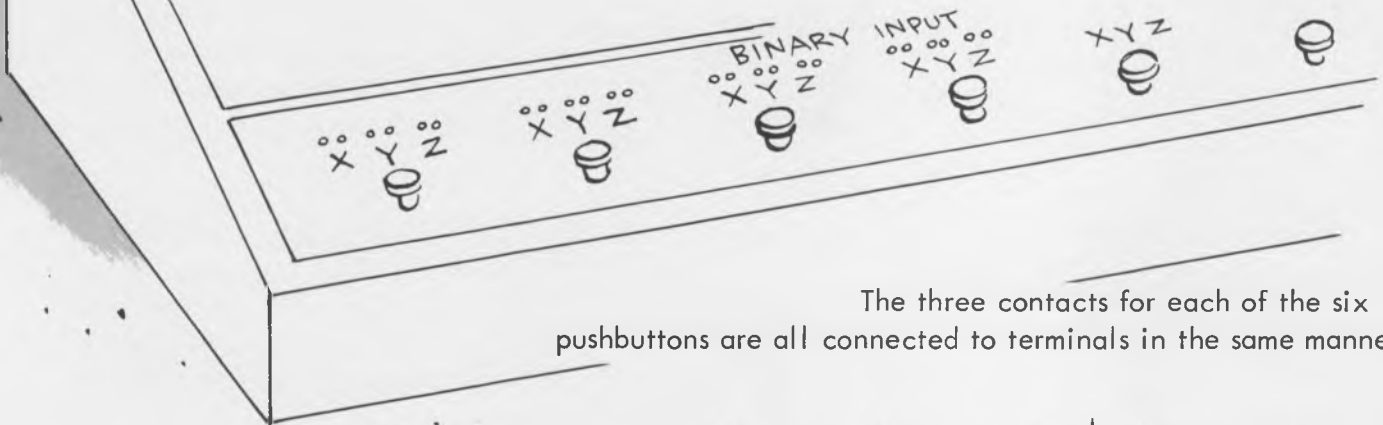

The three contacts for each of the six pushbuttons are all connected to terminals in the same manner:

When the pushbutton is UP, an electrical connection is made between terminals Y and Z. When the pushbutton is DOWN, the electrical connection is switched to terminals Y and X. Terminal Y is connected to the "common" contact and is always used when the pushbutton is connected in a circuit.

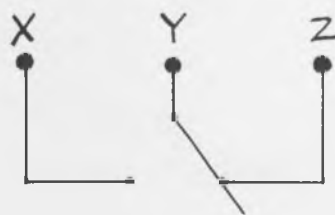

UP = Y/Z

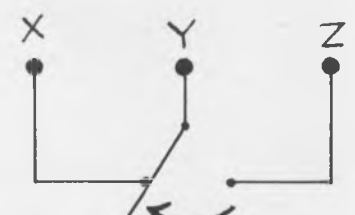

DOWN = X/Y

When a pushbutton is shown in a circuit diagram, the contacts are ALWAYS shown with the pushbutton UP - in the "normally closed" (N.C.) position. Notice that terminals X and Y are not connected when the pushbutton is UP, and that terminals Y and Z are not connected when the pushbutton is DOWN.



The following experiments demonstrate basic circuits in which one or two pushbuttons are used with a light...

EXPERIMENT 3

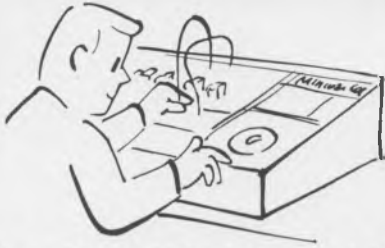

PUSHBUTTON OPERATION

This experiment uses a light to demonstrate the operation of a pushbutton. Both normally open and normally closed circuits are connected.

1) The normally open pushbutton-light circuit drawing looks like this:

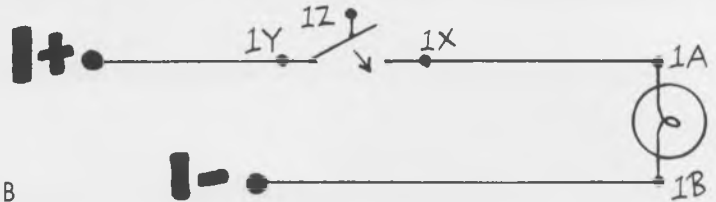

2) Program this circuit by making the following connections: 1+/1Y, 1X/1A, 1-/1B

3) Turn the power switch ON. Push DOWN on pushbutton 1. Light comes ON because the circuit from + to - is closed through the pushbutton contacts and through light 1.

4) Release the pushbutton and the light goes OFF. The light goes OFF because the circuit from + to - is open (broken) by the pushbutton contacts. Turn the power switch OFF.

5) With a normally closed pushbutton-light added, the circuit drawing looks like this: Program this by adding connections -- 1Z/2A, 2B/2-

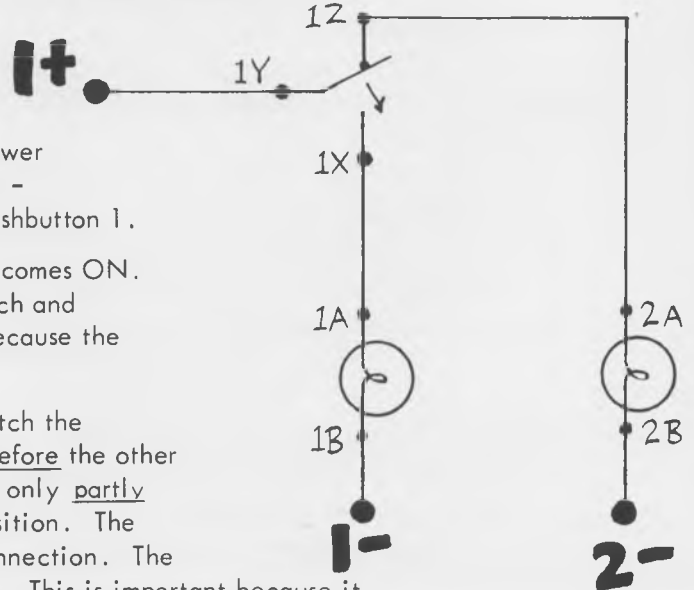

6) Turn the power switch ON. Light 2 comes on as soon as power is turned ON. Light 2 lights because the circuit from + to - is completed through the normally closed contact (Z) of pushbutton 1.

7) Push down on pushbutton 1. Light 2 goes OFF and light 1 comes ON. Light 2 goes OFF because the circuit is opened by the switch and electric current can no longer flow. Light 1 comes ON because the circuit is closed through the switch.

8) Push up and down slowly on pushbutton 1 and carefully watch the operation of the two lights. One light always goes OFF before the other light comes ON. There is a position, with the pushbutton only partly depressed, where both lights are OFF. Try to find this position. The switch breaks one connection before it makes the other connection. The pushbuttons are thus called "break-before-make" switches. This is important because it shows that the normally open contact is never connected directly to the normally closed contact, even for a very short time. This feature is necessary for the proper operation of some MINIVAC circuits.

This experiment demonstrates the two basic ways to use a pushbutton. The normally closed contact (Y/Z) may be used to complete a circuit when the pushbutton is UP, and the normally open contact (X/Y) may be used to complete a circuit when the pushbutton is DOWN.

The pushbuttons will be used in later experiments to represent numbers. The pushbutton UP will represent a Zero (0), and the pushbutton DOWN will represent a one (1). The numbers, zero (0) and one (1) are the only numbers used in the binary number system, and it is for this reason that the pushbuttons are labeled "Binary Input." Binary numbers, and their use in digital computers, will be taken up later.

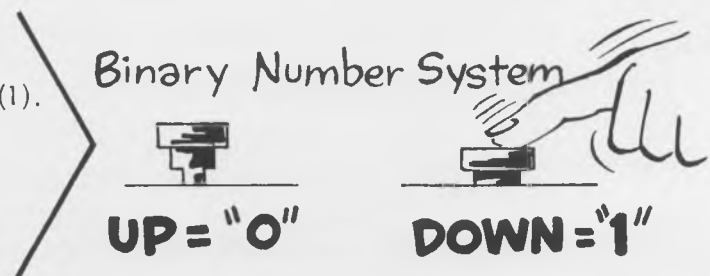

EXPERIMENT 4



SERIES CIRCUIT

This experiment demonstrates the use of two pushbuttons connected together in series to form a circuit where both pushbuttons must be pushed at the same time before the circuit is closed.

1) Program this circuit by making the following connections: 1+/1Y 2X/2A
1X/2Y 2B/2-

2) Turn the power switch ON and push down pushbutton 1. Watch light 2. It does NOT light because the connection from + to the light is broken by pushbutton 2.

3) Release pushbutton 1 and push down pushbutton 2. Watch light 2. It still does NOT light because the connection from + to the light is now broken by pushbutton 1.

4) Push down both pushbutton 1 and pushbutton 2 at the same time and see light 2 go ON. A complete circuit is now made through both pushbuttons.

5) It is possible to connect more than two pushbuttons in series and make a circuit where all the pushbuttons connected must be pushed down before the circuit is completed. Construct a series circuit using three or more pushbuttons by yourself, to demonstrate this principle. The circuit, with terminal numbers indicated, should first be drawn on paper. The circuit should then be connected on the computer using programming wires.

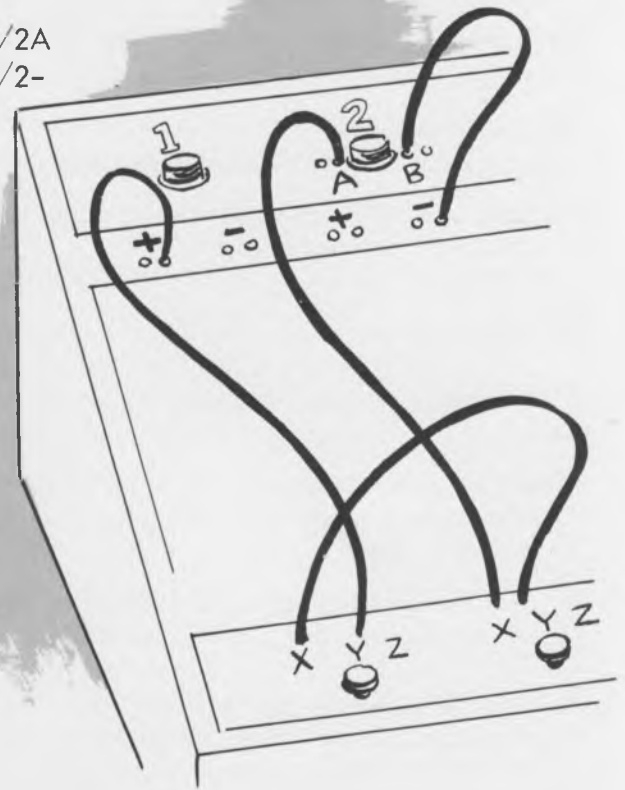

The circuit diagram looks like this:

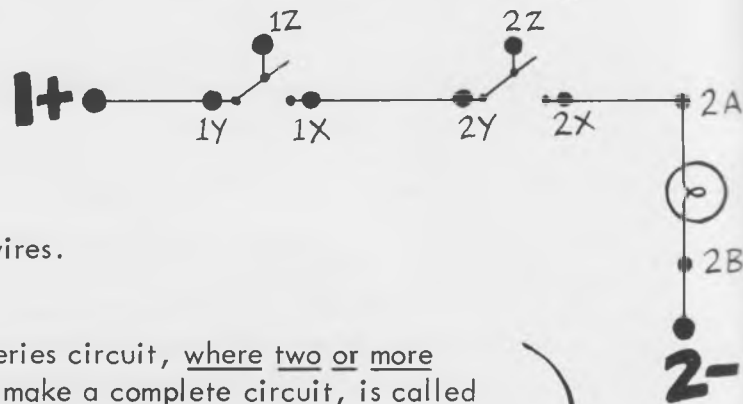

AN "AND" CIRCUIT -- The series circuit, where two or more pushbuttons must ALL be closed to make a complete circuit, is called an AND circuit, because both pushbutton 1 AND pushbutton 2 must be closed before the circuit is complete. This is a basic circuit of computer logic which will be used later.

EXPERIMENT 5

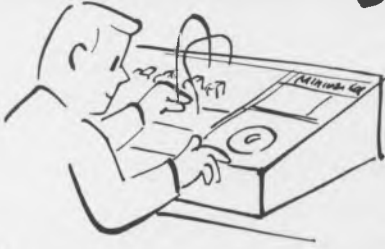

PARALLEL CIRCUIT

This experiment demonstrates the use of two pushbuttons connected together in parallel to form a circuit where either pushbutton may be pushed to complete the circuit.

1) Program this circuit by making the following connections:

1+/1Y	1Y/2Y
1X/1A	2X/1X
1B/1-	

2) Turn the power switch ON. The light does not come on because there is not a closed circuit.

3) Push down pushbutton 1. Light 1 comes ON because a closed circuit from + through the light to - is now made through the normally open contact (1X) of pushbutton 1.

4) Release pushbutton 1 and push down pushbutton 2. The light again comes ON because a closed circuit is now made through the normally open contact (2X) of pushbutton 2.

5) Push down both pushbutton 1 and pushbutton 2 at the same time. The circuit is closed and the light comes ON if either pushbutton 1 is down OR if pushbutton 2 is down OR if both pushbutton 1 and pushbutton 2 are down at the same time.

6) More than two pushbuttons may be connected in parallel to make a circuit where any one of the pushbuttons may be pushed down to complete the circuit. To demonstrate this principle, construct a parallel circuit using three or more pushbuttons. Draw the circuit diagram, and then connect the circuit on the computer using the programming wires.

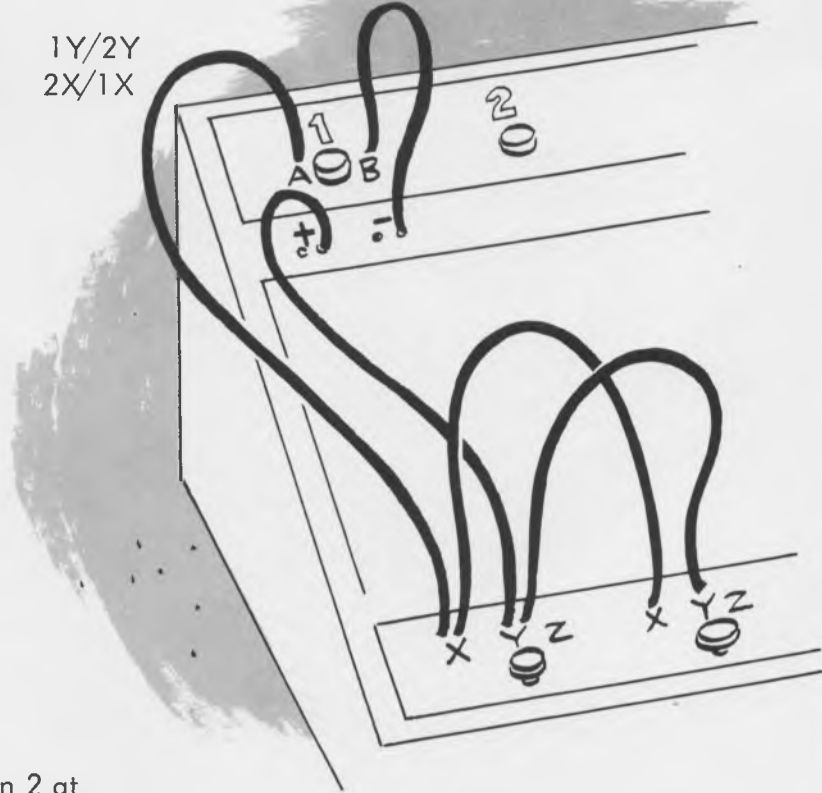

The circuit diagram looks like this:

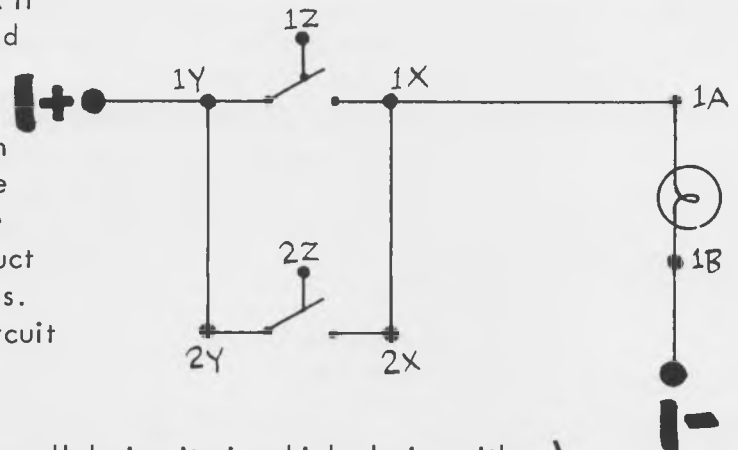

(AN "OR" CIRCUIT -- The parallel circuit, in which closing either of two or more contacts completes the circuit, is called an OR circuit. Pushing down either pushbutton 1 OR pushbutton 2 completes the circuit. This circuit is basic to much of the computer logic which is used later.)

5 RELAYS

Six identical relays labeled "storage-processing" are used by MINIVAC 601 to store or "remember" and to process computer information. Each relay has two sets of contacts, similar to the pushbutton contacts, which open and close together. The relays are operated by an electric current which flows through the relay coil, whereas the pushbuttons are manually operated.

The relay is particularly useful because it can be connected so it will "remember" whether it is ON or OFF. Every computer has some device which is able to "remember." In MINIVAC 601 this device is the relay. The relays may be used to control any of the components used in MINIVAC 601.

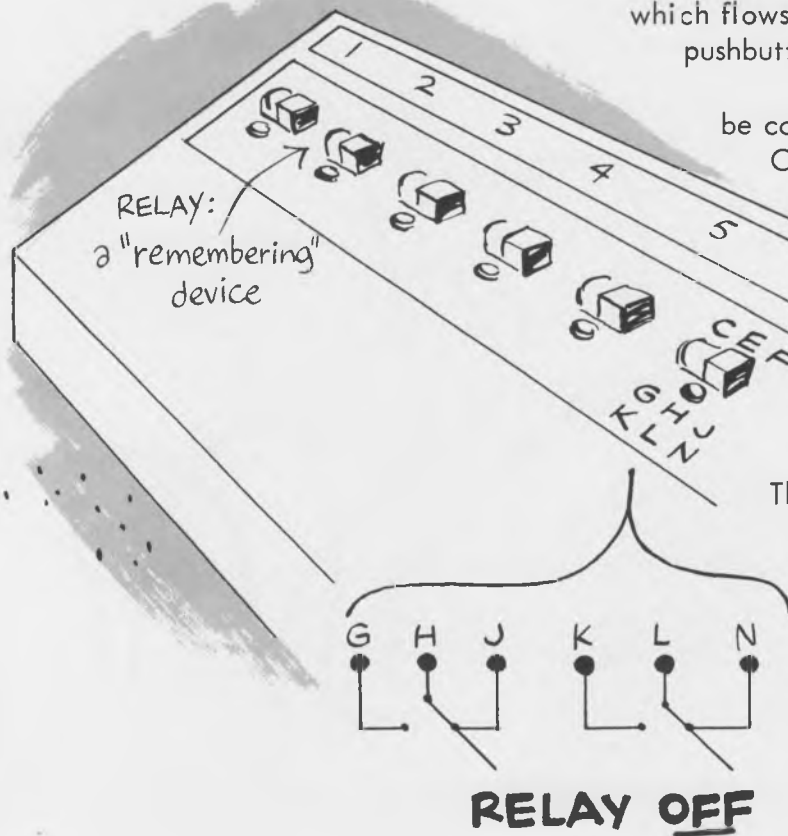

Each of the six relays has six terminals located directly below it on the computer panel. These terminals are connected under the computer panel to contacts of the relay switch. The terminals are labeled: G, H, J, & K, L, N.

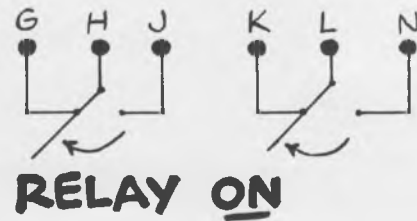

When the relay is OFF, separate electrical connections are made between terminals H and J and terminals L and N. When the relay is ON, separate electrical connections are made between terminals H and G and terminals L and K.

When relay contacts are shown in a circuit diagram, the contacts are ALWAYS shown with the relay OFF. Notice that terminals H and G and terminals L and K are not connected when the relay is OFF. Also, terminals H and J and terminals L and N are not connected when the relay is ON.

The MINIVAC relays are mounted on the computer panel with the contacts of the relay switch visible. The relay arm is in the middle, between the other two contacts. Terminals are connected to the contacts like this:

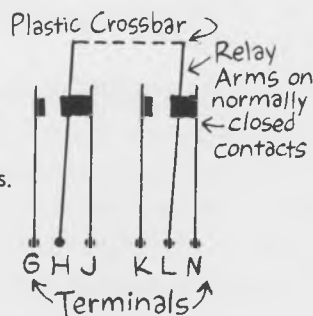

The two arms (H & L) are connected together. Both contacts always close together.

The relay switch contacts are connected to terminals in the same pattern used with the pushbutton contacts. The normally-open (N.O.) contact is connected to the left terminal, the relay arm (common contact) is connected to the center terminal, and the normally-closed (N.C.) contact is connected to the right terminal. The set of contacts closer to the operator is connected to the set of terminals closer to the operator.

The two relay arms are connected together mechanically with a plastic crossbar. Both arms move together and make or break contact at the same time. Observe the relay operation by gently pushing on the plastic crossbar with your hand. Notice how the arm leaves the normally-closed contact and swings over to touch the normally open contact.

EXPERIMENT 6

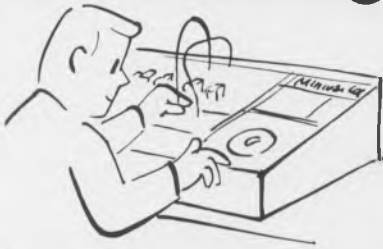

MANUAL RELAY OPERATION

This experiment uses two lights to demonstrate the basic operation of a relay switch.

1) Connect the contacts of relay 1 to turn light 2 ON when the relay is OFF, and to turn light 1 ON when the relay is ON.

2) The program for this circuit is:

1+/1H	1G/1A
1J/2A	2B/2-
1B/1-	

3) Turn power ON.
Light 2 comes ON



4) Gently push the relay crossbar to the left. Light 2 goes OFF and light 1 comes ON. Watch the relay arm alternately touch one contact and then the other as the relay crossbar is moved back and forth.

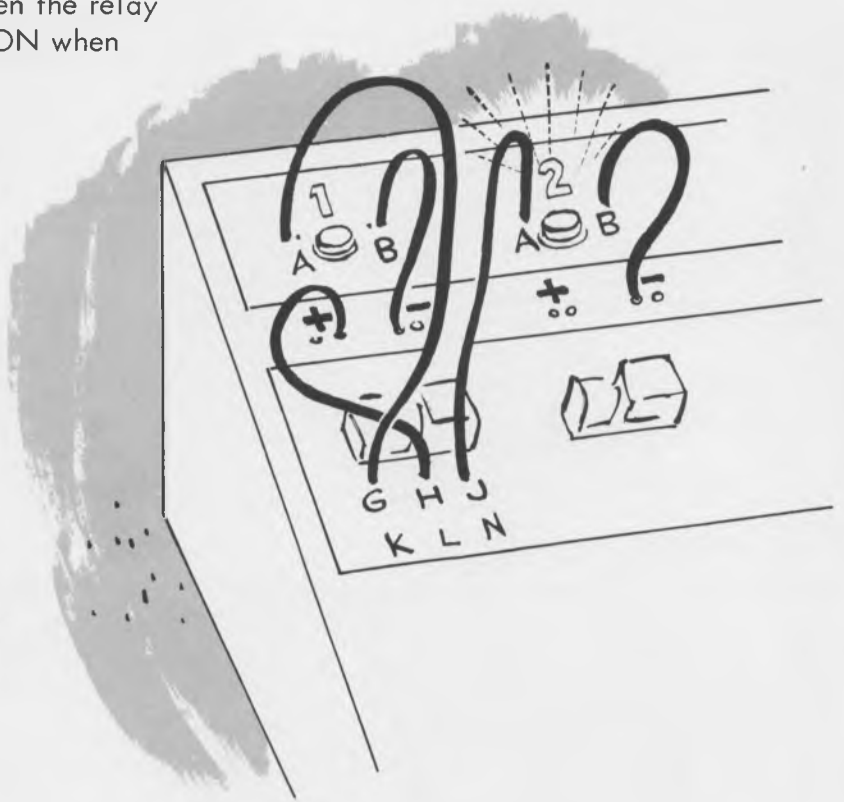

The circuit looks like this:

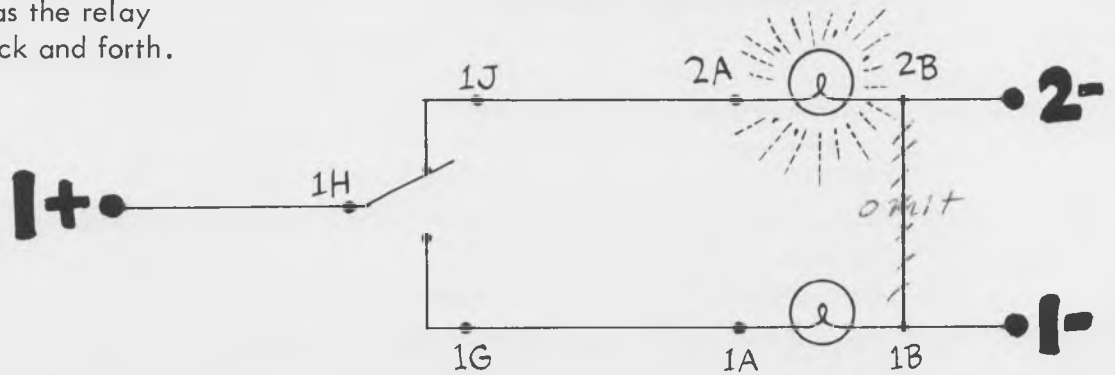

5

(cont.)

Electrical Operation of the Relay

Unlike the pushbutton which must be operated manually, the relay can be operated electrically. Each relay has a round white coil, located to the left of the arms. This is an electro-magnet which becomes magnetized when electric current flows through the coil. When the coil becomes "energized," the electro-magnet attracts the metal bar connected to the arms (by the plastic crossbar) and pulls it to the left. Sending current through the coil of the electro-magnet operates the relays.

Thus, the relay may be operated electrically without touching it physically, but the pushbutton must be operated manually.

The relay is turned ON by connecting the relay coil in a closed electric circuit. When the circuit is closed current flows through the coil and the coil is "energized."

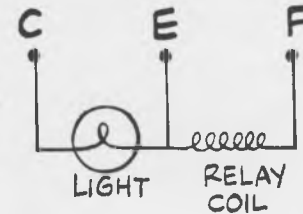
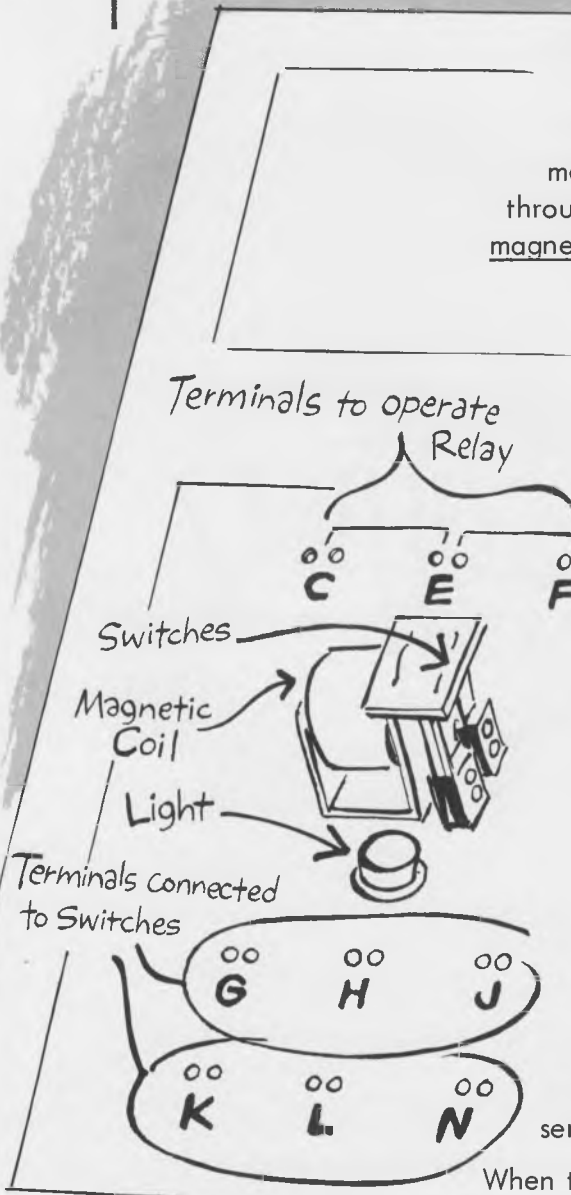

Three terminals are located directly above each relay on the computer panel. These terminals are connected under the panel to the relay coil. Two terminals are connected directly to the relay coil, and the third terminal is connected to a light wired in series with the relay coil as shown.

When the relay coil is energized by connecting power to C and F, the light directly below the relay comes ON because the light is wired in series with the relay coil. If the relay coil is energized by supplying power through contacts E and F, the light beneath the relay will NOT come on because there is no current flowing through the light. The light below the relay coil may be used to show when the relay is ON.

The circuit drawing for a relay switch looks like this:

The following experiments demonstrate relay operation with pushbuttons and lights in simple computer circuits.

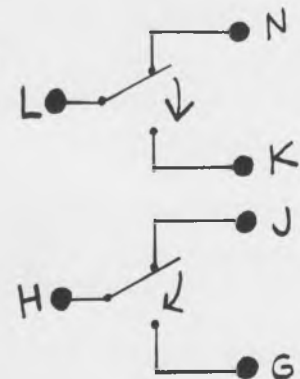

Relay Switches ALWAYS operate together

EXPERIMENT 7



ELECTRICAL RELAY OPERATION

This experiment demonstrates the basic electrical operation of a relay. Additions to the "manual relay operation" circuit of Experiment 6 permit the relay to be operated electrically through a pushbutton.

- 1) The program for connecting the switch contacts of relay 1 as shown in Experiment 6 is:

1+/1H	1G/1A
1J/2A	2B/2-
1B/1-	
- 2) The program for connecting the coil of relay 1 through the normally open contact of pushbutton 1 is:

1+/1Y	1F/1-
1X/1E	
- 3) Turn power ON. Light 2 comes ON.
- 4) Press down pushbutton 1 and see the relay operate. The relay makes a "click" as the coil is energized, and the relay contacts switch the lights. Light 2 goes OFF and light 1 comes ON. Operate the relay several times with pushbutton 1 and watch the movement of the relay contacts.
- 5) Now, connect the other set of relay contacts (1K, 1L, 1N) to two unused lights so one light comes ON when the relay is OFF and the other light comes ON when the relay is ON. Try this yourself.
- 6) To modify this program so that the coil indicator lamp will light when the coil of relay 1 is energized:

remove connection	1X/1E
add connection	1X/1C

The circuit for this modified part of the program is:

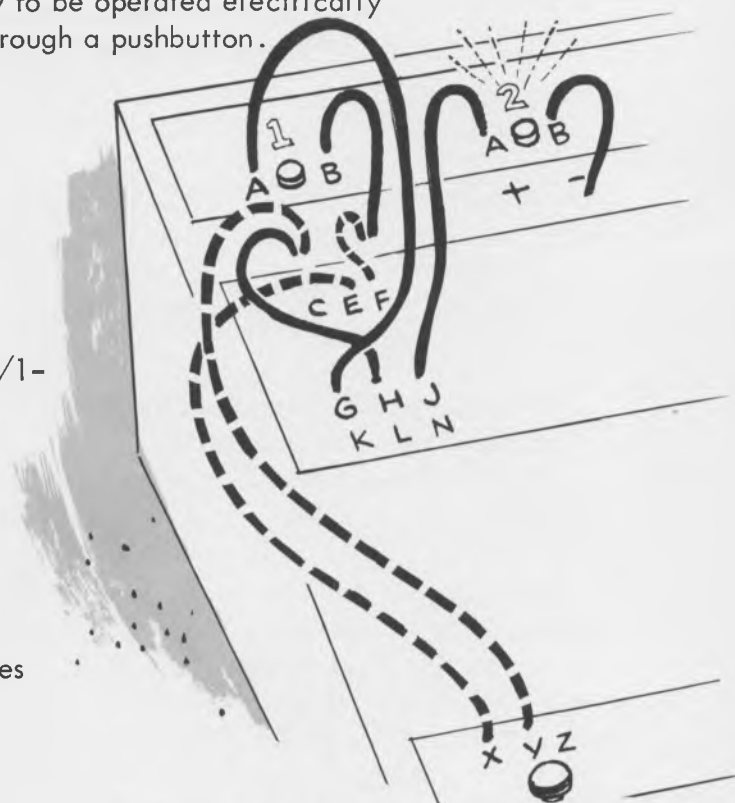
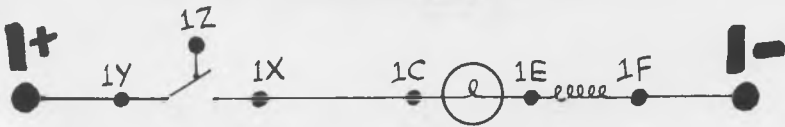

The complete circuit looks like this:

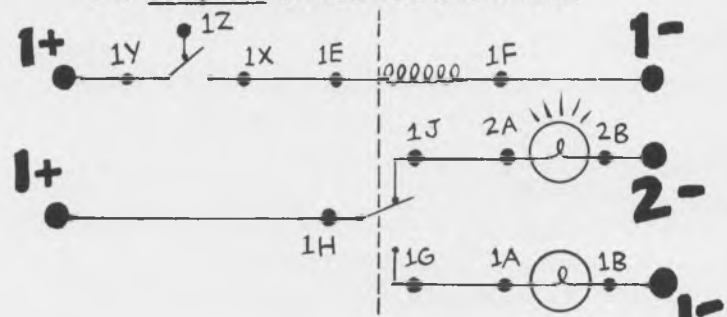

The dotted line in this circuit indicates that contacts 1G, 1H, and 1J are part of the relay switch controlled by the coil connected between 1E and 1F.

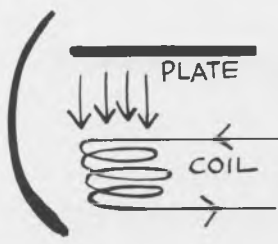

The relay is made with a small electro-magnet. When current flows through the coil, a magnetic force is produced which pulls on the small metal plate attached to the plastic crossbar to switch the contacts. In this experiment, we have seen the operation of the electro-magnet and have operated the relay to control a set of lights. We have also seen the relay indicator lamp light when the relay was turned ON.

EXPERIMENT 8



ONE RELAY CONTROLS ANOTHER

This experiment shows how a relay may be used to control another relay.

1) The program for this circuit is:

1+/1Y	1+/1H	2+/2H
1X/1C	1G/2C	2G/2A
1F/1-	2F/2-	2B/2-

2) Turn power ON and manually operate relay 2 by pushing the plastic crossbar to the left. See light 2 come ON.

3) Release relay 2 and manually operate relay 1. As you push on the plastic crossbar of relay 1, relay 2 will click ON AND LIGHT 2 WILL COME ON.
The switch contacts of relay 1 supply power to relay 2 by closing the circuit to the coil of relay 2.

4) Release relay 1 and press pushbutton 1. Relay 1 is turned ON by pushbutton 1, relay 2 is turned ON by the switch contacts of relay 1, and light 2 is turned ON by the switch contacts of relay 2. Thus, the pushbutton controls relay 2 through the contacts of relay 1.

5) It is possible to connect several relays in a series, where each relay controls another. Expand the present circuit to use all six relays with each relay controlling the coil of the next. The last relay in the series, relay 6, should turn light 6 ON.

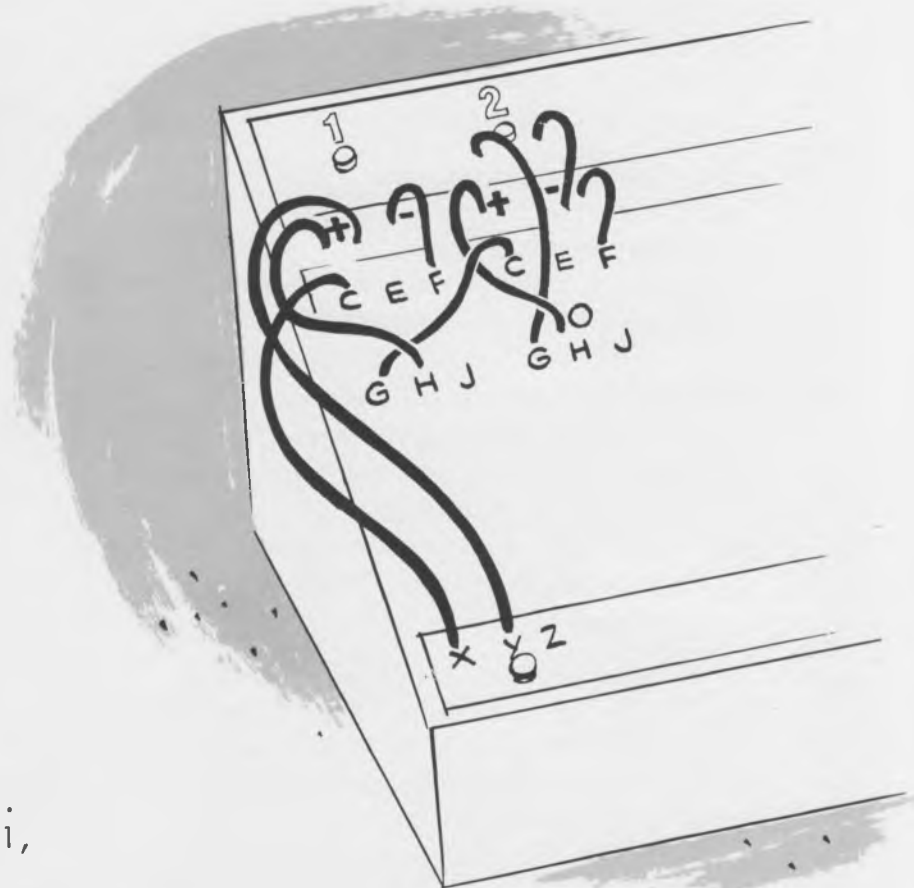

The circuit looks like this:

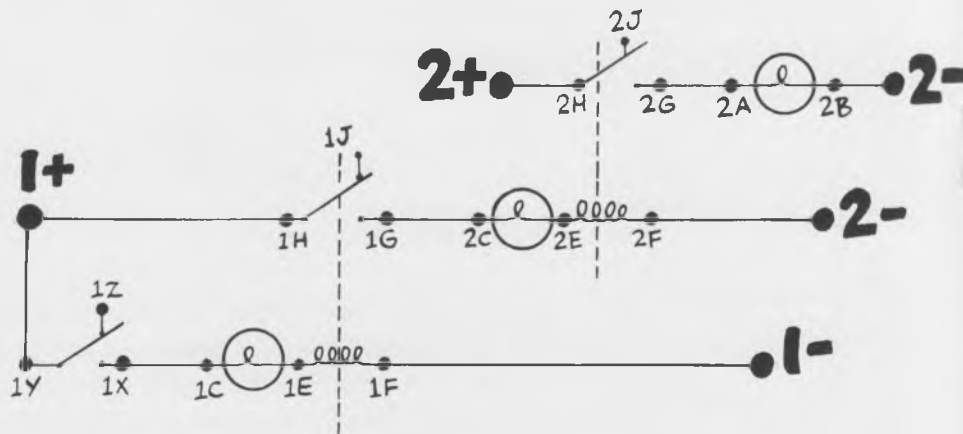

EXPERIMENT 9



A RELAY CONTROLS ITSELF

This experiment demonstrates how a relay may be used to control its own operation.

The relay is connected to remain ON when it is turned ON, and to remain OFF when it is turned OFF. The relay remains in one of the two conditions (ON or OFF) until signalled by one of the pushbuttons to change to the other condition.

- 1) The program for this circuit is:
 1F/1- 2Y/2+
 1C/1X 2Z/1L
 1Y/2Y 1K/1C
- 2) Push pushbutton 1 and release. The relay indicator light comes ON and stays ON. The relay stays ON because an electric circuit is completed through its own contacts to energize the coil.
- 3) Push pushbutton 2 and release. This momentarily interrupts current flow through the coil and turns the relay OFF. The relay indicator light turns OFF and shows that the relay is no longer energized. The relay circuit has now returned to its original condition.
- 4) Operate the circuit back and forth a few times by first pushing pushbutton 1; then pushbutton 2.

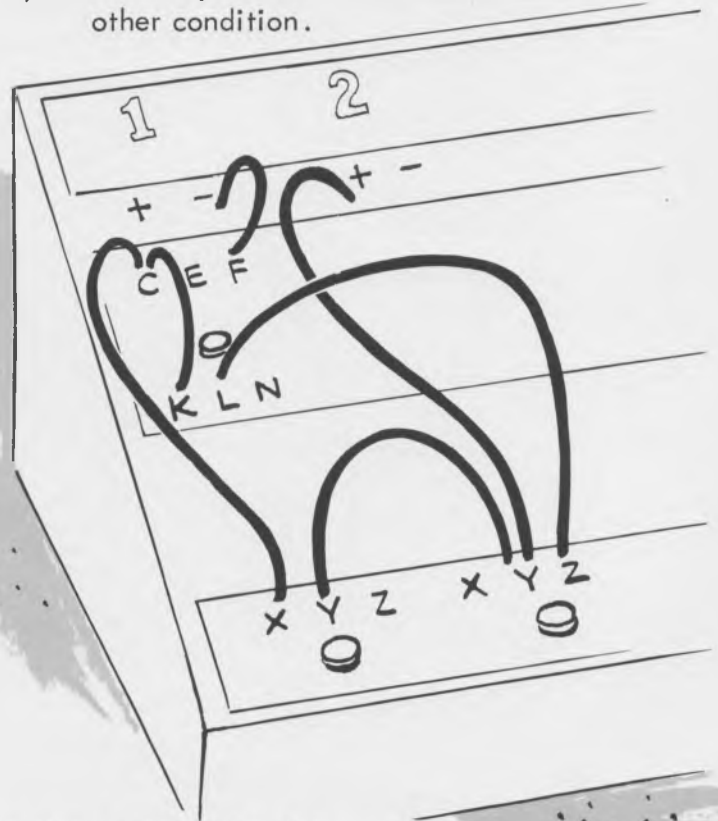

The circuit used in this experiment is called "bistable" because it is able to remain in either of two stable conditions. Many different types of "bistable" circuits are used in modern digital computers.

The circuit looks like this:

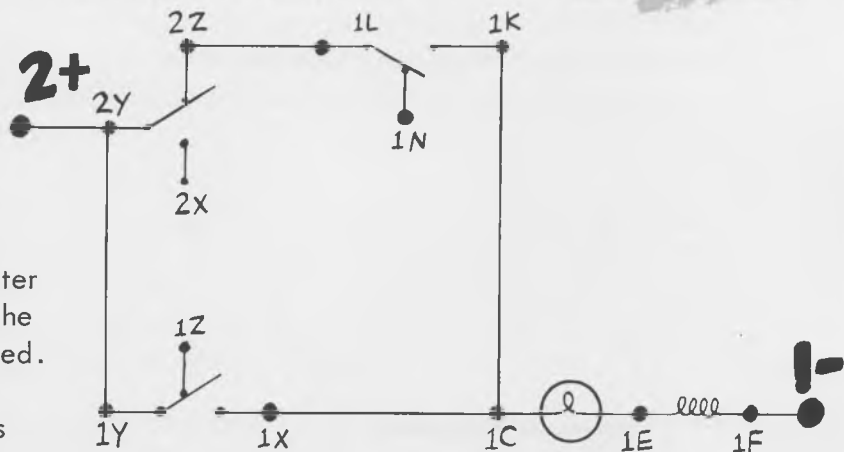

The two stable conditions of the relay circuit (ON and OFF) are used by the computer in later experiments to represent two numbers. When the relay is OFF, the number zero (0) is represented. When the relay is ON, the number one (1) is represented. The relay circuit thus remembers (stores) these binary numbers.

6 SLIDE SWITCHES

Six identical slide switches labeled "Secondary Storage" are used by MINIVAC 601 for manual storage of data and for other computer switching functions. Each switch has two sets of contacts which open and close together.

The slide switch is set to one of two positions by the computer operator, and it stays in that position until moved. The switch thus "remembers" its position and "stores" this information. The slide switch also provides a convenient means for changing circuits which are programmed on the computer, and it may be used for other computer switching functions as well.

Each of the six slide switches has six terminals located directly above it on the computer panel. These terminals are connected underneath the panel to the slide switch contacts. The terminals are labeled R, S, T, U, V, W, and are connected in the same manner for all six switches. Each switch is identified by its section number.

When the switch is pushed to the left, separate electrical connections are made between terminals S and R and between terminals V and U:

When the switch is pushed to the right, separate electrical connections are made between terminals S and T and between terminals V and W:

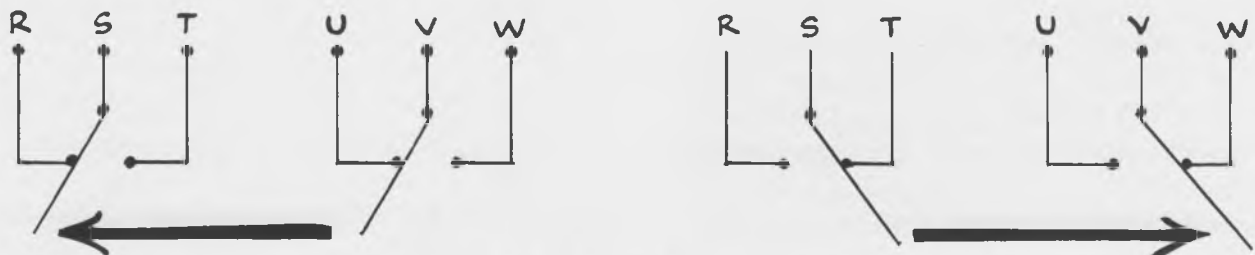

(The two sets of terminals R, S, T, and U, V, W, always work together.)

EXPERIMENT 10

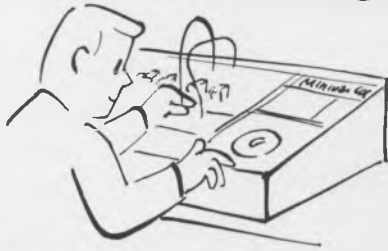

SLIDE SWITCH OPERATION

This experiment demonstrates the operation of a slide switch controlling two lights.

1) Program this circuit by making the following connections:

- 1- / 1B 2- / 2B
- 1A / 1R 2A / 1W
- 1S / 1+ 1V / 1S

2) Move switch 1 to the LEFT and turn the power ON.

3) Light 1 comes ON but light 2 remains OFF. Trace the closed circuit for light 1 and the open circuit for light 2 on the circuit diagram.

4) Move switch 1 to the right. Light 1 goes OFF and light 2 comes ON. Trace the open circuit for light 1 and the closed circuit for light 2 in the circuit diagram above by moving the switch arms from left to right.

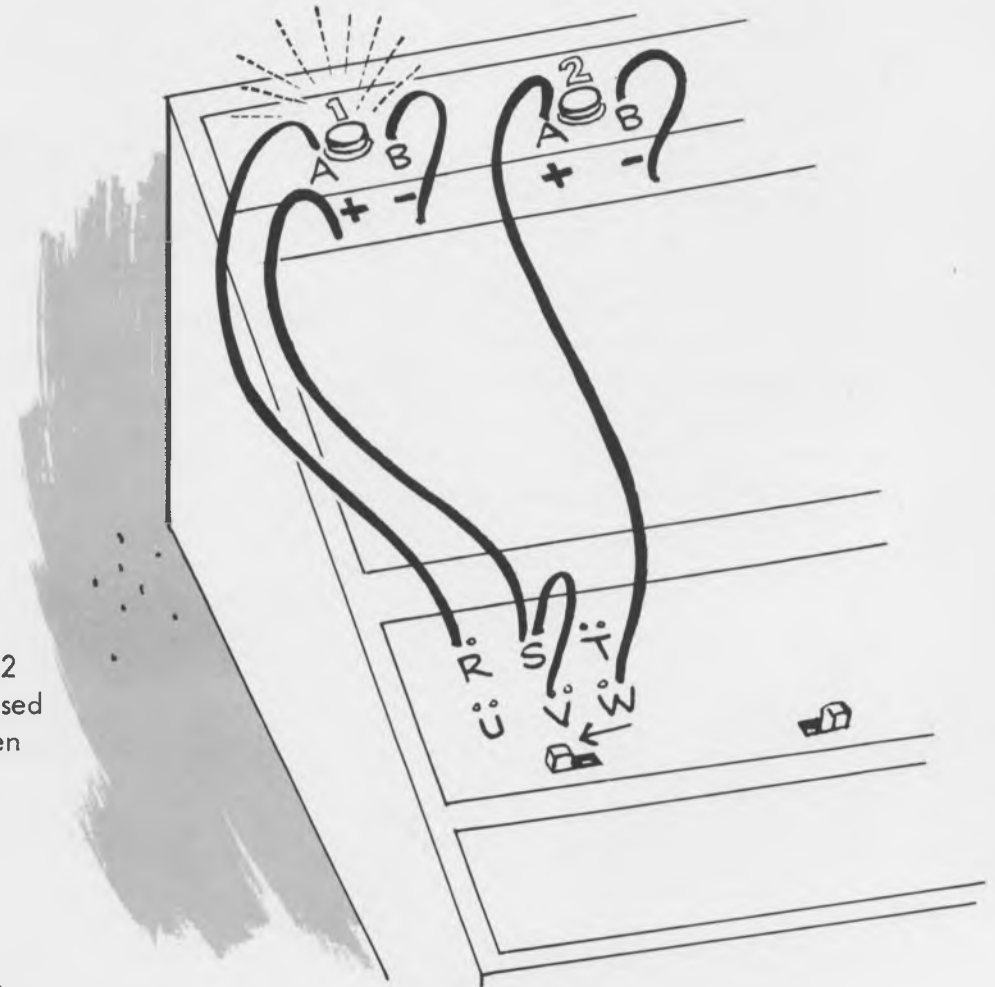

The circuit for the experiment looks like this:

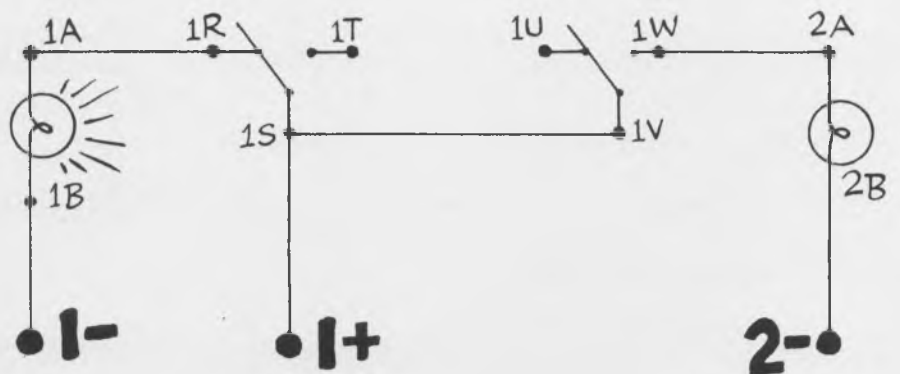

7 ROTARY SWITCH

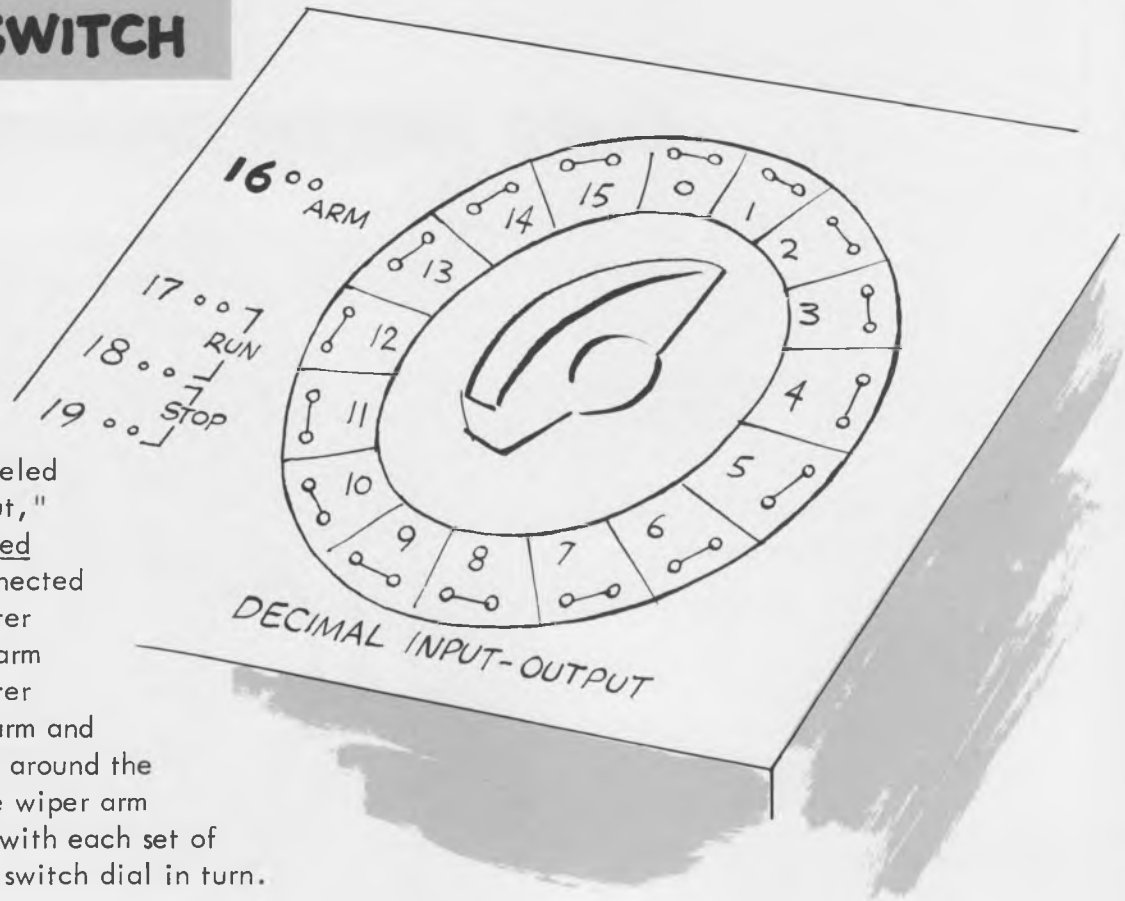

The rotary switch, labeled "Decimal Input-Output," may be manually rotated or motor driven. Connected directly with the pointer knob there is a wiper arm underneath the computer panel. As the wiper arm and the pointer knob move around the circle of contacts, the wiper arm momentarily connects with each set of contacts on the rotary switch dial in turn.

The wiper arm rotates with the pointer knob and makes an electrical connection with each set of contacts in turn around the rotary switch dial (see the following illustration). The contacts are designated by:

- D = Decimal Input-Output
- 8 = terminal number (1 to 19)
- . . . for example D8

The contact on the wiper arm is referred to as "D16."

For example, when the pointer knob points at 1, the wiper arm makes an electrical connection between D1 and D16.

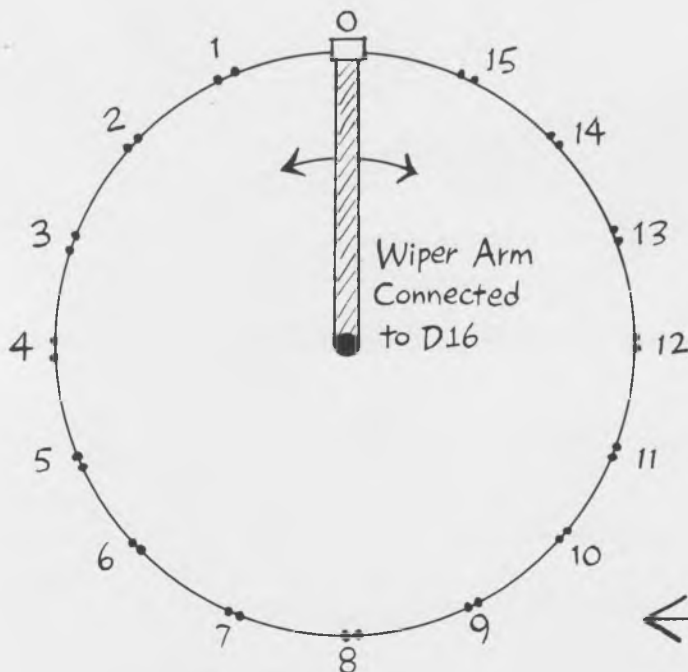

VIEW UNDER PANEL

EXPERIMENT II

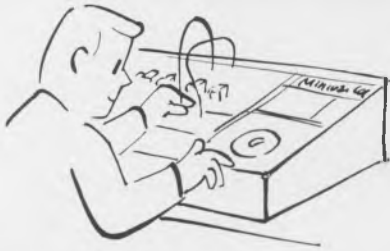

MANUAL OPERATION OF ROTARY SWITCH

This experiment demonstrates basic manual operation of the rotary switch.

Connect the rotary switch to operate lights 5 and 6 when the pointer knob points to numbers 1 and 2 respectively.

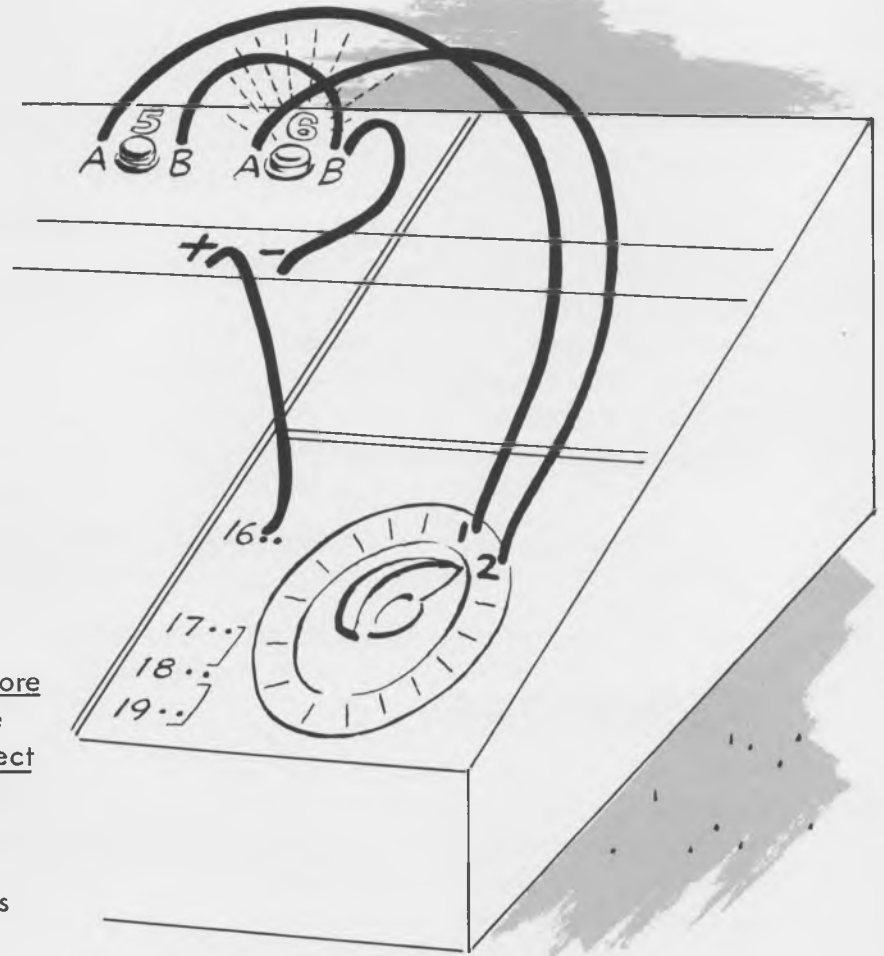

- 1) The program for this circuit is:

6+/D16	D1/5A
D2/6A	5B/6B
6-/6B	
- 2) Turn power ON and rotate the pointer to number 1. Light 5 comes ON and remains ON as long as the pointer points at number 1.
- 3) Rotate the pointer to number 2. Light 5 goes OFF and light 6 comes ON. Notice that light 5 goes OFF before light 6 comes ON. This shows that the rotary switch is designed to disconnect the arm from one contact before making connection with the next contact. The switch operation is described as "break-before-make," and thus is similar to the pushbutton switches.
- 4) Rotate the pointer knob back and forth a few times between numbers 1 and 2.
- 5) Connect several other lights to the rotary switch terminals to demonstrate that an electrical connection is made from D16 to each terminal. More than one terminal may be connected to each light. Try this yourself.
- 6) Connect the rotary switch to operate one or more relays. Control a light with each relay which is energized.

The circuit looks like this:

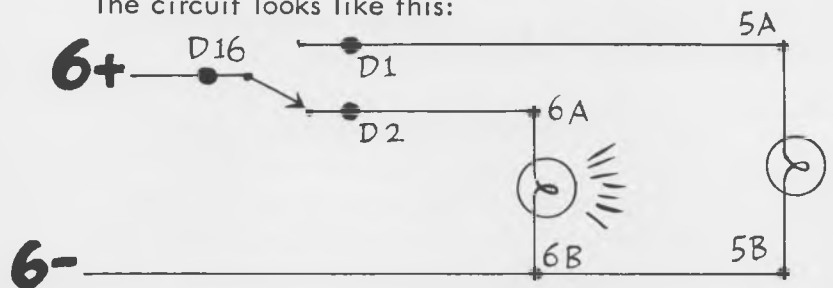

When manually operated, the rotary switch is used to send information to the computer from the operator. Thus, by positioning the pointer knob, it is possible to communicate information to the computer. The rotary switch will be used for this purpose in later experiments.

7 MOTOR DRIVE

(cont.)

The rotary switch may be positioned either by hand or by the motor drive. A DC motor turns the rotary switch through a friction drive. The rotary switch connections are made sequentially whether the pointer is turned by hand or driven by the motor.

The rotary switch motor is an electrical component which requires two connections just like a light or relay. Current must flow through the motor to make it run and turn the rotary switch. The circuit drawing of the motor looks like the above.

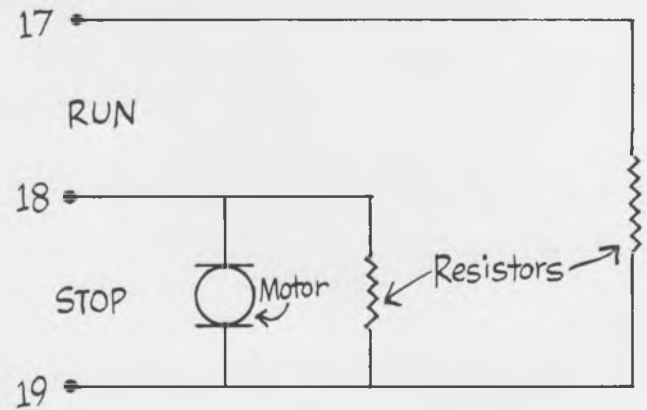

Terminals 17, 18 and 19 are located on the panel just to the left of the pointer knob and rotary switch terminals. Power must be supplied to terminals 17 and 18 (run) to operate the motor drive. A short circuit may be connected across terminals 18 and 19 (stop) to halt the motor drive.

7 RESISTORS

The electrical resistors used with the motor drive limit the current which flows through the circuit in the same way that the lights limit the amount of

current which flows through a relay coil. The resistors make it possible to connect a short circuit across the STOP terminals to stop the motor without over-loading the power supply.

7 DECIMAL INPUT-OUTPUT

The motor driven rotary switch is called a Decimal Input-Output because it has positions which are designated by ordinary decimal numbers. "Input-Output" means that the rotary switch may be used by the operator to manually deliver information to the computer or that the computer may

automatically deliver information to the operator. The Decimal Input-Output is thus used by the operator to communicate with the computer using decimal numbers.

The following experiments demonstrate the rotary switch and motor drive operation.

EXPERIMENT 12

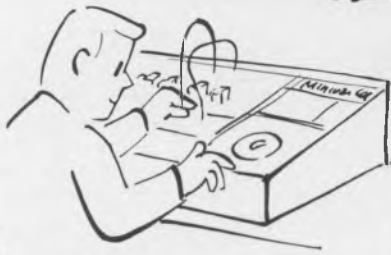

BASIC MOTOR OPERATION

This experiment demonstrates the basic motor drive operation. The circuit looks like this:

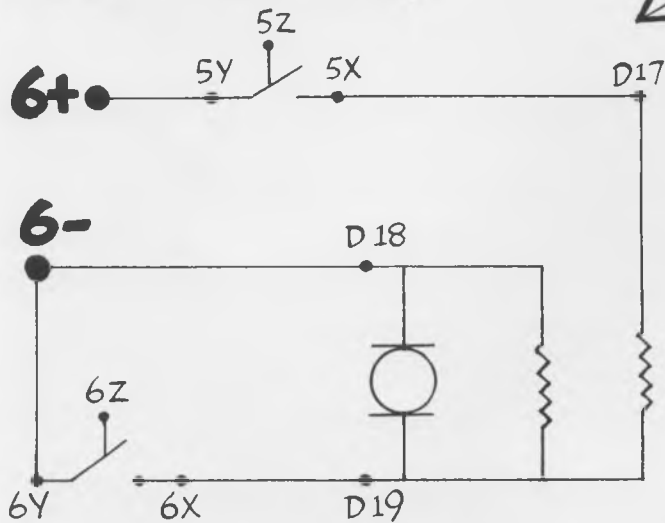

1) Connect the motor to operate with pushbutton control using the following program:

```
6+/5Y    6-/D18
5X/D17   6-/6Y
          6X/D19
```

2) Turn the power ON. Push pushbutton 5. This supplies power to the RUN terminals (D17 and D18) and causes the pointer of the rotary switch to rotate.

3) While holding pushbutton 5 down, push pushbutton 6. The motor stops when pushbutton 6 is pushed because a short circuit is created across the STOP terminals (D18 and D19). Current flows through pushbutton 6 instead of through the motor.

4) While holding pushbutton 5 down, release pushbutton 6. The motor drive operates again because the short circuit has been removed.

5) Release pushbutton 5. The motor drive again stops, this time because power is no longer connected to the motor circuit.

EXPERIMENT 13



MOTOR DRIVEN ROTARY SWITCH

This experiment demonstrates how the motor driven rotary switch may be used to generate electrical pulses for the computer and to automatically perform a series of operations in sequence.

1) Connect the motor to operate with pushbutton control using the circuit of Experiment 12.

2) Connect lights 5 and 6 to the rotary switch using the circuit of Experiment 11. The combined program from Experiments 11 and 12 is:

```
6+/D16    D1/5A    5-/D18
D2/6A     5B/6B    6-/6Y
6-/6B     6+/5Y    6X/D19
          5X/D17
```

3) Push pushbutton 5. The motor rotates the pointer knob as in Experiment 11. As the pointer knob turns, light 5 and light 6 flash ON in sequence. The rotary switch is automatically generating electrical pulses to flash the lights. First, light 5 flashes and then light 6 flashes, once each revolution of the rotary switch.

4) While holding pushbutton 5 down, push pushbutton 6. The pointer knob STOPS turning and the lights STOP flashing.

PULSE GENERATOR

The electrical pulses which are used to flash light 5 (or the pulses which flash light 6) continue as long as the motor continues to run. Pulses like these are used to automatically operate MINIVAC 601 in future experiments. Most automatic digital computers have a mechanical or electronic device, similar in function to the rotary switch, to generate a continuous series of electrical pulses. This is done to make the computer operate continuously and automatically at speeds much faster than a human could operate a switch. Continuous pulses, generated to operate a digital computer, are called "clock" pulses. The use of "clock" pulses in MINIVAC 601 and other digital computers is explained and demonstrated in future experiments.



7 PROGRAMMER

As the motor turns the rotary switch light 5, and then light 6, flashes. This occurs in the same order (sequence), once each revolution of the switch. Other lights could be flashed, or relays could be energized, in any desired sequence by using other rotary switch terminals. Thus, it is possible to use the rotary switch to carry out a whole series of operations on the computer. The particular connections which are made to accomplish a series of computer operations are called a "program." All digital computers, including MINIVAC 601 must be "programmed" to solve a specific problem. The use of the rotary switch for "programming" is explained and demonstrated in future experiments.

EXPERIMENT 14

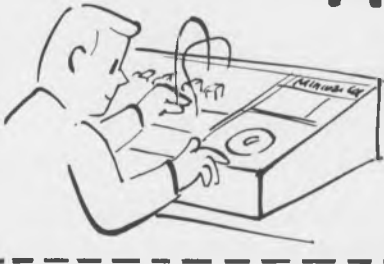

MOTOR REVERSING

This experiment shows how the direction of rotation of the motor may be changed by reversing the direction of current flow through the motor.

1) Connect power to the rotary switch motor through two sets of slide switch contacts so that the direction of current flow through the motor may be reversed through the switch. The circuit looks like this:

2) The program for this circuit is:
 6+/6R 6T/6U 6V/D17
 6+/6W 6S/D18
 6-/6T

3) Trace the direction of current flow from 6+ through the motor to 6- with the switch in the right position and then again with the switch in the left position. The current flow through the motor is reversed when the switch position is changed.

4) Turn power ON and notice the direction of rotation.

5) Change the position of switch 6. The motor reverses direction and the pointer knob turns in the opposite direction.

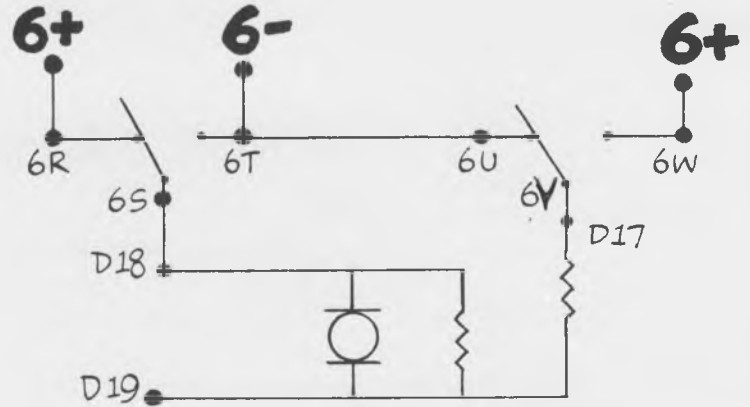

(The ability of the motor to reverse direction greatly increases the value of the rotary switch as a programmer. Many future experiments make use of the basic fact that the direction of rotation may be reversed by reversing the current flow through the motor.)

8 MATRIX

The matrix provides convenient junction points for use when the computer plays games or recognizes symbols.

The matrix consists of a number of terminals, located in the upper right corner of the computer panel. The terminals are used as junction points, and there are no connections to the terminals below the panel.

The matrix terminals are designated by:

M = matrix

6 = terminal number (1 to 11)

t = top or "b" for bottom

... for example M6t

The lines between the terminals indicate terminals which are connected together to form a single contact.



The matrix terminals are arranged in a convenient pattern for playing games like tic-tac-toe or solving character recognition problems. When the computer is programmed to play tic-tac-toe, the various plays are recorded by making connections on the matrix terminals. When the computer is programmed to recognize characters, the characters are formed by making connections on the matrix. Games and character recognition problems are presented in other books in this series.

9 AUXILIARY TERMINALS

Auxiliary terminals are provided between the slide switches and the relays for each of the six sections.

The terminals with four holes labeled COMMON may be used when more than two connections must be made to a set of terminals on the computer panel. The four COMMON terminals are connected together, but are not connected to any other component.

The terminals marked "CAPACITOR" are used when auxiliary components are added to the MINIVAC 601 in advanced programs. At present these terminals may be ignored.

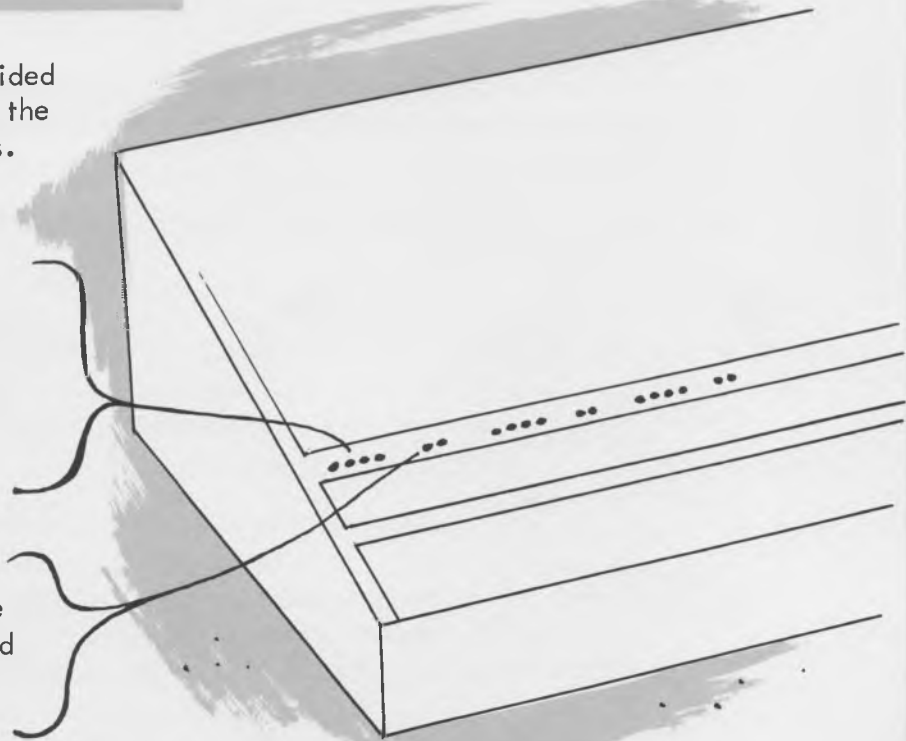

10 Looking Ahead with MINIVAC 601

Book I -- "Getting Acquainted with MINIVAC 601" -- has examined the operation of each MINIVAC 601 component. The symbols and shorthand of circuit drawings have been introduced and basic computer programs were developed in the experiments.

Now that you are completely familiar with the components of MINIVAC 601, you are ready to explore the exciting world of digital computers.

THERE ARE SIX BOOKS IN THE MINIVAC SERIES. THE OTHER FIVE ARE:



Book II answers the question WHAT IS A DIGITAL COMPUTER ? and introduces large scale electronic data processing machines. You will discover how a digital computer:

- Accepts input information representing basic data to be processed and instructions describing the calculation to be performed.
- Stores (remembers) input and other information which it generates.
- Processes information and controls its operation, making logical decisions and performing arithmetic.
- Generates output information representing answers to a problem.

The components generally used in modern digital computing equipment are discussed and their operation is compared with the operation of analogous components in MINIVAC 601.

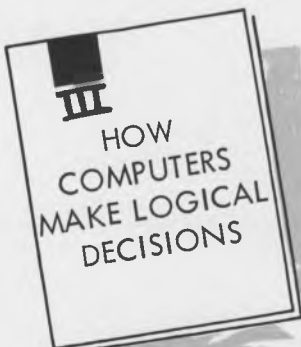

Book III provides an introduction to computer logic and uses MINIVAC 601 to demonstrate basic rules of logic. The four fundamental logical operations--AND, OR, NOT, EITHER BUT NOT BOTH--are described and these operations are simulated with computer circuits.

The principles of Boolean Algebra are presented to provide a basis for the solution of complex logical problems on MINIVAC 601. A series of experiments and problems provides practical experience in converting logical problems to circuit diagrams. Circuit diagrams are programmed on MINIVAC 601 and logical problems and riddles are actually solved on the computer.

A digital computer performs addition, subtraction, multiplication, division, and other more complex calculations in an arithmetic unit. Some computers use DECIMAL numbers, but most high-speed digital machines do arithmetic with BINARY numbers. Arithmetic is generally done with simple addition or subtraction using either the "serial" or "parallel" method. Complex calculations are made by doing a series of additions or subtractions.

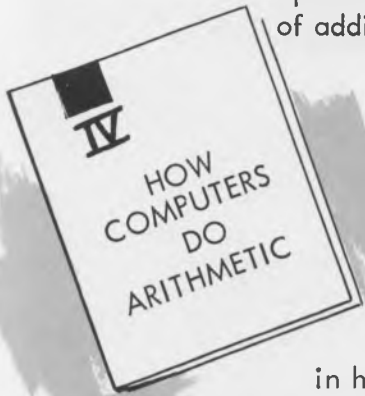

Book IV examines the Decimal Number System and from this derives rules for forming any number system. These rules are applied to the derivation of the Binary Number System. The Relationships and rules for converting between Binary and Decimal Numbers are discussed.

After the introduction to the number system generally used in high-speed digital machines, the Binary Arithmetic Operations are explained and demonstrated with appropriate programs for MINIVAC 601.



Book V uses MINIVAC 601 to demonstrate how computer functions may be combined to perform specific jobs. Examples of computer applications are examined under five major headings:

- "Simple Computer-like Devices Encountered Every Day"
- "Computer Applications in Business and Industry"
- "Computer Applications in Science and the Military"
- "Computer Applications in the Social Sciences"
- "Computer Applications in Science Fiction Films"

Book V also discusses how computers "read" printed material and understand "computer languages."



Book VI contains games which may be played using MINIVAC 601 as an opponent, partner or referee. These games are designed for fun with MINIVAC 601, but they also demonstrate important functions of modern high-speed computers and provide examples of special kinds of problem solving.

The following problems are presented to give you an opportunity to work out computer programs on your MINIVAC 601. When attacking a problem, it is often helpful to follow a step-by-step procedure:

- a) Draw a schematic representation of the components you think will be used.
- b) Draw connections between the components to solve the first part of the problem.
- c) Continue with each part of the problem in turn, adding or changing connections to meet the new requirements.
- d) From your completed drawing, program the solution on your MINIVAC 601.

PROBLEMS 1 THROUGH 6 USE PUSHBUTTONS, LIGHTS

1) Design a circuit in which light 1 comes ON when pushbutton 1 is pushed and light 2 comes ON when pushbutton 2 is pushed, and both come ON at the same time if both pushbuttons are pushed.

2) Design a circuit in which light 1 comes ON if either pushbutton 1 or pushbutton 2 is pushed, but light 1 is OFF if both pushbutton 1 and pushbutton 2 are pushed together.

3) Design a circuit with 2 pushbuttons and a light in which all of the conditions indicated in the table below occur:

Pushbutton 1	Pushbutton 2	Light 1
Up	Up	On
Down	Up	Off
Up	Down	Off
Down	Down	On

4) Design a circuit with 2 pushbuttons and 2 lights in which all of the conditions indicated in the table below occur:

Pushbutton 1	Pushbutton 2	Light 1	Light 2
Up	Up	Off	Off
Down	Up	Off	On
Up	Down	On	Off
Down	Down	Off	On

5) Design an OR (parallel) circuit in which light 1 comes ON if either pushbutton 1 is down, or if slide switch 1 is in the left position, or if pushbutton 2 is down.

6) Design an AND (series) circuit in which light 1 comes ON if and only if, pushbutton 1 is down and slide switch 1 is left and pushbutton 2 is down and slide switch 2 is right.

PROBLEMS 7 THROUGH 12 USE RELAYS

7) Design a circuit in which light 1 comes ON when pushbutton 1 is pushed, and relay 1 comes ON when pushbutton 2 is pushed. Relay 1 should come ON only if light 1 is ON.

8) Design a circuit in which light 1 and relay 2 are ON if slide switch 1 is left, and light 2 and relay 1 are ON if slide switch 1 is right. Use separate contacts to control each component.

9) Design a circuit in which relay 1 comes ON and remains ON when pushbutton 1 is pushed and released. Relay 1 goes OFF and remains OFF when pushbutton 2 is pushed and released. Terminal 2Z may not be used

for this problem. (Refer back to the relay experiments if you have trouble with this problem.)

10) Design a circuit in which relay 1 comes ON when pushbutton 1 is pushed if slide switch 1 is left; and relay 2 comes ON when pushbutton 1 is pushed if slide switch 1 is right.

11) Design an AND (series) circuit in which light 1 comes ON if and only if, slide switch 1 is left and slide switch 2 is right and relay 1 is ON, and relay 2 is OFF. Control relay 1 with pushbutton 1 and relay 2 with pushbutton 2.

12) Design an OR (parallel) circuit in which light 2 comes ON if either slide switch 1 is right, or slide switch 2 is left, or relay 1 is OFF, or relay 2 is ON. Control relay 1 with pushbutton 1 and relay 2 with pushbutton 2.

PROBLEMS 13 THROUGH 19 USE THE ROTARY SWITCH

13) Design a circuit in which the rotary switch turns and light 6 comes ON when pushbutton 6 is pushed.

14) Design a circuit in which the rotary switch turns only when pushbutton 6 is down. The rotary switch should NOT turn when pushbutton 6 is up, or when both pushbutton 6 and pushbutton 5 are down.

15) Design a circuit to meet the requirements of problem 14 using terminal 5X.

16) Design a circuit in which the rotary switch turns when pushbutton 6 is pushed but turns in the opposite direction when pushbutton 5 is pushed. The rotary switch should not turn if no pushbuttons are down, or if both pushbuttons are down.

17) Design a circuit to automatically turn the rotary switch back and forth between numbers 1 and 6. Use only 11 programming wires.

18) Design a circuit to turn the rotary switch when pushbutton 6 is down, and to automatically stop the rotary switch when it reaches DO. The rotary switch should start again and make another revolution when pushbutton 5 is pushed and then released.

19) Design a circuit to automatically flash lights 1 through 6 in sequence when pushbutton 6 is pushed.

20) (MORE DIFFICULT) Design a circuit to alternately turn relay 1 ON and OFF as pushbutton 1 is pushed momentarily and released. Relay 1 should come ON the first time pushbutton 1 is pushed and it should go OFF the second time the pushbutton is pushed. The rotary switch is not used for this problem.

ANSWER 1

1+/1Y	2+/2Y
1X/1A	2X/2A
1B/1-	2B/2-

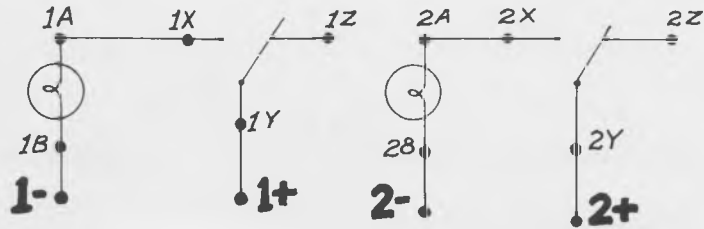

ANSWER 2

1+/1Y	2Y/1A
1Z/2X	1B/1-
1X/2Z	

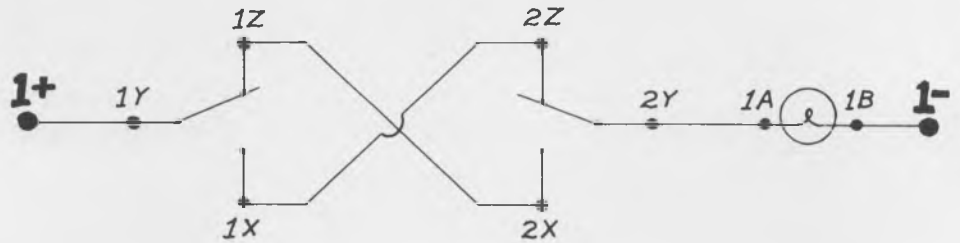

ANSWER 3

1+/1Y	1Z/2Z
1X/2X	2Y/1A
	1B/1-

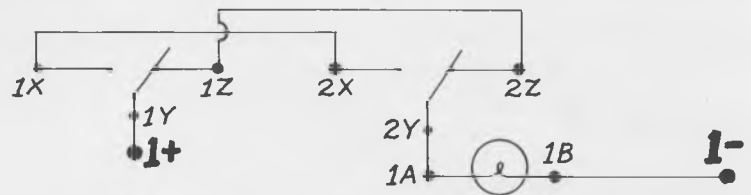

ANSWER 4

1+/1Y	1Z/2X
1X/2A	2Y/1A
2B/2-	1B/1-

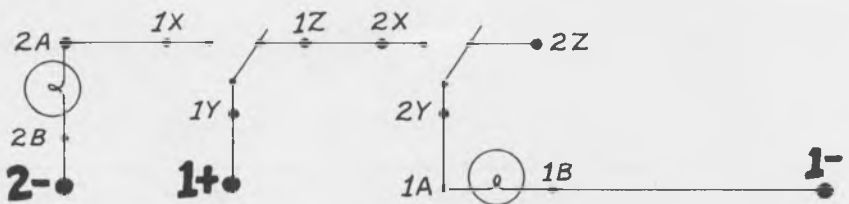

ANSWER 5

1+/1S	1X/1R
1S/1Y	1R/1A
1Y/2Y	1B/1-
2X/1X	

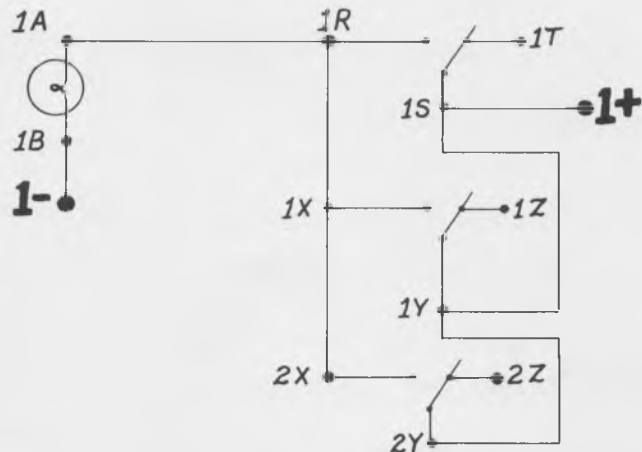

ANSWER 6

1+/1Y	2X/2T
1X/1R	2S/1A
1S/2Y	1-/1B

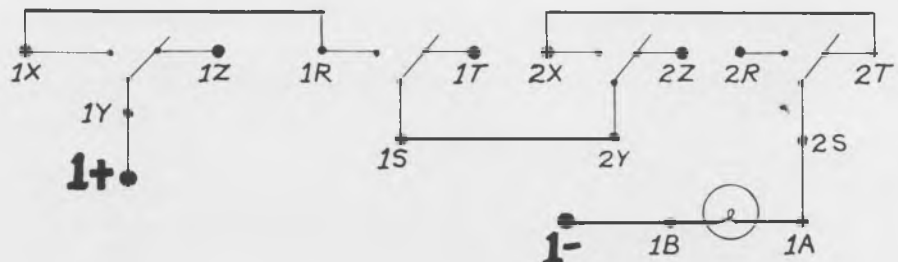

ANSWER 7

- 1-/1B
- 1A/1X
- 1+/1Y
- 1X/2X
- 2Y/1C
- 1F/2-

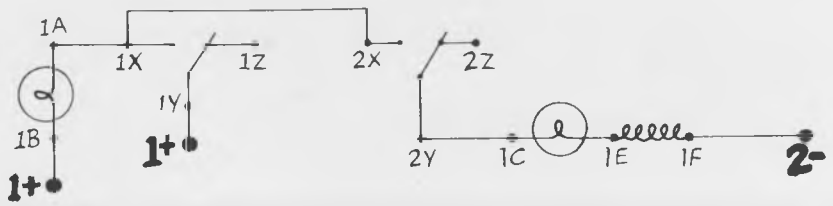

ANSWER 8

- 1-/1B
- 1A/1R
- 1+/1S
- 1S/1V
- 1W/1C
- 1F/1-
- 2-/2B
- 2A/1T
- 2-/2F
- 2C/1U

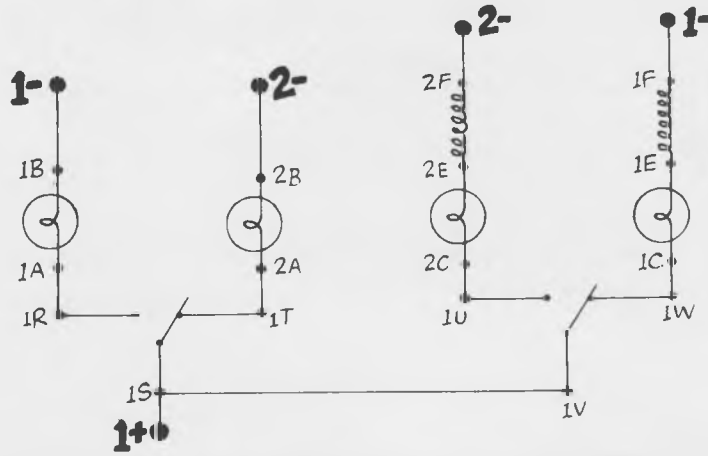

ANSWER 9

- 1+/1G
- 1G/1X
- 1Y/1H
- 1H/1C
- 1F/1-
- 1F/2Y
- 1E/2X
- 2Z (not used)

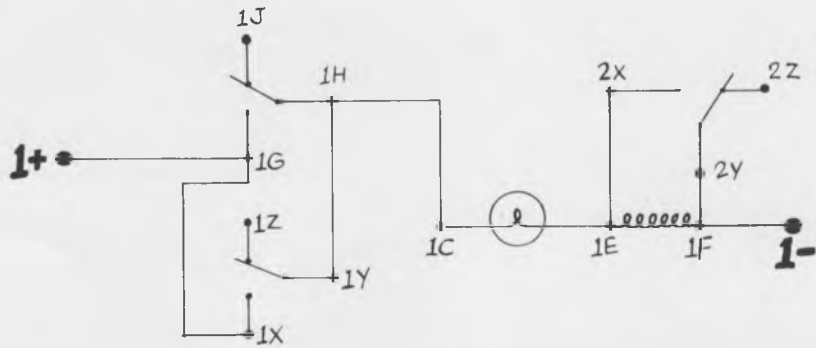

ANSWER 10

- 1+/1Y
- 1X/1S
- 1R/1C
- 1T/2C
- 1F/1-
- 2F/2-

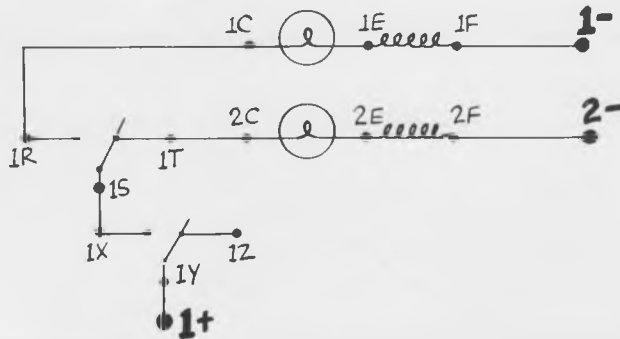

ANSWER 11

- 1+/1H
- 1H/1Y
- 1Y/2Y
- 1X/1C
- 1F/1-
- 2X/2C
- 2F/2-
- 1G/1R
- 1S/2S
- 2T/2J
- 2H/1A
- 1B/2-

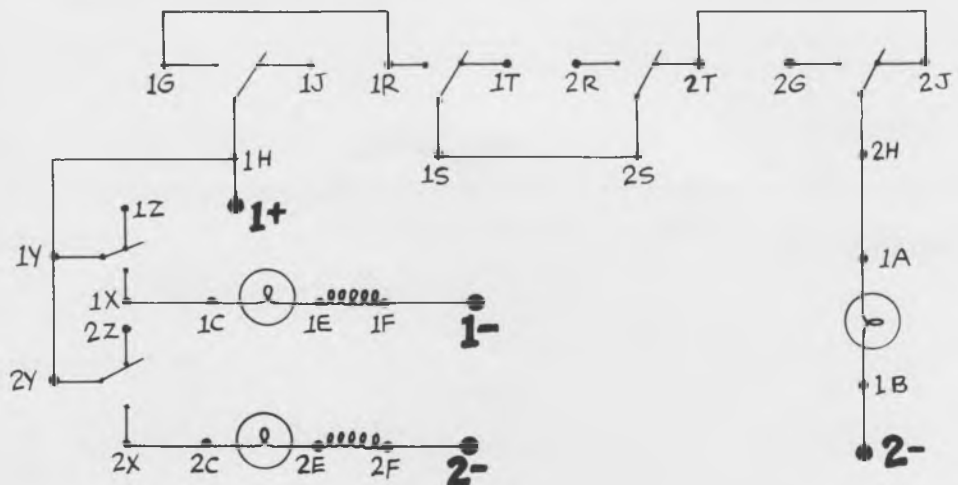

ANSWER 12

2-/2B
2A/1T
1T/2R
2R/1J
1J/2G
1+/1S
1S/2S
2S/1H
1H/2H

2+/2Y
2Y/1Y
1X/1C
1F/1-
2X/2C
2F/2-

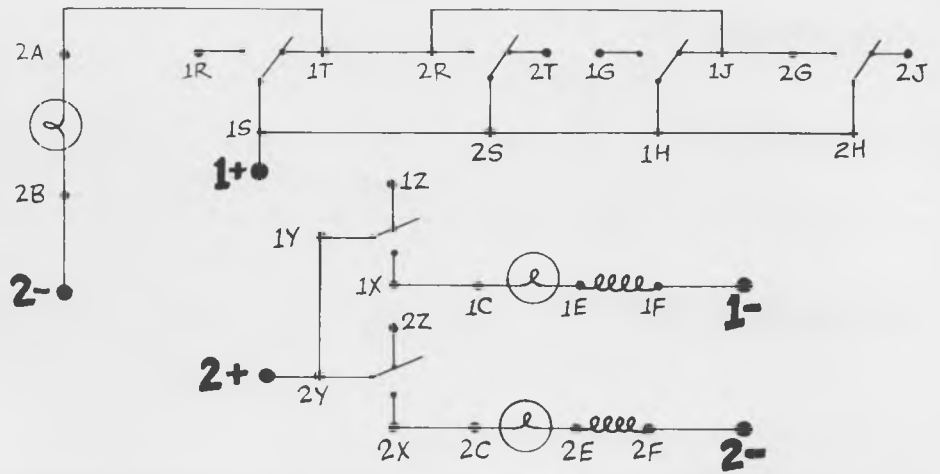

ANSWER 13

6+/6Y
6X/6A
6B/6-
6X/D17
D18/M-

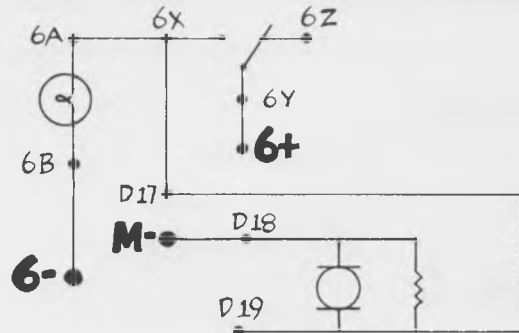

ANSWER 14

5+/5Y
5Z/6X
6Y/D17
M-/D18

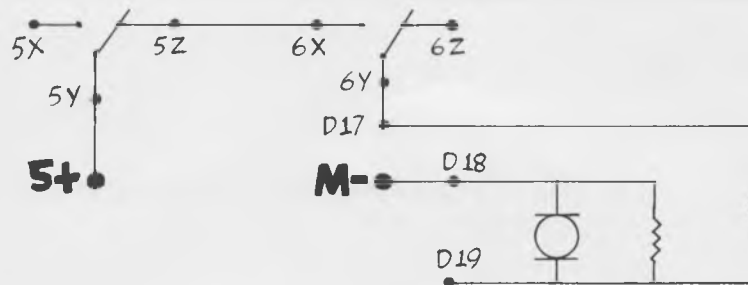

ANSWER 15

6+/6X
6Y/D17
M-/D18
D18/5X
5Y/D19

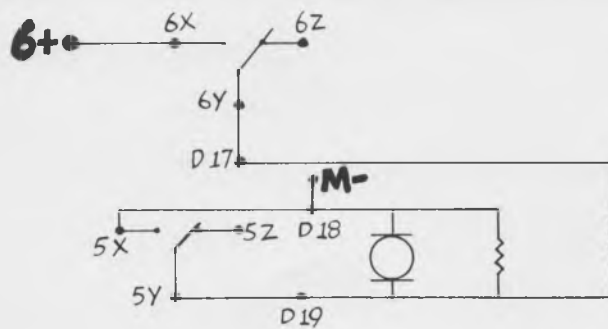

ANSWER 16

5+/5Y
5Z/6X
6Y/6J
6Z/5X
6Z/6C
6F/6-
6J/6K
6-/6G
6G/6N
6L/D18
6H/D17

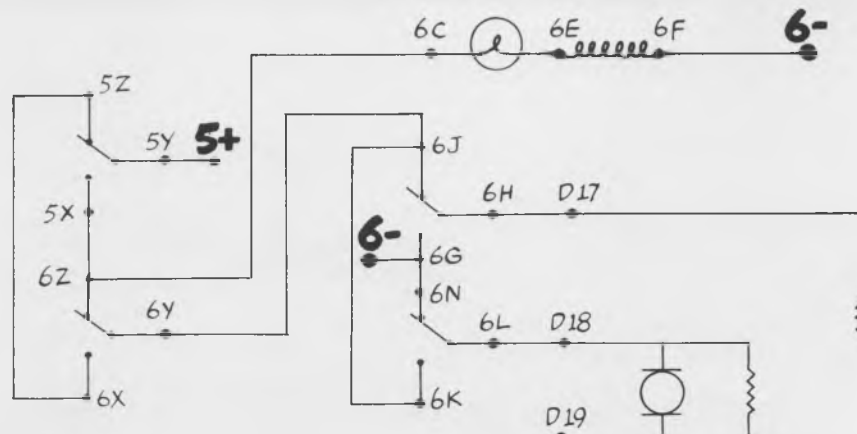

ANSWER 17

6+/6J	6C/6L
6J/6K	6L/D18
6K/D6	6H/D17
6E/D16	6-/6N
6F/6-	6N/6G
6G/D1	

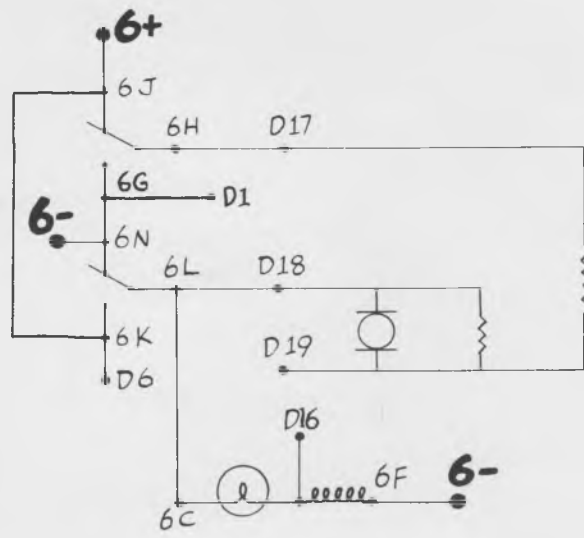

ANSWER 18

6+/6Y
6X/D17
M-/D18
5Z/D18
5Y/D0
D16/D19

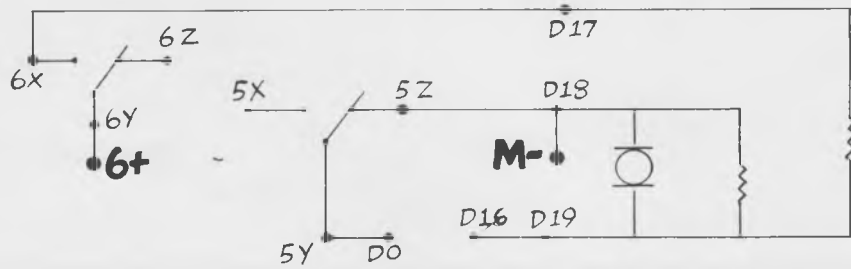

ANSWER 19

D1/1A	6+/6Y
D2/2A	6X/D17
D3/3A	M-/D18
D4/4A	M+/D16
D5/5A	
D6/6A	
1B/1-	
2B/2-	
3B/3-	
4B/4-	
5B/5-	
6B/6-	

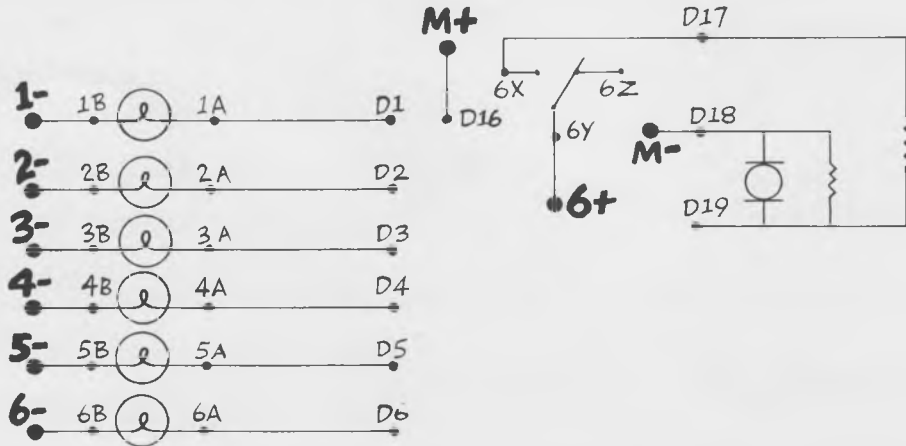

ANSWER 20

1-/1B	1Y/1+
1-/1C	1X/1J
1A/1E	1J/2H
1E/2G	2J/2E
1F/2F	2E/2A
1H/1F	2B/2-
1G/1Y	2-/2C

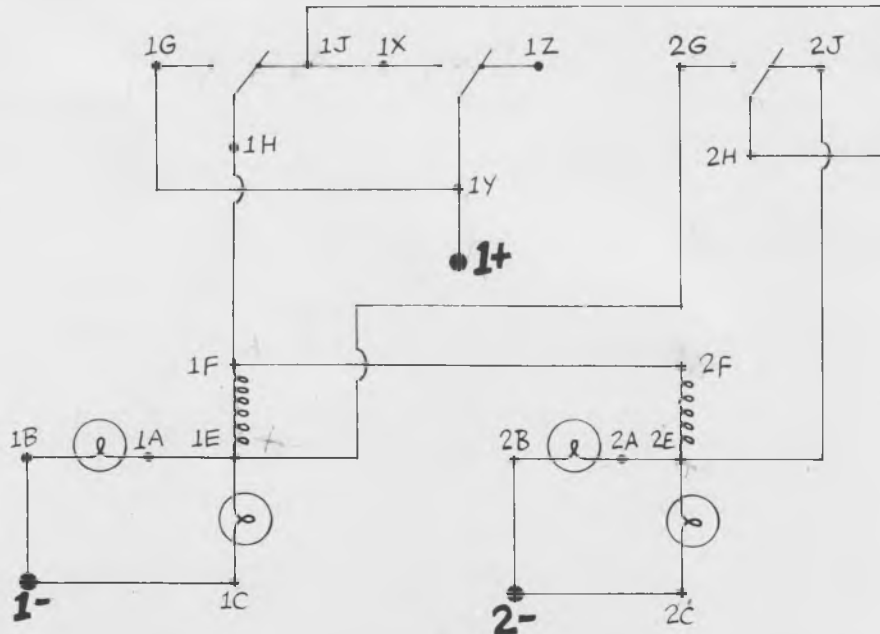

PROGRAMMING NOTES: The answers to the problems are correct, but they are not the only correct answers. This space is for your own programming notes.

MINIVAC 601 AND THE MINIVAC MANUAL

ARE PRODUCTS OF:



372 Main Street, Watertown, Massachusetts