

Notes and Corrections to the Minivac Manual

In response to questions from MINIVAC owners, Scientific Development Corporation has prepared this sheet of notes and corrections to the six-book set of instruction manuals. Should you have any questions which are not answered here, please do not hesitate to contact us at 372 Main Street, Watertown, Massachusetts.

Always be certain that the power is OFF when you are either wiring a program or removing one from the board of the MINIVAC. This will prevent any accidental short circuit and is a good safety habit as well.

All + and - terminals are connected together. For example, a connection to 1+ is the same as a connection to 3+, 6+, or M+. Similarly, a connection to 2- is the same as a connection to 4-, 5-, or M-.

If you should run out of long programming wires, you can use shorter wires by programming through any common terminals not being used in the circuit. In addition to those terminals specifically marked "common," *common terminals* are any set of terminals which are interconnected: for instance, the two terminals at 6R, the six at M10, or the four at 3com.

For example, to make the connections 1X/6A without using the longest wires, you can make the two connections 1X/4R and 4R/6A. If slide switch 4 is being used in the circuit, you can make the connections 1X/4com and 4com/6A. Either of the two examples just given will produce the same result as making the single connection 1X/6A.

Should you find that your programs are frequently not working properly, refer to the Maintenance Manual to be sure that all components are in good operating condition.

If a program is not operating correctly, follow these steps:

1. Check with this "Notes and Corrections" sheet.
2. Check the operating instructions to be sure that you are following the correct procedure. Also, try carrying out the procedure slowly; some programs are not designed for high-speed operation.
3. Check all programming connections; if there is an error, correct it and then check the circuit breaker. If a programming error has caused a short circuit, push the circuit breaker after correcting the error.
4. If the program uses relays, check to see that the relays are free to operate. If necessary, replace short programming wires with longer ones so that the wires do not interfere with the movement of the relay arms.

Notes and Corrections by page

BOOK I

- ✓ page 13: circuit diagram incorrect - delete line connecting 1B and 2B.
- ✓ page 24: "MOTOR REVERSING" circuit diagram incorrectly labeled - change 6Y to 6V.
- page 28: Problem 7: Note that light 1 and relay 1 should both be on *only* if *both* pushbutton 1 and pushbutton 2 are DOWN.
Problem 18: Note that pushbutton 5 is used to keep the rotary switch from stopping at DO when pushbutton 6 is being held down.

BOOK II

- page 10: third complete paragraph, second line - change DOWN to ON.
- page 11: program correction for "TWO-BUTTON RELAY MEMORY CIRCUIT" - change 1A/1C to

1A/1G; delete 1A/1C connection on circuit diagram.

page 14: program correction for Experiment 6 - change 2Z/2C to 2X/2C.

BOOK III

page 36: circuit diagram for COMPUTER REPRESENTATION OF THREE STATEMENTS:

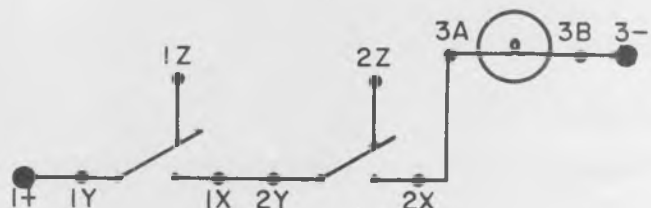

page 38: insert "THEN" between statements B and C in first statement set (1x1=1).

page 40: paragraph directly below COMPUTER REPRESENTATION OF THREE "NOT" STATEMENTS — second sentence should read:

"Light 3 comes ON if pushbutton 1 is pushed and . . ."

page 41: Note — the operation EITHER BUT NOT BOTH is often referred to as the EXCLUSIVE OR. Notice the "exclusive" nature of statements A and B in the example: if *either* A or B is true, then C will also be true. However, if *both* A and B are either true or not true, then C will not be true.

page 43: second line on page should read:
 ". . . relay 2 is ON (=1) then light 3 will be ON (= 1). Symbolically. . ."
 program correction for "Relay AND Circuit" — change 2+/2H to 1G/2H.

page 46: The complementarity laws should be written:

- 1) $A \times \bar{A} = 0$
- 2) $A + \bar{A} = 1$

page 54: program correction for "Mind Reading" program —

change 5V/45 to 5V/4S

Note: Zero (0) is considered an even number for this problem.

page 58: The condition for the statement "It is impossible that the statements 'Sara should' and 'Camille could not' can both be true" should be stated as:

$$\bar{C} \times S = \text{error or } C + \bar{S} = \text{truth}$$

page 59: circuit diagram for "Boolean Solution" is incorrectly labeled — change 1R, 1S, 1T on far right slide switch to 3R, 3S, 3T respectively.

page 61: CIRCUIT REPRESENTATION incorrect — insert "E" before negative power connection:



page 62 Note — when attempting solutions to the Farmer's problem, follow these steps:

place the farmer and an additional passenger in the boat (move the appropriate slide switches LEFT)

move the boat across the river (push pushbutton 6 to cross the river; push pushbutton 1 for the return trip)

unload the boat (move the slide switches RIGHT)

These steps should be repeated until the farmer and all his possessions are across the river. Notice that the farmer may make trips alone.

BOOK IV

page 69: Note — push pushbutton 6 slowly when operating the single-input flip-flop. Light 6 will go off and on, indicating the state of the whole flip-flop.

page 71: chart title incorrect — change "Pushbutton carry" to "Pushbutton."

page 72: Note on "Three-Bit Binary Counter" — the design of this counter is such that the capabilities of the relays are somewhat strained. Relays which perform to satisfaction in every other case may not perform adequately in this circuit. If the counter in Book IV does not perform correctly, use the program and circuit which follow. The circuit below by-passes the relay indicator lights so that full voltage is supplied to the relay coils, causing them to pull in more reliably.

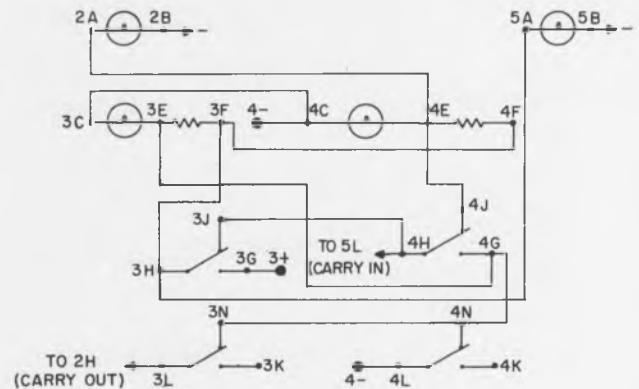

THREE-BIT BINARY COUNTER — ALTERNATE CIRCUIT
 (Middle Stage Only)

Program for alternate counter:

1A/2E	2C/2-	3H/5A	5F/6F
1B/1C	2E/2J	3J/4H	5F/5H
1B/2B	2G/2N	3N/4N	5G/5+
1C/2C	2H/3L	4B/5B	5H/6A
1E/2G	2L/2-	4C/4-	5J/6H
1F/2F	3A/6E	4E/4J	5N/6N
1F/1H	3B/4B	4G/4N	6C/6-
1G/1+	3C/4C	4H/5L	6E/6J
1H/4A	3E/4G	4L/4-	6G/6N
1J/2H	3F/3H	5B/6B	6H/6X
2A/4E	3F/4F	5C/6C	6L/6-
2B/3B	3G/3+	5E/6G	6Y/6+

Procedure: Use the procedure on page 72 of Book IV. When pushing pushbutton 6, be sure to hold the pushbutton down long enough for any carry to propagate to the highest stage of the counter.

page 73: Experiment 2 — use the above circuit if necessary.

Experiment 3—If you used the alternate circuit for experiments 1 and 2, use it for this experiment as well. To modify the **alternate circuit** for a universal counter, make the following changes:

remove	
3N/4N	5N/6N
add	
3K/4V	5K/6V
3N/4S	5N/6S
4J/4W	6J/6W
4N/4R	6N/6R

Follow the procedure on page 73 with this exception:

the counter will count UP when BOTH slide switch 4 and slide switch 6 are LEFT

the counter will count DOWN when BOTH slide switch 4 and slide switch 6 are RIGHT.

page 77: Experiment 6 — Note that the connections to M10 indicate the "end-around carry." This is the "carry out" of the high order stage, and will be used when the adder is converted to a subtractor for experiment 7. (See page 78).

page 79: Note on Experiment 7 — if you used the alternate circuit for the counter, make the following changes to the program for a three-bit subtractor:

first, build the adder and modify it for a subtractor

then, make the following changes:

remove	add
2C/2G	2E/2G
3C/3G	3E/3G
5C/6K	5E/6K
6C/6F	6C/M10
6F/M10	6F/M+

Note that relay indicator light 6 will come ON if the subtraction has proceeded properly.

Relay indicator light 6 ON indicates that there has been an "end-around carry"—that is, a carry out from the high order stage.

page 80: Note — An **accumulator** must be capable of shifting and so must include a shift register. A **shift register**, however, need not be capable of accumulating (see automatic shift register — page 86).

page 82: Note that decimal 60 is 111100 in binary. It is written incorrectly in two places.

page 83: Program correction for Experiment 10:

remove	add
2C/3G	2E/3G
2Y/6S	2Y/3G
3C/4G	3E/4G
5C/6K	5E/6K
6F/M10	6C/M10
	6F/M+

BOOK V

page 2: Experiment 1 — Note that moving either slide switch will change the light to the opposite state (ON or OFF), regardless of the position of the other slide switch.

page 10: second sentence on page should read: "The same will be true for a train moving right through. . ."

page 11: First sentence under "To use the program" (experiment 8) should read: "Set the 'elevator' at the first floor by pushing pushbutton 5."

page 11: Experiment 9 program corrections:
change 4G/4H to 4G/5H
change D16/M- to D16/M+

Note: It is possible for the "elevator" to get stuck at a floor. This happens when the pointer knob stops between adjacent terminals — for example, between D6 and D7 — and is not making proper connection with either. In such case, move the pointer knob so that it is pointing directly at one of the terminals.

Note: If the performance of the circuit is unsatisfactory, make the following changes to the program:

remove	add
5F/6C	5F/6E
6C/6-	6E/6-
	4E/6C

page 12: program corrections for automatic toll collector:

remove	add
3J/4X	3J/4K
3N/6Y	3Y/4Y
4H/5N	4J/4X
4K/5N	4X/6L
5L/6G	5N/6K

pages 21 and 22: Note — when programming a geometric form or a numeral for recognition, be sure that the connections from M10 are made to the TOP terminals in the matrix.

page 24: Experiment 14 program correction:
change 4F/5G to 4F/4G

page 25: Note — to re-set the automatic sequence control, turn power OFF, then ON again.

page 30: "CQ" transmitter program correction:
change 5X/6E to 5X/6C
(correct circuit diagram to correspond)

page 31: Note — Light 6 flashes on very briefly when indicating a dot. The three successive dots may be so rapid and so close together that they are almost indistinguishable. To see them more clearly, slow the rotary switch down by holding the pointer knob back during one revolution.

page 33: Note to Experiment 19 — always turn the pointer knob **clockwise** when indicating a letter for coding.

page 35: Last paragraph on page — third sentence should read:
"Light 6 will flash on whenever . . ."

BOOK VI

The Secret Code (page 51):

Note — to re-set the game, turn power off, then on again.

The Combination Lock (page 52):

Note — to re-set the game, turn the rotary switch through one complete revolution.

The Electronic Maze (page 53):

Note — to re-set the game, turn power off, then on again.

The Match Game (page 55): The first two sentences under "To Play the Match Game" should be changed to:

"Turn the rotary switch to 15, indicating that there are 15 matches in the pile."

Tic-Tac-Toe (page 55):

Note — if the game is a tie, MINIVAC will indicate a tie on the fifth move but will not indicate a move into the last available space.

The Mind Reading Trick (page 57):

Note — Zero (0) is considered even for this problem.

Reaction Time Tester (page 60):

Note — to prevent the players' anticipating the start signal, either make dummy connections to the rotary switch or cover the dial with an inverted box.

Scientific Development Corporation is preparing for a second edition of the MINIVAC Manual. Your comments and suggestions will be appreciated. We are particularly interested in new circuits, games, etc., for the MINIVAC. Please address correspondence of this nature to the Editor of the MINIVAC Manual: Linda G. Sprague.



372 Main Street, Watertown, Massachusetts