

REVISIONS			
LTR.	ECO	APPROVAL	DATE
--	--	--	
--	--	--	

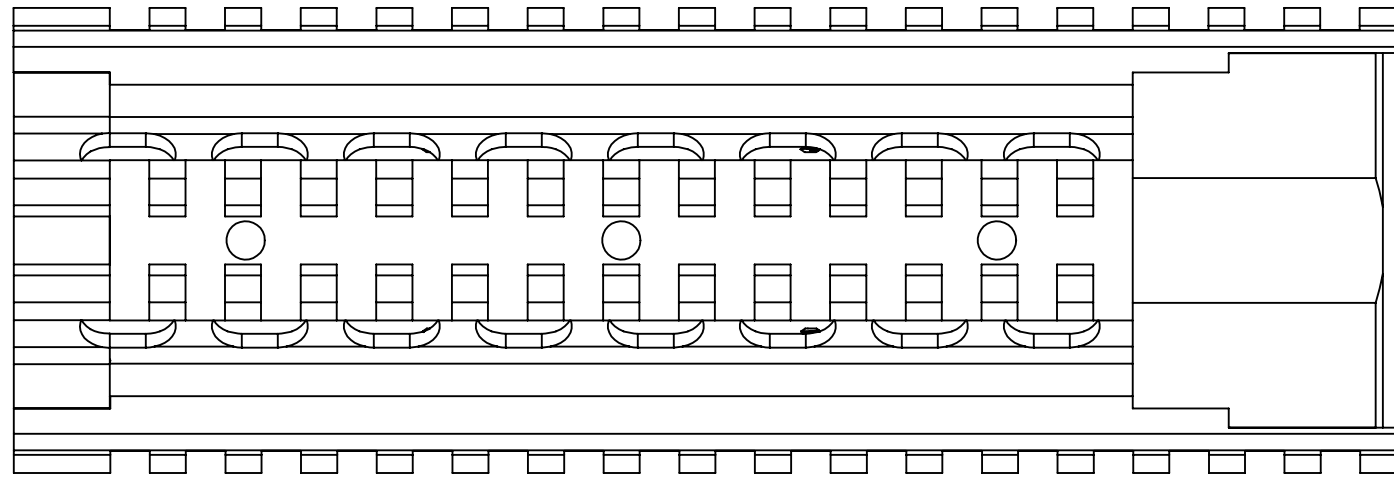
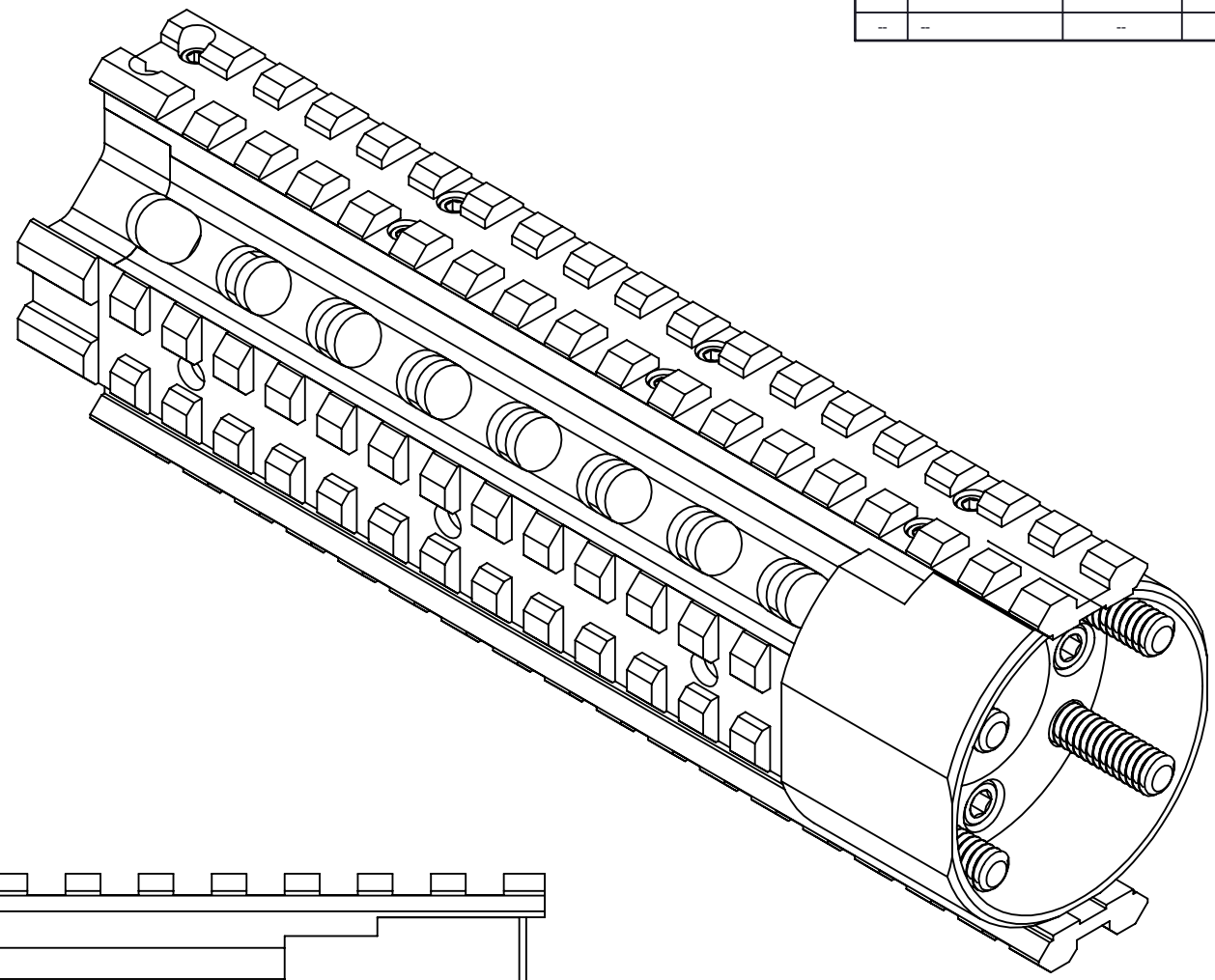
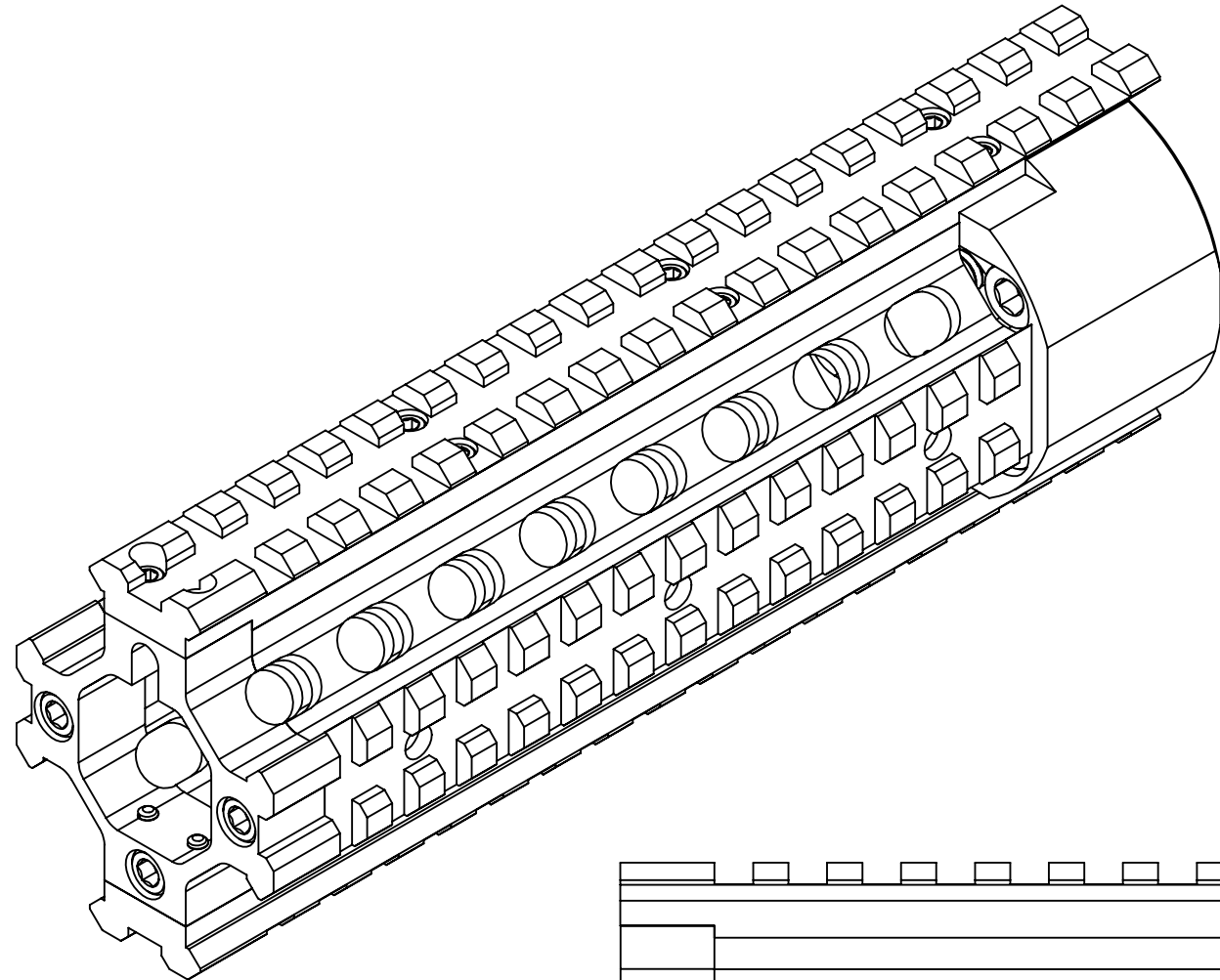

AEROSTAR INTERNATIONAL, INC. RESERVES ALL PROPRIETARY RIGHTS TO INFORMATION DISCLOSED HEREIN; INCLUDING RIGHTS OF PATENT, COPY-RIGHT, USE, SALE, MANUFACTURING AND/OR REPRODUCTION

UNLESS OTHERWISE SPECIFIED	CHECKED: --
DIMENSIONS ARE IN INCHES	PROJ. ENG. --
ONE PLACE DECIMALS ±0.06	PRODUCTION: --
TWO PLACE DECIMALS ±0.03	CUSTOMER --
THREE PLACE DECIMALS ±0.010	MATERIAL -
FRACTIONS ±1/4	FINISH -
ANGLES ±0.5°	
BREAK EDGES .005-.015	
FABRIC DIMENSION TOLERANCES	
N/A	
NEXT ASSEMBLY	

NOTICE:
THIS DRAWING AND THE INFORMATION PROVIDED ARE PROPERTY OF RAVEN INDUSTRIES INC., AND MAY ONLY BE USED AS AUTHORIZED BY RAVEN INDUSTRIES INC.
ALL RIGHTS RESERVED UNDER THE COPYRIGHT LAWS.



TITLE PROJECT NAME			
DRAWING NAME 1			
DRAWING NAME 2			
CODE IDENT NO.	SIZE	DRAWING NUMBER	REVISION
49816	B	--	--
SCALE 1:1		SHEET 1 OF 10	

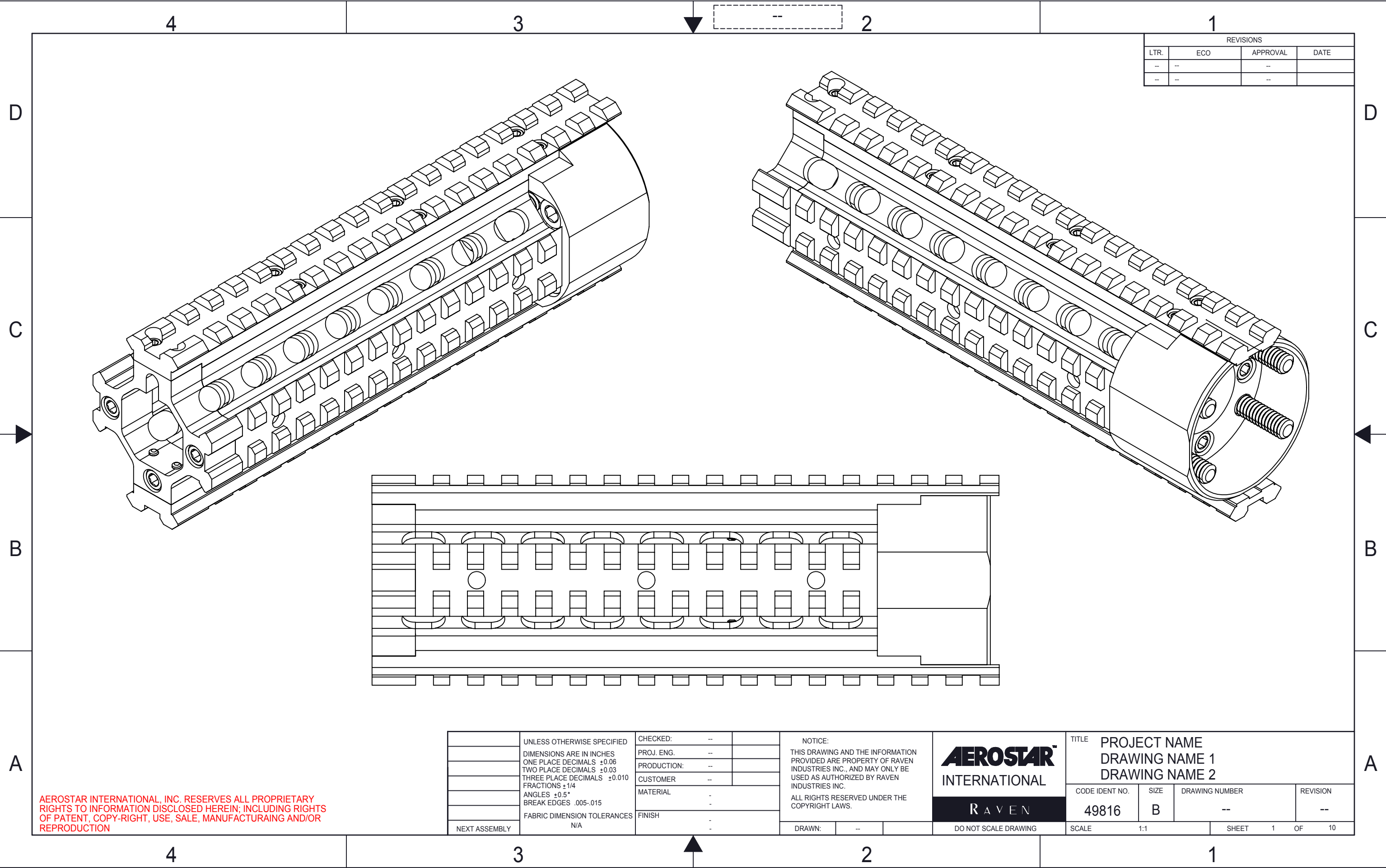

REVISIONS	
SEE SHEET 1 FOR REVISIONS	

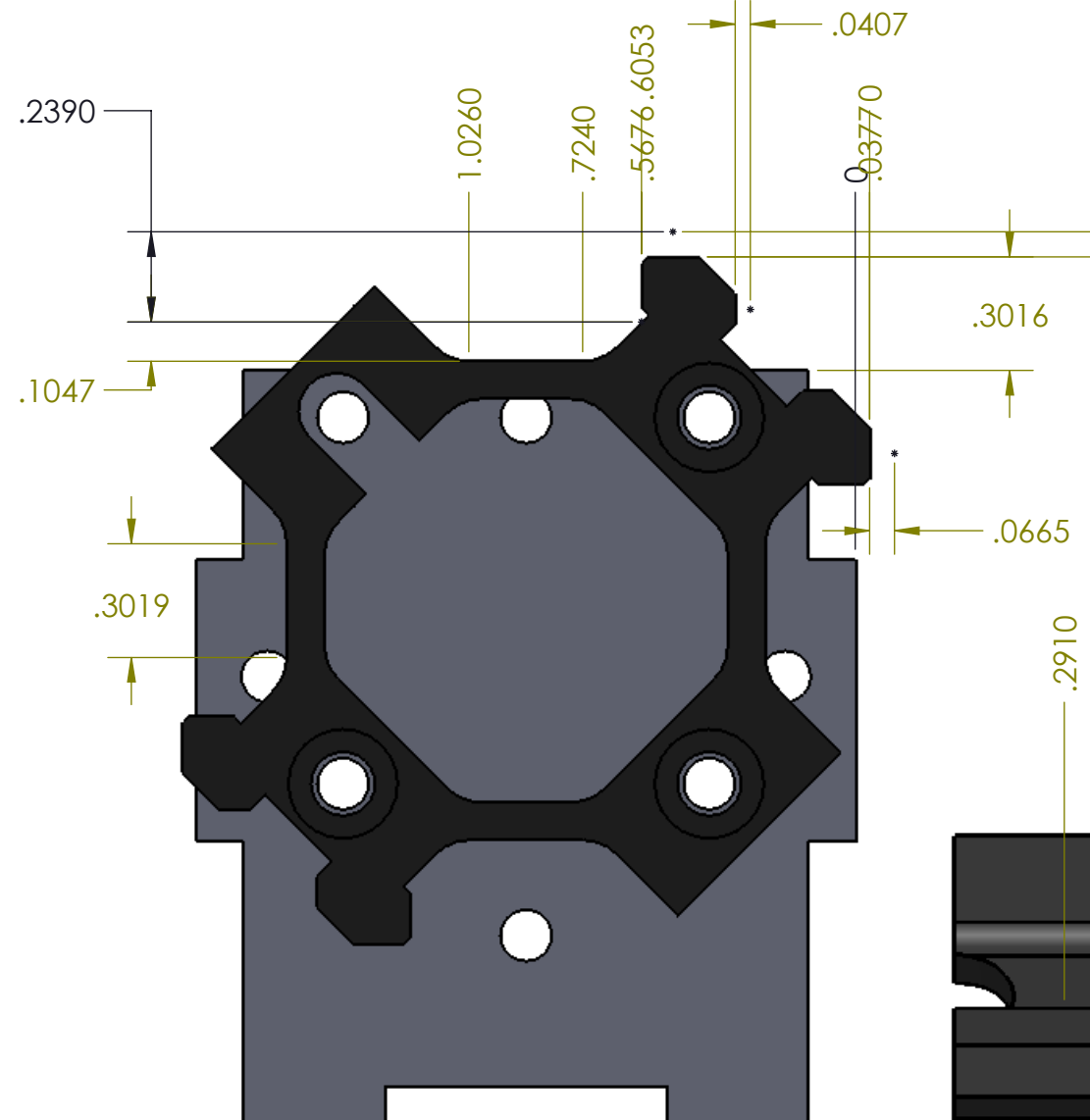

make 2 with #8 holes for tight fit to use as angle stand

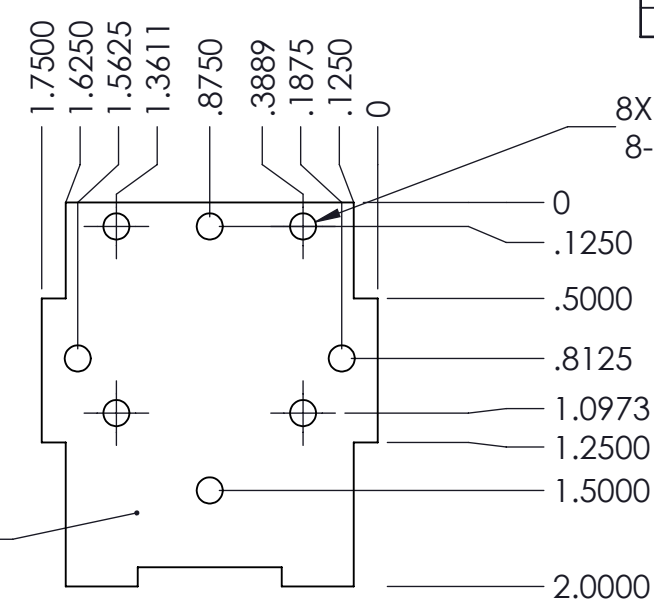

8X ϕ .1360 THRU ALL
8-32 UNC THRU ALL

C
B
A

C
B
A

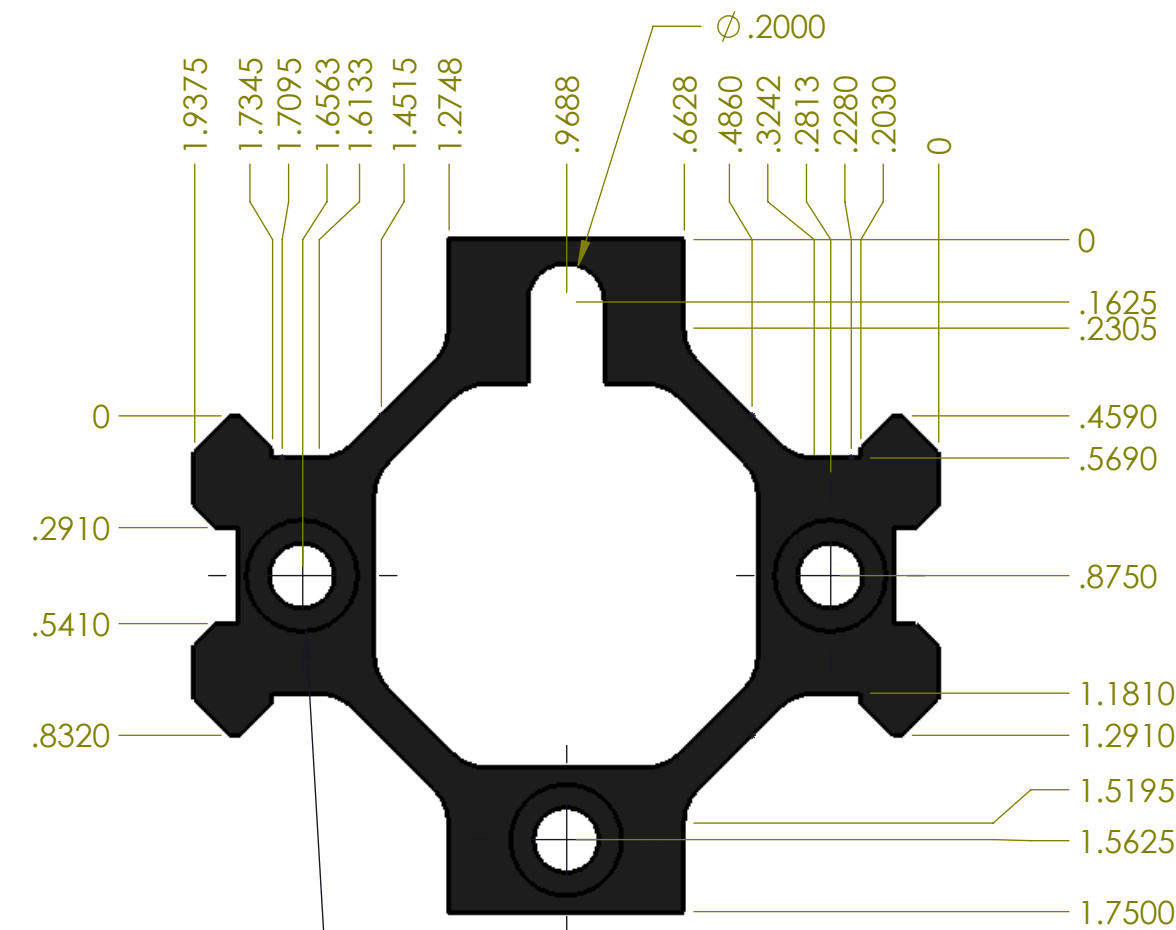
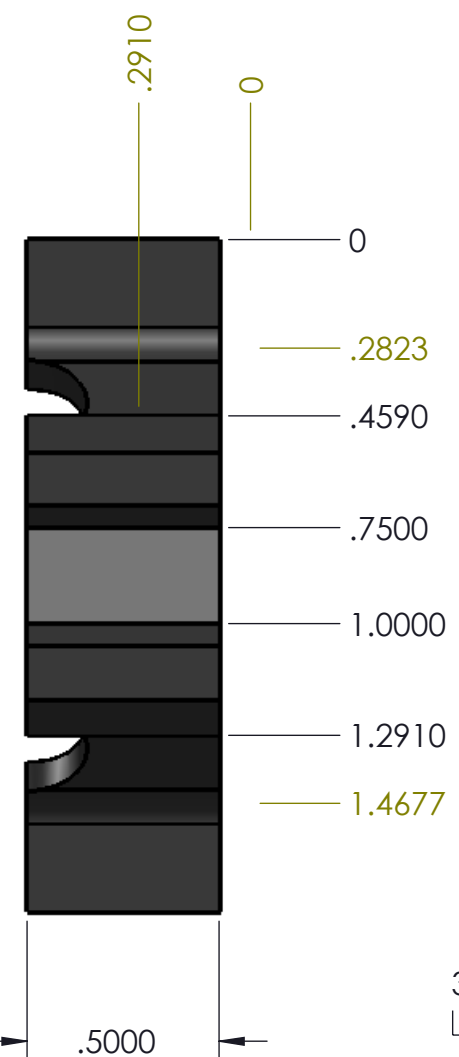

3X ϕ .1695 THRU ALL
 \square ϕ .2900 ∇ .2690

CODE IDENT. NO.	SIZE	DRAWING NUMBER	REVISION
14979	B	--	--
DO NOT SCALE DRAWING		SCALE 2:1	SHEET 3

4 3 2 1

REVISIONS	
SEE SHEET 1 FOR REVISIONS	

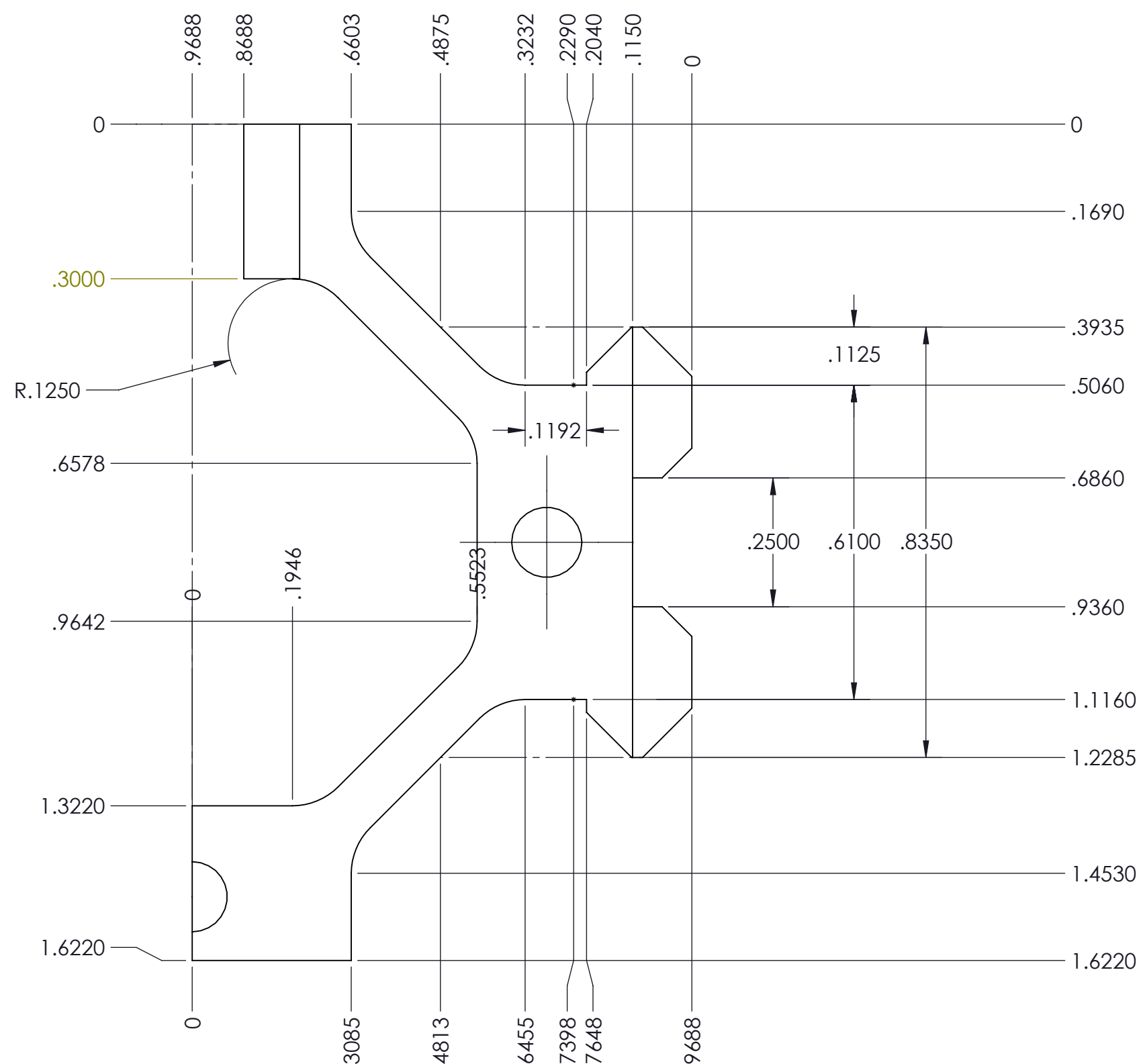

1.6220" x .9688" x 5.3275" blank

CODE IDENT. NO. 14979	SIZE B	DRAWING NUMBER --	REVISION --
DO NOT SCALE DRAWING		SCALE 4:1	SHEET 4

REVISIONS
SEE SHEET 1 FOR REVISIONS

2X ϕ .1360 ∇ .4200
 8-32 UNC ∇ .3300

1.6563

.9688

.2813

0

.8110

ϕ 1.0000

1.4985

1.6220

CODE IDENT. NO. 14979	SIZE B	DRAWING NUMBER --	REVISION --
DO NOT SCALE DRAWING	SCALE 3:1	SHEET 5	

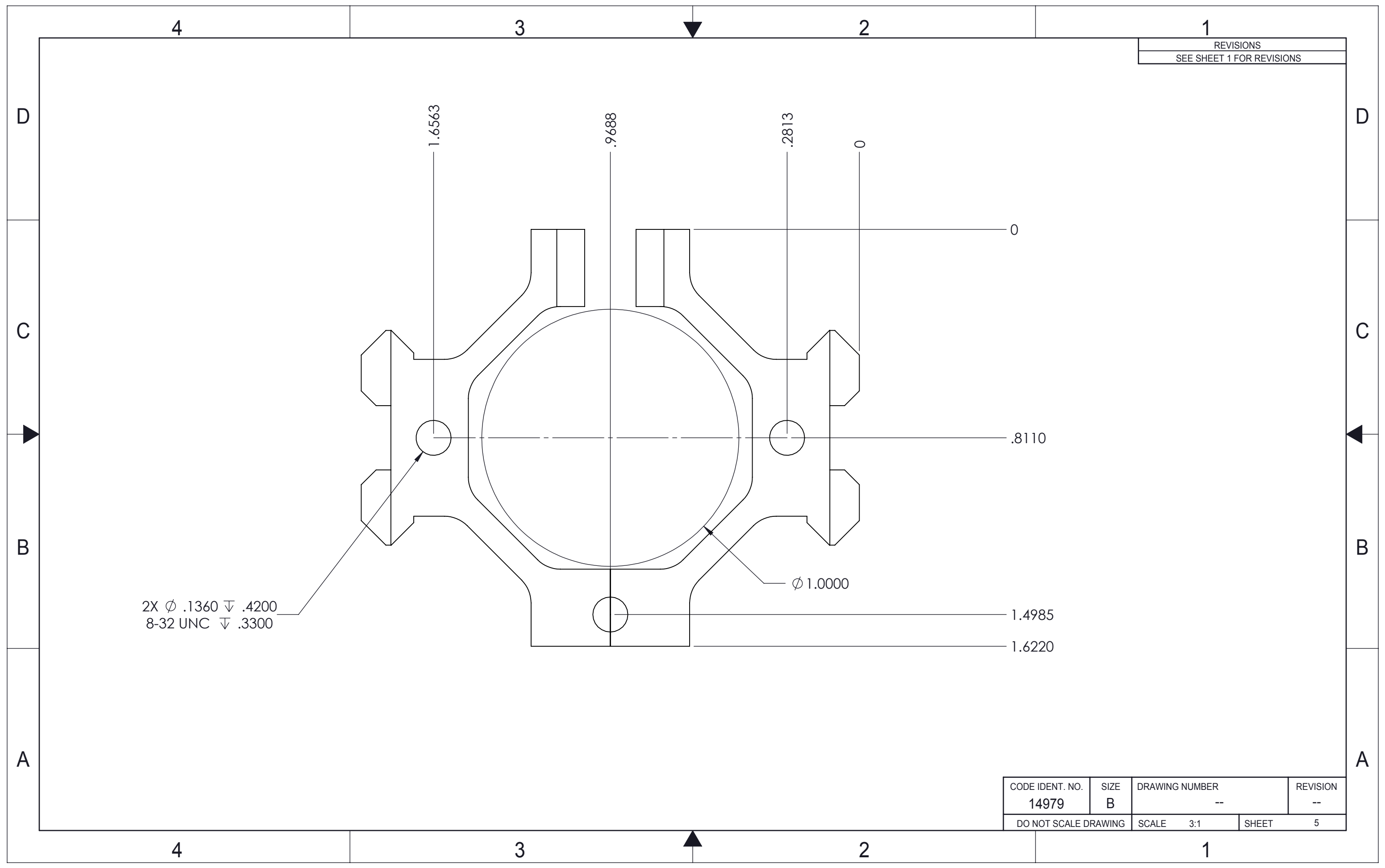

REVISIONS	
SEE SHEET 1 FOR REVISIONS	

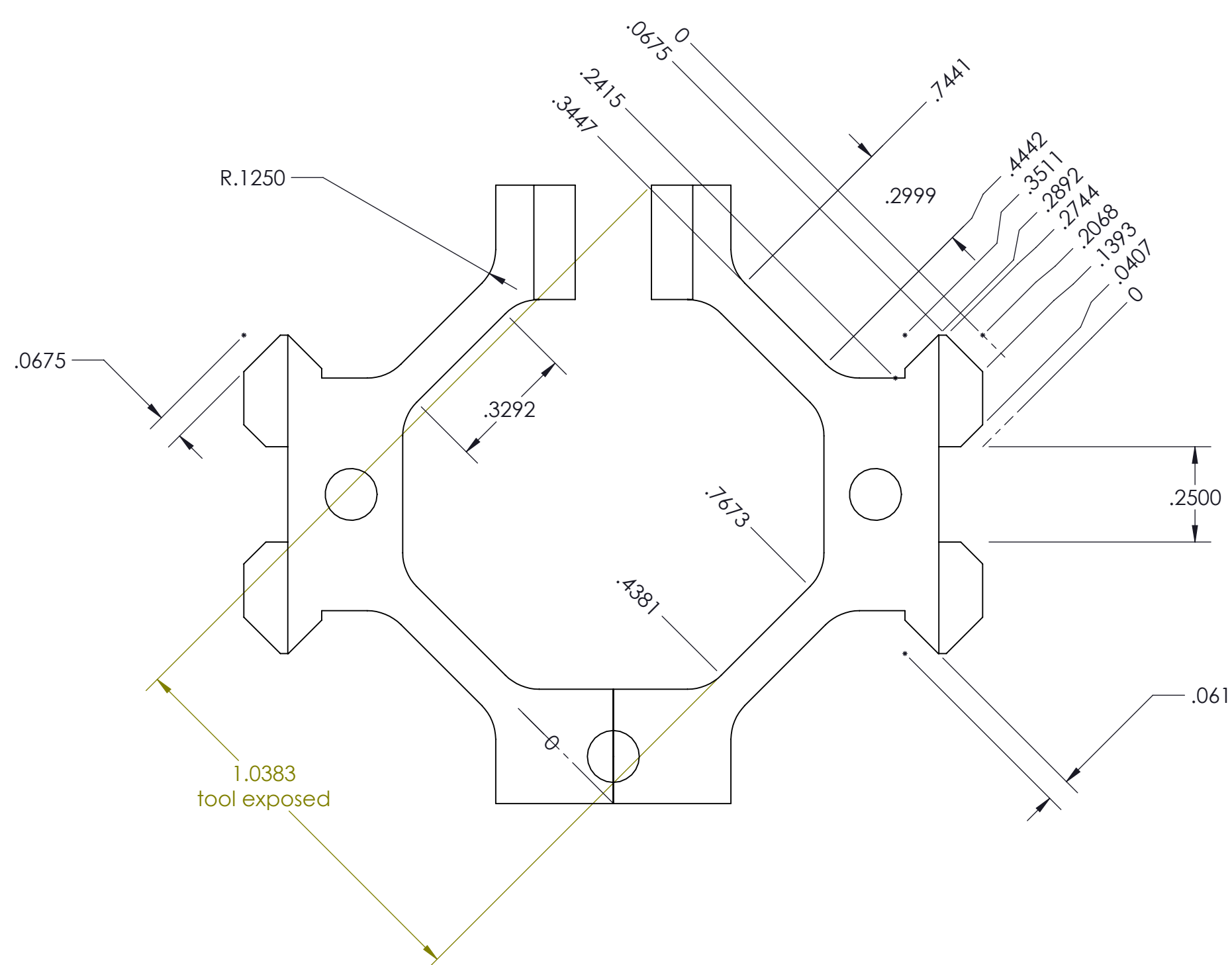

CODE IDENT. NO. 14979	SIZE B	DRAWING NUMBER --	REVISION --
DO NOT SCALE DRAWING		SCALE 3:1	SHEET 6

REVISIONS	
SEE SHEET 1 FOR REVISIONS	

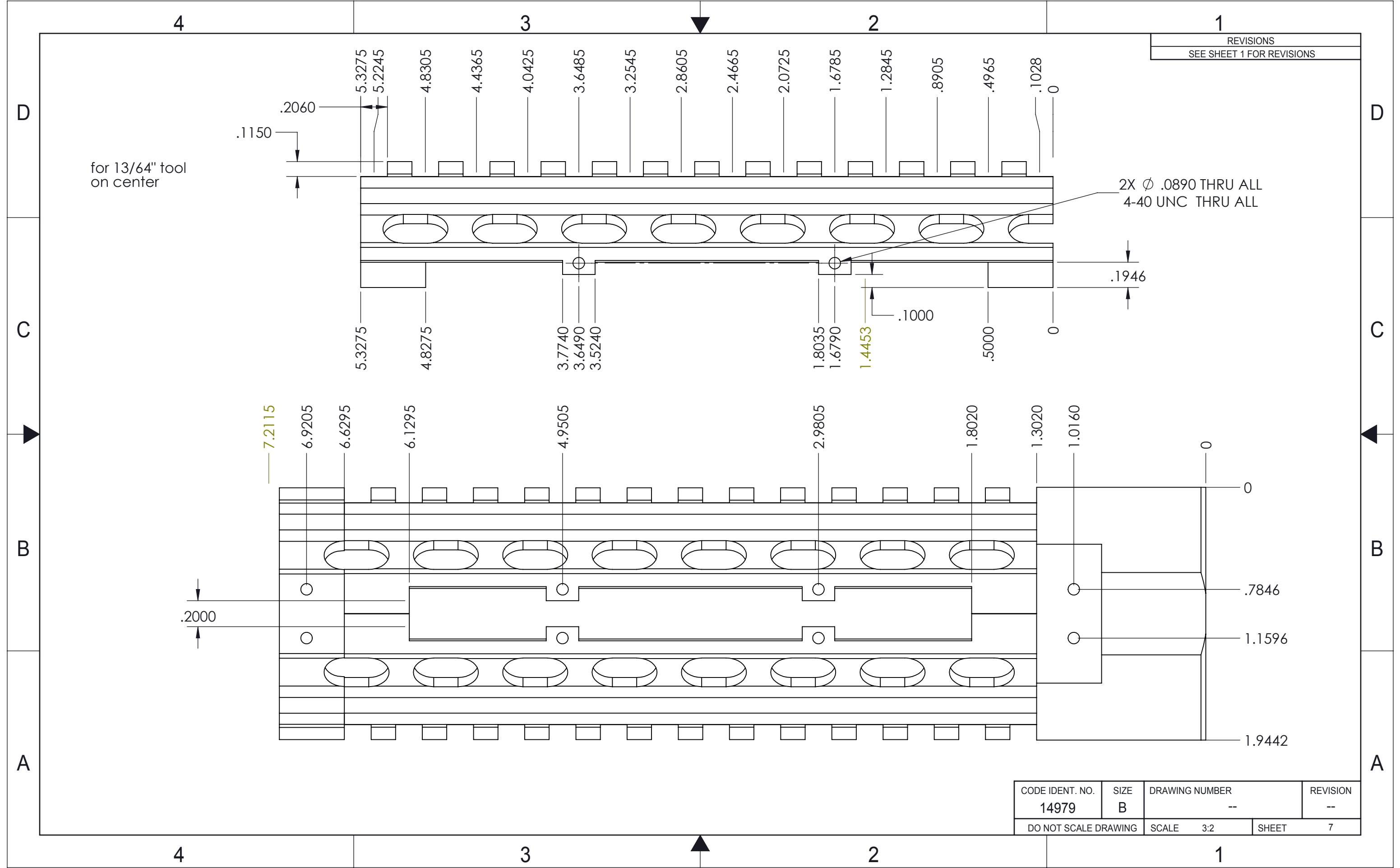

CODE IDENT. NO. 14979	SIZE B	DRAWING NUMBER --	REVISION --
DO NOT SCALE DRAWING		SCALE 3:2	SHEET 7

REVISIONS	
SEE SHEET 1 FOR REVISIONS	

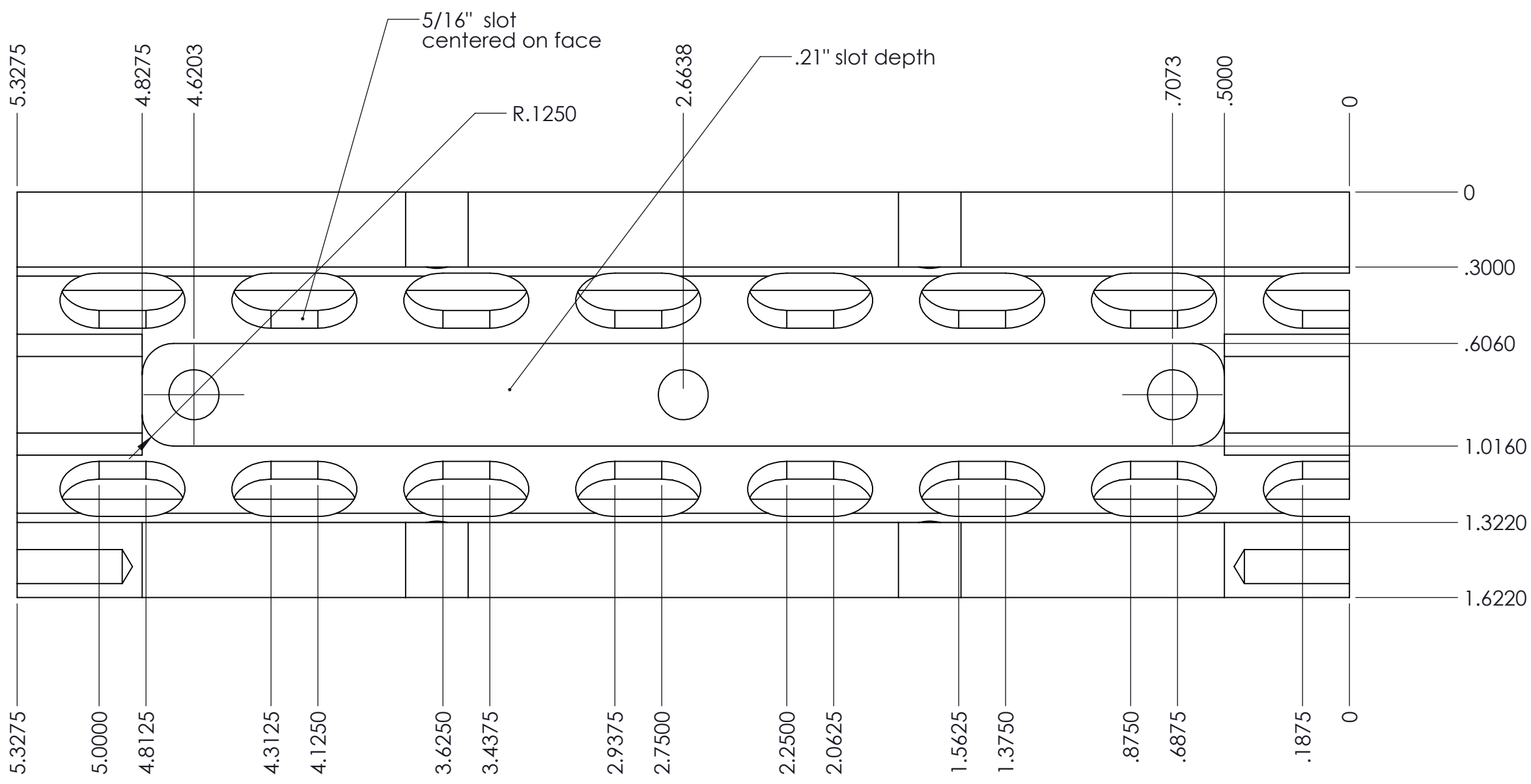

CODE IDENT. NO. 14979	SIZE B	DRAWING NUMBER --	REVISION --
DO NOT SCALE DRAWING		SCALE 2:1	SHEET 8

REVISIONS	
SEE SHEET 1 FOR REVISIONS	

for a 13/64" tool
on center

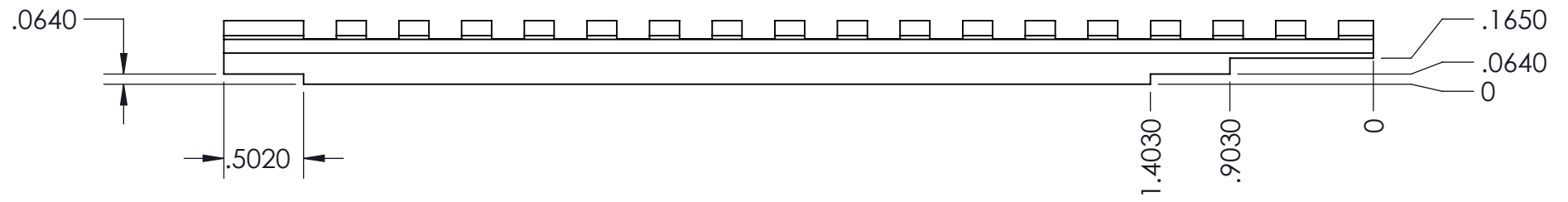
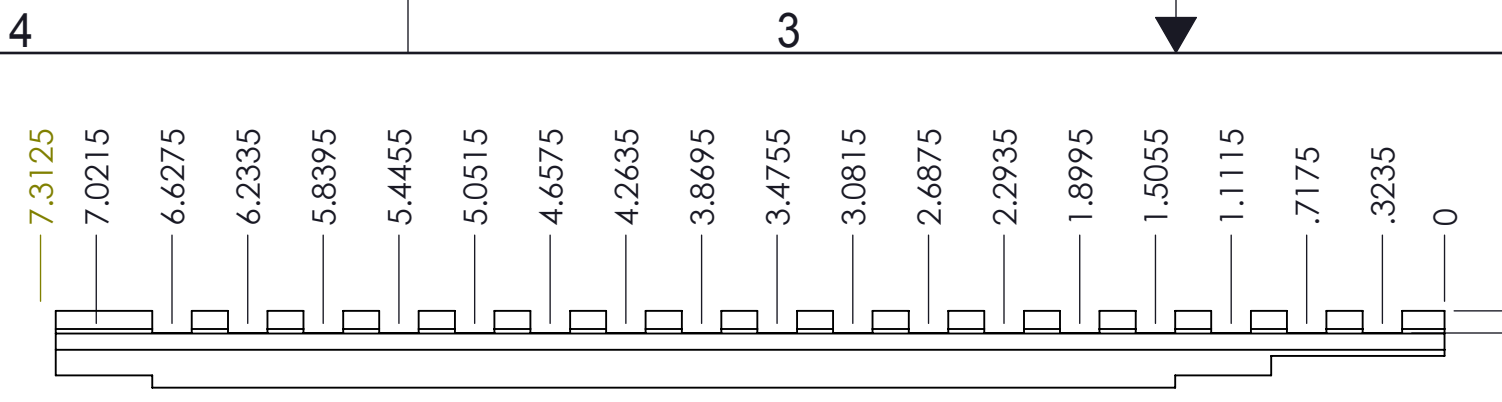

8X ϕ .1160 THRU ALL
 \square ϕ .2000 ∇ .1370

top rail

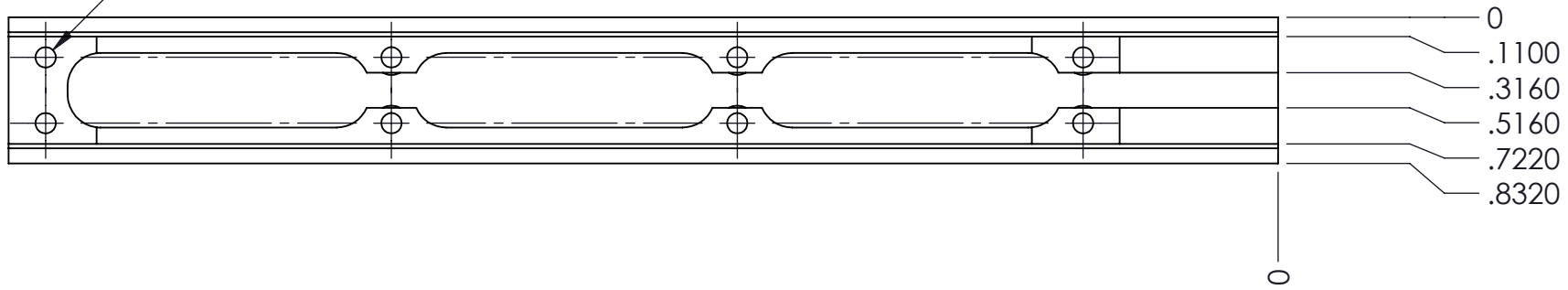

bottom rail

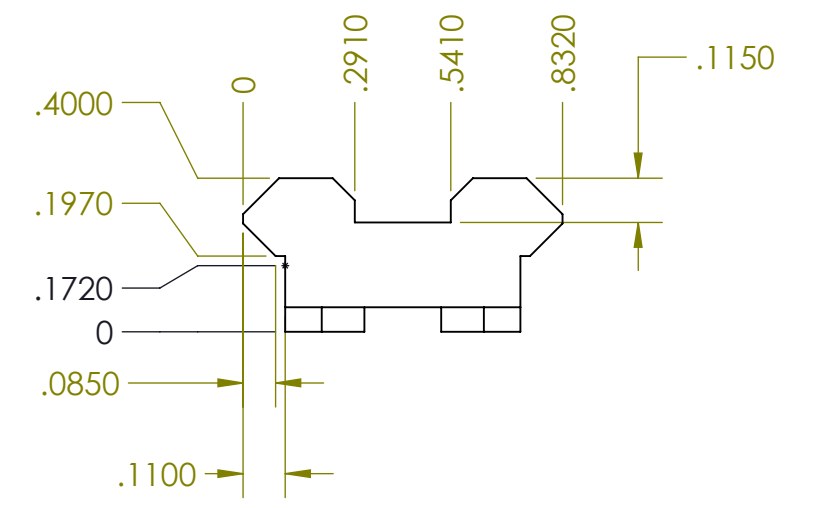
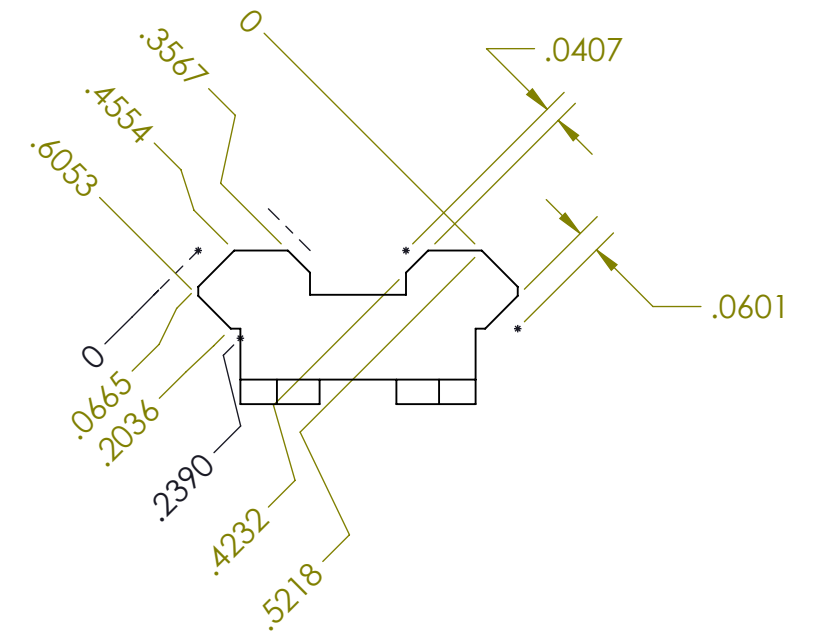
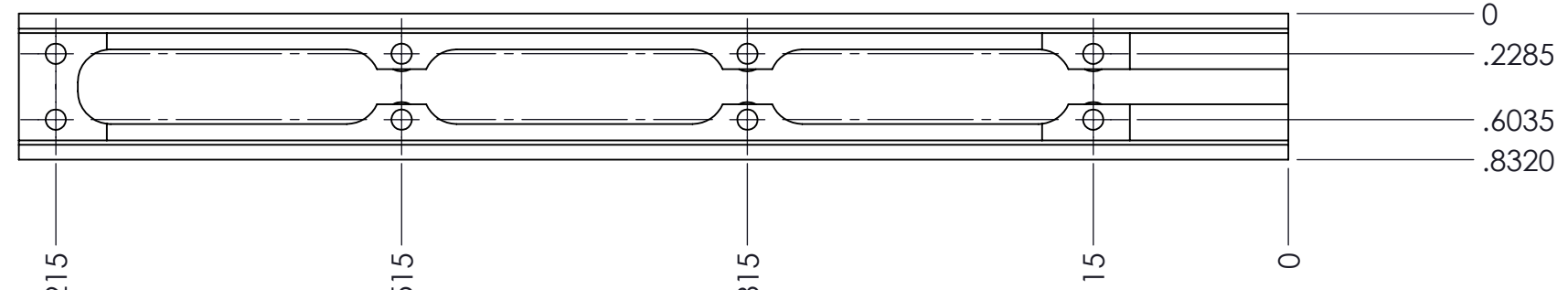

CODE IDENT. NO. 14979	SIZE B	DRAWING NUMBER --	REVISION --
DO NOT SCALE DRAWING	SCALE 1:1	SHEET 9	

REVISIONS	
SEE SHEET 1 FOR REVISIONS	

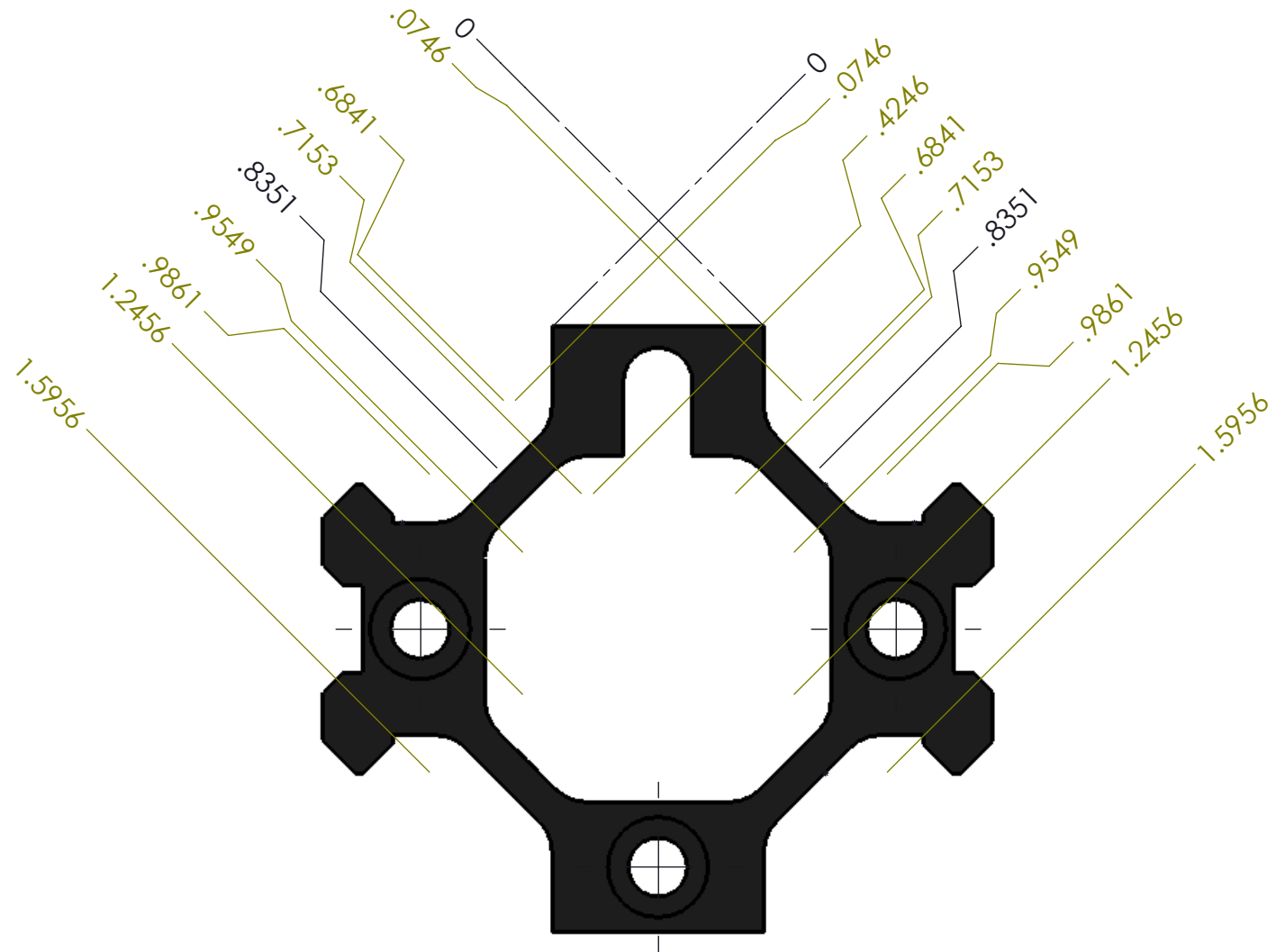
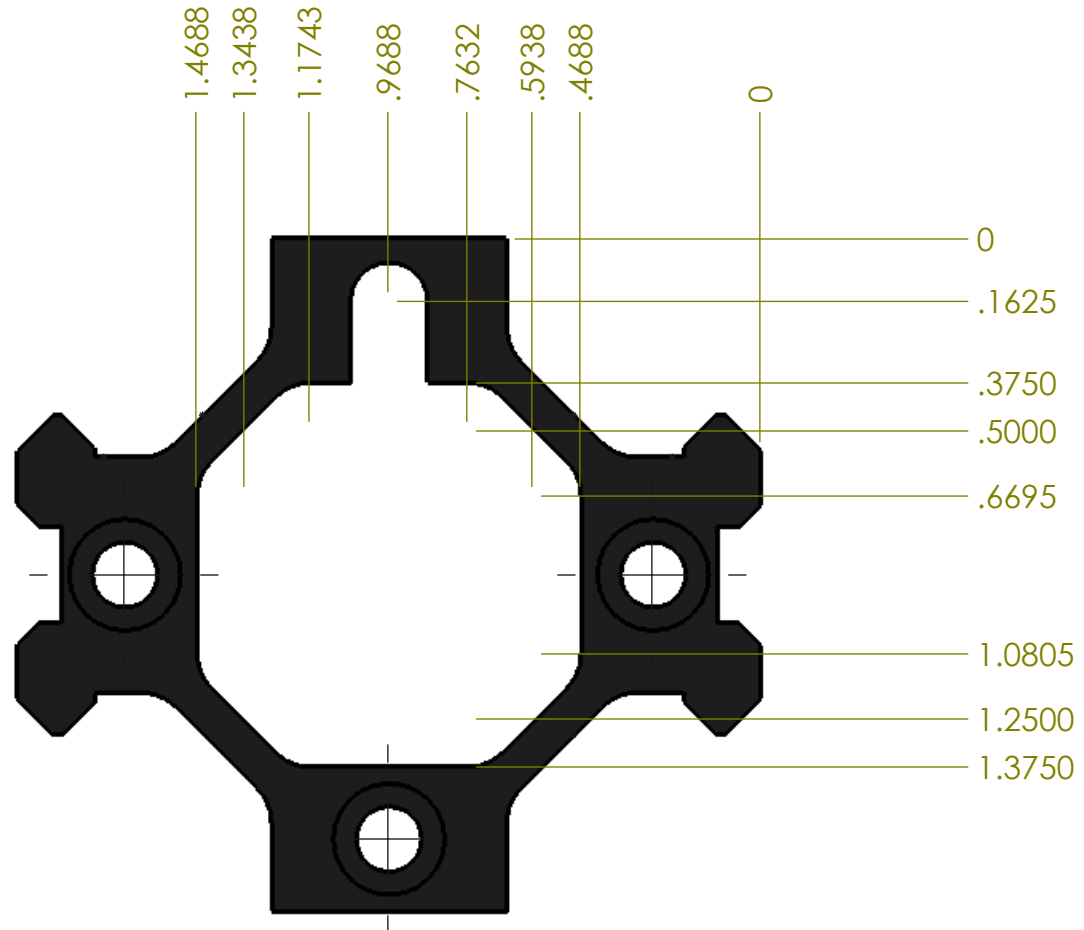

CODE IDENT. NO. 14979	SIZE B	DRAWING NUMBER --	REVISION --
DO NOT SCALE DRAWING		SCALE 2:1	SHEET 10