

# Analog Talking Glow in the Dark 3D Printed Clock

October 2015

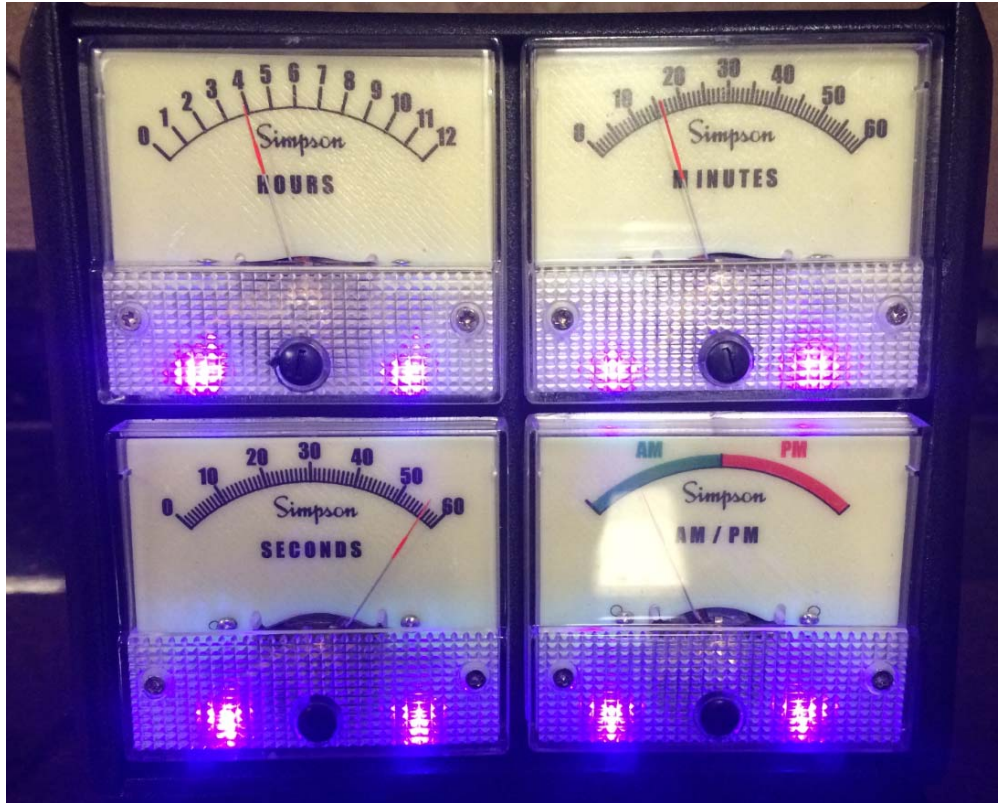

Analog Talking Glow in the Dark 3D Printed Clock Construction



<b>1</b>	<b>DISCLAIMER</b>	<b>4</b>
<b>1</b>	<b>OVERVIEW</b>	<b>5</b>
<b>2</b>	<b>COMPONENTS</b>	<b>6</b>
2.1	ARDUINO MEGA 2560 CONTROLLER	6
2.2	DS1307 REAL TIME CLOCK	7
2.3	MUSIC MAKER MP3 SHIELD	8
2.4	AUDIO SPEAKERS	9
2.5	CLOCK METERS	10
2.6	EXTRA-LONG .1" HEADER PINS & SOCKET CABLE	11
2.7	ULTRAVIOLET LEDs	12
2.8	POWER SUPPLY	13
2.9	RING TERMINALS	13
2.10	FILAMENT	14
2.11	WIRE	15
2.12	PUSHBUTTONS	16
2.13	PAINT	17
2.14	SCREWS	18
<b>3</b>	<b>METER GAUGE DECALS / DESIGN</b>	<b>19</b>
<b>4</b>	<b>3D PRINTING</b>	<b>22</b>
<b>5</b>	<b>CONSTRUCTION</b>	<b>37</b>
5.1	LAYOUT THE LEFT AND RIGHT SIDES	37
5.2	INSERT THE SPEAKER COVERS	38
5.3	INSERT THE SPEAKERS	39
5.4	ASSEMBLE THE ENCLOSURE	40
5.5	GLUE THE ENCLOSURE	41
5.6	ATTACH THE ENCLOSURE BOTTOM	42
5.7	PREPARE THE ENCLOSURE FOR PAINTING	43
5.8	PAINT ENCLOSURE	45
5.9	PREPARE THE METERS – SCALE PLATE & LED HOLES	46
5.10	EPOXY TWO LEDs TO EACH METER	52
5.11	PREWIRE THE METERS	53
5.12	PREPARE THE PUSHBUTTON PANEL	55
5.13	WIRE THE PUSHBUTTON PANEL	57
5.14	EPOXY THE LEDs TO THE PUSHBUTTON PANEL LED HOLDER	59
5.15	SOLDER THE ULTRAVIOLET LED LEADS	60
5.16	ASSEMBLE MUSIC MAKER	62
5.17	ASSEMBLE DS1307	63
5.18	MAKE ARDUINO WIRE CONNECTIONS	64
5.19	WIRING DIAGRAM	65



5.20	PROGRAM ARDUINO AND ATTACH BASE / BUMPERS	66
<b>6</b>	<b>EXAMPLE TIME DISPLAY</b>	<b>67</b>
<b>7</b>	<b>VARIATIONS</b>	<b>68</b>
<b>8</b>	<b>PARTS LISTING</b>	<b>70</b>



## 1 **DISCLAIMER**

This document and the attached drawings are not to be used for construction.

You are hereby authorized to view, copy, print, and distribute the materials from this document or the attached drawings subject to the following conditions:

- The materials are for your personal informational use only and not for commercial purposes.
- No liability in respect of any of the contents of such publications or use thereof is accepted and no warranties expressed or implied are made in relation thereto.

### **Disclaimer**

ANY INFORMATION CONTAINED IN THIS DOCUMENT OR THE ATTACHED DRAWINGS ARE PROVIDED [AS IS] FOR YOUR INFORMATIONAL PURPOSES ONLY, WITHOUT WARRANTY OF ANY KIND, INCLUDING ANY IMPLIED WARRANTY OF MERCHANTABILITY, FITNESS FOR A PARTICULAR PURPOSE, OR NON-INFRINGEMENT. THE AUTHOR OF THIS DOCUMENT AND ATTACHED DRAWINGS WILL IN NO EVENT BE LIABLE FOR ANY DIRECT, INDIRECT OR PUNITIVE DAMAGE OF ANY KIND THAT RESULTS FROM THE USE OF OR INABILITY TO USE THIS DOCUMENT OR THE ATTACHED DRAWINGS, INCLUDING WITHOUT LIMITATION, LOSS OF PROFITS, GOODWILL, OR BUSINESS INTERRUPTION. THE AUTHOR OFFERS NO ASSURANCES, WARRANTIES OR GUARANTEES AS TO THE VALIDITY OR COMPLETENESS OF THIS INFORMATION. INFORMATION WILL BE CHANGED, UPDATED AND DELETED WITHOUT NOTICE.



## 1 Overview

The clock will display the time using 4 analog meters. I have seen these type of clocks in various incarnations but I never saw an analog clock in this format that talked. This clock announces the time at half hour intervals and plays a message whenever the clock is first powered on. Many of these types of clocks use a real time clock module such as this one. The coin cell battery keeps the time when power is removed so the clock will always retain the current time. Most clocks of this type allow the time to be set when the Arduino program is compiled. This is fine except when you have to account for daylight savings time. You must advance or retard the time by one hour twice a year. Recompiling the program is a hassle so I decided to add time set capability to the clock via a rocker switch and pushbutton interface.

The analog meter gauge plates and pushbutton panel are 3D printed in glow in the dark material so they are always visible. I added ultraviolet LEDs to the gauges and the pushbutton panel that will provide a nice purple lighting effect and charge the glow in the dark material.

The power on message and time announce files are provided but can be changed simply by recording new .mp3 files and putting them on the music maker board micro SD card.

The clock is 3D printed and utilizes one Arduino Mega 2560, one Music Maker MP3 shield, one DS1307 real time clock, four rocker switches, one up/down momentary pushbutton switch and 12 3mm ultraviolet LEDs..

The .stl files for printing the clock parts, Arduino code, Meter faceplate template, wiring diagram and the audio files are located here. The files can also be found at [www.guarnero.com](http://www.guarnero.com). The clock was printed on a Lulzbot mini which has a print bed size of 150 mm x 150 mm.

The entire clock was printed with HIPS filament with the exception of the pushbutton panel and the meter scale plates. These items were printed with glow in the dark ABS.

A complete parts list along is provided at the end of this “Instructable”.



Warning: Once the clock has been constructed, people are often mistaken that they may have had a supernatural experience once they bask in the warm glow of the clock and the sound of the angelic voice announcing the time. I assure you, the warm glow is just the ultraviolet LEDs and the angelic voice is my wife.



## 2 Components

### 2.1 Arduino Mega 2560 Controller

The clock utilizes an Arduino Mega 2560 controller. The Arduino Mega 2560 is programmed to monitor and control the time set pushbuttons, Audio on/off switch, Audio announce AM / PM switch, (4) 0-5 volt meters, Interface to the real time clock module, and control playing back the time audio messages.

The Arduino Mega 2560 can be purchased at [Adafruit.com](http://Adafruit.com)

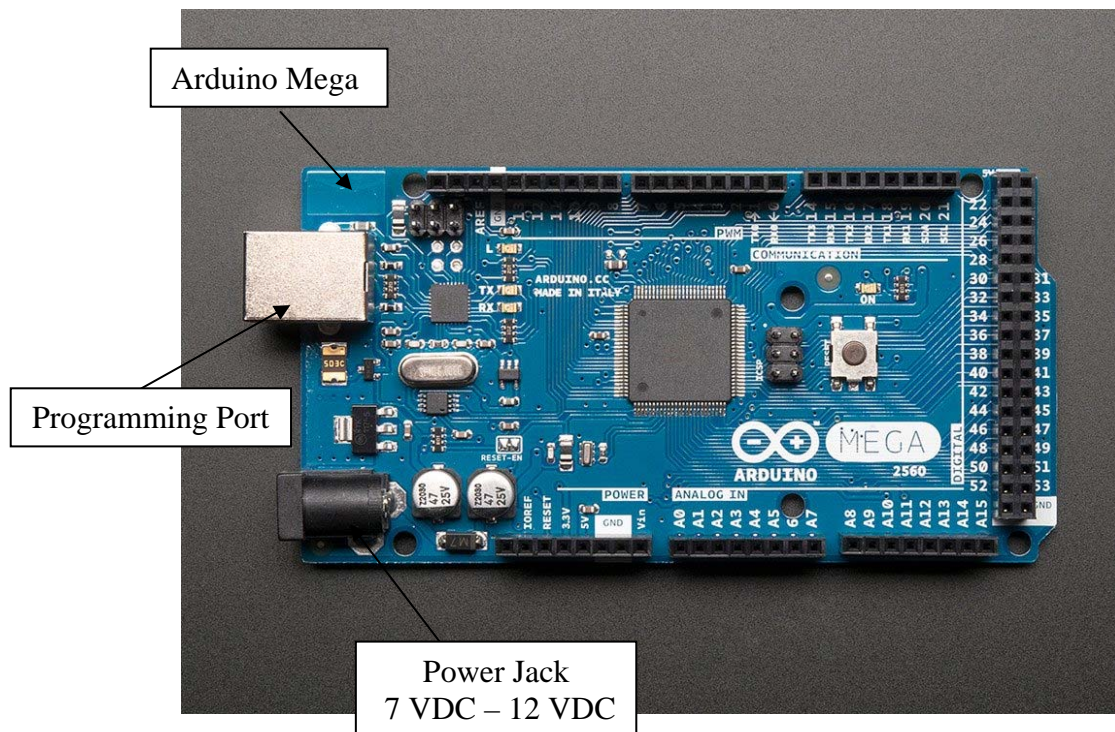

Figure 2.11 – Arduino Mega 2560



## 2.2 DS1307 Real Time Clock

The clock utilizes a real time clock module that will keep track of the time even when power is removed. The DS1307 real time clock module contains a coin cell battery that will keep the time for five years.

The DS1307 Real Time Clock can be purchased at Adafruit.com <http://www.adafruit.com/products/264> . The DS1307 comes as a simple kit that requires a few solder connections. The only connections to the DS1307 module that are required is 5 VDC power and the SDA and SCL pins. The SDA and SCL connections are interfaced to the Arduino Mega pins 20 and 21. This is a simple and inexpensive solution for creating a clock. The DS1307 module mounted to the recess area on the base of the clock.

Note: I also created the same clock with a ChronoDot purchased from Adafruit.com. The ChronoDot requires no assembly and is a more accurate clock module. There are no code changes required if you use the ChronoDot.

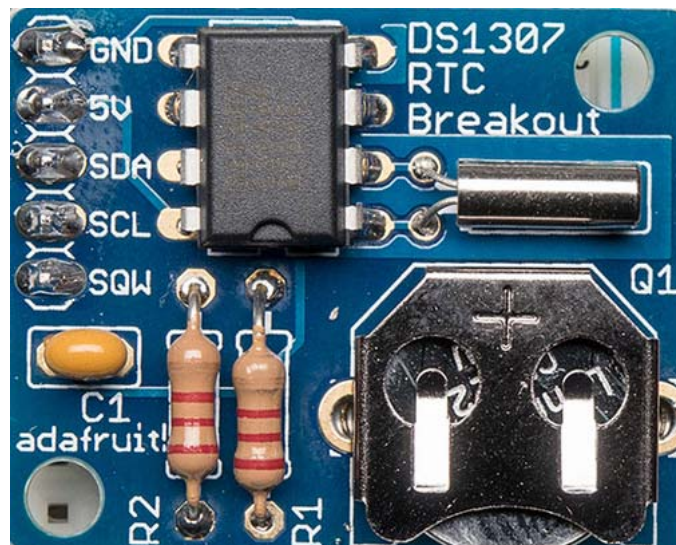

Figure 2.21 – DS1307 Real Time Clock



### **2.3 Music Maker MP3 Shield**

The clock utilizes an MP3 Shield that stores the hourly and half hour audio messages and plays them through the speakers when the Arduino has determined that it is time to announce the time.

The Music Maker MP3 Shield with 3 watt stereo amp can be purchased at Adafruit.com <http://www.adafruit.com/products/1788> . The Music Maker Shield requires some minor soldering prior to usage.

The Music Maker contains an SD card slot that allows audio files to be easily moved between your computer and the Music Maker. Just save the audio file from your computer to the SD card as you normally would and then place the SD card in the Music Maker shield.

The shield may seem like overkill since there are several lower cost audio playback options available but the shield offered the most flexibility and provided a reliable easy to use audio playback device made to interface with the Arduino.

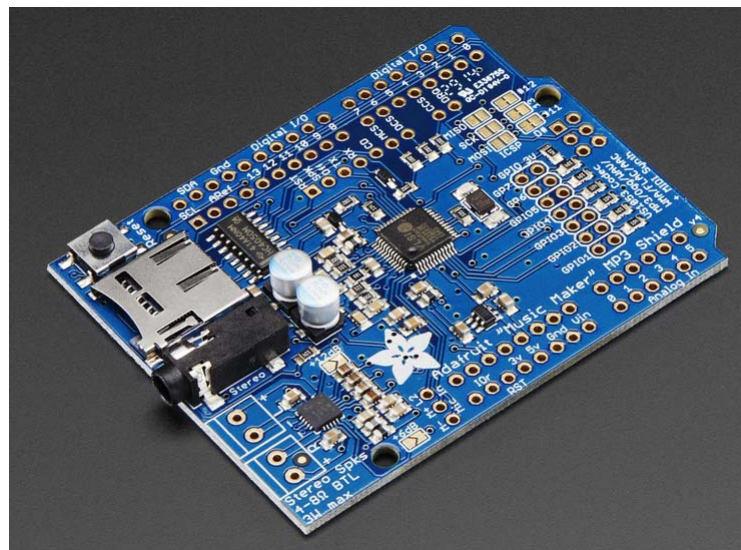

Figure 2.31 – Music Maker MP3 Shield





## 2.4 Audio Speakers

The clock utilizes two speakers driven by the Music Maker MP3 shield. The Music Maker MP3 shield has a 3 watt stereo amp onboard that drives the speakers,

The speakers utilized are a stereo enclosed speaker set (3 watts / 4 ohm) purchased at Adafruit.com <http://www.adafruit.com/products/1669> . The same speakers should be used since the 3D printed cabinet has an internal speaker mounting design based around these speakers.

I cut the 4 pin connector off the speakers since the MP3 Shield utilizes screw terminals for the speaker connection.

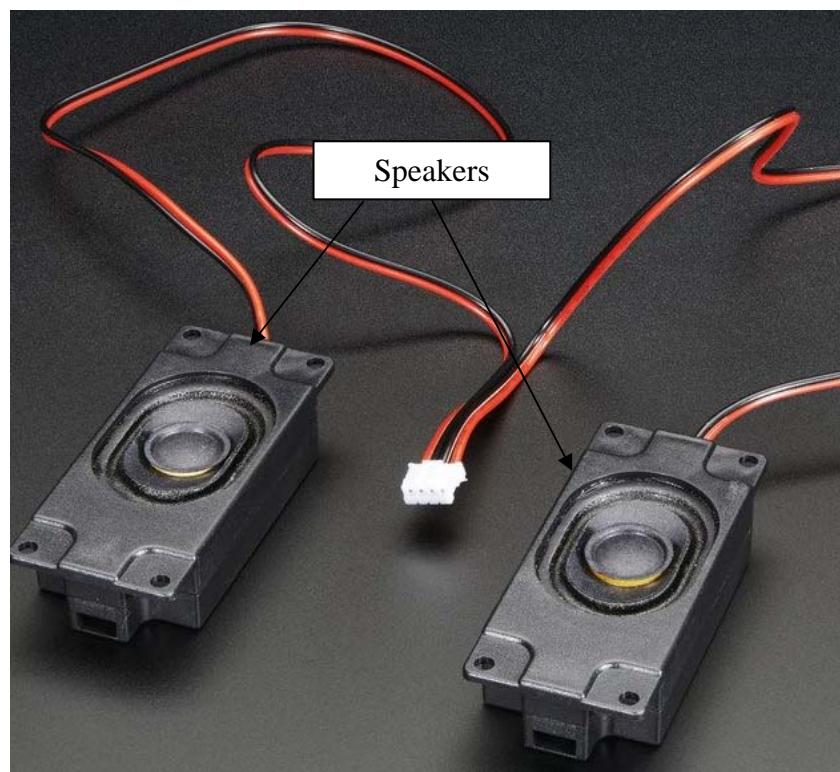

Figure 2.41 – Time Announcement Speakers



## 2.5 Clock Meters

The clock utilizes four 0-5 VDC meters that are driven via PWM pins on the Arduino Mega 2560.

The Meters can be purchased at Amazon.com.com

[http://www.amazon.com/gp/product/B0051E8ONA?psc=1&redirect=true&ref\\_=od\\_aui\\_detailpages00](http://www.amazon.com/gp/product/B0051E8ONA?psc=1&redirect=true&ref_=od_aui_detailpages00) .

The pictures below show the front and back side of one meter.



Figure 2.51 – Meter Front

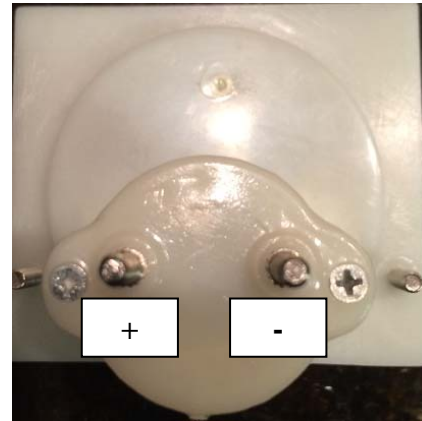

Figure 2.52 – Meter Back



## 2.6 Extra-Long .1” header Pins & Socket Cable

The Arduino Mega 2560 I/O on the rear of the controller is via a two row female .1” header. In order to connect to the Arduino Mega 2560 I/O header easily, I used the extra-long male header pins connected to 6 conductor .1 socket to socket cable.

The extra-long .1” header pins can be purchased at Adafruit.com  
<http://www.adafruit.com/products/400> .

The picture below shows the header pins.

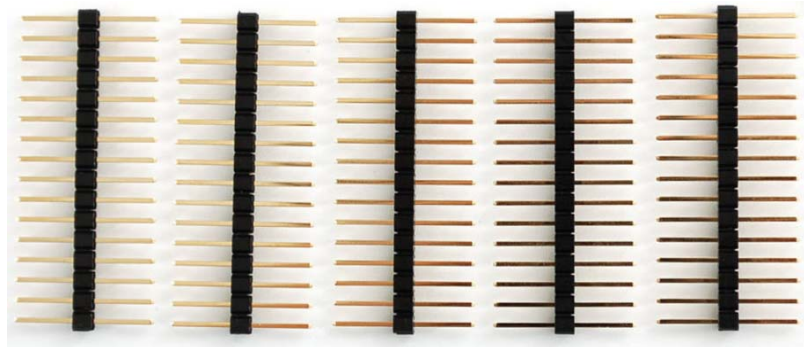

Figure 2.61 – Header Pins

The socket to socket cable can be purchased at Pololu.com  
<https://www.pololu.com/product/1239> .

The picture below shows the socket cable.



Figure 2.62 – Socket to Socket Cable



## 2.7 Ultraviolet LEDs

The glow in the dark components of the clock utilize ABS glow in the dark filament. While daylight will allow the glow in the dark filament to glow at night, we supercharge this effect by adding ultraviolet LEDs positioned near the gauges and the pushbutton assembly. The LEDs have a purple glow to them when they are on which provides a soothing lighting effect to the clock with the added bonus of charging the filament.

Each gauge utilizes (2) LEDs and the pushbutton assembly utilizes (4) LEDs.

The LEDs were purchased at Amazon.com [http://www.amazon.com/gp/product/B00TA4E2CY?psc=1&redirect=true&ref=od\\_aui\\_detailpages00](http://www.amazon.com/gp/product/B00TA4E2CY?psc=1&redirect=true&ref=od_aui_detailpages00). The LEDs have a resistor and wire leads attached to them. Since we need to control 12 LEDs, I used an NPN transistor driven by an Arduino Pin to control the current required. The LEDs are simply turn on or off via the LED rocker switch. Since the transistor is connected to a pin that allow PWM on the Arduino Mega 2560, you can ramp the LED brightness to any level with the existing hardware topology. You just need to write some code to do this if you choose.

The picture below shows the LEDs.



Figure 2.71 – Ultraviolet LEDs



## 2.8 Power Supply

I used the following power supply for the Arduino Mega 2560. The power supply was purchased at Adafruit.com <http://www.adafruit.com/products/63> .

The picture below shows the power supply that is used. Be sure to use at least a 9 volt DC power supply and not a 5 volt DC power supply. A 5 volt DC power supply does not provide the desired voltage for the project.



Figure 2.81 – Power Supply

## 2.9 Ring Terminals

I used the following AMP ring terminals to make the connection to the meters.

The AMP ring terminals were purchased at Home Depot.

The picture below shows the ring terminals that are used.



Figure 2.91 – Ring Terminals



## 2.10 Filament

The clock utilizes HIPS black filament and ABS glow in dark filament.

The black hips filament was purchased at Lulzbot.com  
<https://www.lulzbot.com/products/hips-3mm-filament-1kg-reel-esun> and the glow in the dark filament was also purchased at Lulzbot.com  
<https://www.lulzbot.com/products/hips-3mm-filament-1kg-reel-esun> .

The pictures below show the filament colors.



Figure 2.101 – Hips Black

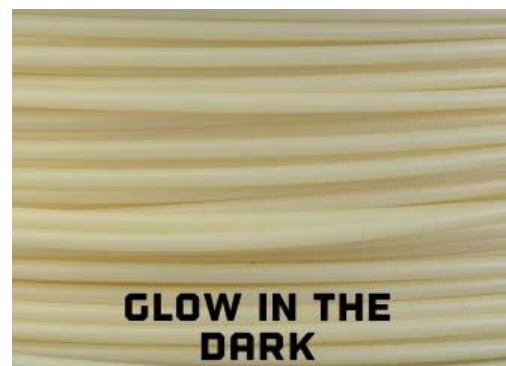

Figure 2.102 – ABS Glow in the Dark



## 2.11 Wire

I used the following wire for several connections.

The wire is standard twisted pair 22 awg battery wire. The wire was purchased at Servocity.com [https://www.servocity.com/html/battery\\_wire.html#.Vf9fIJftrbo](https://www.servocity.com/html/battery_wire.html#.Vf9fIJftrbo) .

The picture below shows the wire that I used.



Figure 2.111 – Twisted Pair Wire

The other wire type that I used is stranded 22 awg hookup wire. The wire was purchased at Pololu.com <https://www.pololu.com/category/139/stranded-wire>.

The picture below shows the wire that I used.



Figure 2.112 – Hookup Wire



## 2.12 Pushbuttons

The clock utilizes one momentary pushbutton for incrementing and decrementing the time based on the hour or minute rocker switch is selected. The clock also uses rocker switches for Talk (On/Off) and LEDs (On/Off).

The pushbutton and rocker switches were purchased on EBay and are shown below.



Figure 2.121 – Rocker Pushbuttons



Figure 2.122– Time Set Pushbutton

The rocker switches and pushbutton operate as follows:

### **Hour Set Rocker Switch**

The Hour rocker switch is active when the Blue LED is on. Do not place the hour and minute rocker to on at the same time. With the Hour LED on, change the hour setting by pressing the increment and decrement switch. The hour will cycle between 1 and 12. The AM/PM gauge will change based on the time set. If the gauge reads PM and you want AM, just press increment until the time passes 12 PM. Place the rocker switch in the off position once you have the desired hour setting.

### **Minute Set Rocker Switch**

The Minute rocker switch is active when the Blue LED is on. Do not place the hour and minute rocker to on at the same time. With the Minute LED on, change the minute setting by pressing the increment and decrement switch. Place the rocker switch in the off position once you have the desired minute setting.

### **Talk On Rocker Switch**

The Talk On rocker switch is active when the Green LED is on. With the rocker switch on, the time announcement will occur every half hour.

### **LED On Rocker Switch**

The LED On rocker switch is active when the Amber LED is on. With the rocker switch on, the ultraviolet LEDs will turn on.





**Set Time Increment/Decrement Rocker Pushbutton**

The rocker pushbutton is used to increment and decrement the hour or minute based on the rocker switch that is on.

**2.13 Paint**

The clock was painted with RUST-OLEUM textured paint (Black) purchased at Home Depot.



Figure 2.13– RUSTOLEUM Paint



## 2.14 Screws

I used #4 x 3/8 inch Philips pan head screws for mounting the bottom to the enclosure and the Arduino Mega to the bottom. The screws can be purchased at Home Depot or Lowes.



Figure 2.14 – Mounting Screws



### 3 Meter Gauge Decals / Design

The gauge for each meter was replaced. The standard gauge that came with the meter showed 0-5 VDC. I wanted to have (4) meters. The meters would show hours, minutes, seconds and AM/PM. The gauge scale plate for each meter was printed with the glow in the dark filament. The next step was to affix a professional looking gauge on the glow in the dark material that looked like it was a factory item.

To do this, I created gauge graphics and printed them on laser clear waterslide decal paper. The decal paper was purchased at Amazon.com <http://www.amazon.com/Papilio-Laser-Clear-Waterslide-sheets/dp/B005DFLVOG>.

Once the decals are printed, they are placed in water and then the decal is placed on the gauge glow in the dark scale plate that was printed. When all decals are affixed to the glow in the dark back plates, you will have the following:



Figure 3.1 – Gauge Scale plates with Decal

Note: I sprayed a clear lacquer on the front and sides of each back plate to ensure the decals stayed attached.



The attached PDF contains the artwork for the decals. You can just print this normally on 8.5" x 11" decal paper. I included gauge graphics with the Simpsons logo and without the logo.

**Gauge Graphics Without Logo**

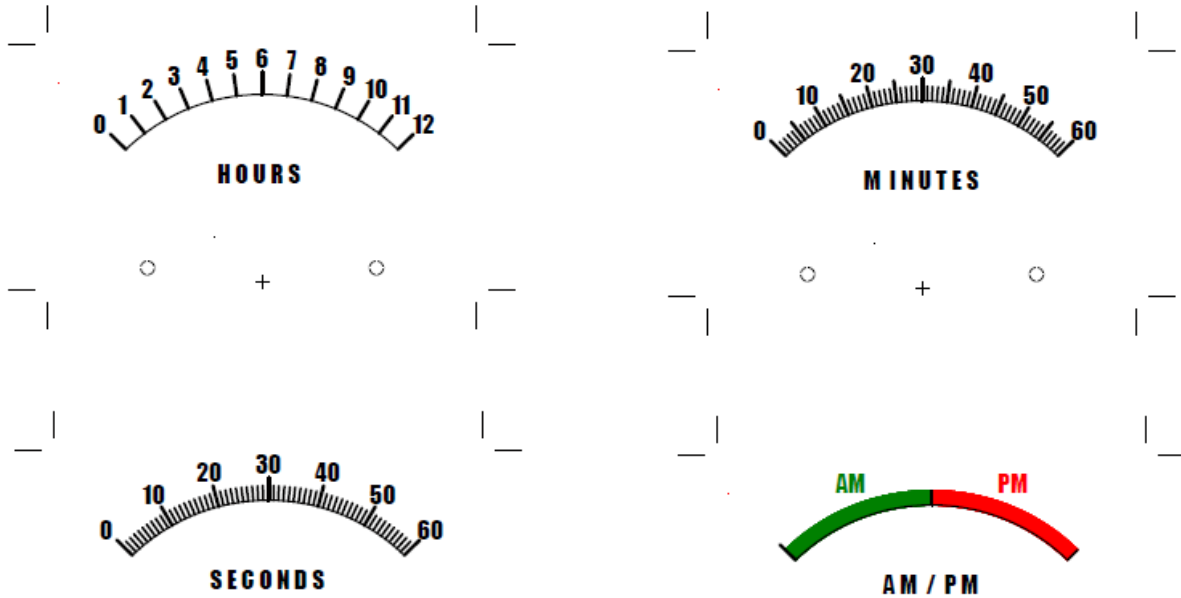

Figure 3.2 – Graphics without Logo

**Gauge Graphics With Logo**

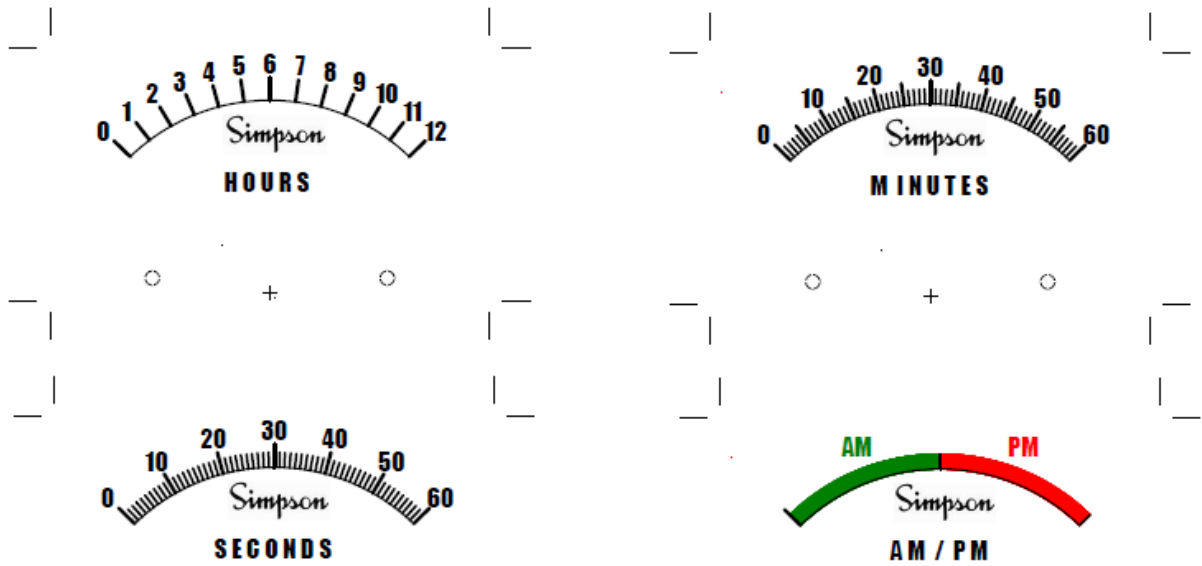

Figure 3.3 – Graphics with Logo



### **Graphic Design**

The gauge designs were created using a software package designed for just the purpose of creating gauge scale plates.

I used a software package called 'Meter' that can be obtained from <http://www.tonnesoftware.com/meter2.html> . The software is inexpensive and allows you to make any type of meter back plate you can think of.

At first I was using the typical graphic development software packages and thought that was going to take forever. This software allows you to focus on creative design and not get involved with the mechanics of drawing the angles correctly or spacing the numbers just right.



## 4 3D Printing

The entire clock was printed using a Lulzbot Mini 3D printer. I used HIPS material for printing all parts except the glow in the dark push button plate and the glow in the dark meter backs. The glow in the dark items were printed with ABS material.

The files are in .STL format and are as follows:

### **Meter Dial Plate.stl**

This file is the glow in the dark meter gauge plate that will replace the existing scale inside each meter. A total of (4) of these need to be printed. These are printed with glow in the dark ABS filament.

Decals will be placed on the plate that will provide the scale image.

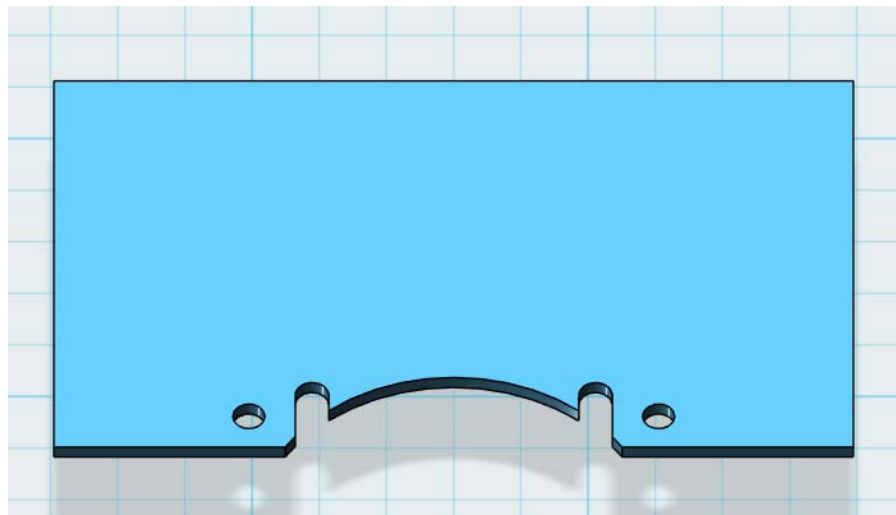

Figure 4.1 – Glow in the Dark Meter Gauge Plate



**Meter Front.stl**

This file is the front portion of the clock that the meters are mounted to. This is printed with black HIPS filament.

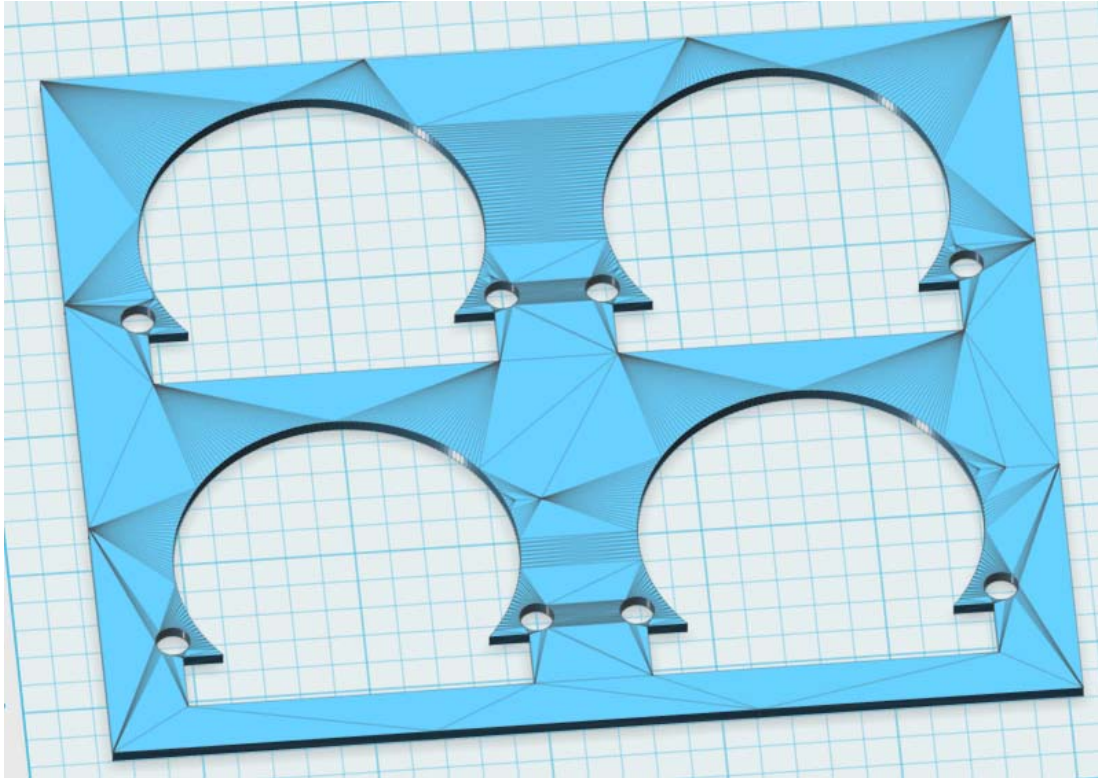

Figure 4.2 – Meter Front



**Meter Right.stl**

This file is the right side of the clock enclosure as you are facing the front of the clock. This is printed with black HIPS filament. The orientation of the print provides a smooth surface on the outside of the clock due to the heated printer bed.

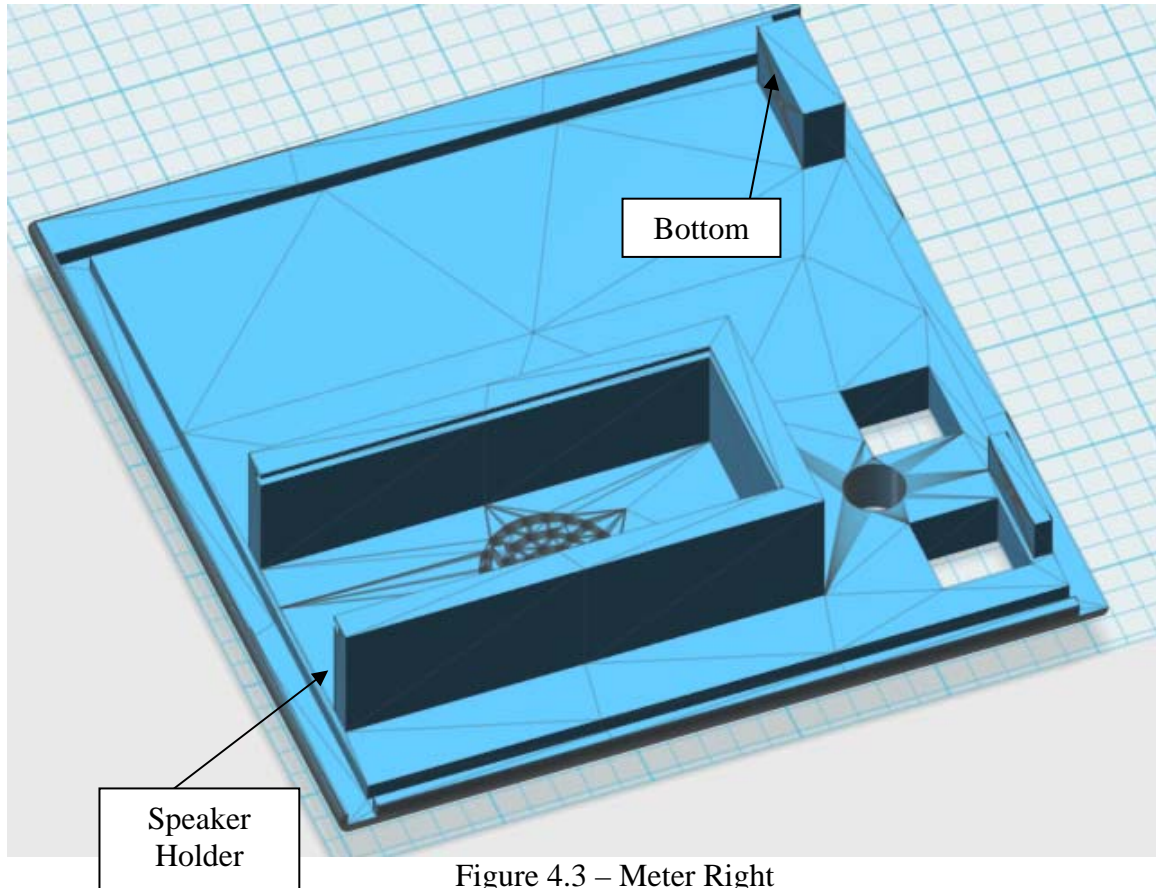

Figure 4.3 – Meter Right





**Meter Left.stl**

This file is the left side of the clock enclosure as you are facing the front of the clock. This is printed with black HIPS filament. The orientation of the print provides a smooth surface on the outside of the clock due to the heated printer bed.

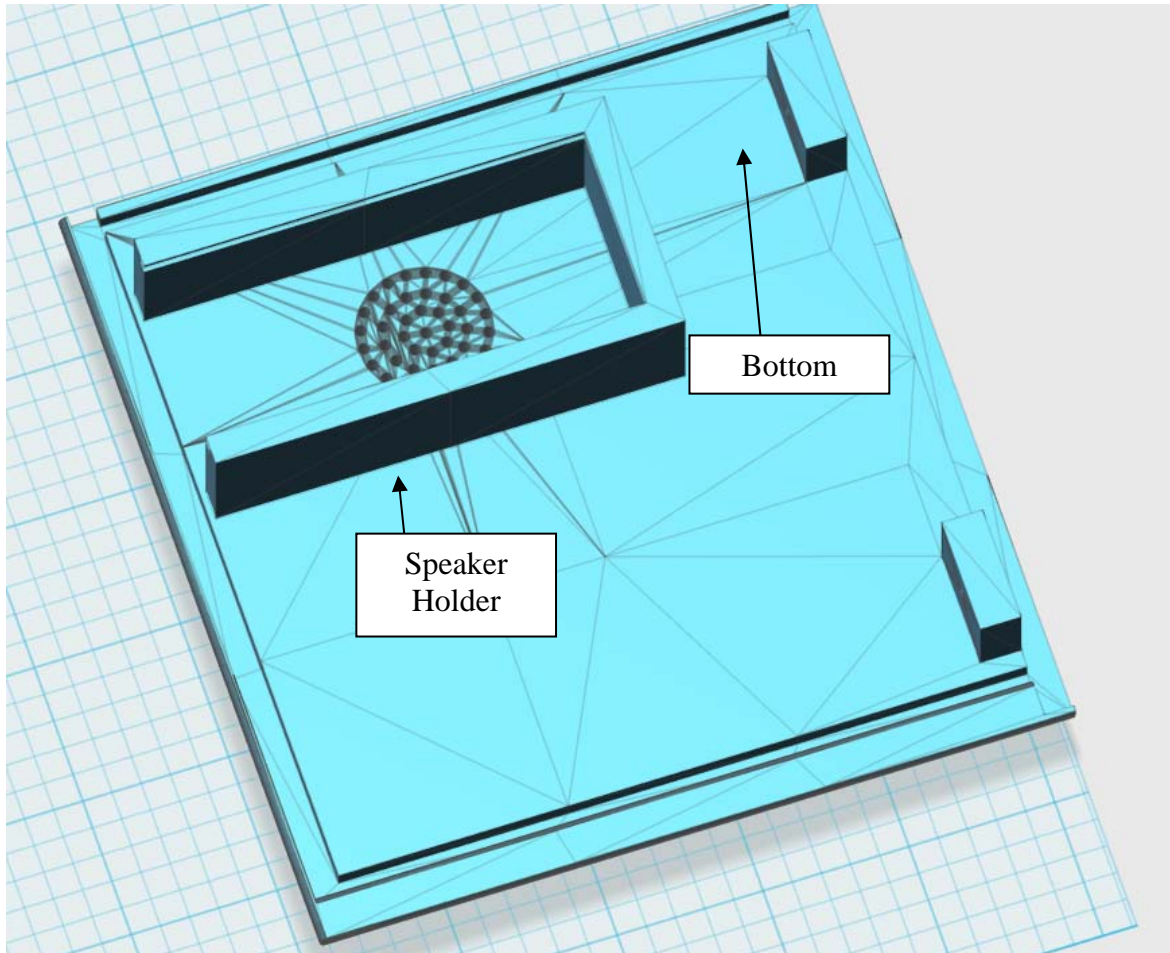

Figure 4.4 – Meter Left



**Meter Back.stl**

This file is the back side of the clock enclosure. This is printed with black HIPS filament.

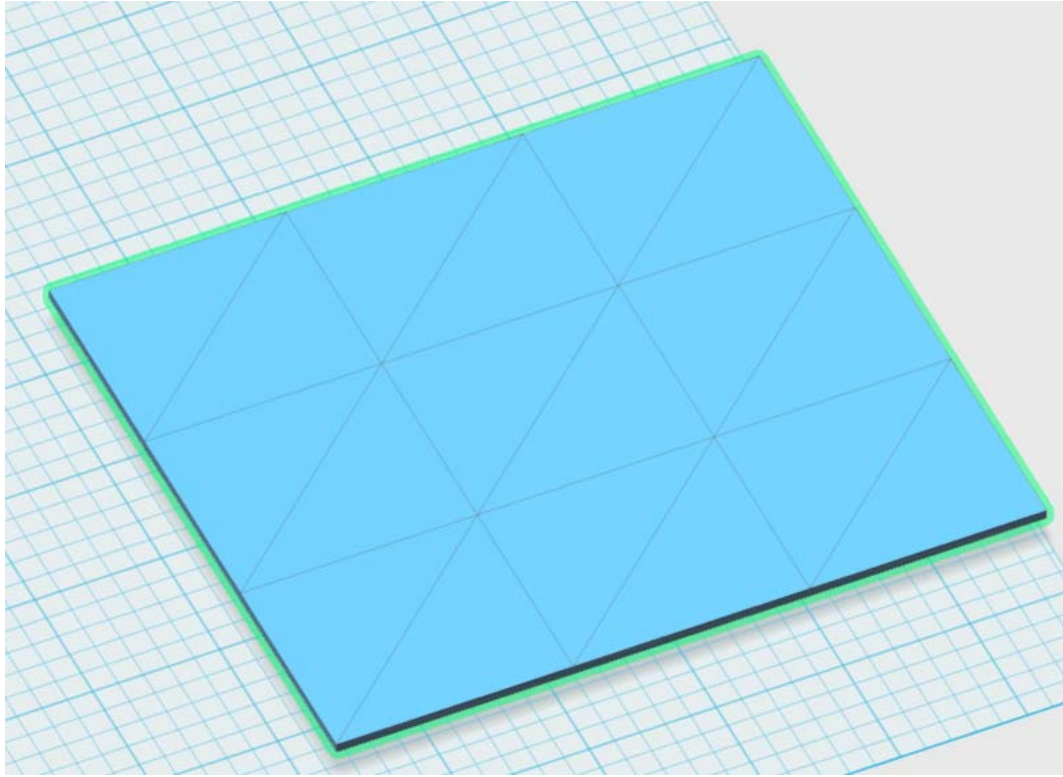

Figure 4.5 – Meter Back



**Meter Speaker Covers.stl**

This file contains the speaker covers. The covers slide into the channel on the speaker holders to prevent the speaker from falling out of the holder. These are printed with black HIPS filament.

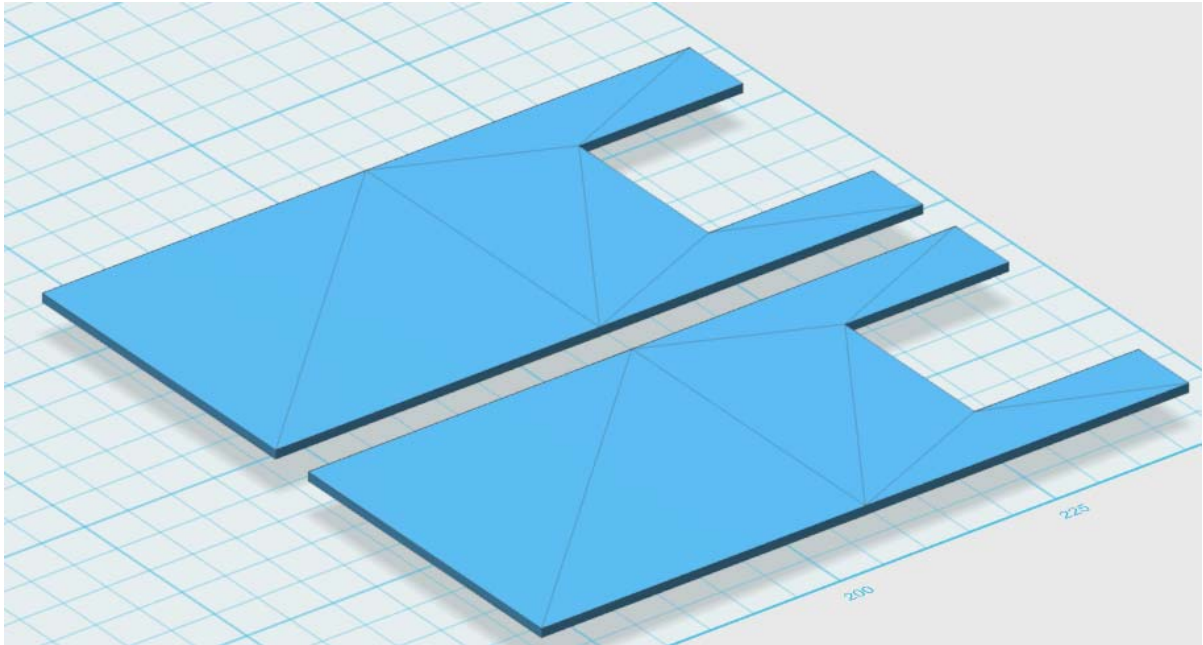

Figure 4.6 – Meter Speaker Covers



**Meter Bottom.stl**

This file is the bottom of the clock enclosure. The bottom is screwed onto the meter enclosure assembly so that you can access all components as required. The bottom is printed with black HIPS filament. The bottom includes screw hole mounting pilot holes as well as Arduino Mega 2560 mounting pads and holes.

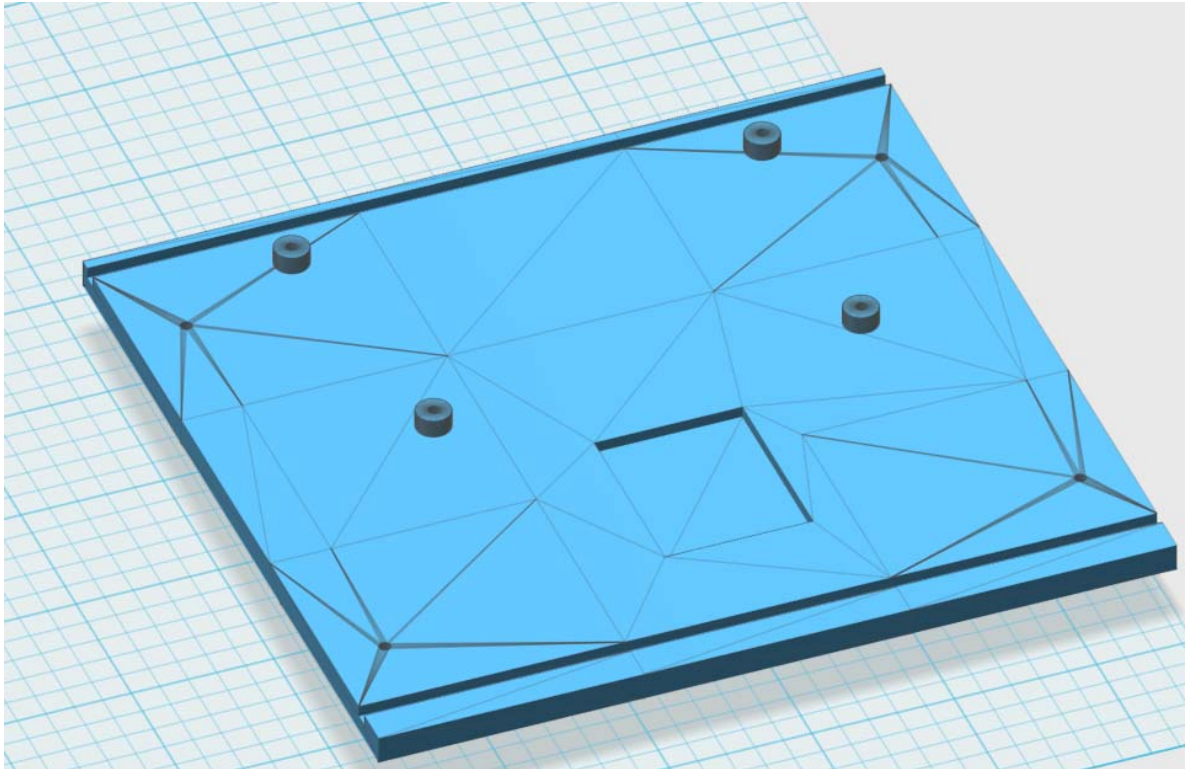

Figure 4.7 – Meter Bottom



**Meter Top.stl**

This file is the top of the clock enclosure. The large hole in the top will have the glow in the dark button assembly mounted on the top section. The top is printed with black HIPS filament.

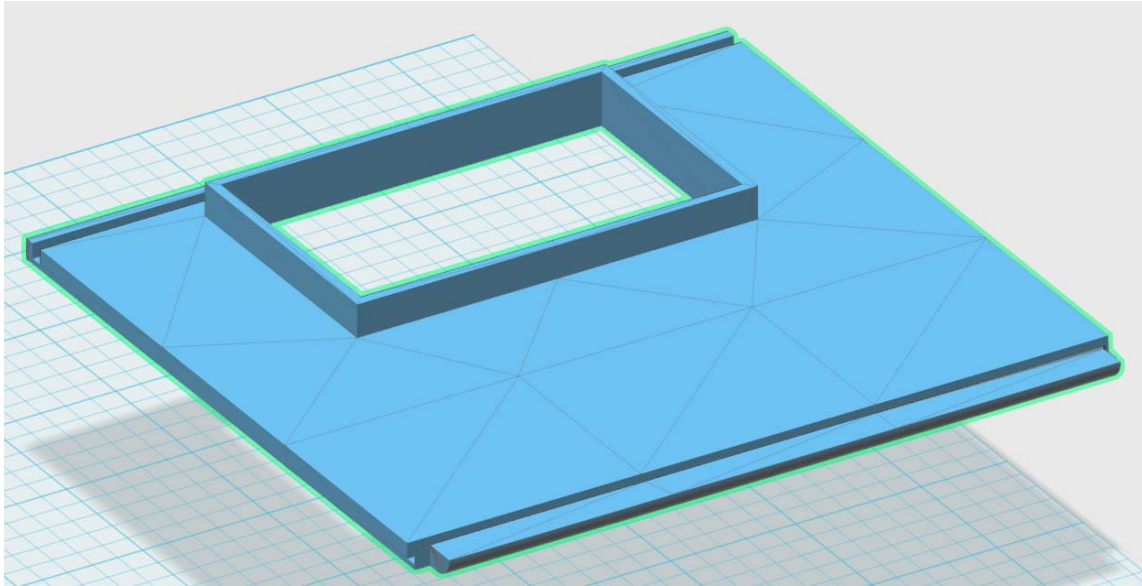

Figure 4.8 – Meter Top



**Meter Top Pushbutton Plate.stl**

This file is the pushbutton plate that inserts into the top. The top is printed with glow in the dark ABS filament.

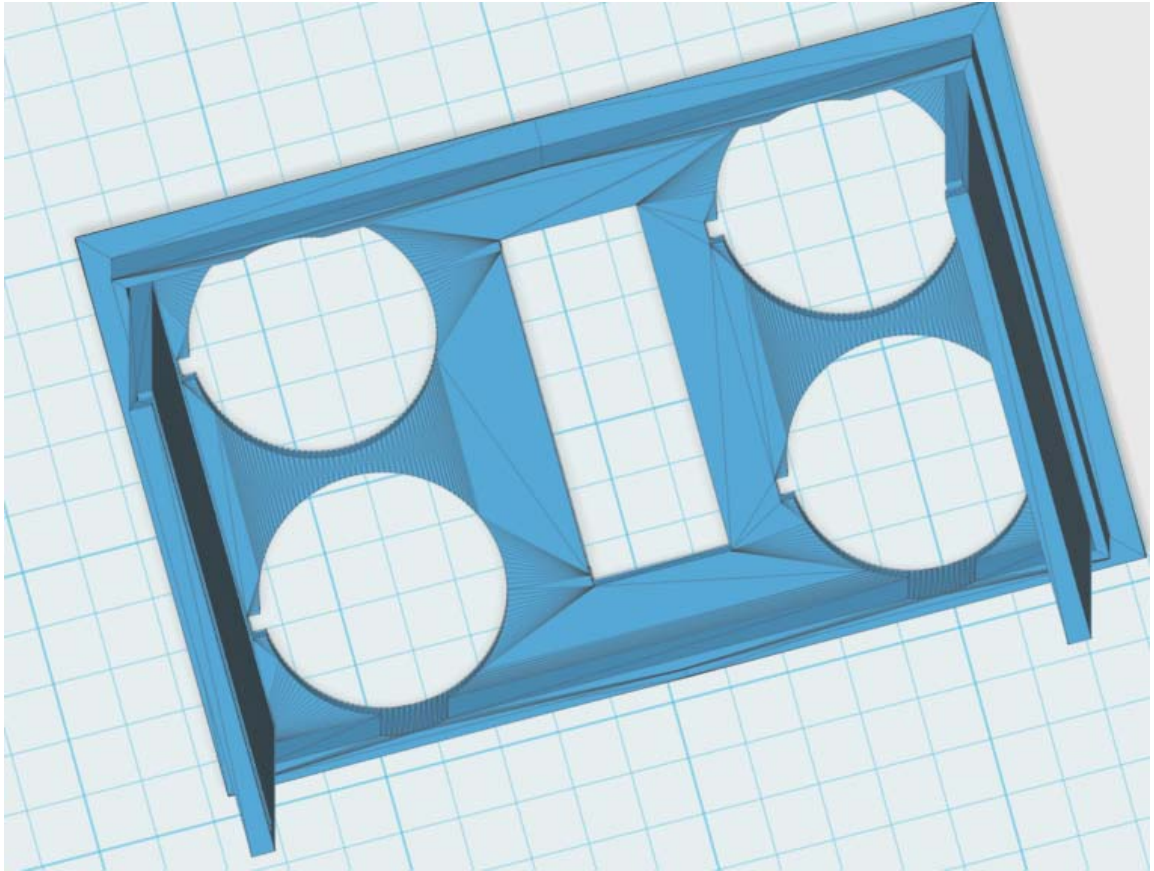

Figure 4.9 – Meter Top Button Plate Template



**Meter Top LED Holder.stl**

This file is the LED holder plate that slides into the pushbutton panel. Four 3 mm ultraviolet LEDs are mounted in this holder to light up the pushbutton panel.

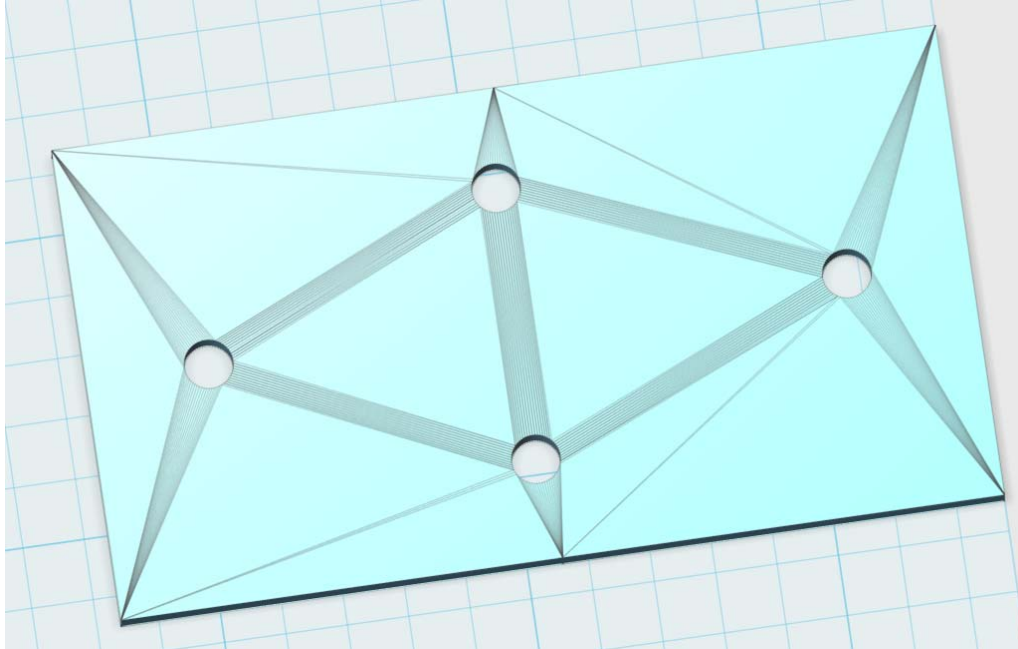

Figure 4.10 – Meter Top LED Holder



**Assembly View 1**

The picture below shows assembly view 1.

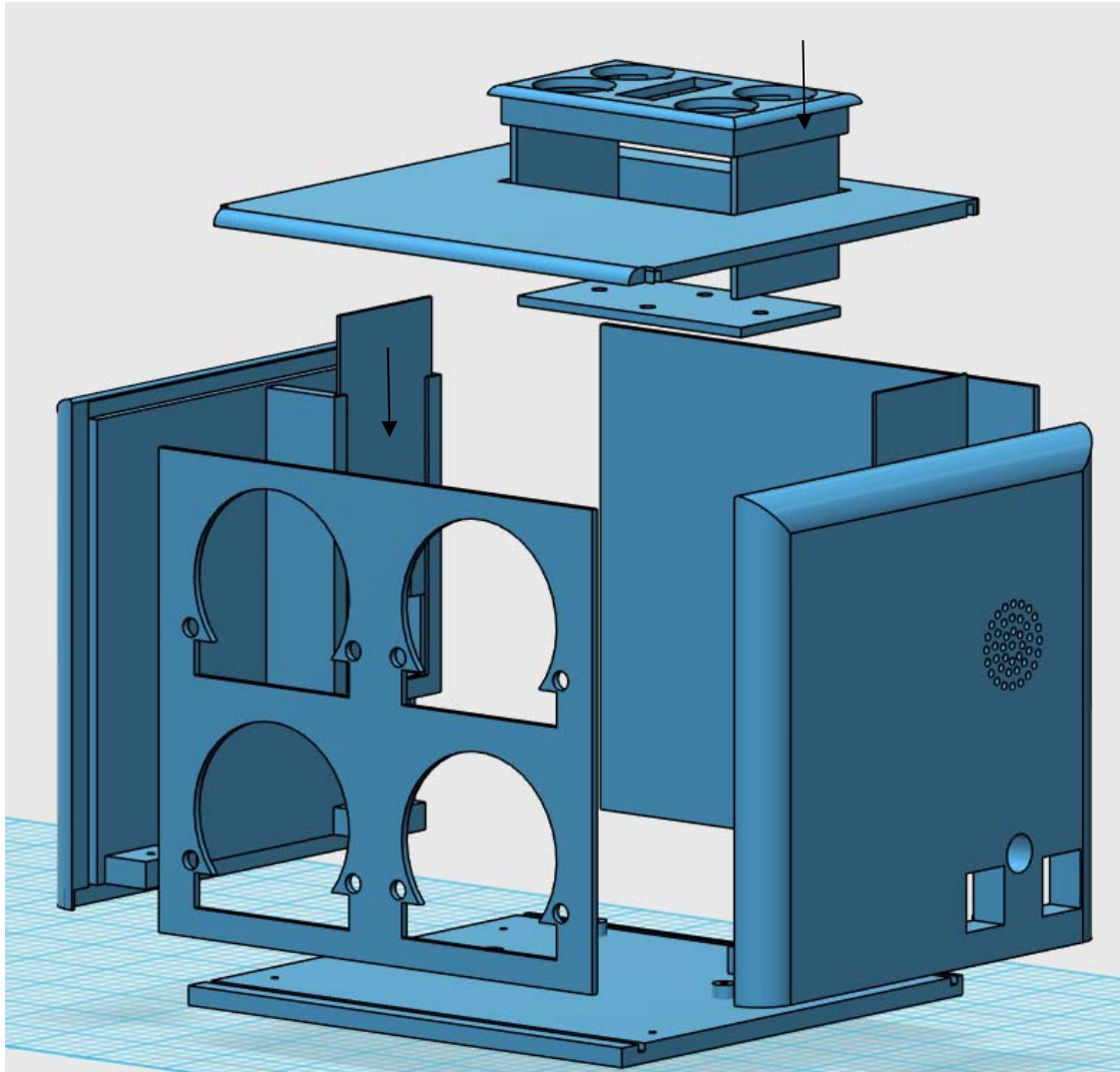

Figure 4.11 – Assembly View 1





**Assembly View 2**

The picture below shows assembly view 2.

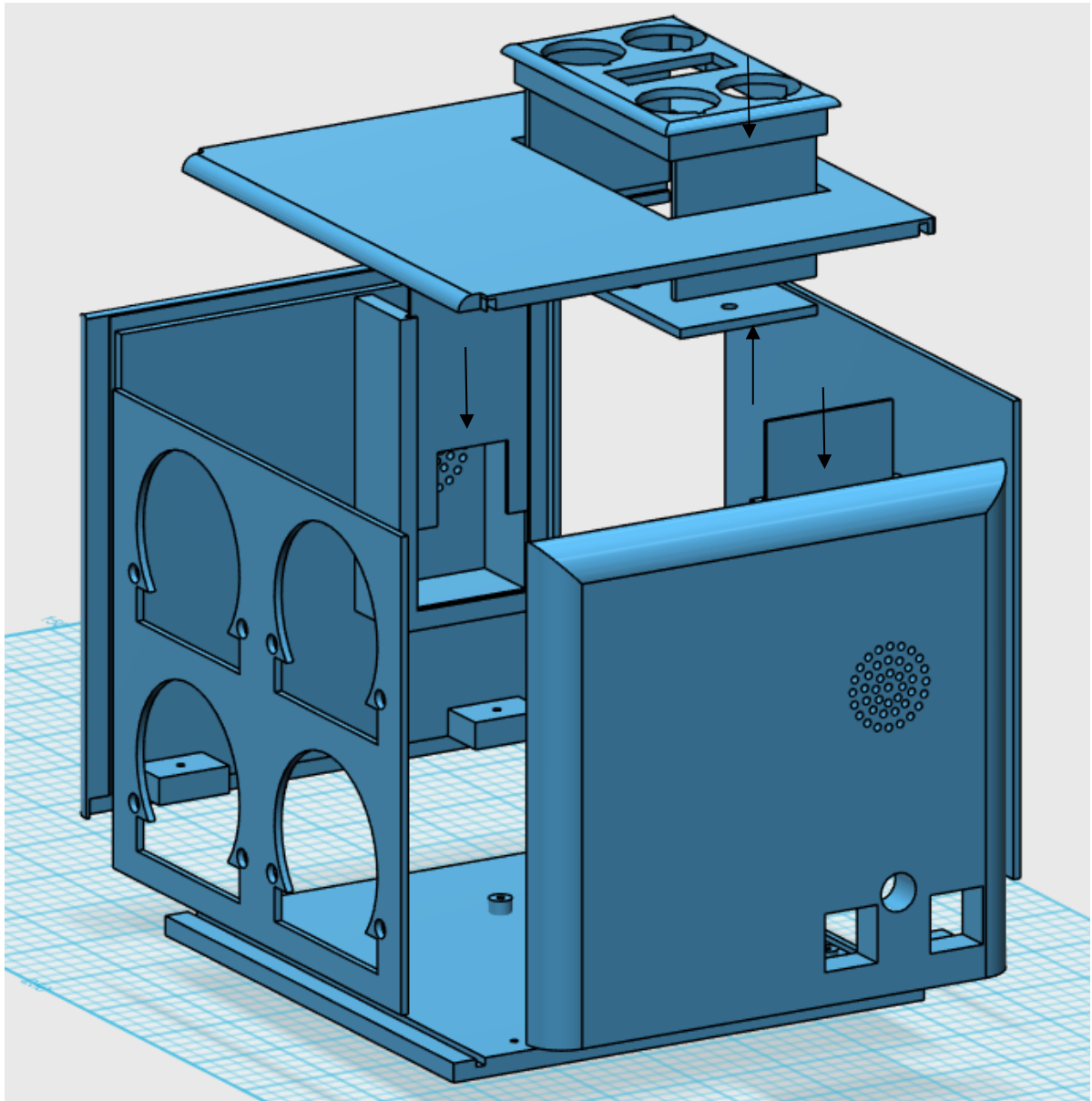

Figure 4.12 – Assembly View 2



**Assembly View 3**

The picture below shows assembly view 3.

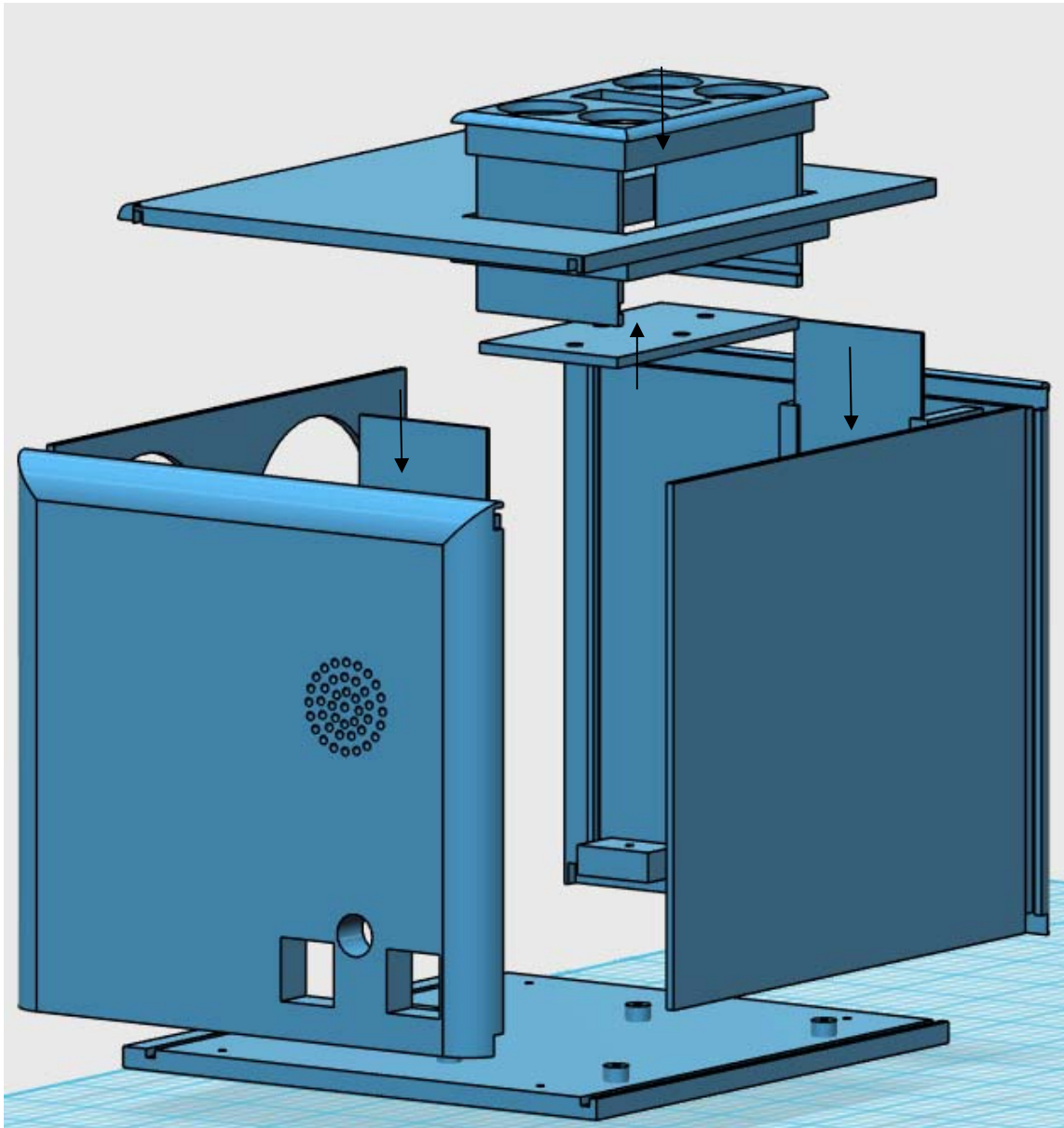

Figure 4.13 – Assembly View 3



**Assembly View 4**

The picture below shows assembly view 4.

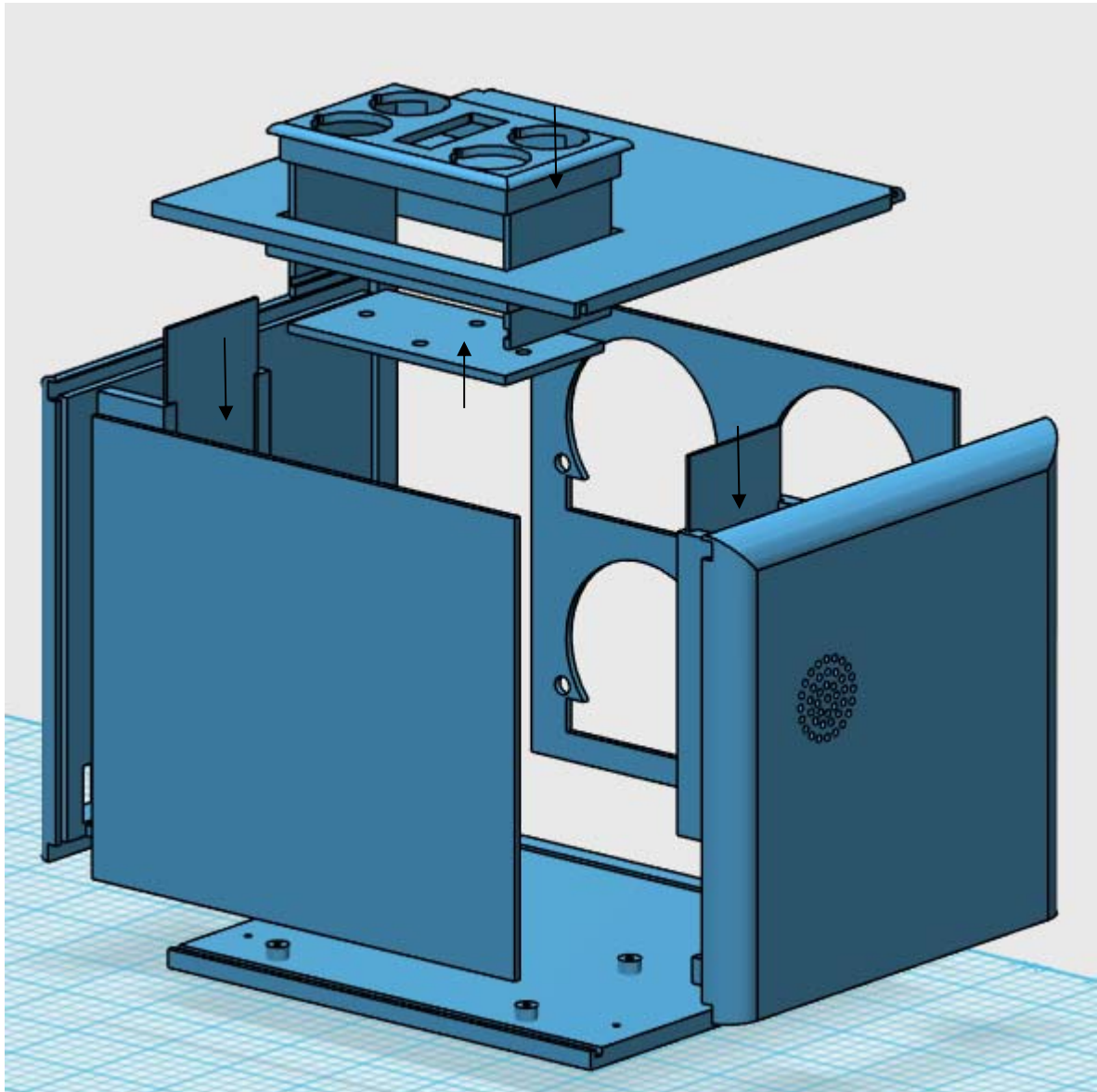

Figure 4.14 – Assembly View 4



**Assembly View 5**

The picture below shows assembly view 5.

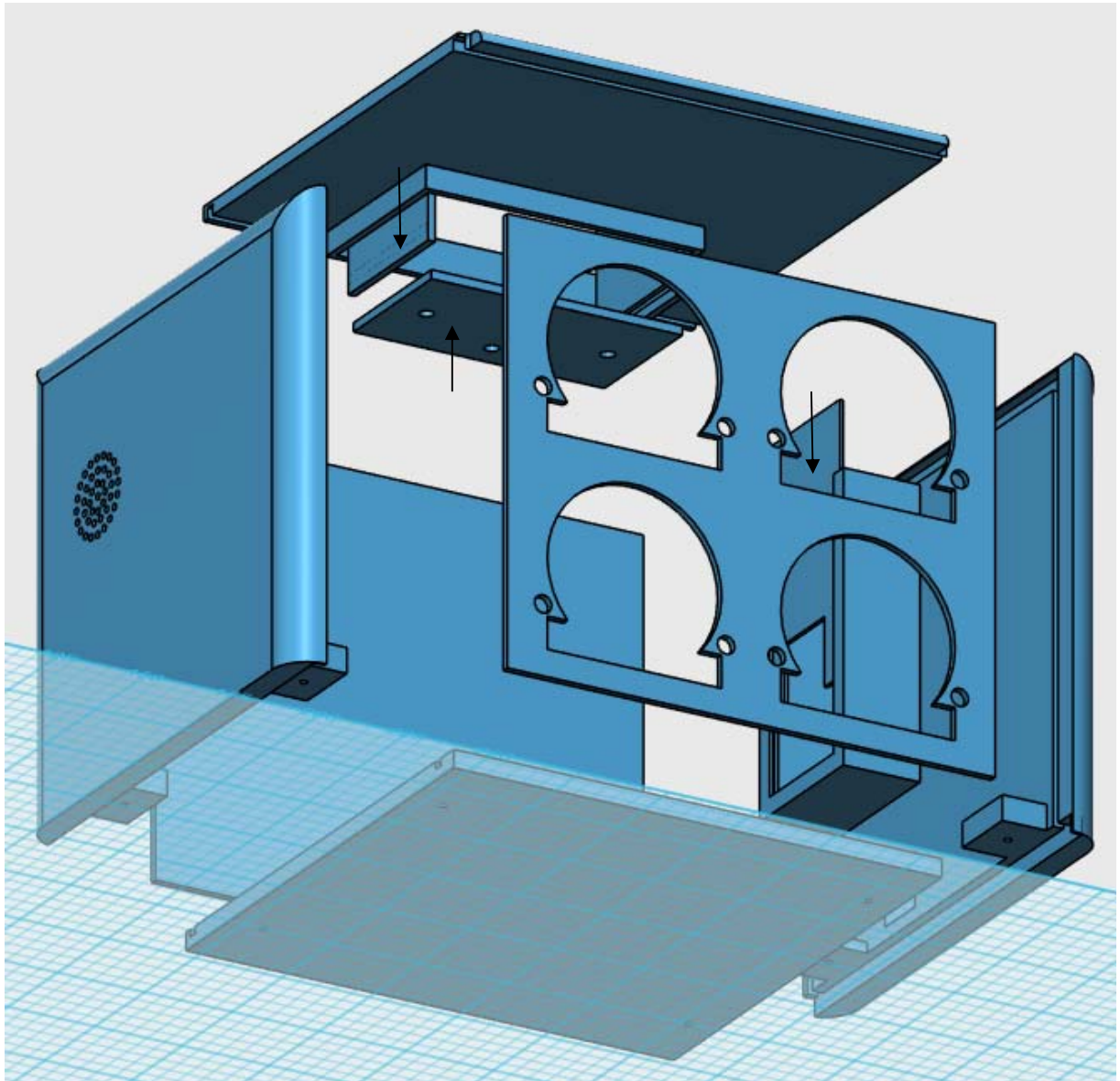

Figure 4.15 – Assembly View 5



## 5 Construction

Once the 3D parts are printed and the components have been gathered, it is time to start the build process. The following steps outline the assembly process.

### 5.1 Layout the Left and Right Sides

The left and right side walls are shown below. Lay the walls flat with the speaker holders facing you.

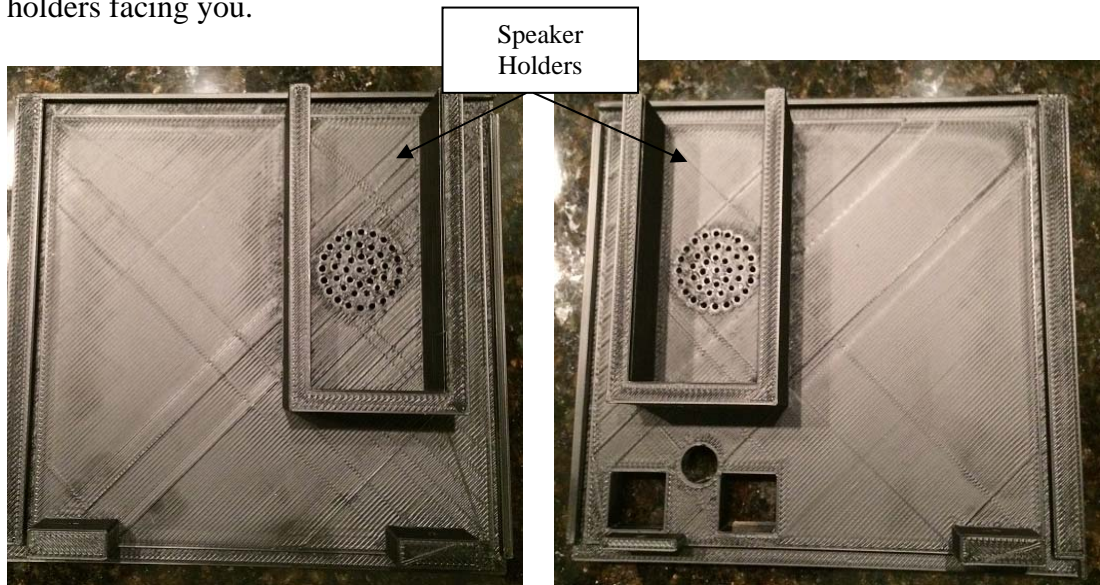

Figure 5.11 – Left Side Wall

Figure 5.12 –Right Side Wall



## 5.2 Insert the Speaker Covers

Insert the speaker covers as shown below. The cover will slide into the holder via the cover slots.

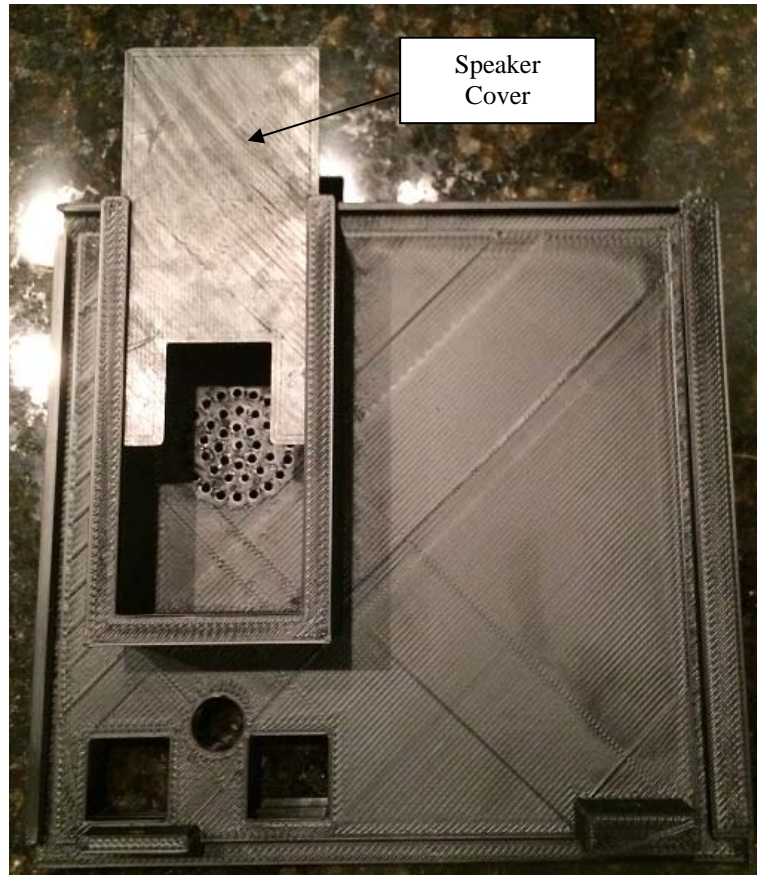

Figure 5.2 – Speaker Cover



### 5.3 Insert the Speakers

Slide the speaker into the holder as shown. Be sure you have the speaker wire protruding out of the hole in the cover.

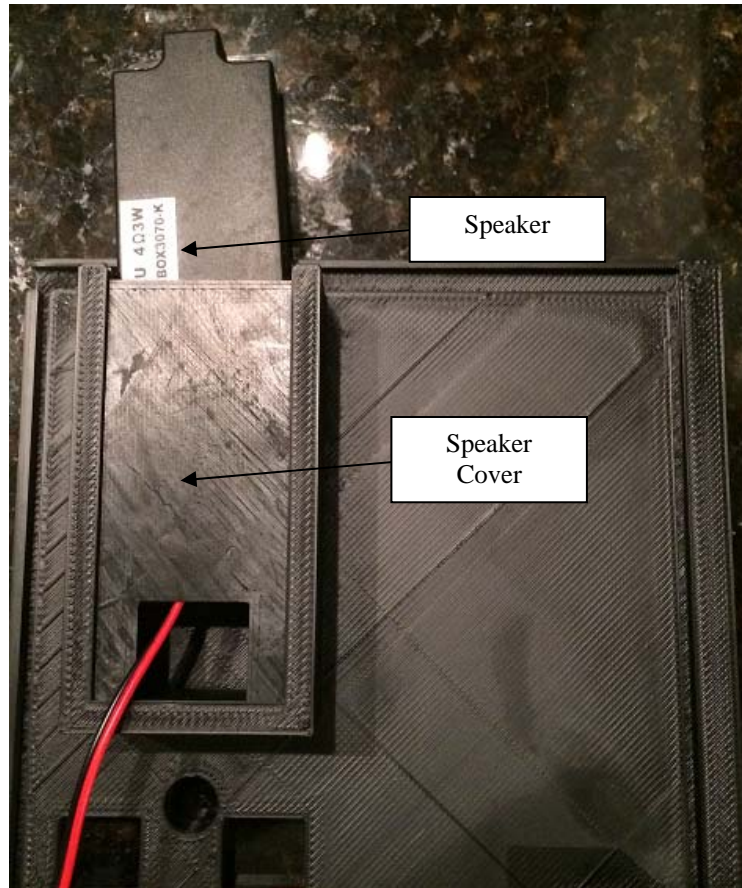

Figure 5.3 – Speaker and Speaker Cover



#### 5.4 Assemble the Enclosure

The smaller pictures shown below is with the clock assembly upside down. The sides and top must be assembled and glued together. As you can see, some painters tape was used to hold everything together during the gluing process.

The larger picture is shown with the clock enclosure right side up. Note that the front of the enclosure clock mounting holes should be located in a manner where the mounting holes are closest to the bottom of the enclosure.

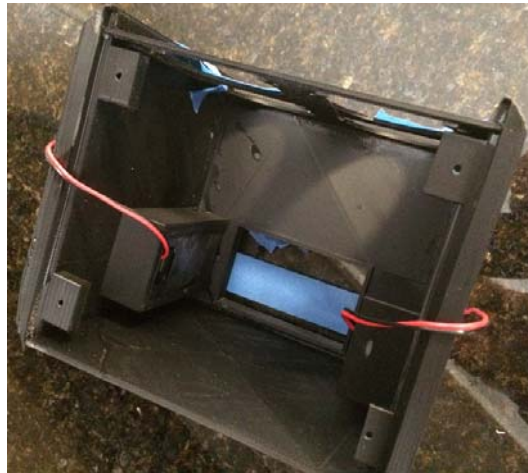

Figure 5.41 – Bottom View

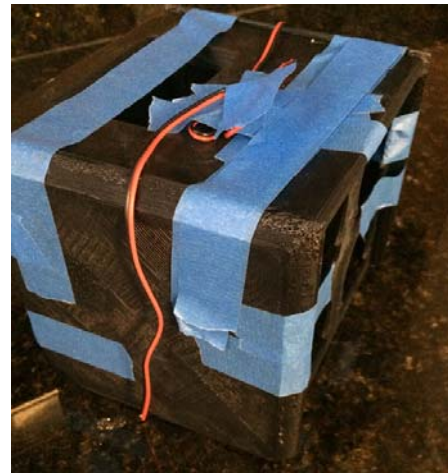

Figure 5.42 – Side View

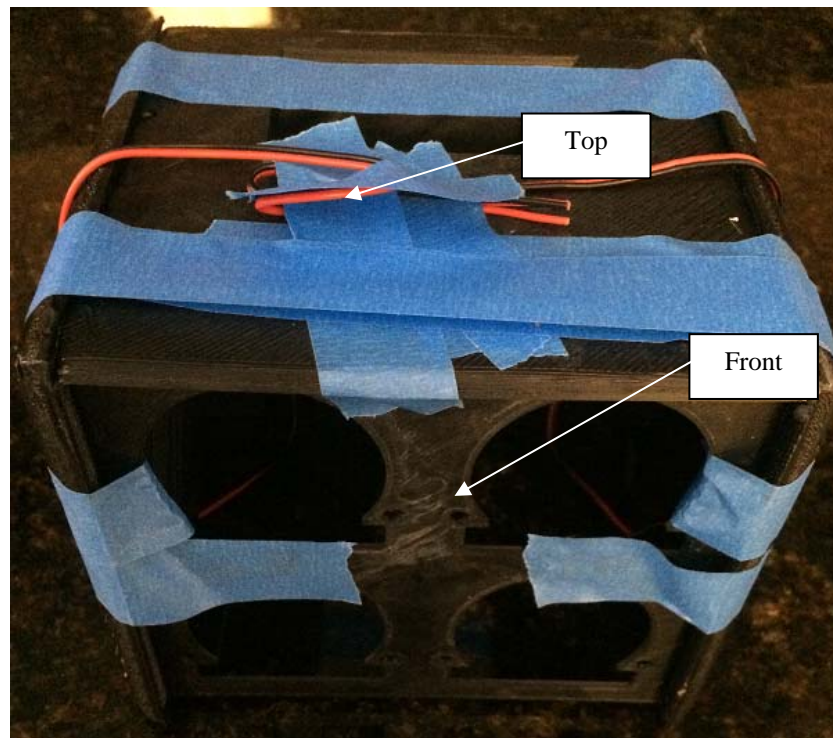

Figure 5.43 – Front Normal View





## 5.5 Glue the Enclosure

The enclosure is glued using SCIGRIP Weld-On 3 cement. The cement is a high strength water thin acrylic cement that dries quickly.

I used the SCIGRIP Weld-On 3 cement from Tapplastics.com

[http://www.tapplastics.com/product/repair\\_products/plastic\\_adhesives/weld\\_on\\_3\\_cement/131](http://www.tapplastics.com/product/repair_products/plastic_adhesives/weld_on_3_cement/131)



Figure 5.51 – Acrylic Cement

The cement is applied with a Syringe Hypodermic Applicator as shown below. I used the syringe from Tapplastics.com (SY20-65)

[http://www.tapplastics.com/product/repair\\_products/plastic\\_adhesives/hypo\\_type\\_solvent\\_cement\\_applicator/409](http://www.tapplastics.com/product/repair_products/plastic_adhesives/hypo_type_solvent_cement_applicator/409)



Figure 5.52 – Cement Applicator Syringe

The easy way to load the syringe is to remove the needle and pull up on the syringe shaft that is located in the polypropylene chamber with the needle end submersed in the cement canister. Once the syringe has cement in it, twist on the needle.

Turn the enclosure over and start applying glue to all of the seams. After 15 minutes the cement will have cured enough to remove the tape. Experiment with the cement on some scrap pieces of printed material. You will soon understand how the cement flows and the cure time involved.



### 5.6 Attach the Enclosure Bottom

Attach the bottom to the enclosure for painting and to get the alignment correct. You may notice the bottom does not fit flush due to the back or front sections are too long to allow the bottom to become flush. If this occurs, you can correct it by shaving of the front or back edge with the edge of a razor knife.

Once the fit is flush, use a 3/32" drill bit using the mounting holes as a guide to drill to slightly enlarge / clean out the existing holes. Be sure to go through the mounting tabs located on the left and right side panels. Once this is done, attach the four #4 x 3/8" pan head Philips screws.

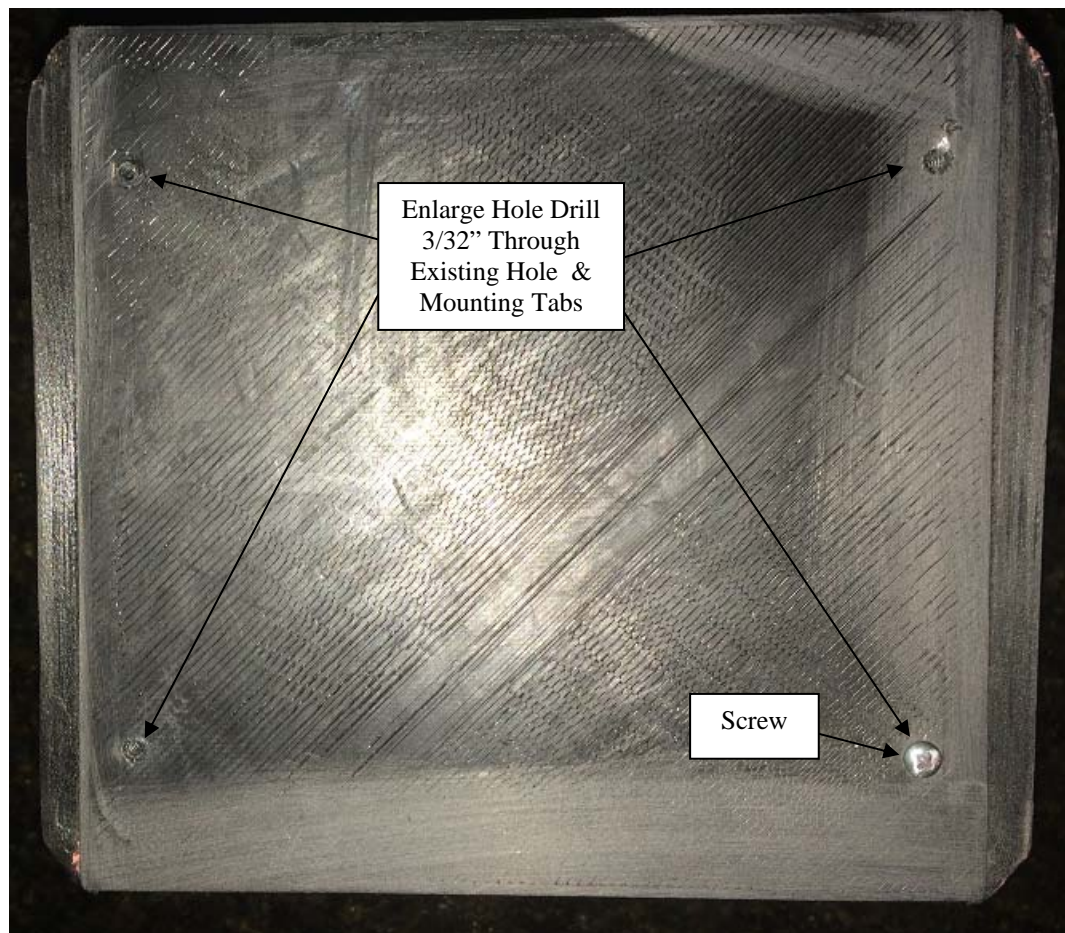

Figure 5.61 – Enclosure Bottom



### **5.7 Prepare the enclosure for painting**

Sand the enclosure. You will need to concentrate on the fillets that were created since they may not be perfect as shown below.

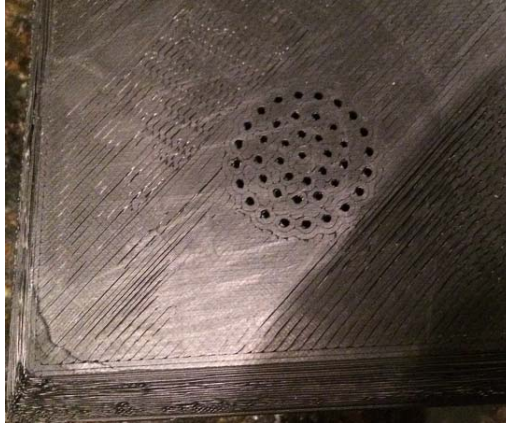

Figure 5.71 – Sanding & Blending Areas

After sanding, use Bondo glazing putty to fill areas that require filling/blending. Once the glazing dries (1 -2 hours), sand using 220 grit sandpaper. Repeat as required.



Figure 5.72 – Bondo Glazing Putty

Once you have filled imperfections, sanded and repeated the process, your clock enclosure will start to look like the picture below.



Figure 5.73 – Enclosure Preparation 1

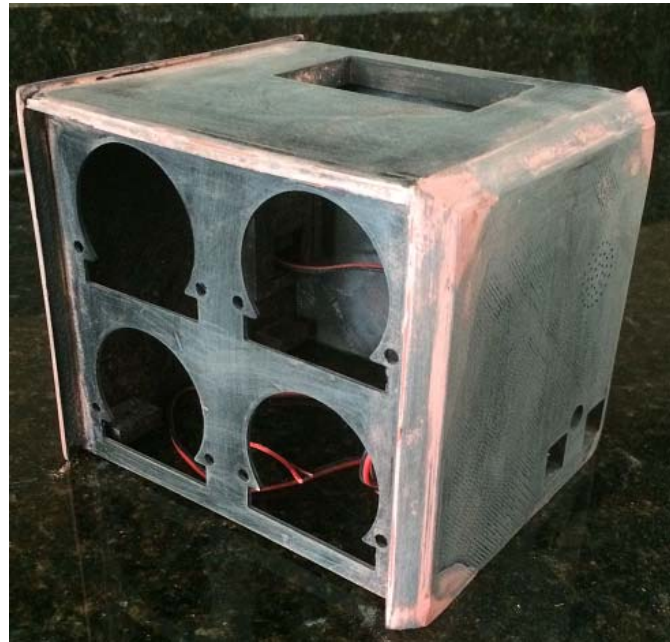

Figure 5.74 – Enclosure Preparation 2



## 5.8 Paint Enclosure

Wipe the enclosure down with tack cloth spray a coat of paint using the RUST-OLEUM black textured paint. After the first few coats, you can tell where you will need a little more body filler and sanding. Perform filling and sanding until you get things near perfect. This usually requires some spot painting to see what the results will be. Once you are happy, put on a few more coats of paint and let it all dry for three days.



Figure 5.81 – Paint

While you are waiting for paint to dry, you can work on getting the meters completed.



### 5.9 Prepare the Meters – Scale Plate & LED Holes

You should have (4) meter scale plates printed using the glow in the dark filament. The meter scale plates will look like the following:

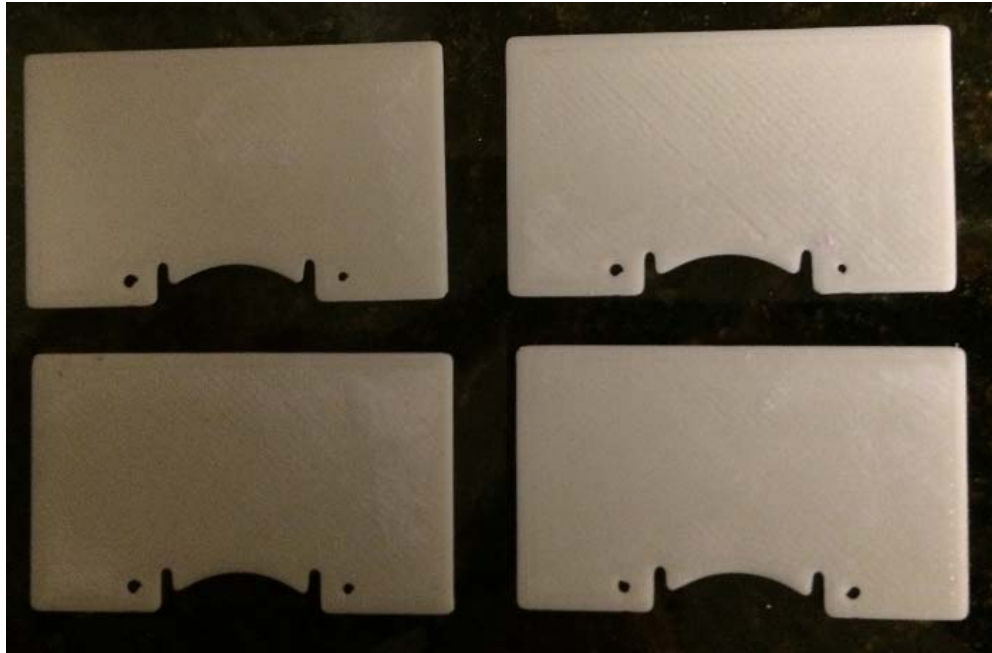

Figure 5.91 – Meter Scale plates

The next thing you need to do is create the decals. Using the attached PDF, print a decal sheet on the decal paper. Before cutting the decal sheet, print a few samples on regular paper.

Roughly cut each meter to be oversized from the paper sample you printed. Choosing a meter you just cut, trim the paper meter template so that is the correct size for the meter scale plate. Cutting just inside lines works well. The curved bottom section is removed using a razor knife. I hold the decal on the scale plate and flip the plate over. I then trace the curved outline and vertical pin slots on the decal. I then use a razor knife to trim the decal so it is a good fit for the scale plate.

Once you have mastered this process, do the same thing with each meter decal.



Insert a decal into a cup of water and after 45 seconds remove the decal and slide the clear portion of the decal on the meter scale plate. Adjust as required and used a damp paper towel to press the decal firmly on the meter scale plate. Complete this process for each decal.



Figure 5.92 – Scale Decal In Water



Once the scale plates have dried for a few hours. I sprayed lacquer on the front and side of each decal. The lacquer can be purchased at Lowes or Home Depot. The resultant meter scale plates should appear as follows:



Figure 5.93 – Lacquered Meter Scale plates



Figure 5.94 – Spray Lacquer





The next step is to begin the meter disassembly process. Remove the (2) Philips head screws as shown below:



Figure 5.95 – Meter Scale plates

Philips Head Screws

With the two screws removed, remove the clear meter cover. Once the clear meter cover is removed, remove the two small screws that hold the scale plate on as shown below:

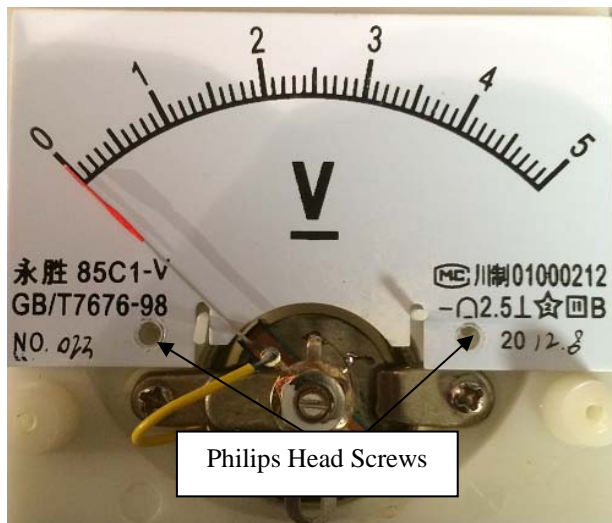

Figure 5.96 – Meter Scale plates

Philips Head Screws



With the screws removed, the scale plate slides upward. Slide the original scale off to remove. With the plate removed, the meter will now look like the following:

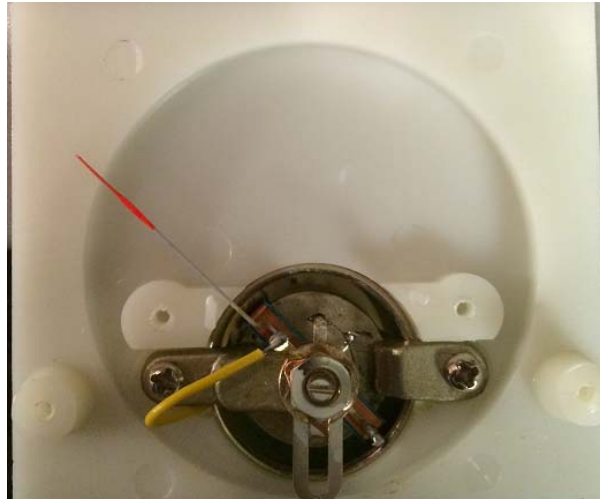

Figure 5.97 – Meter Scale plates

Now drill two holes to allow the 3 mm ultraviolet LEDs to be mounted.



Figure 5.98 – Meter Scale plates

LED holes

Use the existing indents where the holes are located as a drilling guideline.



Now install the new scale plate and cover in the reverse order that you removed everything.



Figure 5.99 – Mounting Pins / holes

Slide Down On Pins

The Decal Screw Hole Markers Usually Do Not Line Up. No Big Deal Since They Cannot Be Seen

Repeat the procedure for all meters.



Verify the meter needle will move freely across the range of the scale. To do this, touch the positive and negative leads of a battery holder with three AA batteries to the positive and negative terminal of the meter. If the needle swings in both directions without stopping, you are good to go. If not, you may need to bend the needle towards the clear cover slightly or bend the needle so it does not rub on the new meter plate.



### 5.10 Epoxy two LEDs to each meter

The assembled meter with the LED mounting holes is shown below. Two ultraviolet LEDs will be inserted into the holes and secured with epoxy. I found that putting a little epoxy around the hole before inserting the LED works well. Be sure not to get too much epoxy into the hole so it does not drip inside the meter faceplate. Once the LED is inserted, I add a little more epoxy around the LEDs.



Figure 5.101 – Rear of meter with LED mounting holes

Once I added the epoxy, I used painters tape to hold the LEDs in place until the epoxy cured. The meter assembly with the two LEDs and tape will look like the picture below. Make sure epoxy does not drip onto the clear cover since it will ruin the look. I did this once and replaced the clear meter cover from a spare meter

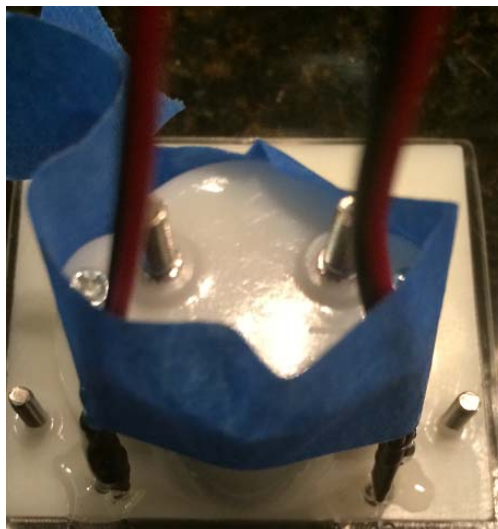

Figure 5.102 – Meter with LEDs held in place via tape



### 5.11 Prewire the Meters

Turn the meter over so the back is facing you. We are now going to wire the meter for needle movement and the LEDs. As a reference the picture below shows the back of the meter and the polarity.

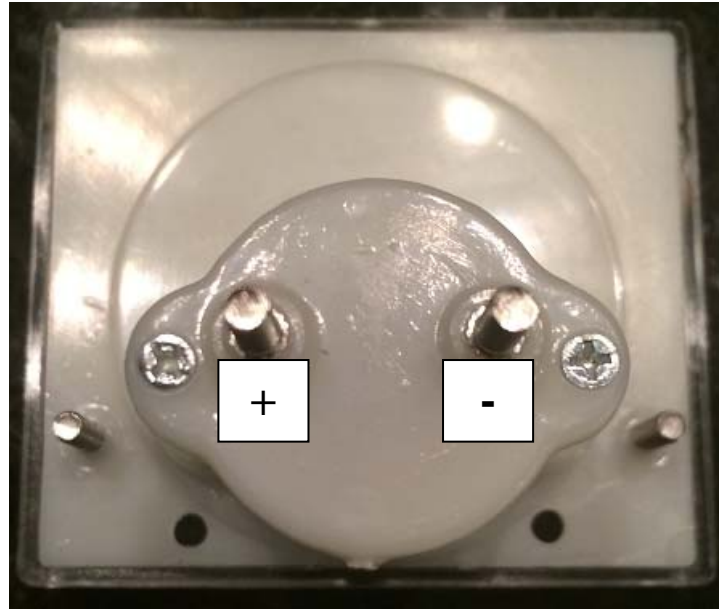

Figure 5.111 – Meter Polarity

Using the AMP ring terminals discussed previously, solder a red and black wire to their own ring connector.



Figure 5.112 – Ring Terminal Wiring



Connect the wires to the meter observing polarity. Use the included washers and nuts to make the ring terminal connection. The order of hardware I used is as follows:

- Flat washer
- Ring terminal
- Flat washer
- Split washer
- Nut



Figure 5.113 – Ring Terminals Installed

Repeat the procedure for all meters.



## 5.12 Prepare the Pushbutton Panel

Cut out the following letters from the decal sheet.

- Hour
- Minute
- Increment
- Decrement
- Talk On
- Talk Off
- LED On
- LED Off

Add some water to a dinner plate. The goal is to get the decal wet without losing it in a cup full of water since the labels are so small. Place the pushbutton plate in front of you.

Dip one of the decals in the water and after about 10 – 15 seconds the decal can be slid off the backing. Place the decal in the position shown below.



The labels are tiny and with my large man hands it was impossible to orient the label with my fingers. I used a small flat blade screwdriver to slide the label in the proper position once it was on the push button panel. If the label starts drying up, add a few drops of water on top of the label.



Be sure to check if your pushbutton detents are on the right or left side. I have seen both right and left detents. Just turn the cover 180 degrees from what is shown below if the detents are on the left hand side.



Figure 5.121 – Pushbutton Panel Labeling



Once all of the labels are on in the proper orientation, do not touch anything. Set the Pushbutton panel aside. After a few hours have passed, spray the pushbutton panel with five coats of clear lacquer. Lacquer dries fast so you can spray a coat, wait 10 minutes and repeat until complete. The spray lacquer step is important because the labels will easily come off without the lacquer.

With a nice lacquered pushbutton panel complete, go ahead and install the pushbutton and rocker switches as shown below. I used blue LED rocker switches for the hour and minute. I used a green LED rocker switch for Talk on/off function and an amber rocker switch for the LED on/off function.



**Warning:** Make sure to support the back of the pushbutton panel with your fingers when pushing in the rocker switches and the increment/decrement switch into the pushbutton panel holes to avoid cracking the pushbutton panel.



Figure 5.122 – Pushbutton Panel with Switches





### 5.13 Wire the Pushbutton Panel

Flip the pushbutton panel over and begin wiring each device.

- 1) Insert the 10 K ohm resistors between the gold and middle terminal on the rocker switches. I pushed the resistor through the hole on the rocker switch spade connector and bent the resistor lead up. I then soldered the resistor to the switch spade terminals and clipped the excess lead wire when I completed soldering.
- 2) Solder a black wire between each of the rocker switch gold spade connectors (one end of resistor is already on this terminal). Solder a black wire between the last rocker switch in you daisy chained to the center terminal of the increment / decrement switch.
- 3) Solder a 12” black wire from the center terminal of the increment/decrement switch. The end that is loose will be connected to on the Arduino ground connection terminal.
- 4) Solder a red wire between each of the rocker switch silver spade connectors at the end of each switch (Nothing connected to these terminals yet).
- 5) Solder a 12” red wire from last switch in the daisy chain. The end that is loose will be connected to 5 VDC on the Arduino 5 VDC connection terminal.
- 6) Cut one end of the 6 conductor cable shown below.



Figure 5.131 – 6 Conductor Cable

- 7) Strip back the insulation from the conductors on the cut end of the cable.



- 8) Solder the colored wire specified below to the center spade terminal of the specified rocker switch.

Red Wire – Hour Rocker Switch  
Yellow Wire – Minute Rocker Switch  
Green Wire – Talk Rocker Switch  
Blue Wire – LED Rocker Switch

- 9) Solder the colored wire specified below to the outside spade terminal of the specified increment / decrement switch position.

White Wire – Increment Position  
Black Wire – Decrement Position



Figure 5.132 – Pushbutton Panel Wired View



### 5.14 Epoxy the LEDs to the Pushbutton Panel LED Holder

The pushbutton LED holder is shown below. Four ultraviolet LED will be inserted into the holes and secured with epoxy.



Figure 5.141 – Pushbutton LED Holder

The pushbutton LED holder slides into the pushbutton panel as shown below.



Figure 5.142 – Pushbutton LED Holder Mounting

Insert the LEDs and use painter tape if necessary to hold them in position. Add a little epoxy over each LED to secure. When you are complete, the assembly should look like the following:

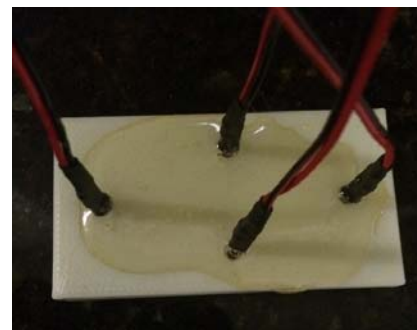

Figure 5.143 / Figure 5.144 – Pushbutton LED Holder Top and Bottom View



### 5.15 Solder the Ultraviolet LED leads

- 1) Insert the pushbutton panel onto the top of the enclosure.
- 2) Slide the LED pushbutton panel holder in the slots located on the pushbutton panel. I put a few drops of glue on the pushbutton LED panel holder so it does not move around.



Figure 5.151 – Pushbutton Panel

Slide or snap in the LED holder into the slots on the pushbutton panel with LEDs facing the pushbuttons.

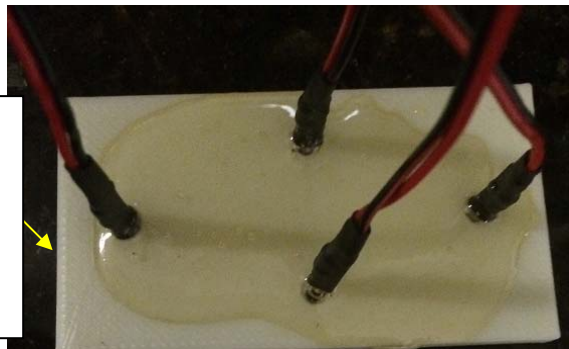

Figure 5.152 – Pushbutton LED Holder

- 3) Combine the 12 red ultraviolet lead leads and solder a red wire to the bundle of red wires for connection to 5 VDC power.
- 4) Combine the 12 black ultraviolet lead leads and solder a black wire to the bundle of black wires for connection to the transistor led.



Cut the wires to a manageable length and use heat shrink where possible to maintain a professional result.



When everything is assembled and complete, the goal is to have the ultraviolet LEDs backlight the pushbutton panel as shown below:



Figure 5.153 – Pushbutton Panel with LEDs On



### 5.16 Assemble Music Maker

Assemble the music maker per the instructions listed at [Adafruit.com](http://Adafruit.com). Be sure to solder the +12db jumper shown below to provide the clock with an acceptable volume level.

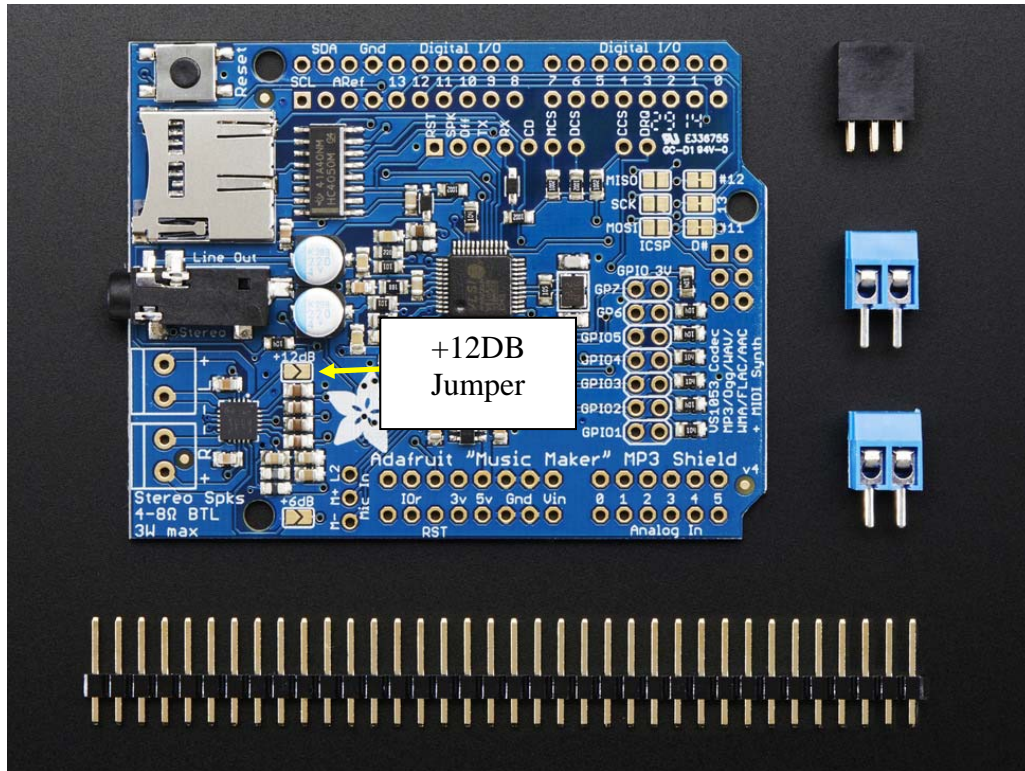

Figure 5.161 – Pushbutton LED Holder Mounting

Note: I used the stackable headers as shown below instead of the header pins that came as part of the music maker kit. This is required to utilize the 6 conductor cable attachment method.

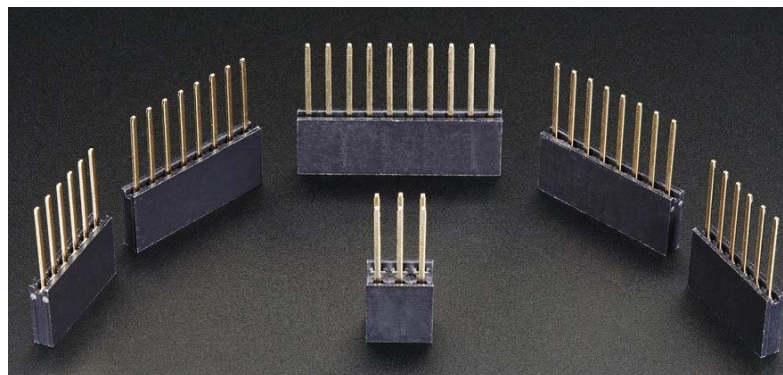

Figure 5.162 – Stacking Headers



### 5.17 Assemble DS1307

Assemble the DS1307 per the instructions listed at [Adafruit.com](http://adafruit.com). I soldered the header so that it faces upwards and be connected with connectors. I used one end of a servo extension cable for the connection.

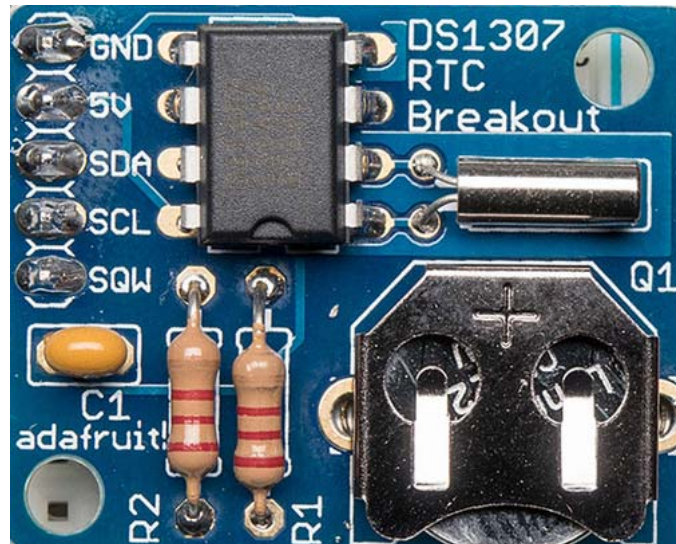

Figure 5.171 – DS1307 Real Time Clock



### 5.18 Make Arduino Wire Connections

Make the Arduino connections as shown on the wiring diagram. The connections were made with long header pins and the cables specified previously. An example of the wiring is shown below.

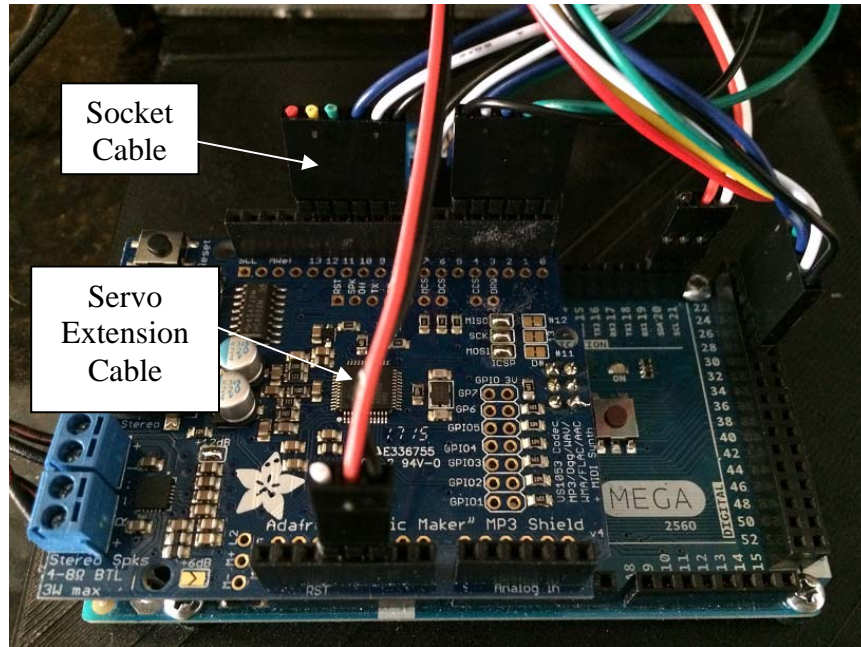

Figure 5.181 – Arduino Header Connections

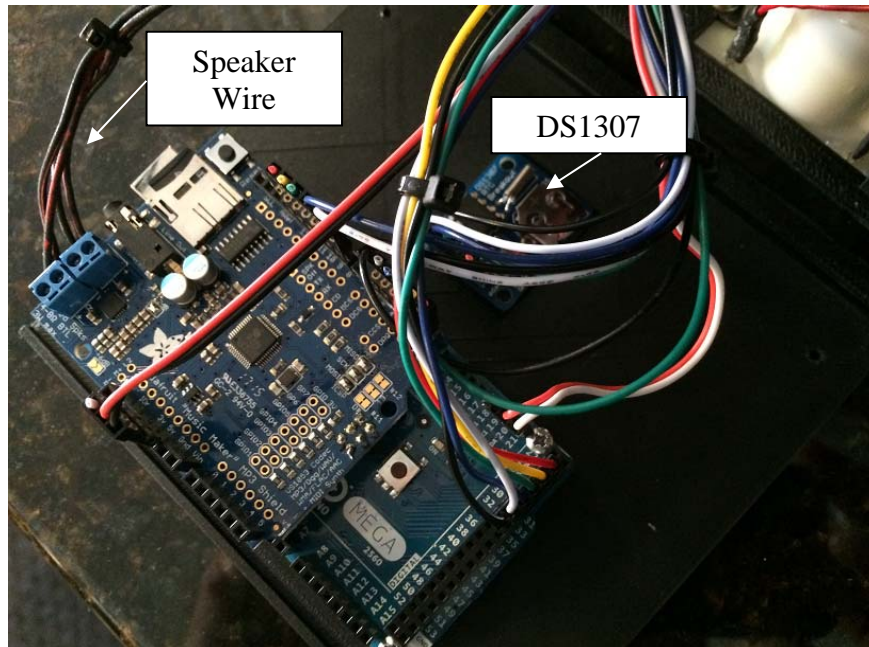

Figure 5.182 – Arduino Wiring





### 5.19 Wiring Diagram

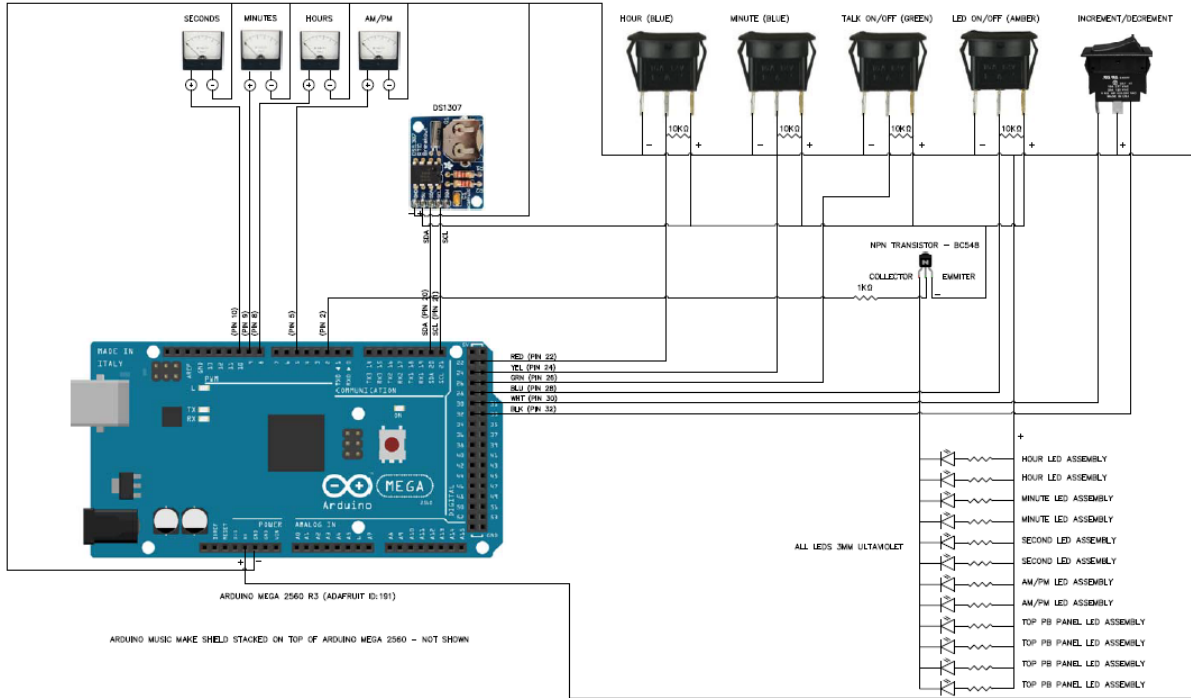

Figure 5.191 – Wiring Diagram



## 5.20 Program Arduino and Attach Base / Bumpers

Program the Arduino and verify proper operation. Once everything is working properly, you can attach the base. Bumpers should be installed to prevent the clock from scratching furniture. Small #4 phillips pan machine screws were used to install the base.

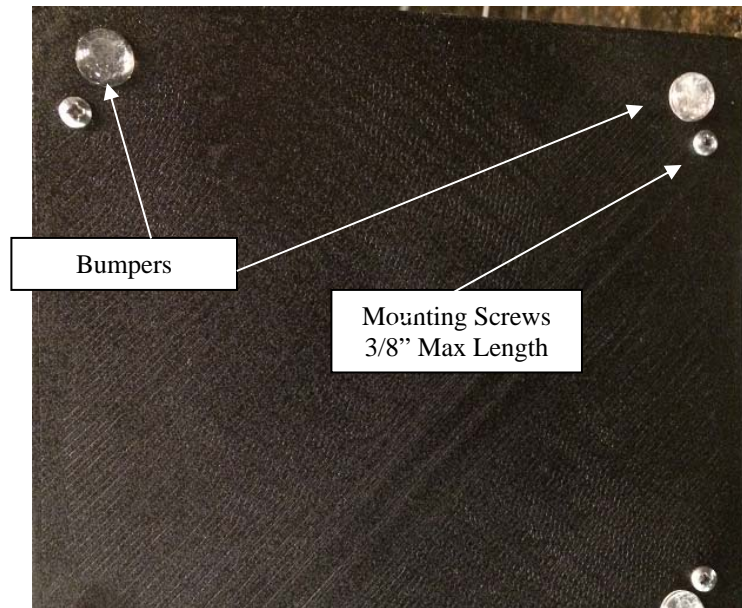

Figure 5.201 – Mounting Base Plate / Bumpers



Figure 5.202 – Mounting Screws



## 6 Example Time Display

The time shown below is 4:16 AM and 53 seconds.



Figure 6.1 – Time Example 1

The time shown below is 7:29 PM and 32 seconds.

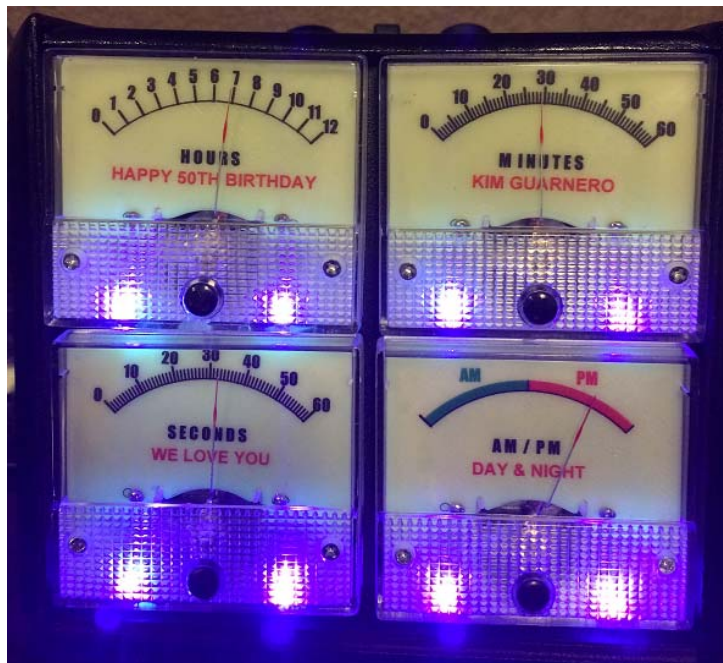

Figure 6.2 – Time Example 2



## 7 Variations

I made this clock for my wife as one of her 50<sup>th</sup> birthday presents. Since she is an electrical engineer, she appreciates the meters. The meter faceplates have a nice message on them. As a bonus, the kids reordered a message that is played whenever the clock is powered up.

I have included a power on message but you can modify the power on message and time announcement audio tracks to customize the clock and make it your own. Here are a few ideas that you can use to personalize the clock:

- At certain times of the day have the clock say different things such as:
- “your wife/husband name” is so sweet, 4 out of 5 dentists suggest flossing when in their presence.
- Is the time advancing? “your wife/husband name” does not seem to be aging
- My creator is such an intelligent lifeform

As you can see, the possibilities are endless. If you want to modify the power on message, just modify the audio file named Powerup.mp3.

The clock I gave as a present to my wife is shown below.



Figure 7.1/7.2 – Variation Examples

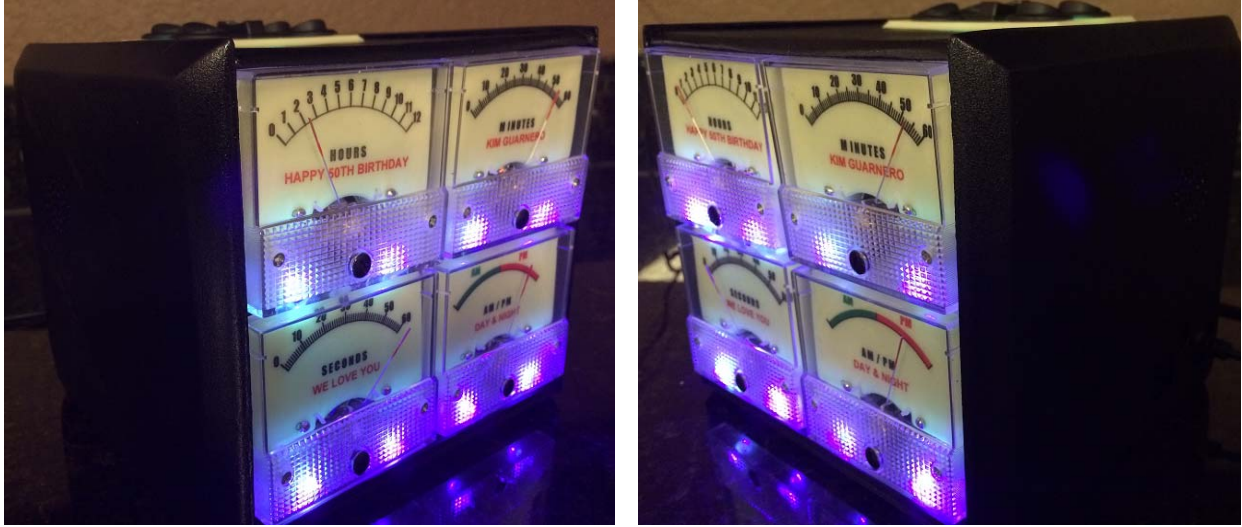

Figure 7.3/7.4 – Variation Examples



## 8 Parts Listing

The parts listed below were used to make the clock.

Description	Purchased	Part #	Qty
Arduino Mega 2560	Adafruit.com	Product ID: 191	1
Adafruit "Music Maker" MP3 Shield for Arduino w/3W Stereo Amp - v1.0	Adafruit.com	Product ID: 1788	1
DS1307 Real Time Clock	Adafruit.com	Product ID: 264	1
Stereo Enclosed Speaker Set - 3W 4 Ohm	Adafruit.com	Product ID: 1669	1
Extra-long break-away 0.1" 16-pin strip male header (5 pieces)	Adafruit.com	Product ID: 400	1
Shield stacking headers for Arduino (R3 Compatible)	Adafruit.com	Product ID: 85	1
6 conductor cable 6x1 F-F 12" Cable for ShiftBrites and ShiftBars	Pololu.com	Item #: 1239 <a href="https://www.pololu.com/product/1239">https://www.pololu.com/product/1239</a>	1
Direct Current 0-5 V White Voltmeter Analog Panel Meter	Amazon.com	<a href="http://www.amazon.com/dp/B0051E8ONA/ref=pe_1763890_145_073580_tnp_emaildp_1">http://www.amazon.com/dp/B0051E8ONA/ref=pe_1763890_145_073580_tnp_emaildp_1</a>	1
Papilio Laser Clear Waterslide Decal Paper 10 sheets	Amazon.com	<a href="http://www.amazon.com/Papilio-Laser-Clear-Waterslide-sheets/dp/B005DFLV0G">http://www.amazon.com/Papilio-Laser-Clear-Waterslide-sheets/dp/B005DFLV0G</a>	1



**Analog Talking Glow in the Dark 3D Printed Clock  
Construction Information**

<b>Description</b>	<b>Purchased</b>	<b>Part #</b>	<b>Qty</b>
Paint	Home Depot	Rustoleum Textured Black	1
Screws	Home Depot	Flat head Philips #4 x 3/4 inch	1
Ring Terminals	Home Depot	Amp Ring Terminals	1
Black Hips Filament	Lulzbot.com	Black HIPS 3mm, 1kg, filament (ESUN)	1
Low in the Dark ABS Filament	Lulzbot.com	Yellow HIPS 3mm, 1kg, filament (ESUN)	1
Glue (SCIGRIP Weld-On 3 Cement)	Tapplastics.com	<a href="http://www.tapplastics.com/product/repair-products/plastic-adhesives/weld-on-3-cement/131">http://www.tapplastics.com/product/repair-products/plastic-adhesives/weld-on-3-cement/131</a>	1
Glue Applicators	Tapplastics.com	<a href="http://www.tapplastics.com/product/repair-products/plastic-adhesives/hypo-type-solvent-cement-applicator/409">http://www.tapplastics.com/product/repair-products/plastic-adhesives/hypo-type-solvent-cement-applicator/409</a>	1
Glazing Putty	Autozone	<a href="#">Bondo Glazing Putty</a>	1