

# USER HANDBOOK

MODEL

AM30A

AM45A

AM30MI

AM45MI

AM60MI

AM80MI

AM90MI

Read the user handbook  
before using the heater.

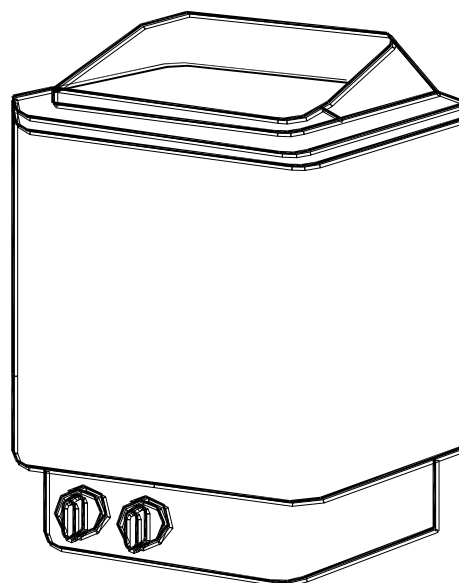

The Heater

- Installation
- Operation

Welcome to select AMXXA and AMXXMI series SAUNA HEATER, with rational design, reliable performance, steady effort and convenient installation. Sauna-bathing equipment is composed of the heater and sauna room. After Sauna-bathing, people feel the flow of the spirits, excrete virus in body, eliminate fatigue, release the muscle and also good for health.

AMXXA and AMXXM sauna heater series is designed for small sauna room, the model as following: AM30A, AM45A, AM30MI, AM45MI, AM60MI, AM80MI, AM90MI, which is equipped with suitable sauna room and control the temperature. (See table 1).

**⚠ Warning:** The heater is forbidden to use the heat of any other purposes.

**ATTENTION:** This appliance is not intended for use by person (including children) with reduced physical, sensory or mental capabilities, or lack of experience and knowledge, unless they have been given supervision or instruction concerning use of the appliance by a person responsible for their safety.

**ATTENTION:** Children should be supervised to ensure that they do not play with the appliance.

Table 1:

HEATER MIODEL	POWER kW	SAUNA ROOM		MIN DISTANCES				CURRENT AND SIZE OF WIRE		ARRANGEMENT  STONES kg
		VOLUME m <sup>3</sup>  MIN MAX	HEIGHT cm	SIDE WALL cm	DISTANCE TO SHELF OVER 500mm ABOVE THE FLOOR	CEILING cm	FLOOR cm	380V — 415V THREE PHASES A N*mm <sup>2</sup>	220V — 240V SINGLE PHASE A N*mm <sup>2</sup>	
AM30A AM30MI	3.0	2	4	190	5	5	110	18	13.6 3*2.5	12
AM45A AM45MI	4.5	3	6	190	8	8	110	18	6.8 5*1.5 20.5 3*6.0	18
AM60MI	6.0	5	9	190	10	15	110	18	9.1 5*1.5 27.3 3*10.0	18
AM80MI	8.0	8	12	190	13	20	110	18	13.6 5*2.5 36.4 3*10.0	20
AM90MI	9.0	9	13	190	13	20	110	18	13.6 5*2.5 40.9 3*10.0	20

## HEATER INSTALLATION

Prior to installing heater, please refer to installation handbook and check it as following points:

- Attach the heater to the wall with a screw, according to chart 1 and table 1 or the size in heater.
- Is the output power and the type of the heater suitable for the SAUNA ROOM? see parameter table 1 (technical data).
- Is the supply voltage suitable for the rated voltage of the heater? An Residual Current Device (RCD) must be installed in the power supply circuit for safety purpose.
- The location of the heater fulfils the minimum requirements concerning the distances given in chart 1 and allow for safety and convenience (see table 2).
- Do not install the heater to the floor or wall recess.
- The required MIN height of SAUNA ROOM is 1900mm (chart 1C).
- Do not use asbestos-cement tile, asbestos-board and this kind of material as wall sheet behind the heater. For this material will cause the temperature of the wall to rise dangerously high.

- Choose the cable wire according to table 1 and the cable wire can bear high temperature 170°C (It is recommended to use rubber cable wire).

Do not install more than one heater in a sauna room unless twin-heater installation (NOTE: Leave 400mm between two heaters when installing two.)

The heater gets very hot when working .To avoid the risk accidental contact with the heater, it is recommended that a heater guard be provided. The guard is made into many kinds of patterns in accordance with the location place, yet some size must be made as the chart ID (see table 2 and chart 4).

The electrical supply must do the installation of the heater to ensure safety and reliability .Improper electrical connection can cause fire or electric shock.. Refer to the chart 8 and 9.

The junction box in SAUNA ROOM must be sealed, splash–proof and have a moisture condensing vent with 7mm diameter , it is maximum height from the floor must not exceed 500mm (see chart 2).

**NOTE:** The above screw must tighten, leave 3 mm between screw head and the wall.

**CHART 1A**

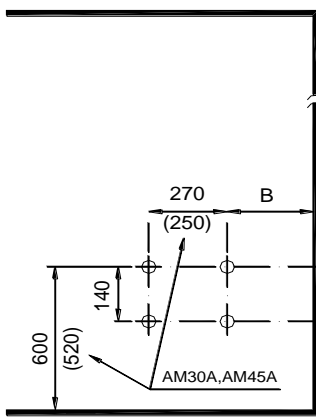

**CHART 1B**

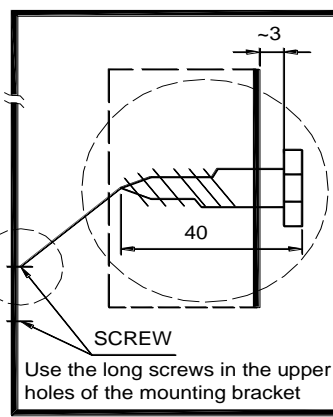

**CHART 1C**

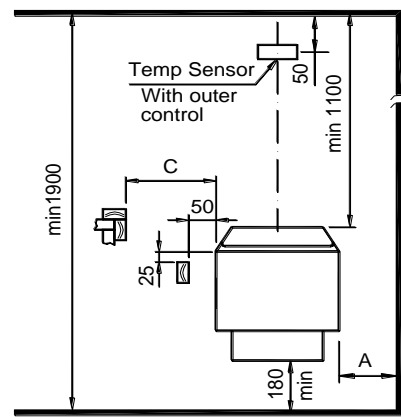

**CHART 1D**

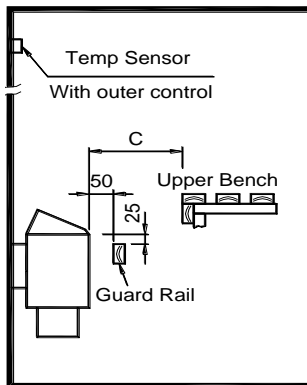

**TABLE 2**

STOVE	A (MIN)	B (MIN)	C (MIN)
AM30A AM30MI	80	110	200
AM45A AM45MI	80	150	200
AM60MI	100	170	230
AM80MI	130	200	250
AM90MI	130	200	250

**CHART 2**

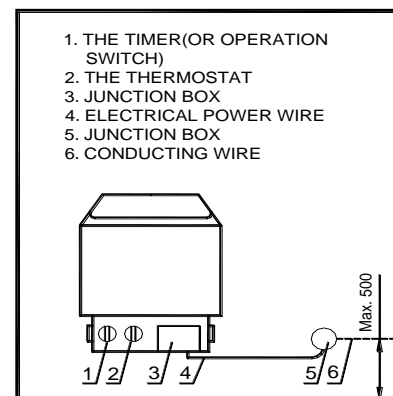

**CHART 3:**

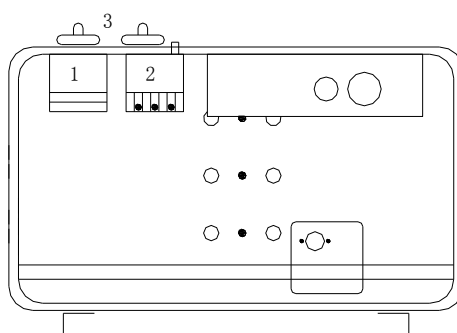

**CHART 4:**

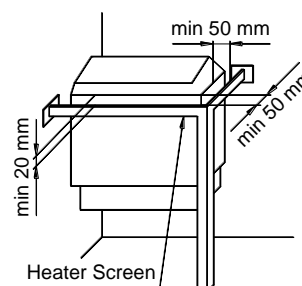

## CONTROL TEMP (INSIDE)

The Thermostat control the temperature by turning operating knob. (Chart 2)

The heater should be equipped with proper size of sauna room. During 30-60 minutes, it reaches the selected temperature and remains (refer to table 1).

## The timer <AMXXA、 AMXXMI sauna series ).<Refer to table 1 unit 1>

The timer is the main power switch in heater

The timer automatically cut off the power if it exceeds the setting time.

## The timer 8+4 hours preset

The timer has 1-8 hours presetting time and 1-4hours operating time. Turn the knob to anywhere between 1-4hours on the operating time scale if starting the heater at once

## CONTROL TEMP (OUTSIDE: CON4)

Outside controls the CON4 use to see “CON4 digital display controller instruction”, circuit diagram see CHART 9.

## ATTENTION: Check sauna room before restart the timer.

## SAUNA STONE <prefer to chart 5>

Do not use the heater without stones, otherwise it may cause a fire , only use the original sauna stone .or the stone for use in heater. Do not use ordinary stone, that may emit harmful substance, easily break and do not possess good heating capacity. Wash the stones to clear the dust before putting them into the heater. Stones of unspecified sizes should not be used. Put the larger stones at the bottom of stove compartment and the smaller ones on the top, do not pile them tightly so that air can flow freely.

**NOTE:** too tightly placed stones decrease working time of the heater element. The stones should plainly cover the heater element. (Refer to chart 5). The diameter of stone is about 3-8 cm..

Rearrange the stones in the heater at least once a year or twice if it is in frequent use (maximum 500 hours). To decide the correct volume of stones in the heater, refer to technical data provided (table 1).

CHART 5: (PILING OF THE SAUNA STONES)

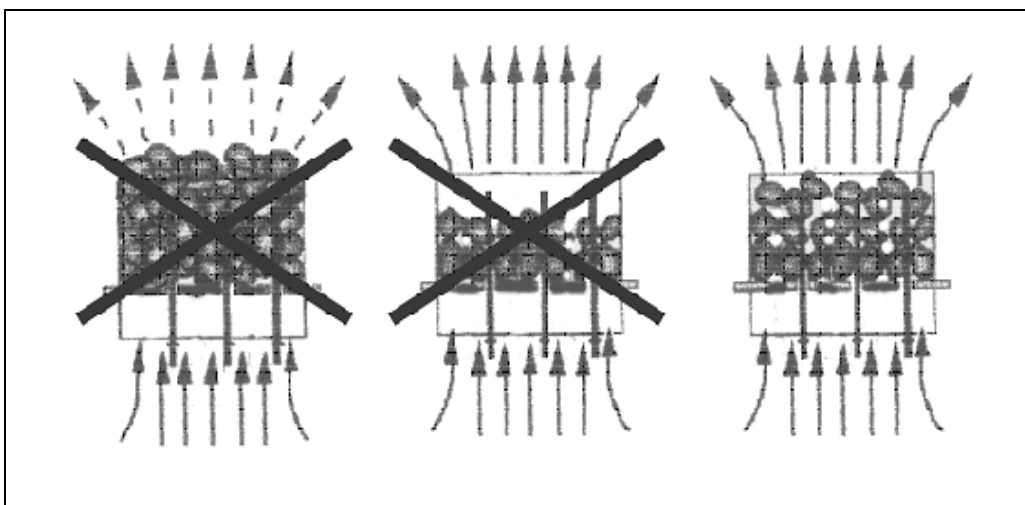

## Air Ventilation of SAUNA ROOM

CHART 6: (LOCATION OF INLET AND OUTLET VENT)

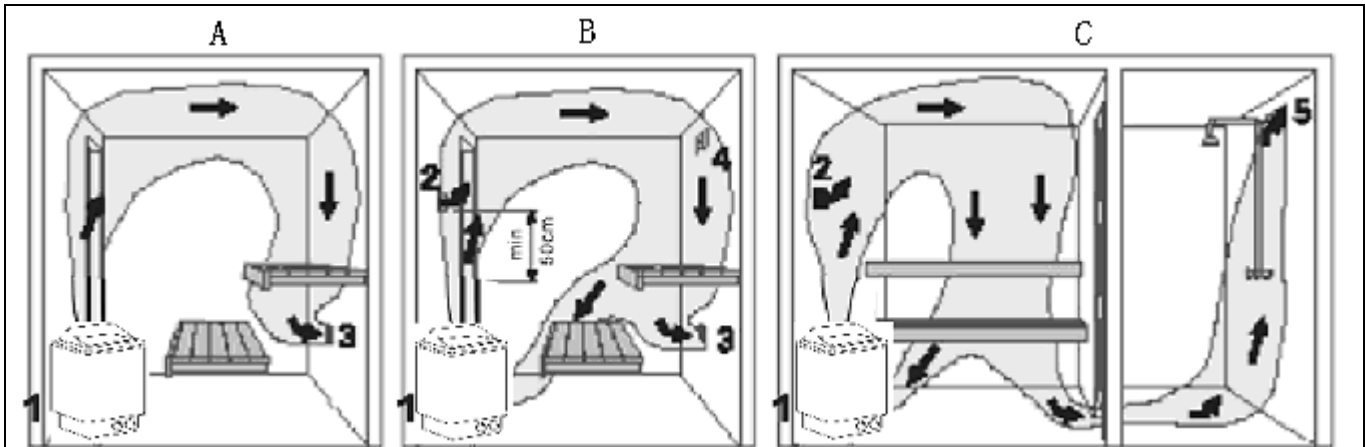

1. Air supply vent.
2. Optional air supply vent if mechanical exhaust ventilation is used, the opening is located 50cm above the heater.
3. Exhaust air vent.
4. Drying vent, which is closed during heating and bathing. Sauna room also dried by leaving the door open after bathing.

If there is only an exhaust vent in washing room, leave a MIN 5cm opening under the sauna room door. (Mechanical ventilation is recommended).

- To ventilate the Sauna room, the way is to draw air around the heater and move the heat to the farthest part of sauna room.
- Considering air ventilation of sauna room, the inlet vent and the outlet vent should be installed.

The inlet vent may be installed on the wall below the heater (chart 6A). When using the mechanical ventilation, inlet vent is placed at least 50cm above the heater (chart 6B) or on the ceiling above the heater (chart 6C). The heavy cold air that is blown into sauna room is mixed with the light hot air from the heater, bringing fresh air for the bathers. The inlet vent should have a diameter of 5-10 cm .

The outlet vent should be placed diagonally opposite to the inlet. It is advised the outlet vent is placed under the platform in a sauna room as far as possible from the inlet vent. It can be installed near the floor, or lead outside through a pipe from the floor going to a vent to the sauna ceiling, or under the door (to the washroom).

In this case, the sill slot must be at least 5cm and it is recommended there is mechanical ventilation in the Wash Room . The size of the outlet should be twice of the inlet.

- Warning:
- 1、 do not power on when connecting electric current and mending .
  - 2、 do not hang clothes to dry in the heater, for this may cause a risk of fire.
  - 3、 do not bake food in heater .
  - 4、 Keep away from the heater when it is hot, the outer surface of the heater may burn your skin.

It is recommended that spruce wood in Northern Europe is used for material of wall and ceiling.

### Insulation.

The door, ceiling and walls of sauna room must be insulated. When one square meter ( $m^2$ ) of un-insulated surface choose the heater input <refer to table 1>.Take following as example (cubic volume increases to approximately  $1.2m^3$ )

Make sure that moisture-proof is appropriate in sauna room. Purpose of this is to prevent spreading moisture to the other rooms or wall structure. Moisture-proof must be placed between panel and heating insulation. Moisture and

thermal proofing should be installed from outside to inside, such as:

- 1、 Recommend that the MIN thickness of the thermal insulation in the walls is 50mm and in the ceiling 100mm.
- 2、 Aluminum foil laminate is affixed over the heating insulation as a vapor barrier.
- 3、 Leave at least 20mm air slot between vapor barrier and inside panel.
- 4、 Leave a slot between wall panel and ceiling to prevent gathering moisture behind the panel.

## Heating of the Heater

Ensure there is nothing near the heater before switching on it. The heater and the stones may emit smells when you use the heater for the first time. Make sure that the sauna room has been efficiently ventilated or open the sauna room door. It will take about an hour to reach suitable temperature in sauna room if the output of heater is proper.( CHART 6) ;

The temperature that bather preferred to is about +60-+90<sup>0</sup>C. Too powerful heater oil heat sauna room too quickly and the temperature of stones may remain insufficient. Consequently, the water thrown on the stones will run through and do not produce sufficient vapor. On the other hand, if the heater is underpowered the heating time will be much longer.

## Malfunctions

If the heater doesn't work, check the following (Note: witch off the heater before checking >.

- |  |                     |                    |                     |
|--|---------------------|--------------------|---------------------|
| 1. front frame                         | 2. stove side frame | 3. heating element | 4. terminal block   |
| 5. heating element holder with o-rings | 6. cable holder     | 7. name plate      | 8. supply wire set. |

**⚠Warning:** Never put cover on the heater; Do not use heater without stone;  
Do not put wood on the heater; Do not use chlorinated water.

**CHART 7: DIMENSION OF SAUNA HEATER**

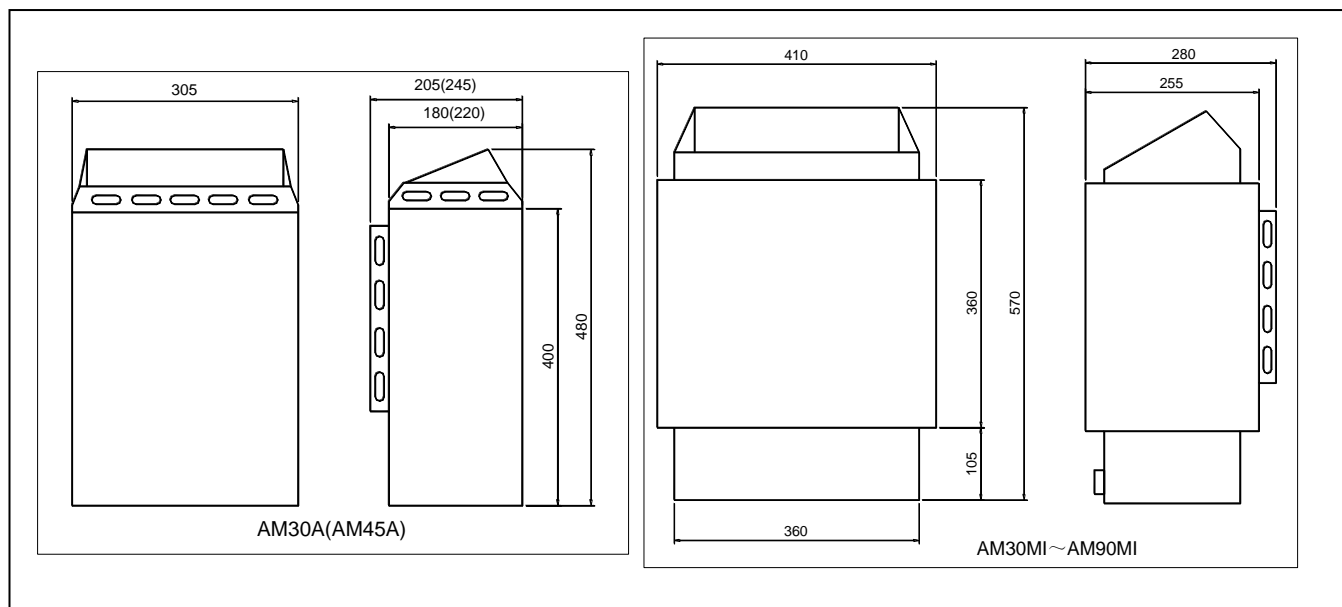

**CHART 8: CIRCUIT DIAGRAM (CONTREL INSIDE)**

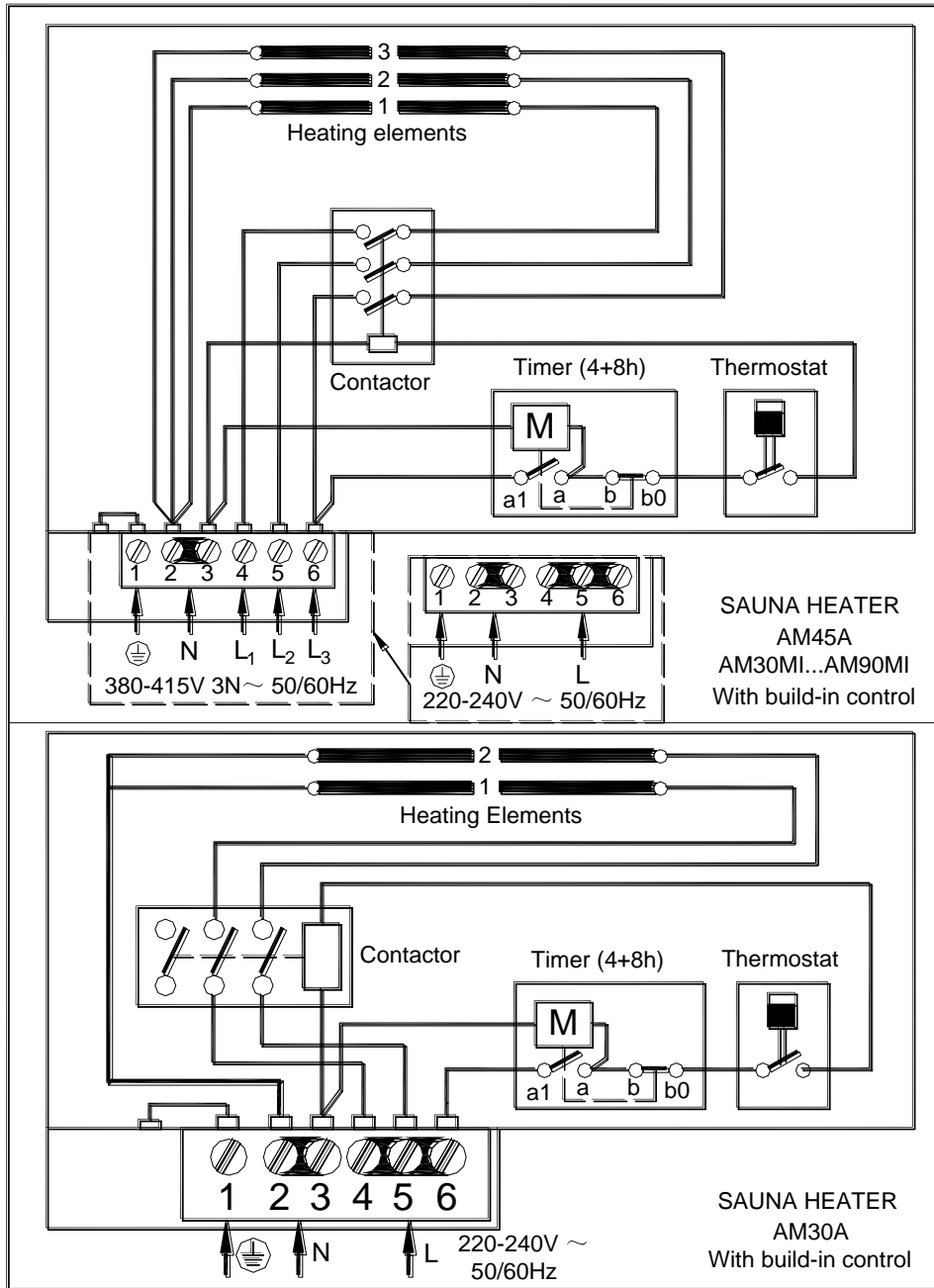

**CHART 9: CIRCUIT DIAGRAM (CONTREL OUTSIDE)**

