



The Multimachine \$150, 12" Swing, Metal Lathe/Mill/Drill

Author: Pat Delany

Tools used in this project

- [\\$10 dial test indicator](#) (1)
- [A hand or electric drill \(we have plans for a \\$5 drill that will work\)](#) (1)
- [Mechanic's hand tools](#) (1)

Parts relevant to this project

- [Scrap, pipe, concrete mix and a very small amount of welding.](#) (1)

The Lucien Yeomans “secret” that was almost lost.

Metalworking lathes are necessary to the production of almost everything but are very expensive. In 1915, special lathes made from concrete were developed to quickly and cheaply produce millions of cannon shells needed for World War I. Lucien Yeomans, the inventor, won the nation's highest engineering award for it but sadly the technique was almost forgotten after the war. We re-discovered it as a way to quickly make inexpensive but accurate machine tools for use in developing countries and in trade schools and shops everywhere.

Credits

Design by Pat Delany, rigmach@yahoo.com

Drawings by Tyler Disney, flowxrg.com

Research by Shannon DeWolfe and David LeVine

Dimensioned drawings and support at:

<http://groups.yahoo.com/group/multimachi...>

Many supporting files are at:

<http://concretelathe.wikispaces.com/Curr...>

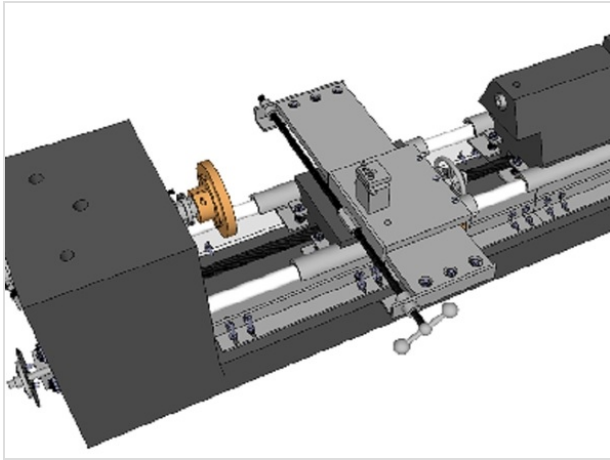

Step 1 — The Multimachine \$150, 12" Swing, Metal Lathe/Mill/Drill

- Bottom-up development for emerging economies. Making machine tools accessible to the developing world with a concrete lathe that can be easily and inexpensively built. The machine tools that fueled the Industrial Revolution in the Western World have become too expensive to be used in the places that most need small industries now. This concrete lathe design can change that. Based on a proven early 20th-century design, it can be made in any size and the same techniques can be used to make many different kinds of machine tools.
- Easily made by a good mechanic using scrap, steel bar and concrete mix. Built using common hand tools, a drill along with a few small welds. Easily converted to drilling and horizontal and end milling.
- Lathe cost is determined by the size of the machine you build and the kinds of good junk you have available.



Step 2

- Many people will not know what this machine is so...A metal lathe or metalworking lathe is a large class of lathes designed for precisely machining relatively hard materials. They were originally designed to machine metals; however, with the advent of plastics and other materials, and with their inherent versatility, they are used in a wide range of applications and a broad range of materials. This is a 100-year-newer, industrial version of the type shown in the step below but this one, the one below and ours all work in exactly the same way.
- METAL LATHES ARE THE ESSENTIAL TOOL IN PRODUCING ALMOST EVERYTHING IN OUR LIVES. Simply put, they are used to make almost everything that is round and they also are used to make the rollers that are used to make almost everything that is flat
- Ours COULD be made in a size that would dwarf this 1500 kg. machine.

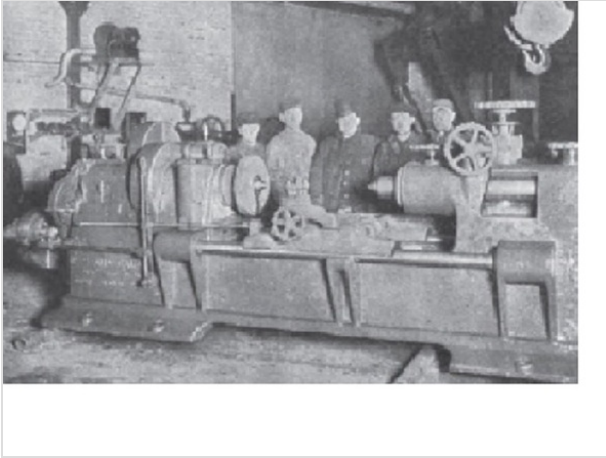

Step 3

- Our idea started with this. What Lucien Yeomans did in 1915 (and we also do) is extremely simple. It is well known that concrete shrinks as it sets up. This is not important when you pour your sidewalk but this shrinkage would force a concrete machine tool out of alignment as the concrete casting dried. Yeomans solved this problem by casting a concrete frame or “bed” with oversize cavities where the parts would normally go and then let the concrete season and shrink. He would then align the metal parts and hold them in place by pouring a non-shrinking, low-temperature metal alloy over them.
- Our lathe design is similar to a typical 250kg 225mm swing (chuck capacity) lathe. Our lathe also has the capacity to mount a common 100mm grinder that can be used to re-surface vehicle clutches and brakes. Ours was specifically designed to be transportable so it could be taken to Maker Faires and yet would also be highly useful in shops. A better choice for many would have ways 300mm between centers and a 400mm swing. Other parts could be scaled up accordingly and would add little to the total cost. A larger lathe would be even easier to build because there would be more room for components.
- Also, on this larger version, the head and tailstocks should be enlarged and the lathe bed (base) should be made at least 150mm thick.

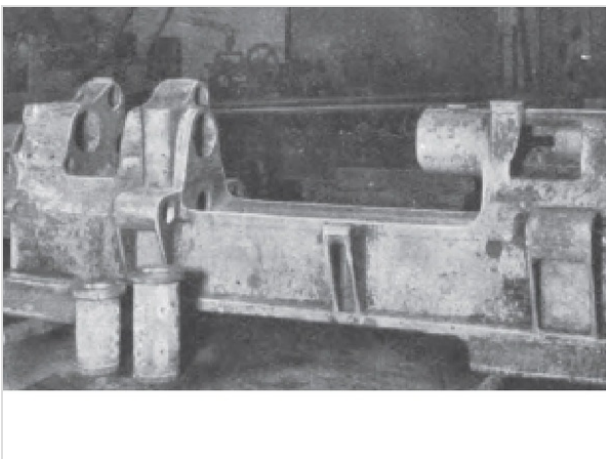

Step 4

- We use the Yeomans technique or a related use of concrete or non-shrinking grout for almost every part of our lathe:
- Fitting the ways to the bed.
- Fitting the “shoes” to the ways and the carriage and then grouting them together.
- Fitting the cross slide to the carriage.
- Fitting the tail stock to the ways.
- Fitting the Morse Taper socket in the tail stock.
- Fitting the spindle cartridge to the headstock.
- Fitting the thread follower spindle cartridge in the head stock.

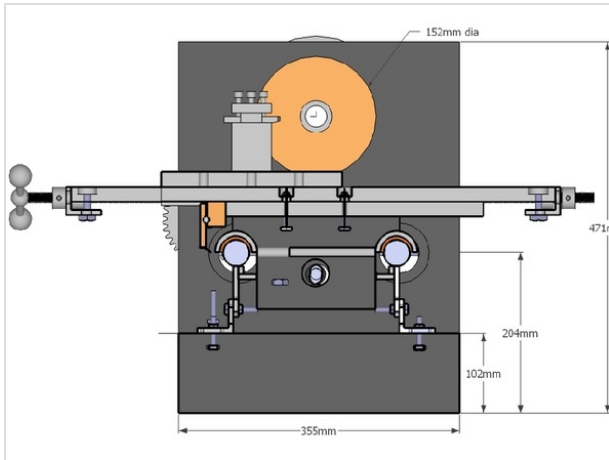

Step 5

- Every part of our lathe can be replaced as parts wear or as improvements are needed.
- The all-thread type lead screws can be replaced by the Acme type.
- Spindle bushings can be replaced by ball or roller bearings.
- The carriage can be replaced with special milling or boring types
- A compound slide can (and should) be added.
- Electronic lead screw or change gear type threading could replace the simple "thread follower" type.
- Steady and follow-rests can be added, as can a turret or powered tailstock.
- The box type cross slide can be replaced by a dovetail type machined on the lathe itself.

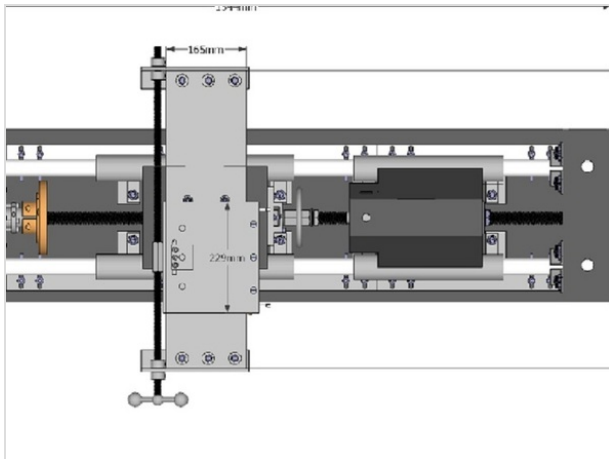

Step 6

- The goal: not the best tool, but one that will work with reasonable accuracy and that can be built by a skilled mechanic using common tools and at the absolute lowest cost.
- This is my effort to get prototypes built. I am 76 and can't walk well anymore so I can't build one to take pictures of. Since I cannot build one, I designed the lathe as a simple combination of long-proven technologies. The machine is based on 5 ideas that have been around for nearly a hundred years or are obvious to someone who works with machines. They are:
 - The Yeomans concrete technique.
 - The cartridge type spindle assembly.
 - Carriage mounting shoes that are connected only by concrete.
 - Supported round ways.
 - Thread-follower threading with wooden clamp jaws that close on a thread that is to be duplicated.

Material

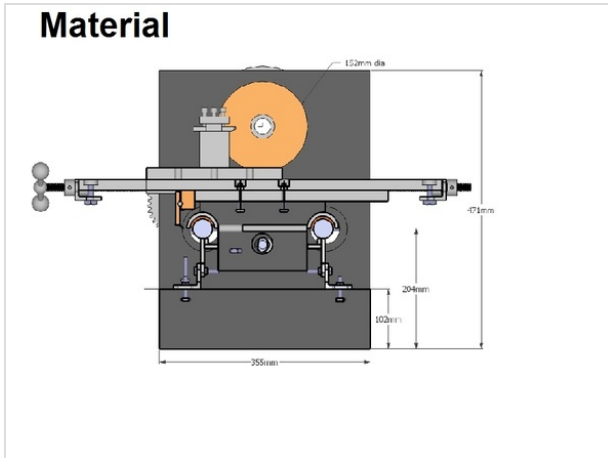

Step 7

- 2 pieces of round, straight steel pipe or bar for the "ways" (the round shiny things that the carriage slides on). THE WAYS ARE THE MOST IMPORTANT PART OF THE LATHE so be very careful as you select them. Good pieces of carefully aligned railroad track could be used on larger lathes.
- Steel bar for the cross slide.
- Scrap pieces of angle iron and pipe for the spindle cartridge, carriage frame and supports for the ways.
- Junked pistons to be melted and cast into adapters, bushings or bearing housings. Casting simple shapes is very easy and gives the machine builder the ability to make thousands of different, useful devices and products.
- Concrete mix, re-bar, fiber additive for concrete and non-shrinking grout.
- These are the kinds of materials needed to build a 300mm swing (maximum length that would fit on the faceplate) screwcutting lathe that would fit on a workbench. A desktop lathe half this size could also be built. Our optimal "shop size" lathe would have ways 300mm (centers) apart, swing of 450 mm and would weigh at least a thousand pounds. A lathe the size of a railroad car could be built using the same basic design.
- The length, diameter and width of the ways are the determining factor in the size of the lathe you build.

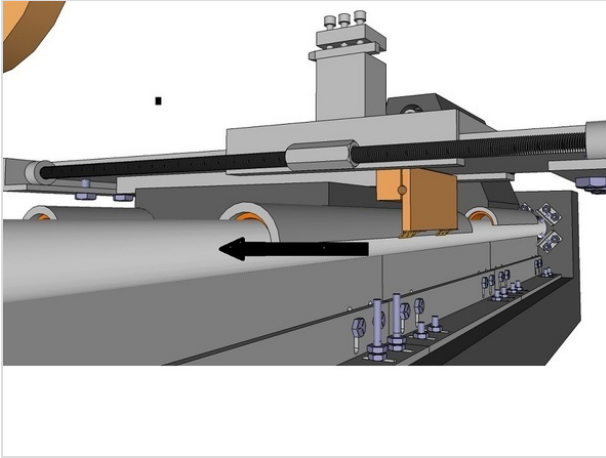

Step 8

- Steel for the ways will probably require a careful search. Needed are (2) 40mm x 1.5 meter (approx) very straight steel rods or pipes (scrap hydraulic cylinder piston rods?) Check them for straightness by putting the round bars or pipe side by side and shining a bright light between them as you first rotate one, then the other.
- A known-good lathe could be used to turn the ways round and straight. If you do have ways turned, be sure to check the ways very carefully afterwards because machining a long piece to an accurate diameter can be difficult.
- Imperfect ways probably could be slowly corrected by the "3 rounds" method that can be found at <http://concretelathe.wikispaces.com/Curr...> The method has not been tested on pipe this large. The 3 rounds method is similar to the centuries old 3 flats method of truing flat surfaces.

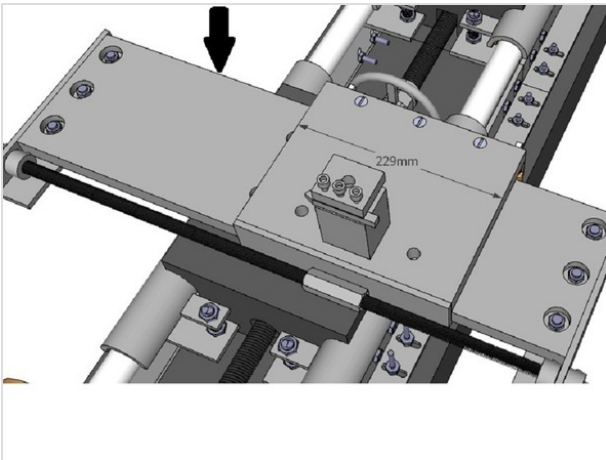

Step 9

- The cross slide can be made using 3 pieces of steel of different widths or built in a more simple version that requires steel of only one width (150mm by 19mm). The 3-piece design is superior because wear is easily adjusted for but it may require cutting a piece of heavy plate to a more narrow width, a job that would be very difficult for many machine builders.
- Finding used steel bars may be difficult. Whatever your source of bar, be certain that the ends have been sawed and not sheared. Shearing distorts the bar ends.
- A more simple way of building the slide will be shown on slide 66.

Scrap pipe, pistons and angle iron

Step 10

- Besides the pipe and bar, a few shorter pieces of steel angle iron and pipe will be needed. The sizes of these shorter pieces depend on the diameter of the ways and the distance between the ways of the machine you are going to build.
- Used pistons are a source of castable metal for bushings and adapters. Piston metal is an easily available alloy has been proven durable running in iron engine cylinders.

Construction and alignment sequence of operations

Step 11

- Building the wooden form and casting the concrete bed comes first. This is not complicated and a good tutorial for this the "Make a concrete counter top" type of book available in home improvement stores.
- Next select, install and align the ways. A carefully held spacer can be used to set the distance between the ways. A piece of float glass plate can be used to put the ways in the same plane. A ball bearing placed on the plate glass can be used to determine if the ways level enough for our use since what is really important is to insure that the ways parallel with the spindle.
- Making the carriage "shoes" (the parts of the carriage that actually slide on the ways) and firmly clamping them over the ways comes next because the wooden form for the concrete carriage is bolted to and then built around them. Firmly clamping the carriage shoes to the ways before pouring the carriage concrete will align the carriage with the ways, a task that will be very difficult otherwise.
- Fit the form for the carriage around the shoes and pour the concrete and let it season.
- If no wood or metal lathe is available, make a temporary lathe out of an auto wheel hub assembly mounted on the headstock and use it to machine spindle bushings, ball or roller bearing adapters. Later, mount the hub and brake assembly on the rear of the headstock and use it as a spindle brake.

Construction and alignment sequence of operations (more)

Step 12

- Make the spindle cartridge assembly from 2 pieces of pipe with simple cast bushings used between them, clamp it in place and align it with a dial indicator mounted on the carriage. Measure from the left, right and center of the carriage. Pour grout through the holes in the top of the headstock to lock the spindle assembly in place.
- Mount a square or a dial test indicator on the spindle and use it to align the cross slide.
- The tailstock is made in the same way as the carriage (though in a different shape!). A Morse Taper drill bit held in the spindle can be used to align the Morse Taper socket in the tailstock.
- Add the smaller parts like the lead screw and handwheel mechanism, pulleys, motor, thread follower and tool post.

Help the project!

Step 13

- If you or people you know are interested in international development, tell them about this. And please let me know if you do.
- If you decide to build one, please take lots of pics for us.

Want to learn about features in historic lathe designs that could be appropriate for use in current developing world conditions?

Step 14

- <http://bit.ly/Ht8vui>
- The era of high speed steel cutting tools but before the time of tool stores, silicon carbide and commercially available coolants.

Lets get started!

Building the concrete form for the lathe bed comes first

Step 15

- Rule #1 is to PAY INFINITE ATTENTION TO DETAIL!. If you don't, errors will compound and you will end up with an expensive boat anchor!
- Build a mock-up first (especially of the carriage). Know the source of every bolt, nut and nail. Don't make a stupid mistake with something that is this big and heavy.
- THINK THROUGH EVERY STEP.

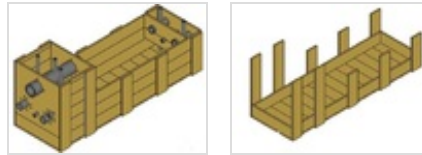
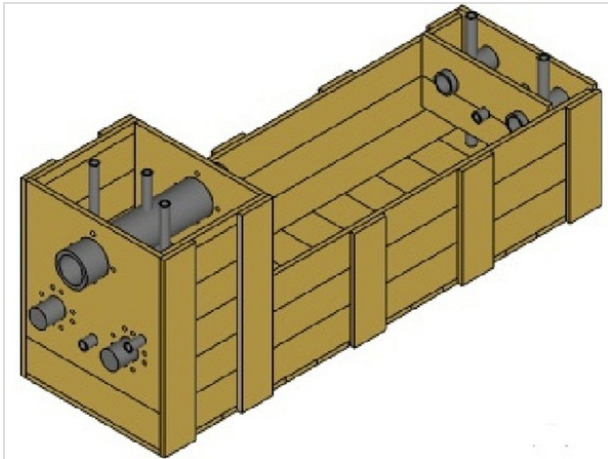

Step 16

- The completed form will look like this.

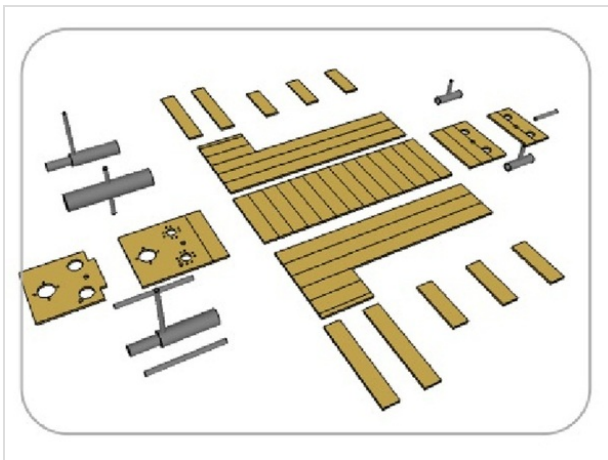

Step 17

- Materials can be as simple as pallet wood and cardboard or plastic tubing.

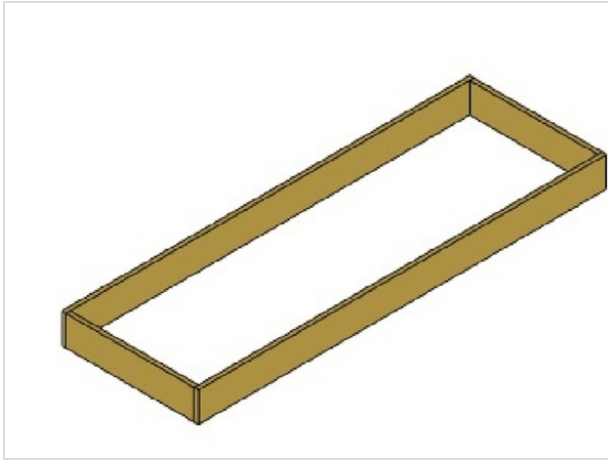

Step 18

- Start with a simple box.

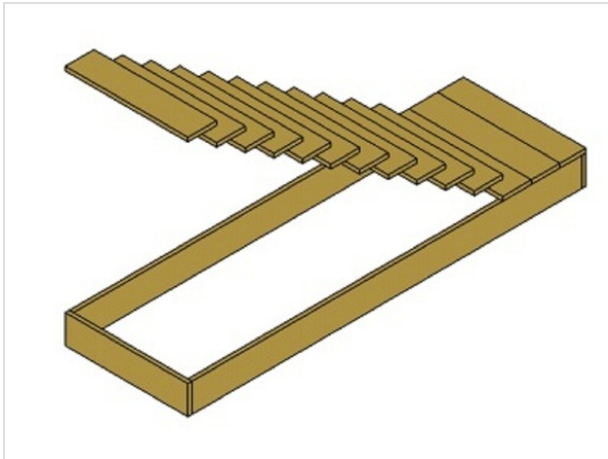

Step 19

- Close up the base!

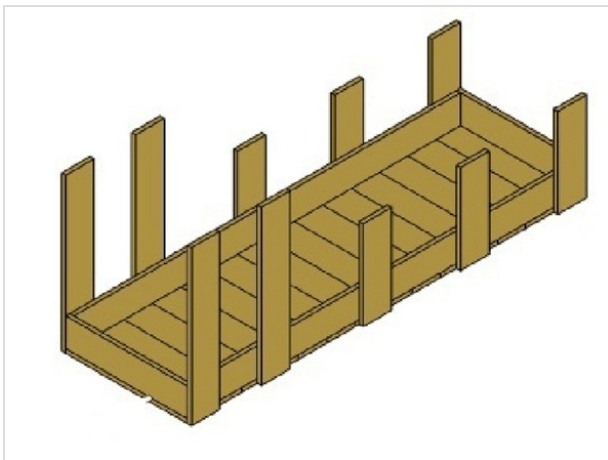

Step 20

- Add the sides.

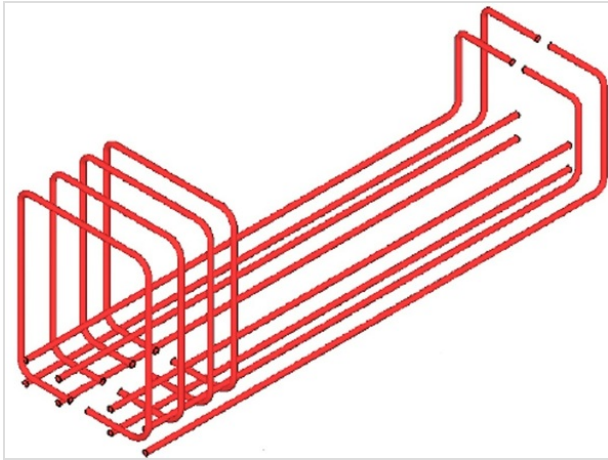

Step 21

- Bend the re-bar.

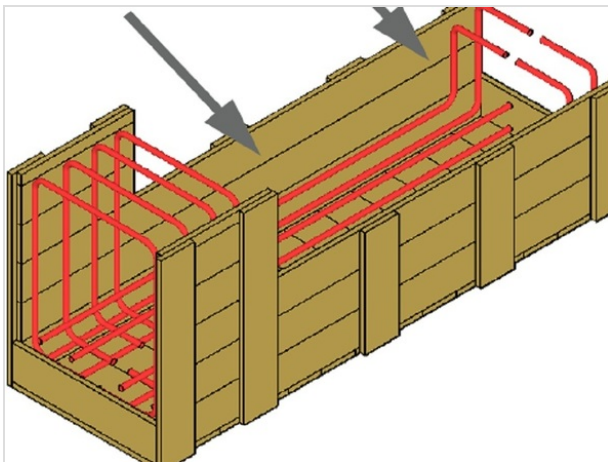

Step 22

- Fit the re-bar into the form.

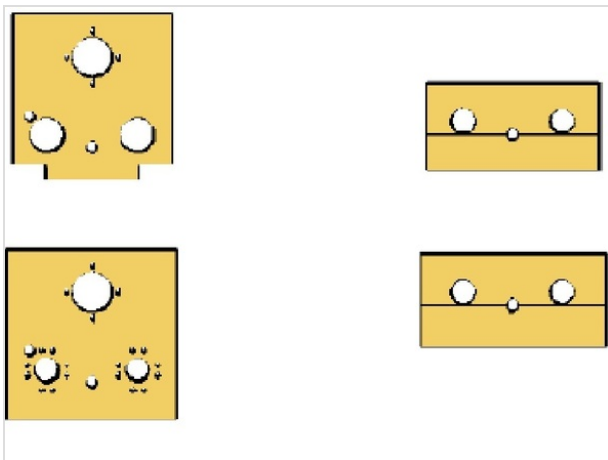

Step 23

- Insert the end pieces into the form.

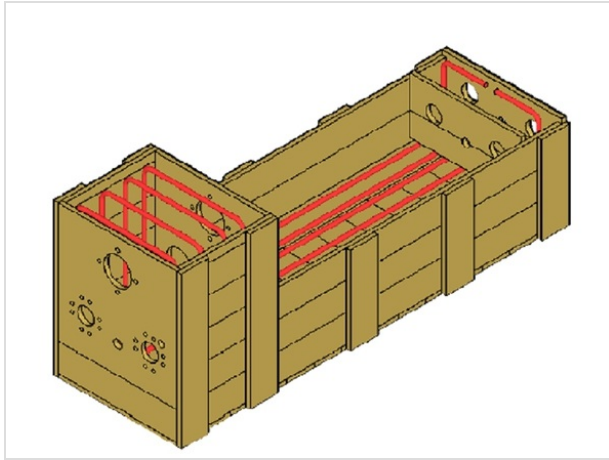

Step 24

- Like this.

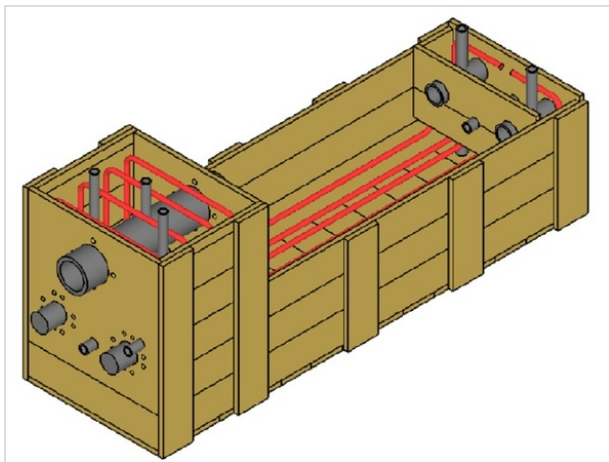

Step 25

- Detail of inserted plastic tubes and bolts. The vertical tubes must be large enough to pour grout through later.

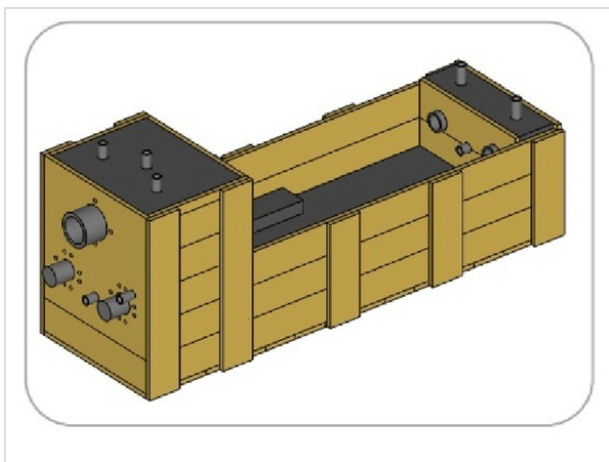

Step 26

- Pour the concrete, embed the way stabilizer bolts and then add the concrete needed here. The way stabilizer base shown here should actually extend the full length of the bed except for a gap that will be used as a coolant drain and to remove chips.

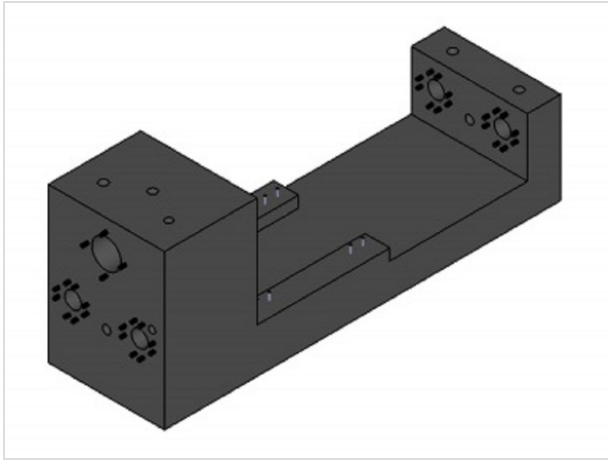

Step 27

- The concrete lathe “bed.”

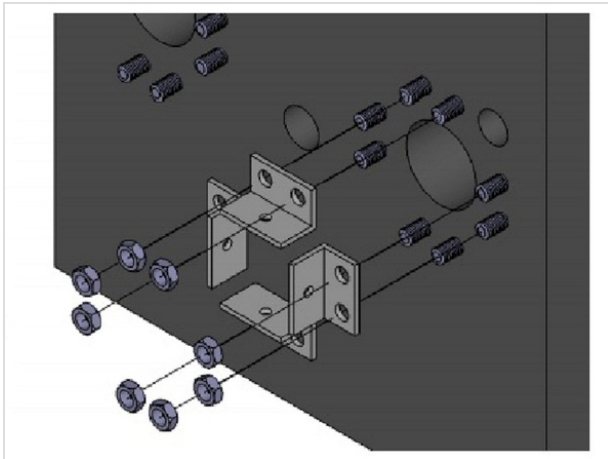

Step 28

- Attach on the way adjusters. They can be cut from scrap angle iron that could be tapped for adjusting bolts. locknuts should be added. If necessary, the adjusters could be replaced with hardwood wedges but accurate way adjustments would be much more difficult.
- After the non-shrinking grout is poured in the way cavities and has a time to set up, the adjusters can be removed and used to make other machines.

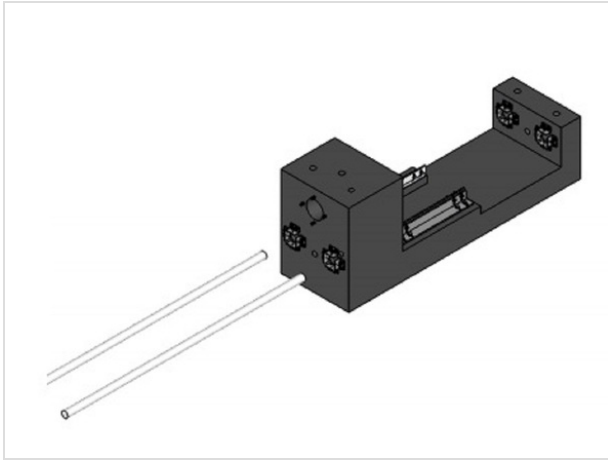

Step 29

- **The Ways:** The ways are the most critical component of an accurate lathe. Selection of the steel and accurate alignment are all-important. Yeomans' lathe used specially ground and hardened round bars that would probably be too expensive for our lathe. If you use pipe it should be made more rigid by filling it with non-shrinking grout. If your budget allows for machining the ways in an existing lathe then certainly do it but don't expect perfect results because many lathes will be too worn to machine the way to the exact size over its entire length.
- Pipe, round bar and hydraulic piston rods come in a great variety: Imperial, metric, straight, bent, chrome plated, rusty, etc. You will need 2 the same size. Any steel must be checked for straightness. A good way to do this is to put the 2 pieces side by side, rotate one while pressed against the other and use a feeler gauge or bright light from behind to check for a gap.

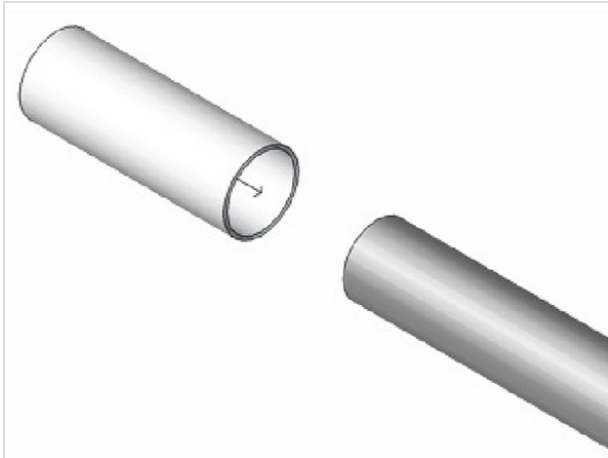

Step 30

- The way ends are very tightly wrapped in greased sheet metal so that the ways can later be rotated to unworn areas if necessary. The sheet metal should be tightly kept in place by wire or hose clamps.

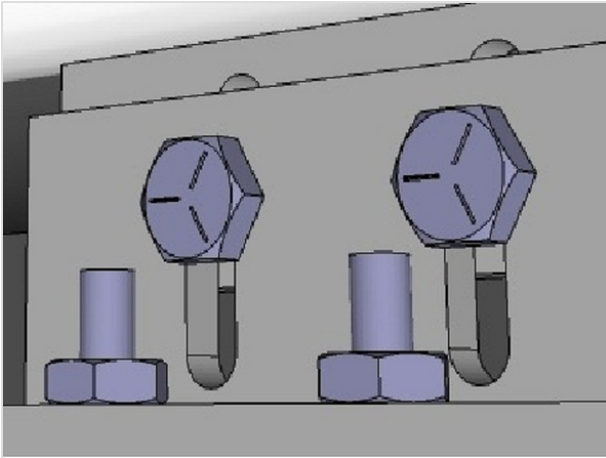

Step 31

- Strong support under the ways makes the use of round ways practical.
- The angle iron and bar stock should be the heaviest that will fit.

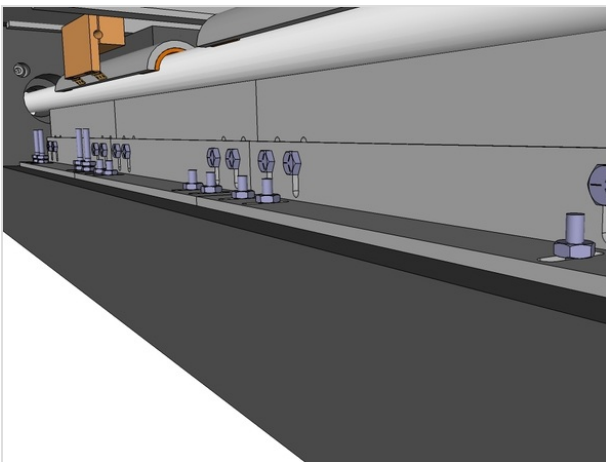

Step 32

- Round ways are used here because they can be more easily and accurately made than other possible choices. However, they must be supported from below to avoid sag and vibration.

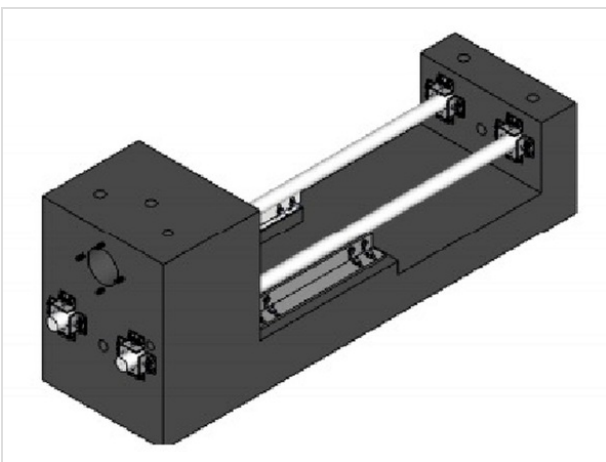

Step 33

- Insert the ways and lightly clamp in place. The supports under the ways are made from angle iron and steel bar. A longer lathe (recommended) should have full length way support. Round lathe ways will both sag and vibrate but a rigid support like this is a simple cure. After the machine is complete, the 16 adjustment devices that are bolted to the concrete could be removed and used to build another lathe.

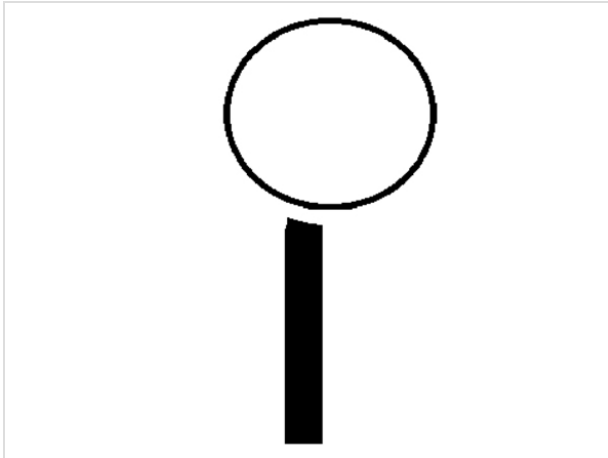

Step 34

- Start with a square-edged way support and once the lathe is running use a flycutter to machine a heavier (1/2", 12mm or larger) bar to fit the radius of the way. The inner edge of the support bar should be at the center of the way. Heavier supports could be especially useful near the chuck where the heaviest cuts will most likely be made.
- If the carriage is heavy enough (75kg ?), there is less danger of the carriage being lifted by knurling operations or a improperly adjusted cutting tool and a carriage clamp may not be even needed.
- A thicker (radius-shaped 25mm?) way support may be needed to handle high horizontal cutting forces in the area close to the chuck. The vertical way support bolts should be laid out with this in mind. Save



Step 35

- Great care must be taken in aligning the ways but the process is actually quite simple. A machinist-type level will make alignment much easier (this is a Grizzly.com \$68 model, a great bargain) but you can do without one if necessary. Use a carpenter's level to set the ways as level as possible. Use a spacer between the ways to accurately set the separation between the ways. This spacer must be kept level, at the center and at exact right angles to the ways. Make a bracket to hold the spacer in a consistent position.
- If possible use a dial indicator mounted on this bracket to measure way separation instead of relying on the "feel" of how the spacer fits between the ways.

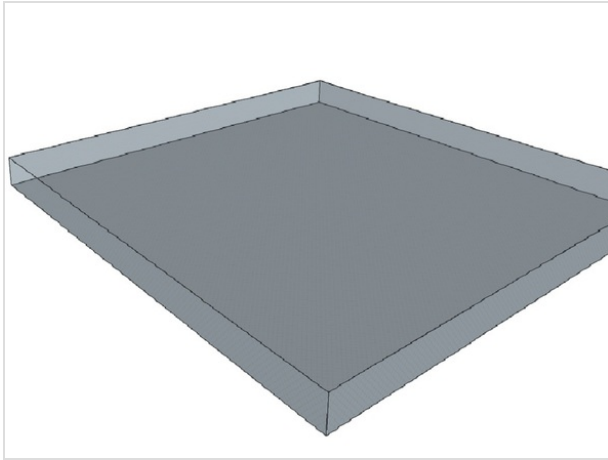

Step 36

- Consider the thickness of a thin piece of paper as an accuracy goal. Use a thick, square piece of plate glass (float glass is best) laid across the ways to check (with a feeler gauge) for even contact on all 4 corners. Rotate the glass and check again (the glass plate may not be perfectly flat). Move the glass plate from one end of the ways to the other to make certain everything is correct. Adjust the way supports for even contact under the ways.
- After the under the way supports are adjusted and tightened, repeat the alignment tests.

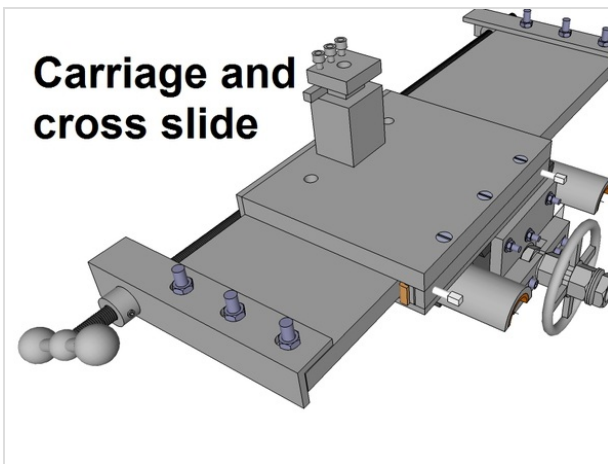

Step 37

- The cross slide can be made in several different ways. The method shown requires steel plate in 3 different widths which may be hard to find in the developing world. An alternate way would be to invert the clamping device. Only 2 pieces of the steel the same width would then be needed but care would have to be taken to keep the exposed sliding parts free of steel cuttings. This 2 plate method is shown in step 66.
- An accurately built carriage is critical to lathe accuracy and will take thought and care in construction. I suggest you study this section extremely carefully so that you will be able to adapt components to the sizes of low cost materials that are available.

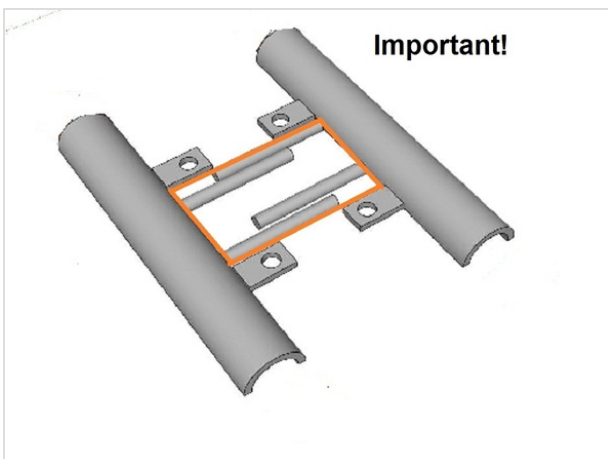

Step 38

- Using a pre-cast, seasoned concrete bed is critical to the project and SO is the steel frame for the carriage. Most machine builders would find it difficult to build a welded or bolted carriage frame that would have the vital even way contact on all 4 corners. We avoid the problem by making the frame in 2 pieces, clamping them to the ways, and then using concrete to fix the 2 sides in place permanently.
- When the carriage is cast, the concrete links the 2 pre-aligned sides together. A simple solution to an extremely difficult problem

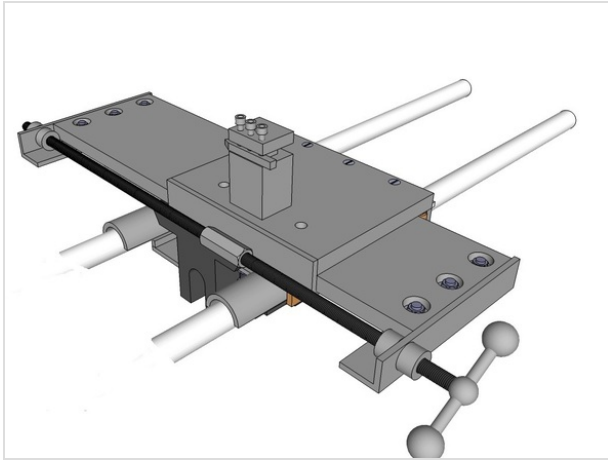

Step 39

- Another view.
- The cross slide lead screw could be either on the leading or trailing edge of the cross slide. If on the leading edge it is closer to the center of cutting forces (good) and more susceptible to chips from machining (bad). If used in the leading edge position, it should have some kind of a plastic cover.

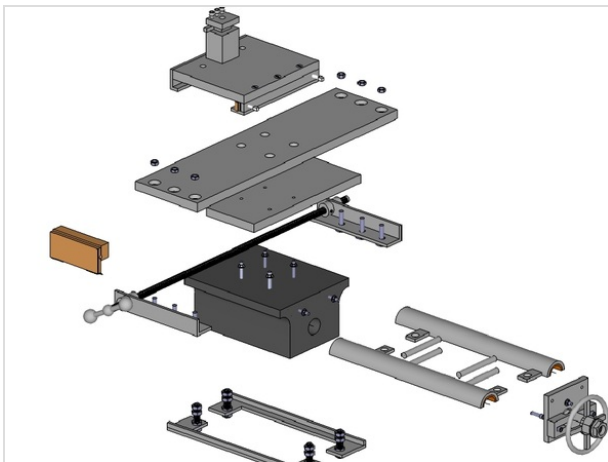

Step 40

- How everything goes together.
- Every fit is critical, however if things turn out poorly you can just make a better carriage and swap it out.
- As long as the ways are accurately made and aligned, everything else is made to be improved upon once the machine runs and has been well tested.

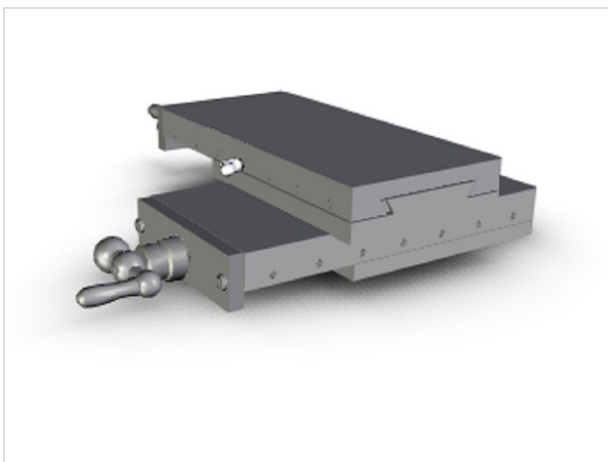

Step 41

- A commercial, dovetail type, compound slide that could be a model for yours.

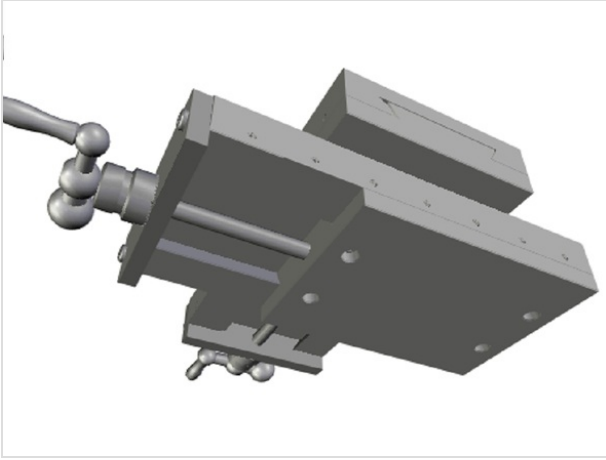

Step 42

- Another view

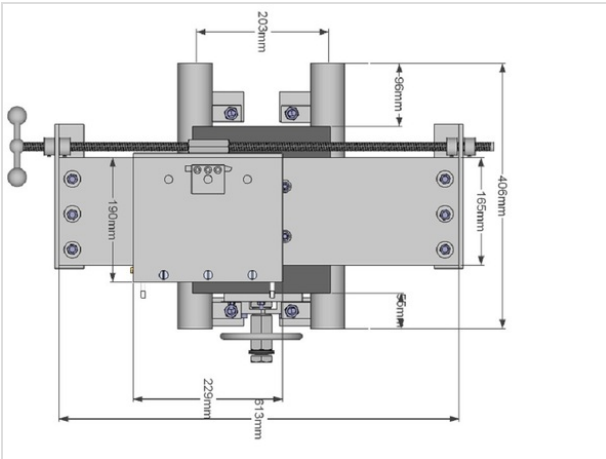

Step 43

- Top view.
- Actual dimensions are better seen in the <http://concretelathe.wikispaces.com/Curr...> Multimachine Concrete Lathe 11.27.11 ver. 1.10.pdf

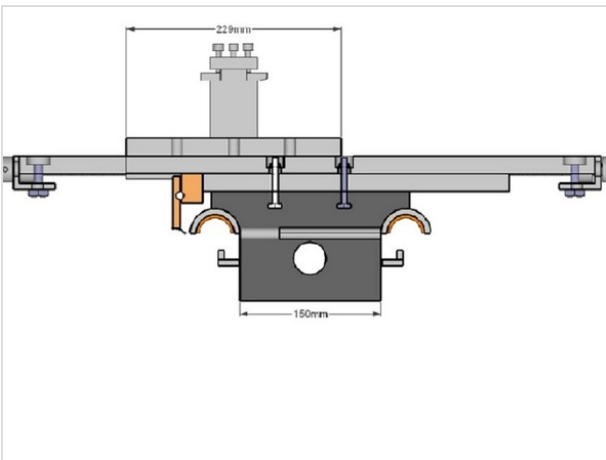

Step 44

- The bolts that hold the top slide down must be very strong (use cylinder head studs?) and should be welded to bars embedded deeper in the concrete than is shown.

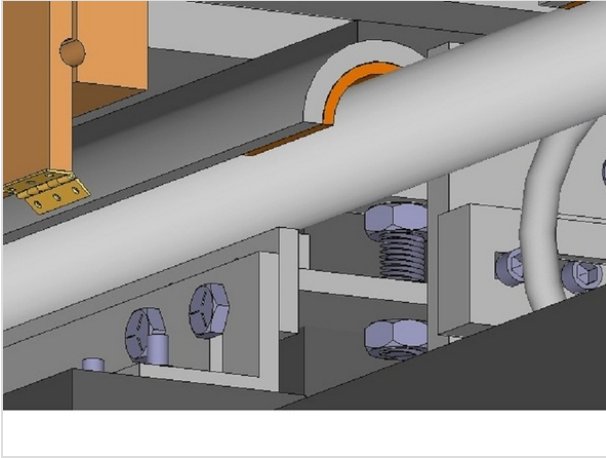

Step 45

- The round ways are supported by a bar that is slightly off center so that there will be room for a carriage clamping device. Since a flat surface can only contact a round surface in a very small area, we take advantage of this fact by using just the edges of two flat surfaces to support the ways and to hold the carriage in place. Normally, cutting forces tend to press the carriage downwards but occasionally the clamps will be very necessary.

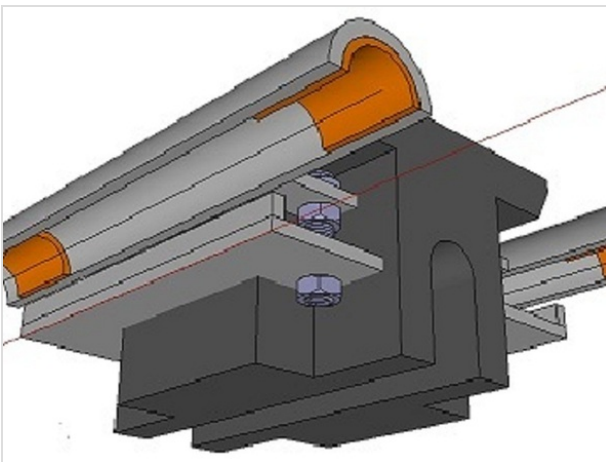

Step 46

- On a carriage for a lathe with shorter ways, space saving techniques must be used. These clamp bolts fit into notches cast into the carriage. A longer carriage will be easier to make because the clamps can be external and the inner parts not so crowded together.

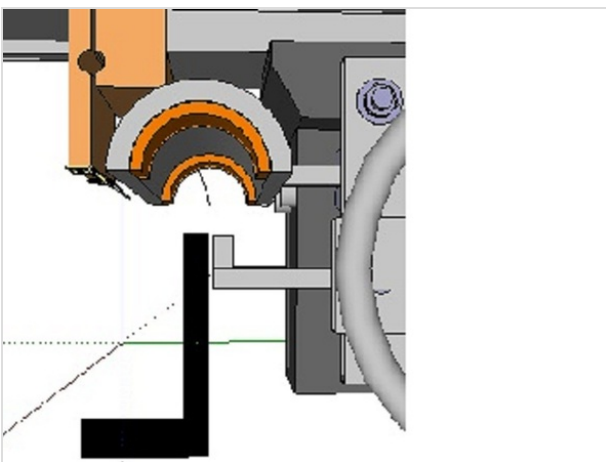

Step 47

- The way support bars and the carriage clamps meet at the center of the ways. The way support bar should actually be shown as a heavy vertical support bolted to a piece of angle iron.
- The carriage is, in effect, pre-aligned. The two shoes are first leveled and then firmly clamped to the ways. They are not mechanically connected until concrete is poured into the form so that it connects the shoes on each side. Any slight distortion from concrete shrinkage can be adjusted for by putting shims between the shoe and the bushings. The bushings should then be lightly epoxied in place.

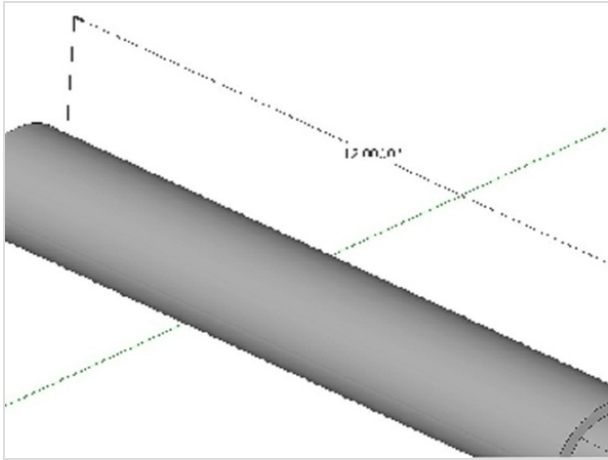

Step 48

- The width of the carriage is determined by the space between the shoes and that is determined by the diameter of the pipe used for the shoes and the distance between the ways. The pipe can be split with a hacksaw or an angle grinder with a cutoff disk. It is very important that length of the shoe should be between 1.5 and 2 times the distance between the way centers.
- The headstock has oversize cavities so that long shoes can slide inside if this proves necessary to keep the optimal carriage length/width ratio. Just extend the shoes past the clamp mounting tabs and adjust the length of the grouted areas in the headstock so that the longer shoes will slide inside the headstock.

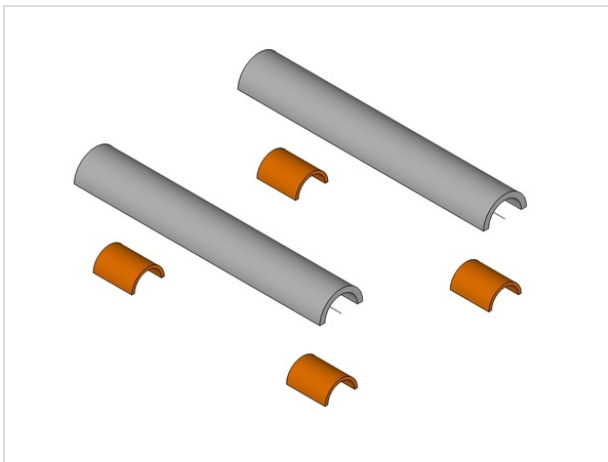

Step 49

- These replaceable bushings are lightly held in place by a small spot of epoxy.

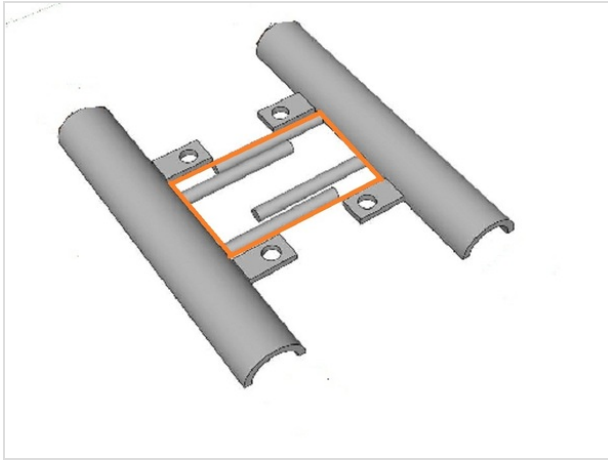

Step 50

- The carriage frame and shoes. The shoes are split pieces of heavy-wall pipe. The inside diameter of the pipe should be about 12mm to 25mm larger than the outside diameter of the way. The bushings will take up this space and could be made from cast iron, bronze or piston metal alloy. The holes in the tabs are used to mount the clamps that contact the bottom of the ways. These holes should be at least 12mm (1/2"). The welded-on cross bars (made from re-bar?) should be large enough to have enough contact area so that they will not flex.
- The placement of the drilled tabs and pieces of re-bar depend on the size of lathe. Adding a foot to the bed length will allow both a longer carriage and a longer tail stock base. A longer carriage and tailstock will let you spread out the tabs and re-bar. The re-bar should be covered by at least an inch of concrete at the side. The concrete should have a fiber additive mixed in. The larger carriage will make construction easier and the carriage heavier and less likely to vibrate and cause tool chatter.

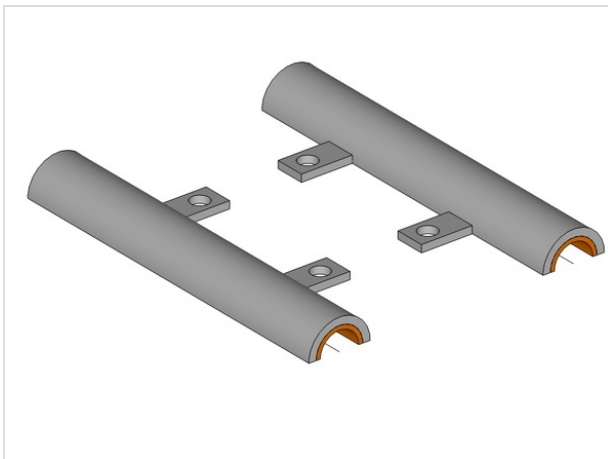

Step 51

- Tab placement again. The safest way to determine tab placement is to actually model the shoes on the ways. The rear tabs will probably be much closer to the end of the shoes than is shown in the drawing. because they will probably have to extend past the handwheel mechanism. (model it!)

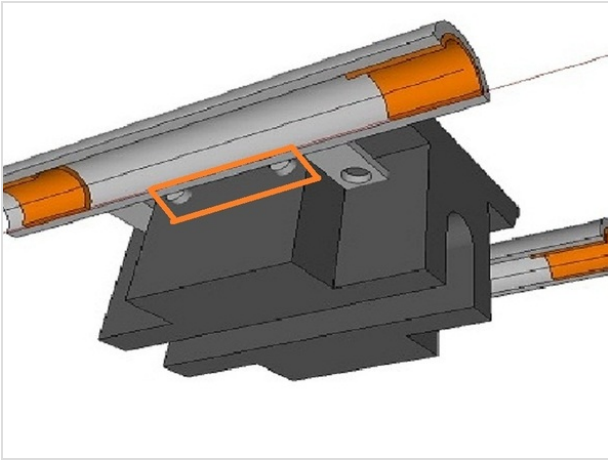

Step 52

- Where the welded re-bar pieces fit into the concrete.
- You can see here that the internal clamps (needed on a short bed lathe) cause a little crowding.

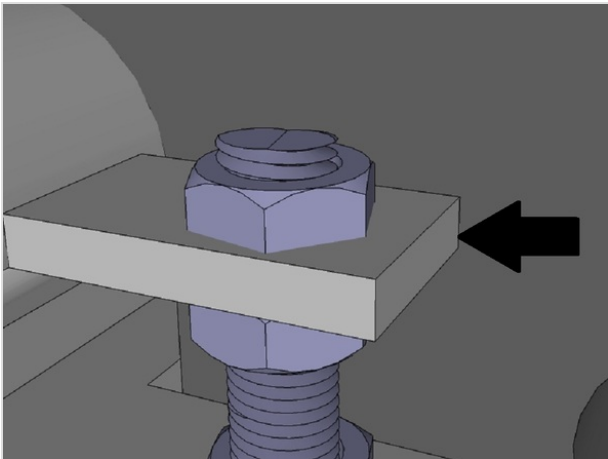

Step 53

- Build the wooden form for the carriage before the way clamps are attached. Use the clamp mounting tabs to support the carriage (and tailstock) form.

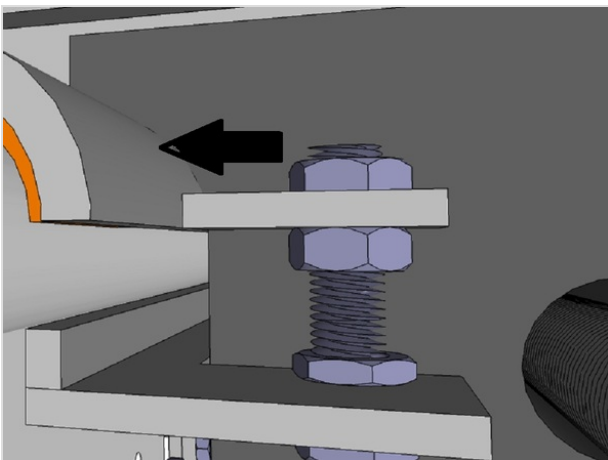

Step 54

- Cast the concrete over the surface of the shoe in this area.
- Start the sides of the form at the bottom edge of the "shoe" that slides on the way.
- The tabs that are welded to the shoes make good attachment points for wooden blocks used to hold the form in place.

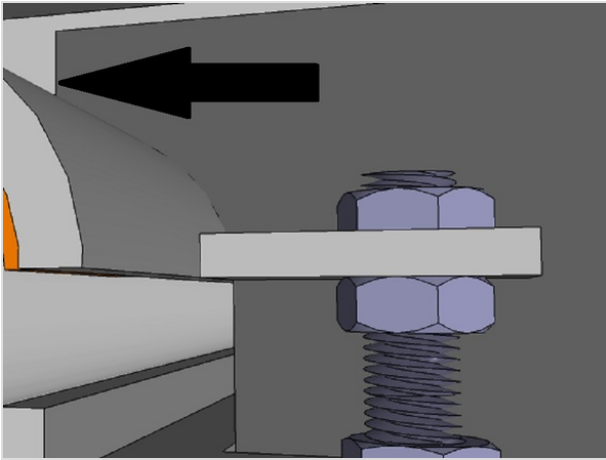

Step 55

- Close in the edge of the form here. Use the widest possible carriage width to support the base of the cross slide.
- Maximum cross slide support area is necessary because the cross slide mounting bolts are closer together than they really should be. Every design is a series of trade-offs, in this case the trade off is caused by having to surround the cross slide bolts with enough concrete so that it will not crack if the cross slide hold down bolts are over tightened.
- A fiber additive should be added to the concrete mix and the concrete mixed for maximum strength.

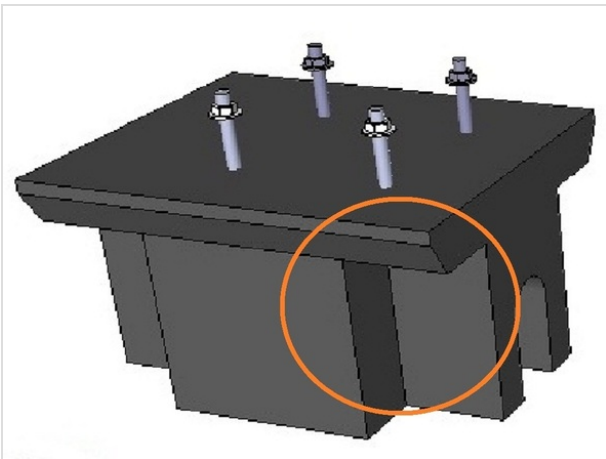

Step 56

- For clarity, the concrete casting is shown without the embedded re-bar pieces that are welded to the shoes. This particular carriage design can be dropped over the lead screw so that it would be easy to replace it with a different or specialized (milling, for example) carriage. Four threaded rods are used to mount the base of the cross slide. These must be of very good quality steel that is firmly anchored in the concrete. Engine head studs would be a good choice here. They should be cut to the proper length and welded to bars that will anchor them in the concrete below the embedded re-bar.
- On a small lathe, great care will have to be taken to fit the steel parts that come from 3 directions! This was the only big problem In scaling the Yeomans lathe down 95%!
- This "cut out" will not be necessary for a long bed lathe that has externally-mounted clamps.
- The inverted "U" shaped cutout is used only if an easily-removed carriage is desired.
- Cored holes should be placed so that the milling attachment and the base of the handwheel mechanism can be connected by pieces of all-thread.

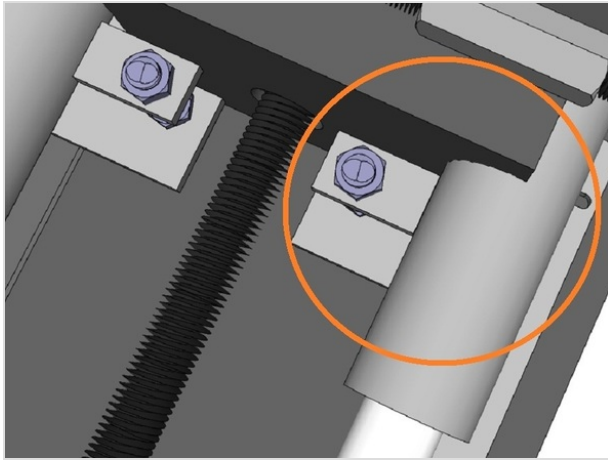

Step 57

- An overhead view of an externally-mounted way clamp.

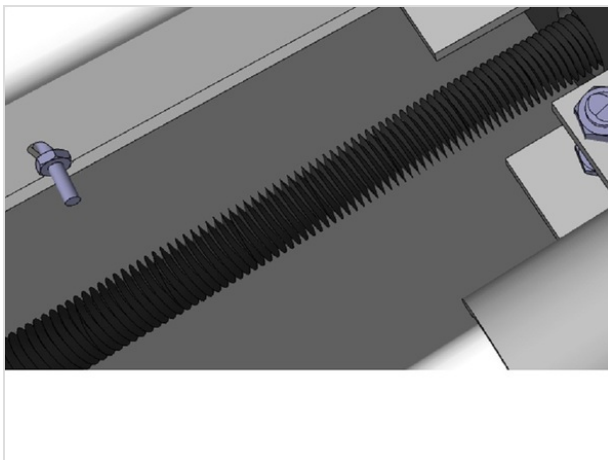

Step 58

- The main lead screw is a piece of threaded rod that does not rotate. The carriage and the tailstock are moved forward by turning nuts that move along the screw. The lead screw is secured by nuts at the foot (end) of the lathe. The carriage and tail stock can be the “drop on” type that is easily removed and replaced. The size of the lead screw could be anything between 18mm and 25mm for this 300mm swing version of the lathe.
- Backlash can be compensated for by adding 2 opposed spring (Belleville) washers and an extra nut. The most common lead screw source is the all-thread rods found in metal shops and hardware stores. Commercial all-thread screws with a black finish seem to be of a higher quality. Cross slide lead screws can also come from auto seat adjusters and auto jacks.
- The quality of the leadscrews are vital to lathe accuracy. Replace the all-thread type with higher quality screws if possible.

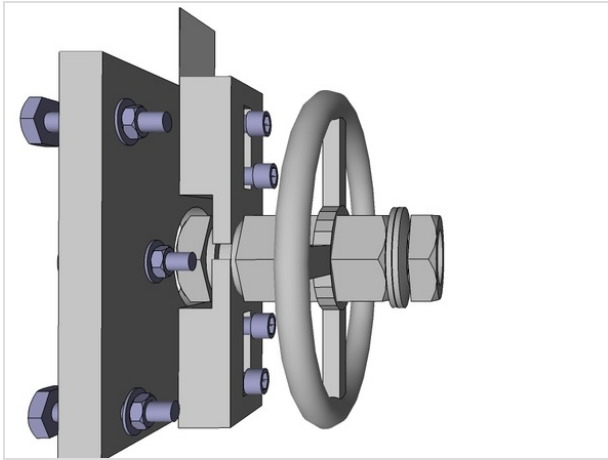

Step 59

- This carriage mechanism is quite simple. Unlike most lathes that have complex "aprons" with many parts, this one just has 5 simple parts that can be built using just a drill, hacksaw and file. The handwheel can be replaced by a bicycle sprocket that later can be linked to another sprocket in an easier-to-reach location. Or, to get the lathe up and running in a hurry (so it can make its own parts), just make the mounting plate, add a nut that can be turned by a wrench to move the carriage forward and heavy springs to pull it back.
- The clamp parts, grooved nut and handwheel adapter could be easily made at this stage. One side of the clamps (above) can be shimmed to reduce backlash in the carriage hand wheel clamp device. The coupling nut could have a larger grooved hub pressed over it to make a larger clamp contact area. If a milling attachment is going to be added, the base can be made longer so that a bolt can go below the leadscrew and connect to it to the milling adapter.

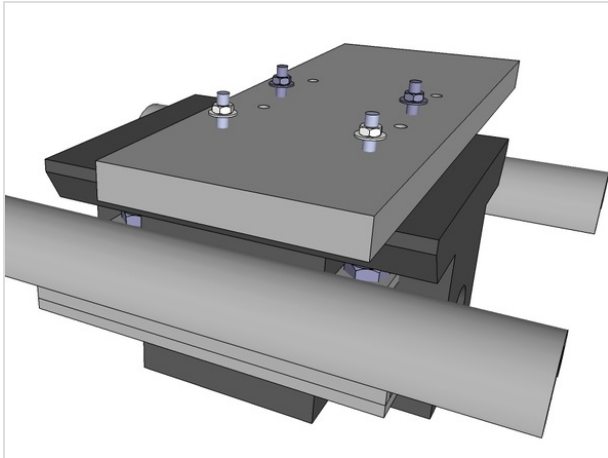

Step 60

- The base plate of a 3-piece cross slide. It is made at least 25mm more narrow than the part above so that there will be clearance for the slide clamps.

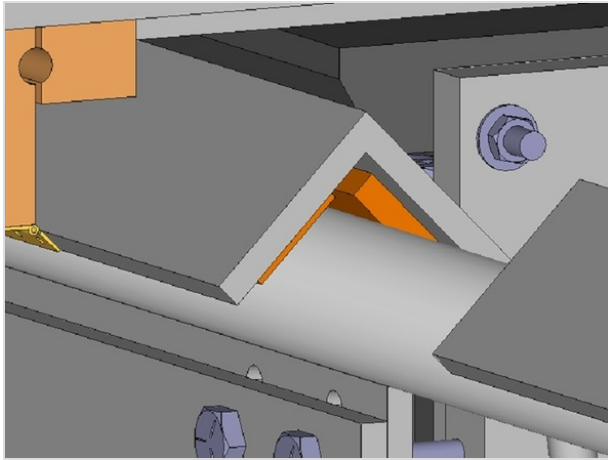

Step 61

- An angle iron alternative to the split pipe shoe. The brass wear strips could be eliminated if necessary.

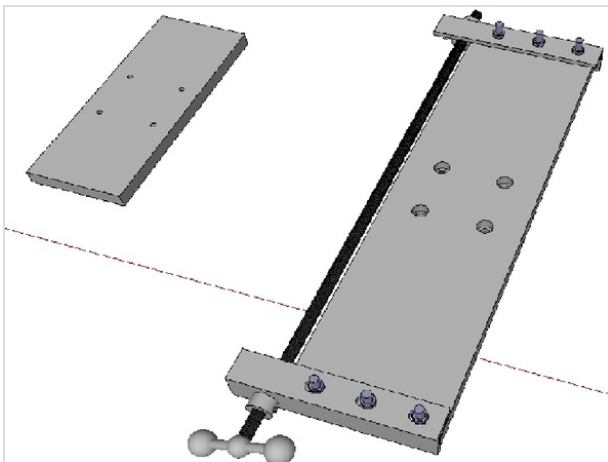

Step 62

- When grinding an optical flat (or other kind of flat), three disks are used. Let's call them "A", "B" and "C". Put A on B with some fine grinding compound. Grind until a frosted finish is seen on both surfaces. Now do the same with B on C. Now repeat with C on A until the surfaces have 100% contact. Repeat this process until it takes little (or no) work to get 100% surface contact in all three combinations. The surfaces will then be very flat. It works on steel as well as on glass.
- How does it work? A on B results in a spherical surface, B on C results in a less spherical (closer to flat) surface, C on A results in an even closer to flat surface after grinding. Each pass results in flatter spheres. If A is concave, B is convex and C is concave. When A and C are ground to each other, they hit the high points first. Now either A or C is concave and the other is convex. Grinding both against B results in the flats being averaged. Eventually they are flat enough. Gravestones and monuments are often VERY flat. They make good layout tables!
- The plate edges are also important since the clamps are screwed to them. Edges of hot-rolled steel plate are not flat and this has to be corrected since clamp parts are screwed to them. Carefully file the edges flat while constantly checking with a square. Keep flipping plates over and end-for-end while checking them side by side until you get them filed to identical widths, with parallel sides and flat edges. Thanks to Dave LeVine for this.



Step 63

- The cross slide lead screw could be a piece of threaded rod but parts from an old gear puller could work well since they usually have a fine thread and the screw is hardened. Later you could make a nut with a similar thread and use it with cupped washers to eliminate most end play.

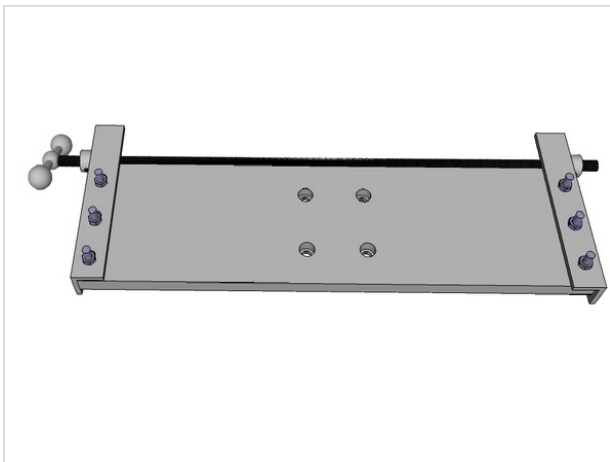

Step 64

- Mounting holes are counter bored 25mm for the nuts that hold it down.

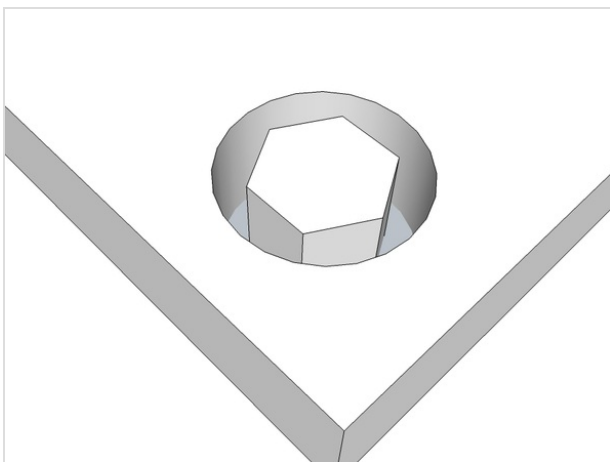

Step 65

- Like this

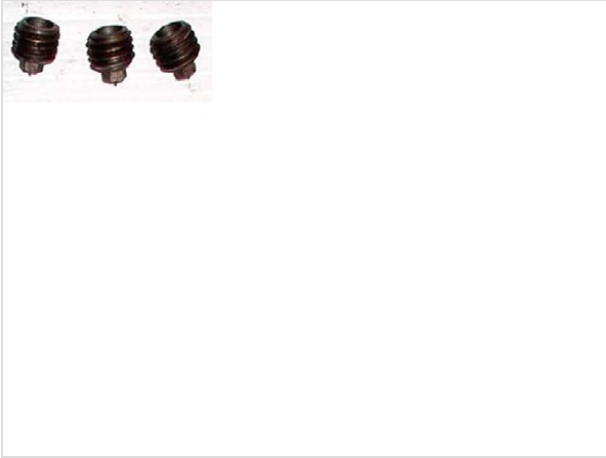

Step 66

- use transfer screws to accurately align the base plate and the 4 studs that are sticking up through the concrete carriage. Screw these transfer screws part way into nuts and screw the nuts onto the ends of the studs. Align the base plate over the transfer screw pointed ends and tap with a hammer. Heavily punch the first hole position, fit and align the plate and mark the remaining holes one by one. Deepen these light marks with a regular center punch and drill with a small pilot drill.
- Make your own transfer screws by epoxying short, sharpened pieces of an old Allen wrench into set screws the same size and thread as the carriage studs.
- If you use an endmill as a counter bore tool, do it after each hole is bored and before the plate is moved, otherwise the hole center will be hard to locate.

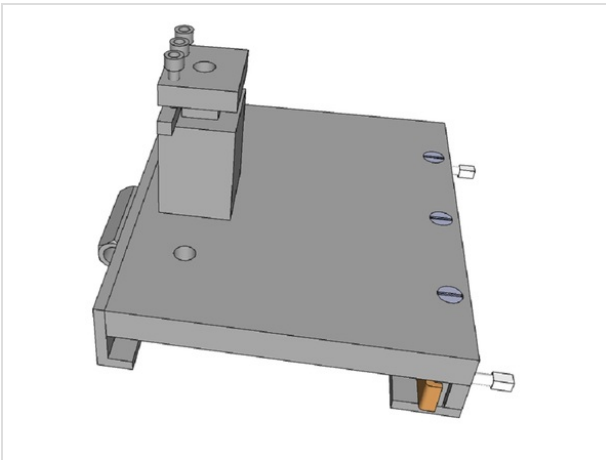

Step 67

- The top slide should be at least 1.5 times as long as it is wide in order for it not to jam when it is advanced under pressure.

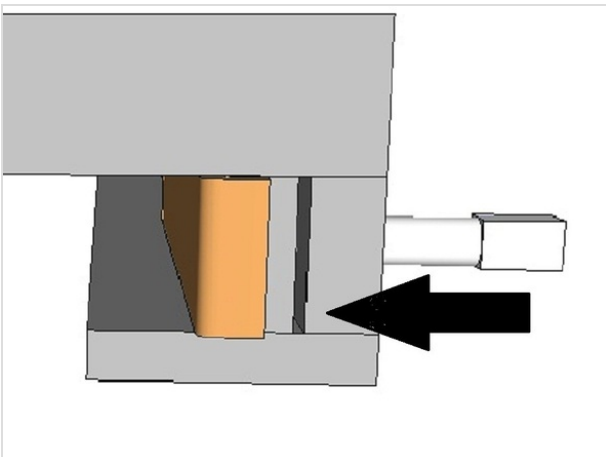

Step 68

- An easily made slide adjuster. The arrow points to a cut in the steel bar. The outer part of the bar is threaded and as the screw is tightened it bends the thinner part of the bar in toward the cross slide. The brass bar is optional.

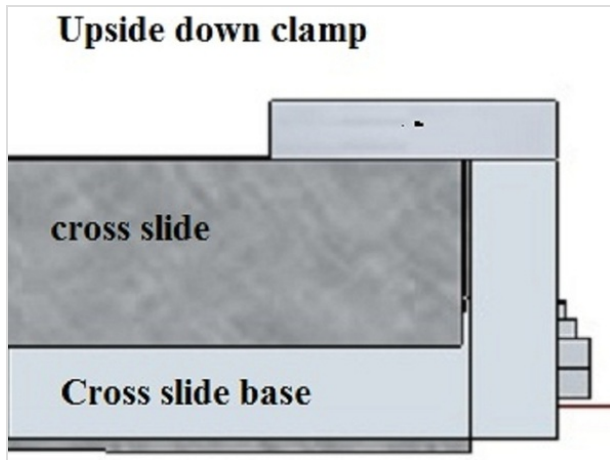

Step 69

- Another way to build machine slides is to invert the clamp. This lets you build the cross slide assembly using just two pieces of steel of the same width. This may be more economical and in some areas might be the only way practical. The disadvantage is that metal particles from machining may get between the clamp and the slide. Leather wipers attached to the edges of the top pieces of the clamp should help with this. Wear could be adjusted for by judicious filing or adding a thin shim.
- A common way to build something like this is to fit it a little too tight and add very thin shims to make things move smoothly. The shims can be removed as the parts wear in and play develops. Another difficulty with inverted clamps is that an additional "compound" slide is made harder to mount because of the more narrow mounting surface. A temporary, light-duty clamp could be made from carefully fitted angle iron.



Step 70

- Cross slide alignment: Use the dial test indicator to measure from the end of the spindle to the top and the edge of the cross slide as it is moved from one end to the other. Be certain that the spindle does not turn as you do this.

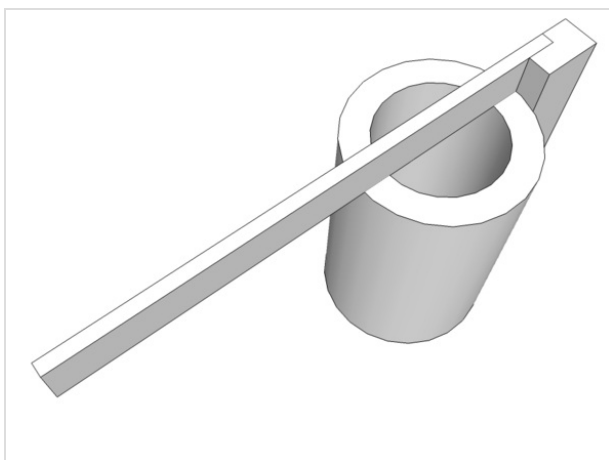

Step 71

- An alternative way of aligning the cross slide is to use a square.

Building a "temporary" lathe

Step 72

- Building any kind of a low cost machine tool takes a lathe of some kind. The aluminum or zinc/aluminum alloy castings could be turned on a good wood lathe but it would be much easier to use your concrete lathe bed and carriage as a "temporary" lathe. Huge savings are possible by casting and turning your own bushings and adapters.

Step 73

- A great many front wheel drive and four wheel drive vehicles (but not all), use a complete spindle assembly which includes wheel bearings, wheel mounting studs, and mounting structures.
- Be aware that some are held together by a center bolt; often the end of a stub axle which is splined. The splines do not matter. The mount can go into the concrete (if the bolts are put in place first), and the faceplate can mount where the brake and wheel did. The old stub axle can complete the drive system.
- While this will not make a hollow spindle (one with a through hole for long workpieces), it is a fine spindle for making the relatively short pieces for a good spindle capsule and for pulleys.
- Using cast aluminum pulley blanks, you can make drive and reduction pulleys for "serpentine" belts (multi-groove type K belts are common in automobiles) which have lower losses and less slippage than more common "V" belts. The pulleys are simple if you can grind a 40-degree tool and the belts can be run "inside out" for initial machining of the final drive parts.
- While building a lathe to make a lathe is not the only way to make a good lathe, it is often beneficial and the less-desirable lathe can still be used to do maintenance when the better lathe is finished. While it lacks a lot of utility (like the ability to turn long workpieces), it is much better than no lathe.
- If the spindle used a disk brake, reversing the disk makes a good faceplate and, if the "hat" is deep enough, a cup chuck.





Step 74

- This is typical of a drum brake setup used on many vehicles. The drum will come off the spindle without too much trouble in many cases. Reverse the drum, add screws (for jaws) and a simple 3- or 4-jaw "cup chuck" can be made. As with the prior spindle design, while it is far from perfect it will work to make parts and train operators.
- Machining pressure plates, brake rotors, etc. does not need a hollow spindle.

The main spindle and cartridge assembly

Step 75

- Many kindle of lathe spindles can be used but for our purposes they should all be enclosed in an outer pipe "cartridge" that could be embedded in concrete after it is aligned.

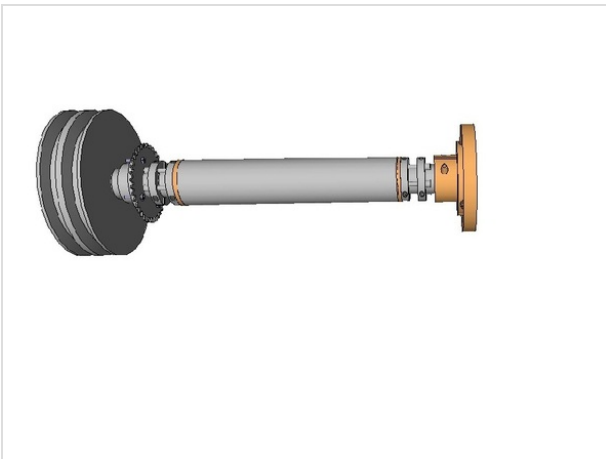

Step 76

- The outer part of the spindle cartridge can be made from a piece of pipe (like the outer part of a hydraulic cylinder), bushings you cast yourself out of piston metal, a thrust device to keep the spindle from moving back and forth and a hollow or solid spindle (like the piston rod of a hydraulic cylinder). The whole assembly is first aligned in the headstock and then (naturally) locked in place by pouring in non-shrinking grout.

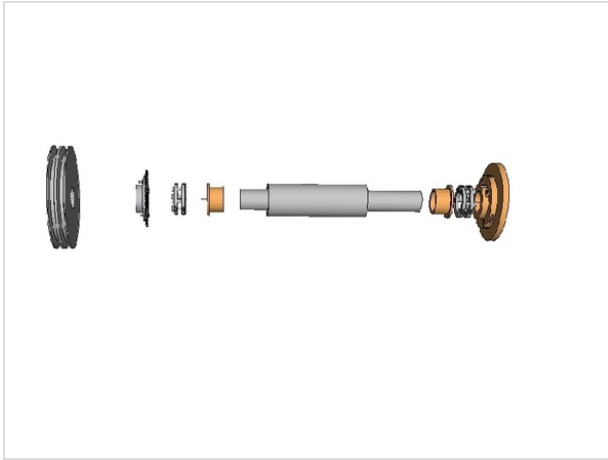

Step 77

- The outer tube protects the spindle and bushings from the concrete. If the outer tube is large enough, the bushings can later be replaced with ball or roller bearing adapters so that a higher speed spindle can replace the initial slower speed bushing type spindle. Adjusters are shown here but the front adjuster could be replaced with a steel washer between the bushing and the chuck backplate, and the rear adjuster replaced with a simple steel collar that could be moved in order to eliminate end play.

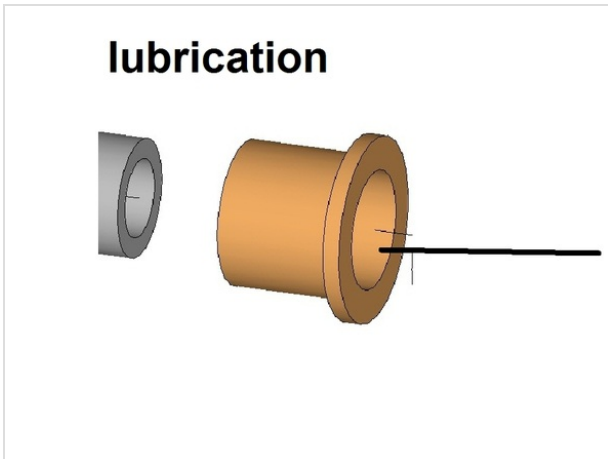

Step 78

- Spindle lubrication: On the main and on the thread follower spindle bushings, cut an "O" ring groove here. Drill and tap the outer body of the cartridges for a 90-degree fitting for an oil line and grout the oil line in place with the spindle.

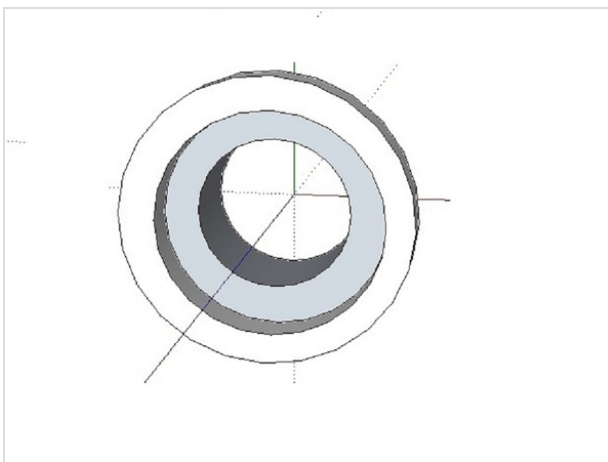

Step 79

- The "universal" shape for for every casting used on the lathe. It can be used for spindle bushings, ball or roller bearing housings, adjusters and a chuck back plate. It is very simple and easily cast.

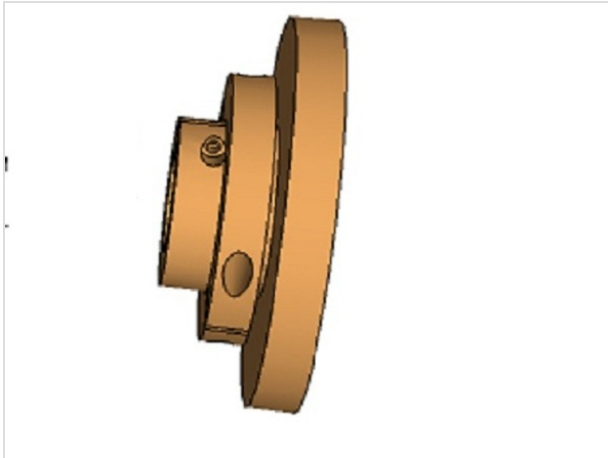

Step 80

- The chuck back plate (mount) is seemingly simple, but if you have to buy one it could cost more than the lathe itself! If you make your own, the two most common choices may be either a piece of cast iron that could be turned down to size or to make one from an aluminum casting. A cast aluminum back plate should have two clamp bolts and nuts (not tapped) on each side and an added steel safety collar. The hub will have to have a large enough diameter so that there will be clearance for the nuts.



Step 81

- Use an old flywheel as a combination faceplate and chuck.
- A slow speed lathe drive could be a shaft with a starter pinion gear and the flywheel ring gear.

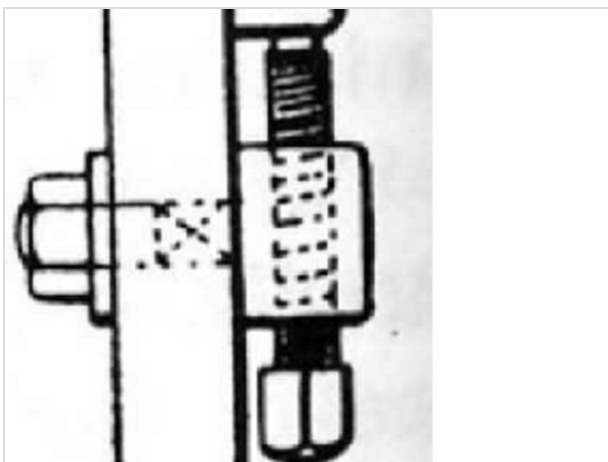

Step 82

- A simple clamp like this can be used on the flywheel/faceplate.

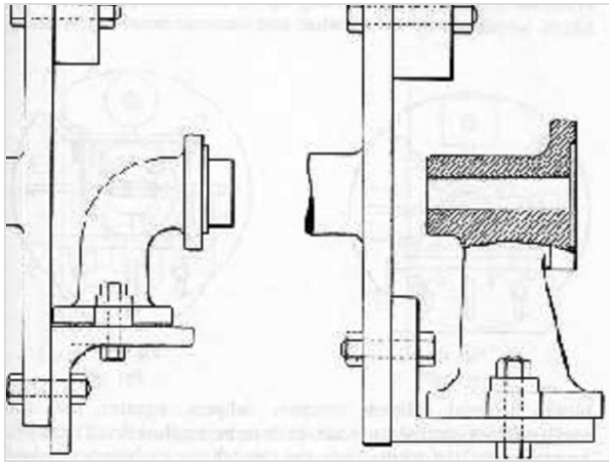

Step 83

- Or this.



Step 84

- A scrapped hydraulic cylinder could provide both the spindle and the outer part of the spindle cartridge.
- The piston rod should be at least 37mm (50 to 100mm is much better) in diameter. It should be 200mm longer than the headstock.

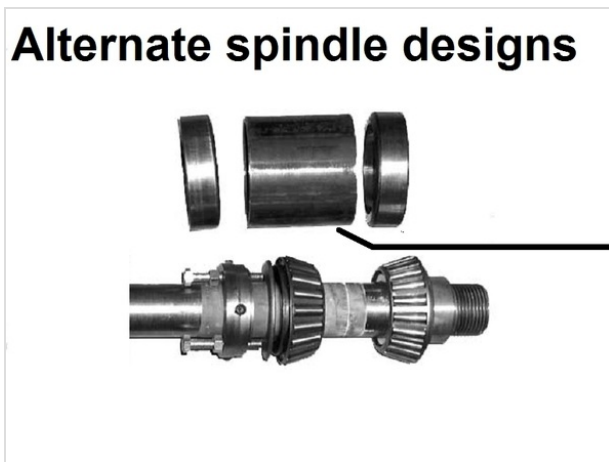

Alternate spindle designs

Step 85

- An original Multimachine spindle design that is heavy duty and very accurate. You may recognize it as the common bicycle front axle type. Spindle size could be based around the sizes of inexpensive automotive tapered roller bearings.
- This type of spindle will require more machine work but, if this spacer was bored on the ends to accept the outer part of the roller bearings and then used as the outer part of the bushing-type spindle cartridge, the simple bushing-type spindle could be made to "bootstrap" this more complex, high-speed spindle at very low cost.
- A bushing type spindle should be replaced by a ball or roller type if the lathe is to get much use as a milling machine since milling speeds are higher than normal (home-made) lathe spindle speeds.

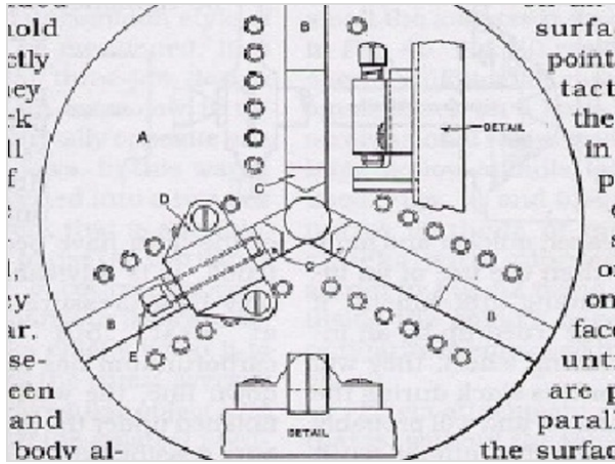

Step 86

- An accurate home-built chuck. Plans are at <http://concretelathe.wikispaces.com/Curr...>

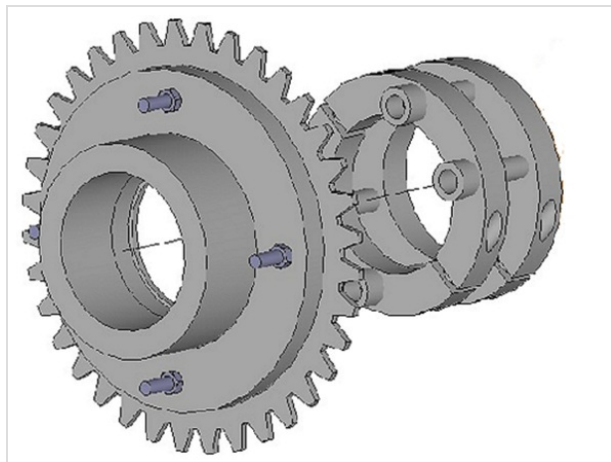

Step 87

- Temporarily, the adjuster could be replaced by the sprocket hub if a steel washer was used between them.



Step 88

- Spindle alignment. Slide the spindle so at least 8" sticks out the front of the headstock, then use a dial test indicator to measure to the spindle to both sides and the center of the carriage as the carriage is moved forward and backward. After the spindle has been accurately aligned, pour in the grout to lock it in place. This makes the spindle parallel to the ways, which is all-important.

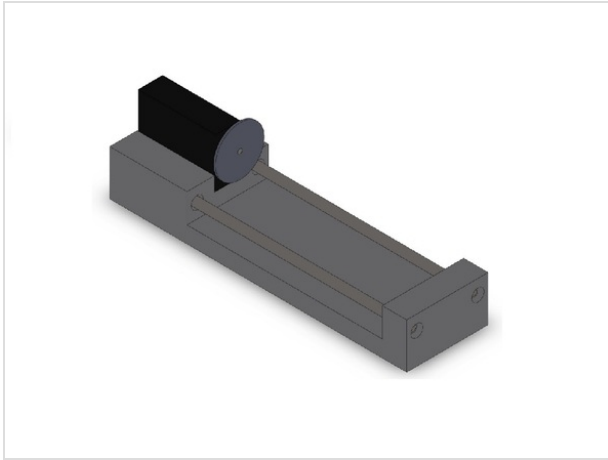

Step 89

- The headstock, spindle and flywheel/faceplate assembly can be as simple as an inverted engine block, crank and flywheel that has had the main bearing inserts carefully drilled and the main bearing caps drilled and tapped for grease fittings. A lathe with a 600mm to 900mm (or larger) swing could be easily made this way. Just remember that the largest Yeomans shell-making lathe weighed 9000 Kg, so scale accordingly!
- An engine block headstock should probably kept at under 200 rpm since the bearing inserts were meant to be used with a pressurized oil system. Grease every few hours at first until you make sure that nothing overheats.

Thread follower threading

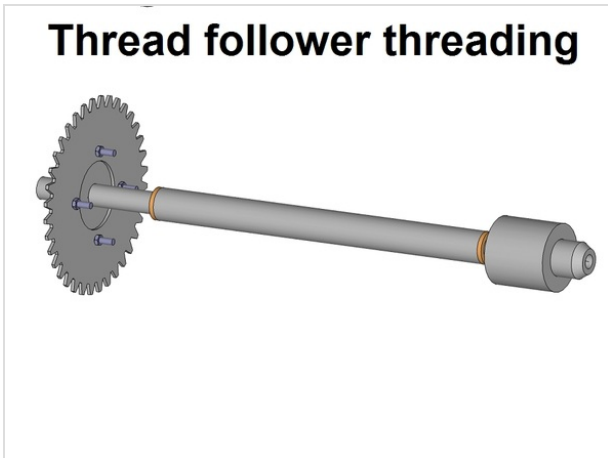

Step 90

- The thread follower chuck rotates at the spindle speed and is driven by bicycle sprockets and chain. An idler should be added so that the chain can be adjusted or removed when not needed. There is a limit to bicycle chain speeds so use a motorcycle chain for speeds much over 70 RPM (which is 3 times the speed you should start threading with anyway).
- To cut a thread, a sample piece of threaded rod is held by the follower chuck and is manually clamped in the wooden or plastic block clamp that is attached to the carriage. This pulls the carriage at the proper speed for cutting a duplicate of the sample thread.
- The follower spindle cartridge is first aligned and then grouted into the headstock.

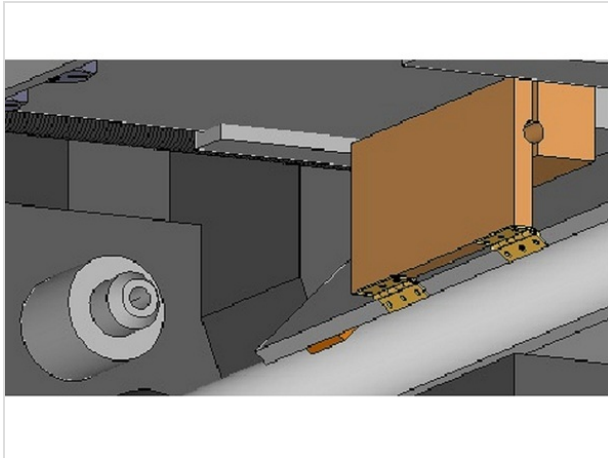

Step 91

- The thread that is cut could be unusually accurate because the wooden block should average out imperfections in the sampled thread. Special note: Threading on a lathe always requires practice even if you use the best equipment. Threading usually takes multiple passes with the threading tool. Our device will require extra practice to learn how to “pick up” the existing thread on subsequent passes but this should not be too difficult because the wooden clamp can be “eased on” instead of suddenly engaged.
- You won't find a device like this described anywhere else but I have built and used one on the original Multimachine. The follower spindle should have an oil line run to it as was described for the main spindle. Half-inch water pipe is about 5/8" ID so this, 2 bushings and a piece of 12mm rod either threaded or epoxied into a discarded drill chuck should work well.
- For a large lathe, the length of the clamp should be increased and larger diameter sample screws made. Compressed air "help" could also be added to a large lathe. An air cylinder could be used to close the clamp on the thread and carefully regulated air pressure supplied to an air cylinder used to add a little push to the other side of the carriage. This would help overcome inertia.

Tailstock

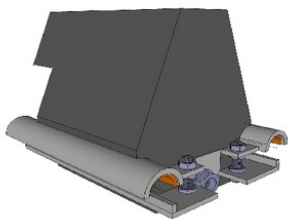

Step 92

- The tailstock has a frame that is exactly like the carriage. Except for the difference in shape, construction is similar.

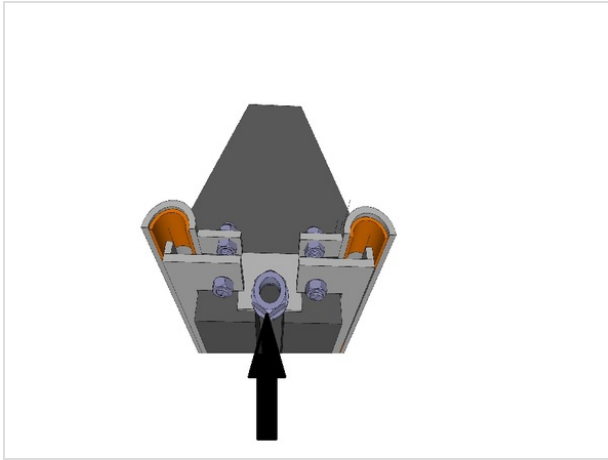

Step 93

- A long nut or handwheel should be added here.

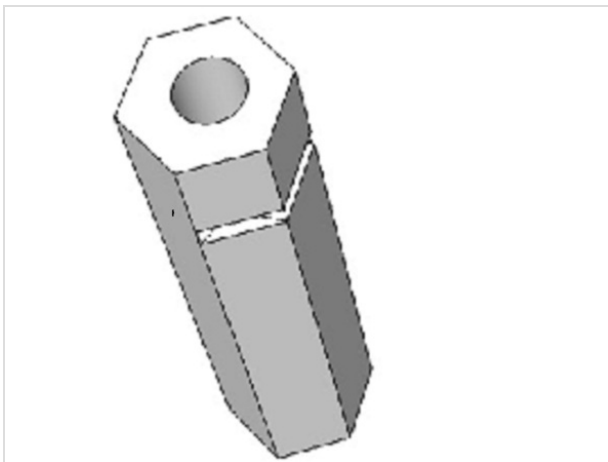

Step 94

- An all-thread coupling nut can be cut in this way and then be pressed slightly closed in order to reduce backlash to a minimum.

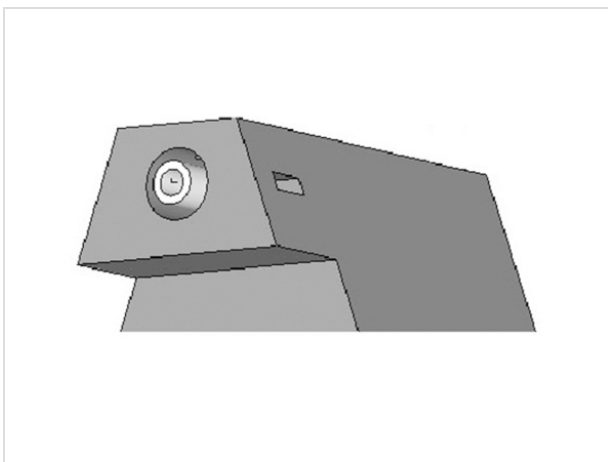

Step 95

- If you use a Morse Taper socket, a slot should be cast into the tailstock concrete so that a wedge can be used to knock loose a Morse Taper tool.
- Naturally, the slots should line up!
- Something should be welded to the back of the MT socket or grooves cut into it so it will not turn or pull loose from the grout.





Step 96

- Align the socket before grouting by using a Morse Taper drill accurately held in the headstock chuck.

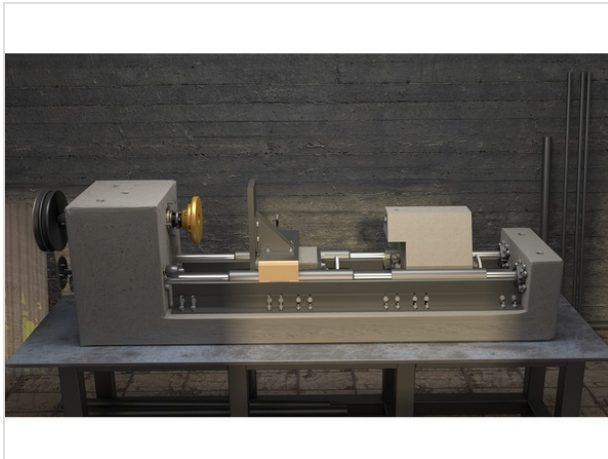

Step 97

- Adapter for milling cross slide

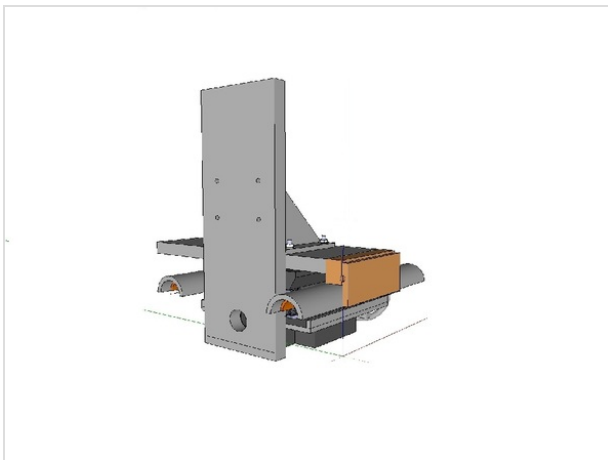

Step 98

- Another view.

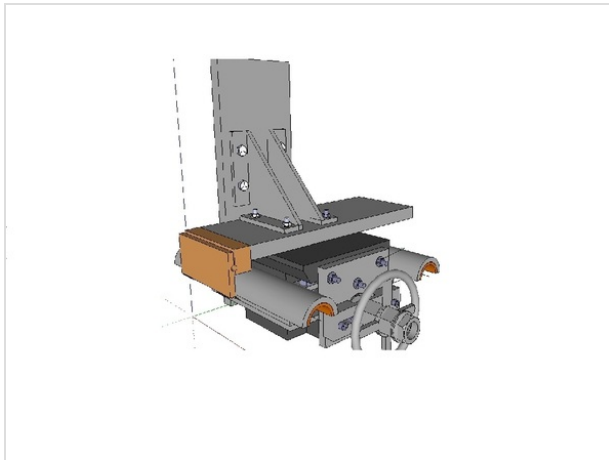

Step 99

- Rear view that shows attachment points.

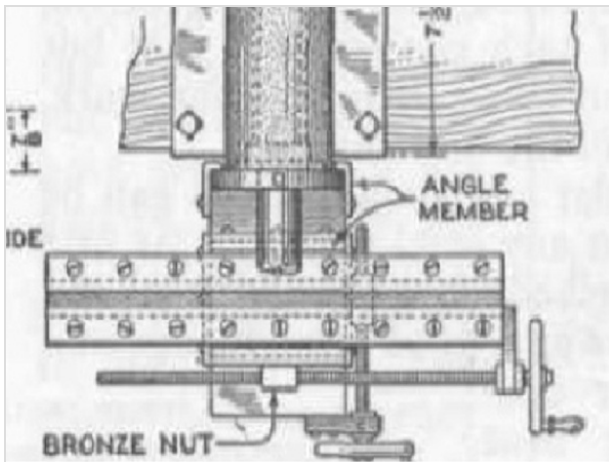

Step 100

- A J.V. Romig milling cross slide design. We mount it vertically instead of horizontally .
- Original plans for this design are bench-mill.pdf at: <http://concretelathe.wikispaces.com/Curr...>

**But wait,
there's more!**

Step 101

- Dimensioned plans;
- Chucks and clamping devices;
- Cutting tools and fluids;
- And more are at: <http://groups.yahoo.com/group/multimachi...>

This document was last generated on Apr 12, 2012.