

TITLE:
Free Spinning Roller

DWG. NO.
RollerPLASTICSECTION

REV: 1

SHEET 1 OF 1

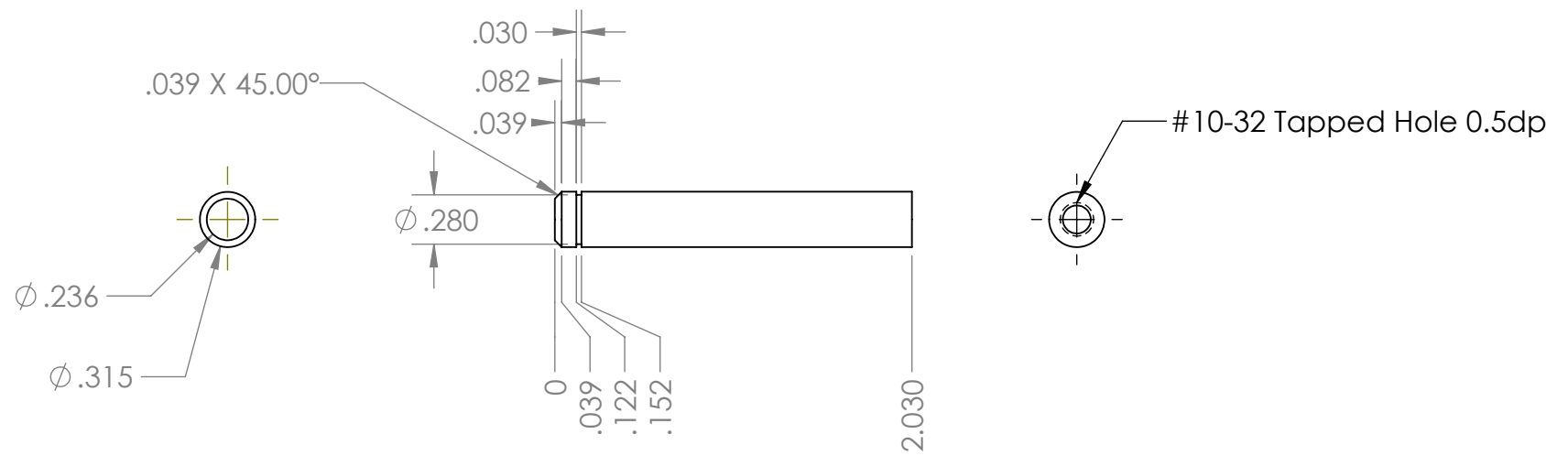

TITLE:
Roller Pin

DWG. NO.
RollerPin

REV: 1

SHEET 1 OF 1

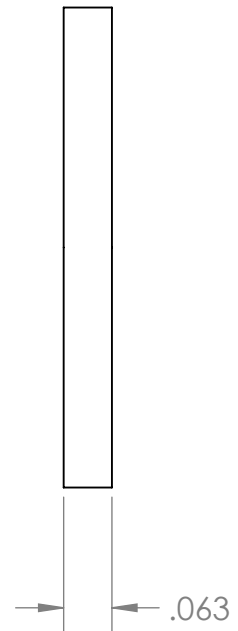
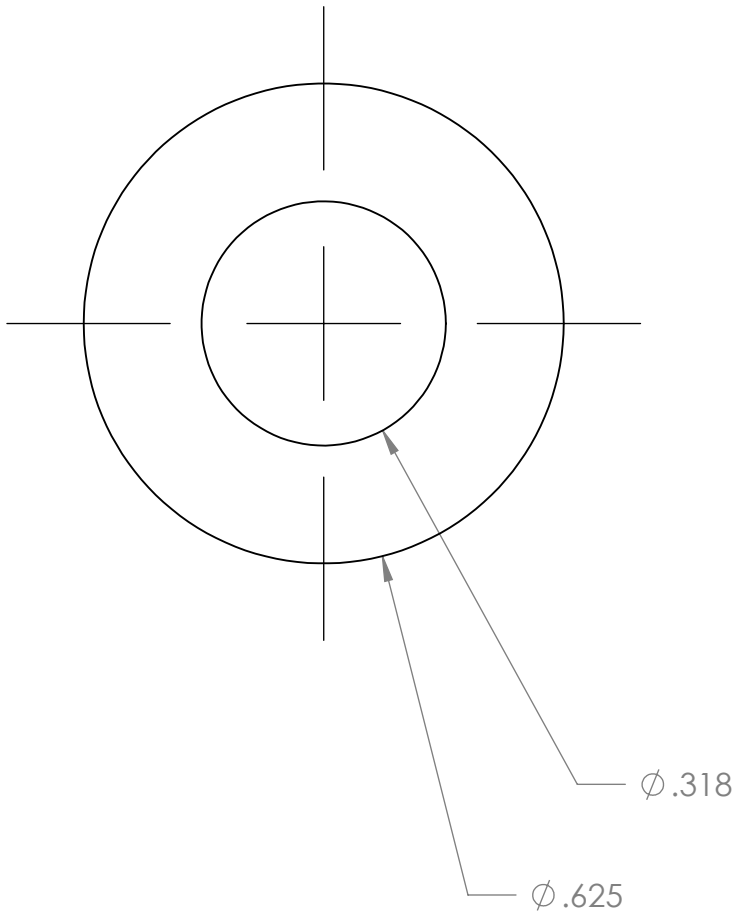

TITLE:
Roller Washer

DWG. NO.
DelrinWasher

REV: 1

SHEET 1 OF 1

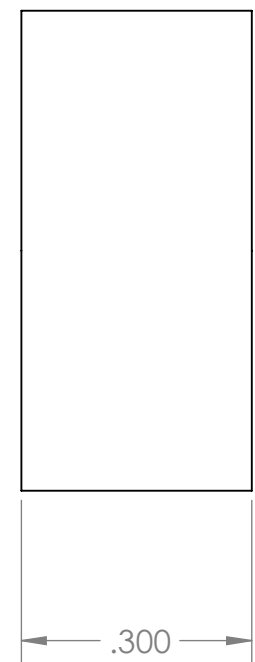
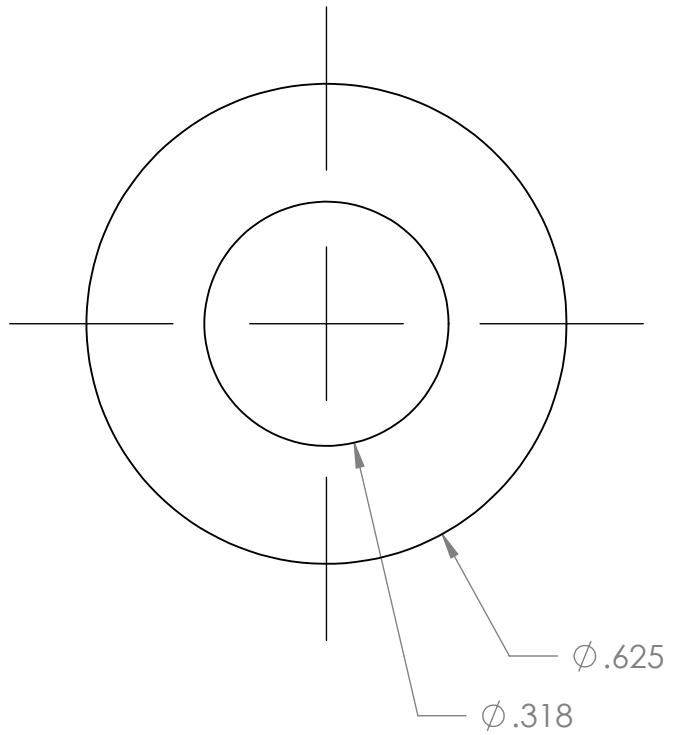

TITLE:
Roller Spacer

DWG. NO.
DelrinSpacer

REV: 1

SHEET 1 OF 1