

DARwin OP | Fabrication Manual



DARwIn OP Fabrication Manual

Created by RoMeLa at Virginia Tech

Version 1.0.0

Created 5/3/2011

Modified 5/3/2011

Principal authors:

Thanh Pham

Stephen Rouleau

Coleman Knabe

Matthew Stanford

Nolawe Woldesemayat

Mark Umansky

Justin Siegal

Austin Kim

Allison McCormack

Dante Branch

Viktor Orekhov

**THIS FABRICATION MANUAL IS TO BE USED IN
CONJUNCTION WITH THE FOLLOWING DOCUMENTS:**

DARwIn OP Wiring Manual

DARwIn OP Assembly Manual

PERMISSION IS GRANTED TO COPY, DISTRIBUTE AND/OR MODIFY THIS DOCUMENT UNDER THE TERMS OF THE CREATIVECOMMONS ATTRIBUTION-NONCOMMERCIAL-SHAREALIKE 3.0 UNPORTED LICENSE. TO VIEW A COPY OF THIS LICENSE, VISIT [HTTP://CREATIVECOMMONS.ORG/LICENSES/BY-NC-SA/3.0/](http://creativecommons.org/licenses/by-nc-sa/3.0/)



Contents

INTRODUCTION AND BACKGROUND	2
FABRICATION OVERVIEW	3
Head Assembly	4
Chest Assembly.....	5
Arm Assembly	6
Pelvis Assembly	7
Leg Assembly	8
REQUIRED TOOLS AND MATERIALS.....	9
FABRICATION PROCESS	11
CNC Milling	12
Part Removal.....	13
Deburring	14
Tapping	15
Bending.....	16
Easy Bend with a Break.....	16
Difficult Bend with a Break.....	17
Bending with a Vise.....	19
Custom Bend	20
Bending Tutorial.....	21
APPENDIX A	A-1
CNC Mill Preparation and Usage	A-2
Safety	A-2
CNC Basics.....	A-2
Initial Set-Up for CNC Machine.....	A-2
Cleaning the Mill after Use.....	A-7
APPENDIX B.....	B-1
Bending Instructions	B-2
Bending the Hand (Part 12).....	B-2
Bending the Thigh Bracket (Part 16)	B-9
Bending the Arm Actuator Mount (Part 11)	B-13
APPENDIX C.....	C-1
List of Alterations	C-2
APPENDIX D	D-1
Cable Attachment to Motor.....	D-2

INTRODUCTION AND BACKGROUND

DARwIn OP (Dynamic Anthropomorphic Robot with Intelligence - Open Platform) is an affordable, humanoid-robot platform with advanced computational power, sophisticated sensors, high payload capacity, and dynamic motion ability to enable many exciting research, education, and outreach activities. The robot's architecture is based on a series of award-winning DARwIn humanoid robots that have been in development since 2004. Sponsored by the National Science Foundation (NSF), DARwIn OP has been developed by RoMeLa at Virginia Tech in collaboration with Robotis Co.

DARwIn OP is a true open platform robot where users are encouraged to modify both the hardware and software. The robot is compatible with various programming languages including C++, LabVIEW, MATLAB, etc. With the modular design of DARwIn OP, all the hardware can be fabricated by the user with relatively inexpensive tools. Since DARwIn OP is an open source robot, the CAD files for all of its parts are available online at no cost to the user. In addition to the CAD files, the fabrication and assembly manuals are available to guide any hobbyists through the whole process for building a complete DARwIn OP robot from start to finish.

This report outlines the manufacturing process for all of the brackets on DARwIn OP. An overview on the general set-up of a CNC machine is provided. Information on sheet-metal forming and post-processing procedures such as deburring and tapping will also be included. A similar report is available to guide the user through the assembly process.

FABRICATION OVERVIEW

The DARwIn OP platform was designed to be modular so that most of its parts can be machined using conventional methods. This manual describes the process for fabricating all of the structural brackets. Figure 1 provides an illustration of all the parts making up the structural frame. The remaining components including motors, wires, electronics, and covers are available for purchase from Robotis.

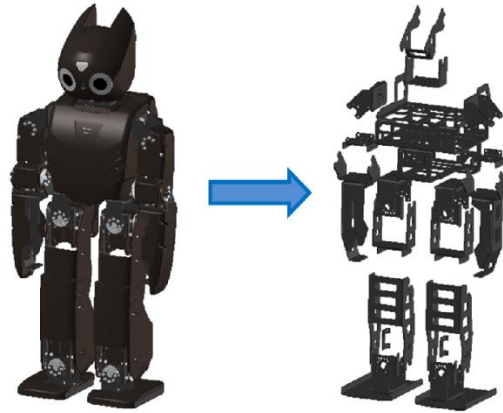

Figure 1: This manual covers the fabrication process for the structural frame of DARwIn OP.

In order to help the user better understand how the structural components come together, DARwIn OP is divided into several sub-assemblies. These sub-assemblies consist of the head, chest, arms, pelvis, and legs as shown in Figure 2. The following figures illustrate each subassembly.

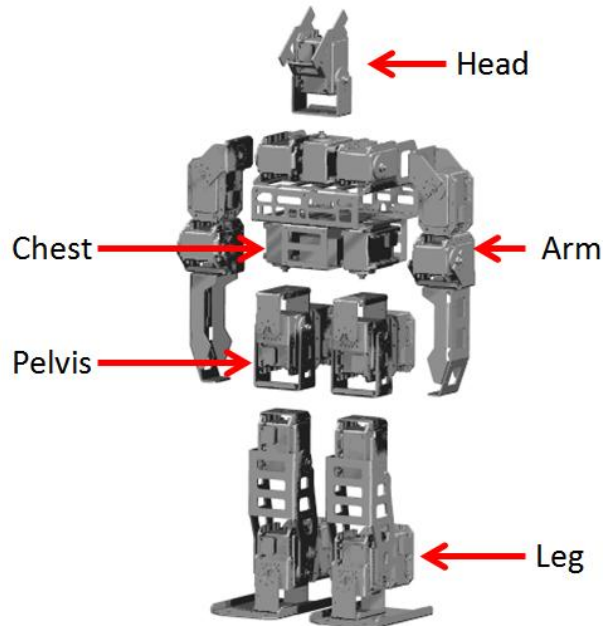

Figure 2: DARwIn OP sub-assemblies

Head Assembly

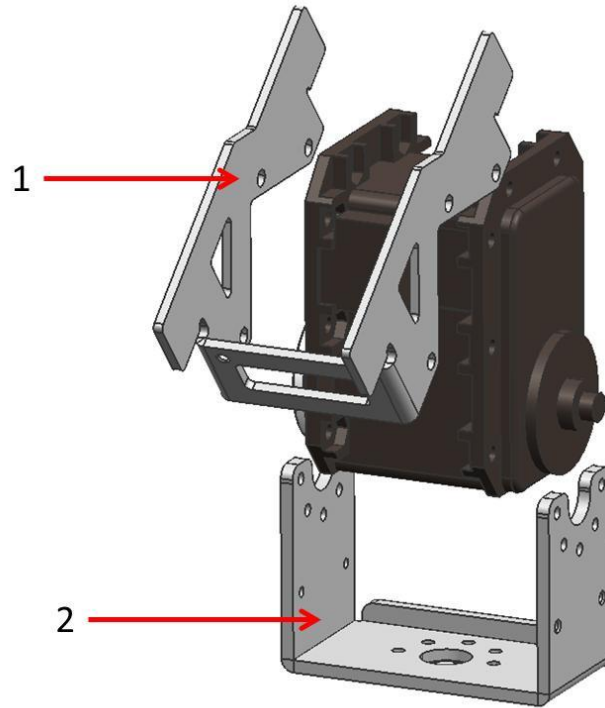

Figure 3: Head assembly

Part No.	Part Name	CAD File Name	QTY	Alum. Thickness	Recommended End Mill	Bending (Y/N)
1	Head Bracket	PR13_B01_BRKT_CAM	1	1.5 mm	3 mm	Y
2	Neck Bracket	FR07_H104	1	2 mm	3 mm	Y

Chest Assembly

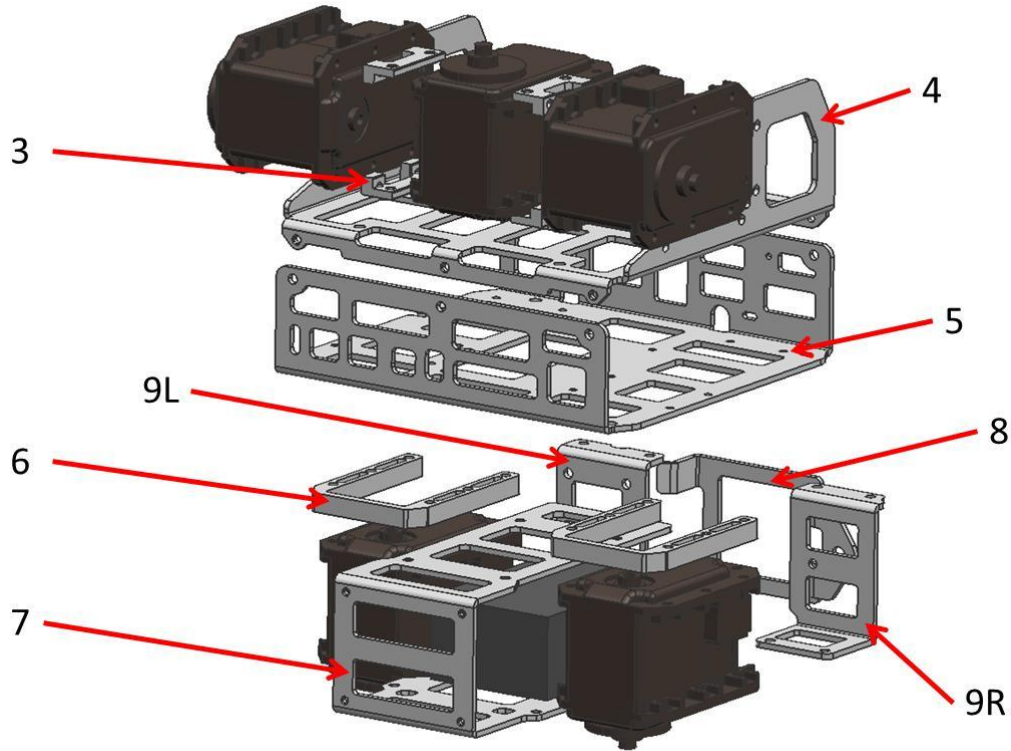

Figure 4: Chest assembly.

Part No.	Part Name	CAD File Name	QTY	Alum. Thickness	Recommended End Mill	Bending (Y/N)
3	Chest Actuator Connectors	FR07-X101	4	5 mm	2.5/3/6 mm	N
4	Upper Chest Bracket	PR13_B01_FRM_PCB_MAIN_T	1	1.5 mm	3 mm	Y
5	Lower Chest Bracket	PR13_B01_FRM_PCB_MAIN_B	1	1.5 mm	3 mm	Y
6	Mounting Bracket	PR13_B_SPACER_PELV	2	5 mm	2.5/3/6 mm	N
7	Battery Bracket	FR07_E130	1	1.5 mm	3 mm	Y
8	Battery Cover Bracket	PR13_B_FRM_CVR_BAT	1	1.5 mm	3 mm	Y
9L	Back Left Pelvic Bracket	PR13_B_BRKT_PELV_L	1	1.5 mm	3 mm	Y
9R	Back Right Pelvic Brackets	P13_B_BRKT_PELV_R	1	1.5 mm	3 mm	Y

Arm Assembly

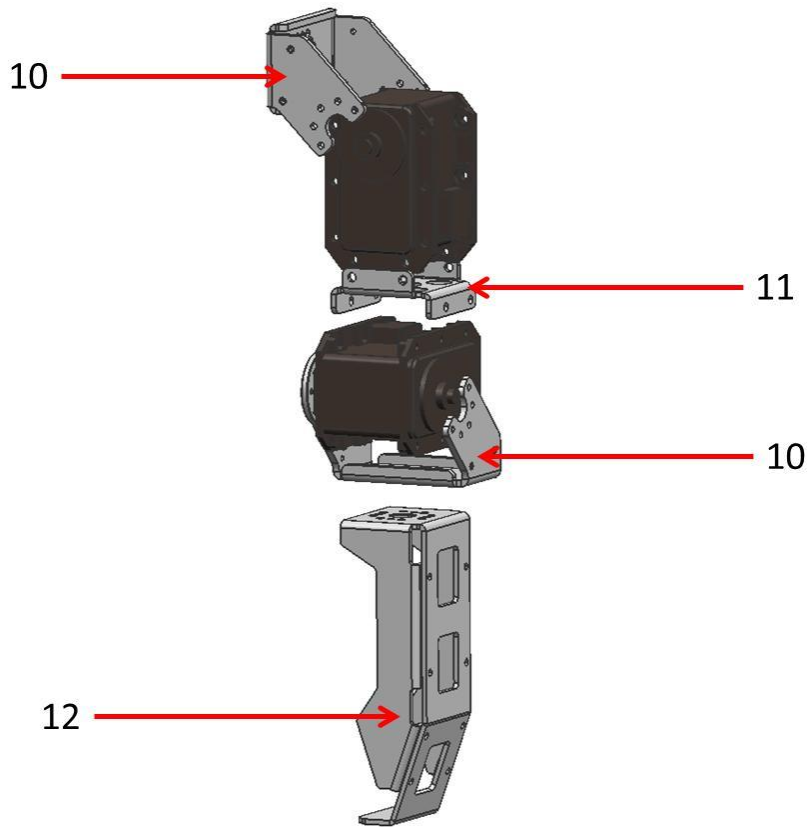

Figure 5: Arm assembly

Part No.	Part Name	CAD File Name	QTY	Alum. Thickness	Recommended End Mill	Bending (Y/N)
10	Angled Actuator Bracket	FR07_H102	4	2 mm	3 mm	Y
11	Arm Actuator Mount	FR07_SC101	2	1.5 mm	3 mm	Y
12	Hand	FR07_E180	2	1.5 mm	3 mm	Y

** Parts table reflects the parts required on both the left and right side of the robot.

Pelvis Assembly

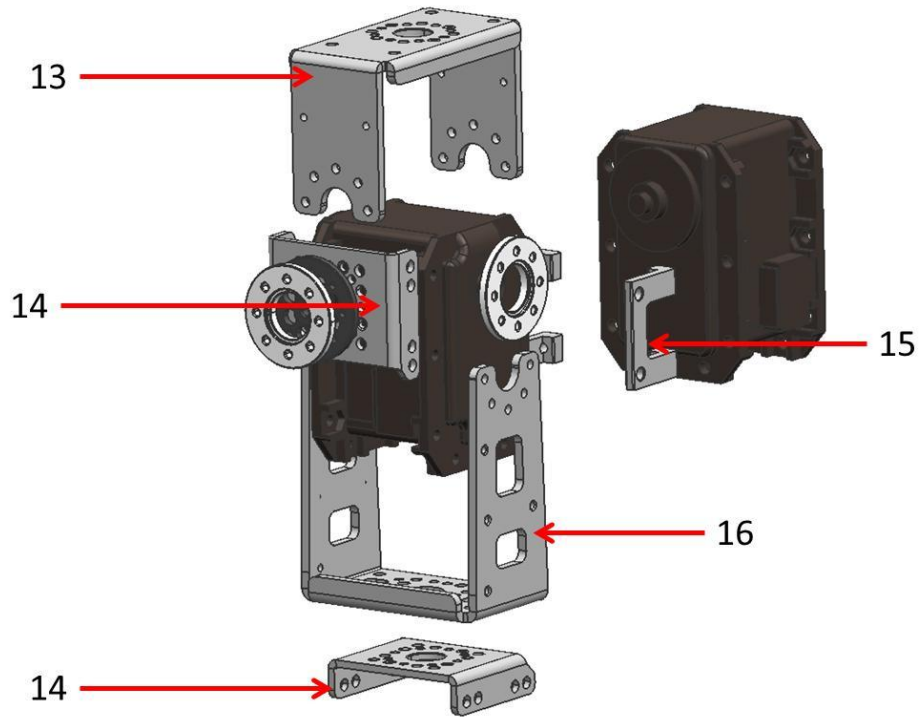

Figure 6: Pelvis assembly.

Part No.	Part Name	CAD File Name	QTY	Alum. Thickness	Recommended End mill	Bending (Y/N)
13	U-Actuator Bracket	FR07_H120	2	2 mm	3 mm	Y
14	Leg Actuator Mount	FR07_S101	4	1.5 mm	3 mm	Y
15	Actuator Connector	FR07_X102	4	5 mm	3/6 mm	Y
16	Thigh Bracket	FR07_H132	2	2 mm	3 mm	Y

** Parts table reflects the parts required on both the left and right side of the robot.

Leg Assembly

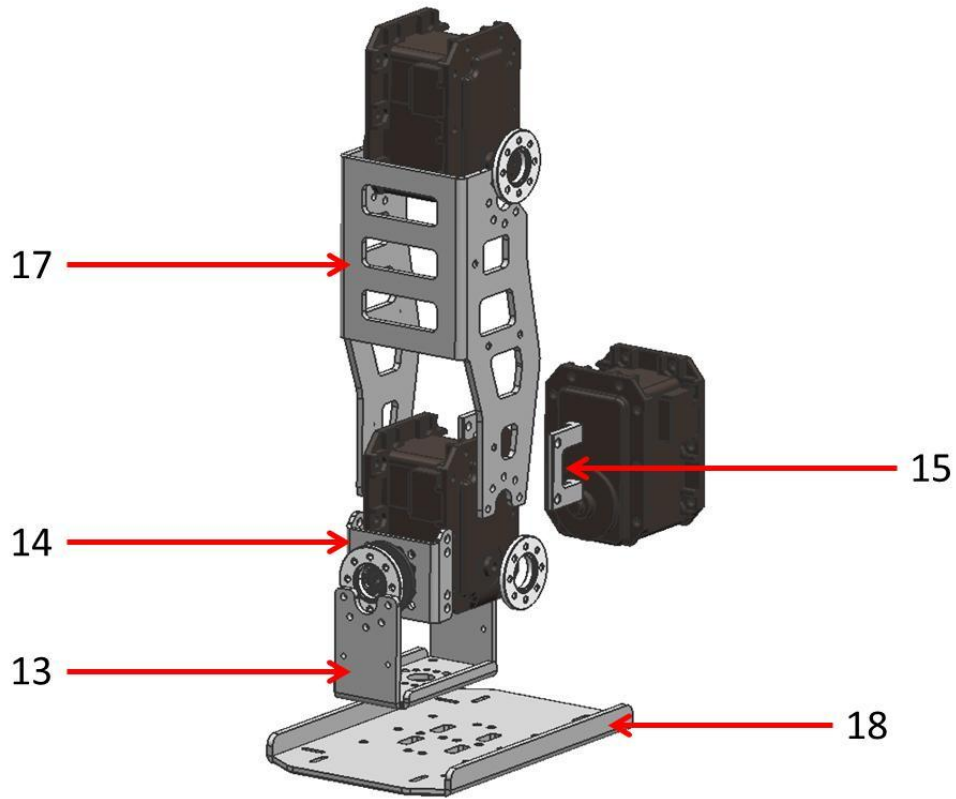

Figure 7: Leg assembly

Part No.	Part Name	CAD File Name	QTY	Alum. Thickness	Recommended End mill	Bending (Y/N)
13	U-Actuator Bracket	FR07_H120	2	2 mm	3mm	Y
14	Leg Actuator Mount	FR07_S101	2	1.5 mm	3 mm	Y
15	Actuator Connector	FR07_X102	4	5 mm	3/6 mm	Y
17	Knee Bracket	FR07_H133	2	2 mm	3 mm	Y
18	Foot	FR07_E160	2	1.5 mm	2.5/3 mm	Y

** Parts table reflects the parts required on both the left and right side of the robot.

REQUIRED TOOLS AND MATERIALS

The fabrication process for the DARwIn OP requires several different tools, which are listed below. These are recommended equipment and tools. However, it should be noted that the exact make and model of the suggested tools are not required. There are many other options at a variety of price ranges that could also be used to accommodate different budgets. Omitting equipment may increase the difficulty or time required to fabricate certain parts.

Table 1: Recommended tools for fabrication.

Recommended Tools	Vendor/Description	Model No.	Price
CNC Mill	Tormach CNC Machine	PCNC 1100	\$7480.00
Band Saw	Craftsman 12" Band Saw	137.224320	\$430.00
Dremel	Dremel 400 XPS	400	\$84.00
Vise	Pittsburg 4" Cross Slide Vise	P-538	\$40.00
Bending Break	Grizzly 24" Box and Pan Brake	G0557	\$275.00

The most important piece of equipment is a CNC machine which is used to cut all of the parts out of stock material. The machine used in this manual is a Tormach PCNC110, shown in Figure 8. Appendix A provides a tutorial on using a typical CNC machine.



Figure 8: Tormach PCNC machine used in RoMeLa for the production of the DARwIn OP.

The milling and drilling process will require various sized mill bits and drill bits as tabulated in Table 2. The chamfering mill bit is required for making score lines used during bending. Most of these parts may be purchased at McMaster-Carr. For

convenience, the McMaster part number is listed for each part in Table 2. The cost does not include spares, however, it is highly recommended that spares are readily available for end mills and drill bits, since those tend to break easily.

Table 2: Required tooling for fabrication.

Required Tooling	Estimated Cost	McMaster Part No.
2.5 mm End Mill	\$11.17	8866A242
3 mm End Mill	\$10.54	8866A252
6 mm End Mill	\$18.26	8866A322
1.6 mm Drill Bit	\$1.51	2958A38
2.05 mm Drill Bit	\$1.53	30565A234
2.6 mm Drill Bit	\$1.72	2958A56
Chamfering Mill	\$31.78	3073A47
Deburring Tool	\$9.16	4289A33
Deburring Blade	\$1.62	4289A12
Dremel Cutoff Wheel	\$3.82	2499A31
Dremel Grinding Bit	\$4.98	4919A779
Tap Handle	\$4.77	25605A63
2 mm Tap	\$13.96	8305A77
2.5 mm Tap	\$8.84	8305A11
Total	\$123.66	

The majority of the DARwIn OP parts should be fabricated from 5052 aluminum. This alloy was selected for its formability and strength. The parts were originally designed to be fabricated with aluminum sheets with thicknesses of 1.5 mm and 2 mm. However, if stock sold in metric units is hard to find, 0.0625” and 0.08” sheets may be substituted instead. In some cases, difficult to bend parts can be made out of 3003 series aluminum sheets. This type of alloy has better formability than the 5052 aluminum, but it is considerably weaker.

Table 3: Aluminum stock required for fabrication.

Aluminum Type	Thickness	Size	QTY	Unit Price	Total Price	McMaster Part No.
5052	0.0625" (1.5 mm)	12" x 12"	3	\$18.11	\$54.33	8202K13
5052	0.08" (2 mm)	12" x 12"	2	\$10.82	\$21.64	88895K35
5052	0.25"	12"x12"	1	\$27.76	\$27.76	8199K18
Total					\$103.73	

FABRICATION PROCESS

The DARwIn OP fabrication process is divided into five sections: milling, part removal, deburring, tapping, and bending. The milling process includes any processes that must be completed using a CNC machine. Once the parts are cut from the sheet, the part removal process will require a band saw to sever the checks (the small connectors holding the milled parts to the original sheet). However, the freed parts will not be in the final form until they are deburred and bent to the final shape for assembly. A bending break is recommended to perform the bending operation. In addition, certain parts have holes that will need to be tapped. For this process, a tap handle and the appropriate tap bit will be necessary for creating all threaded holes.



CNC Mill Preparation and Usage

CNC Toolpaths for each custom fabricated part must be made prior to milling. It is highly recommended that the following order be used during machining.

- Facing
- Scoring
- Drilling
- Pockets
- Final Cut-out

12



Part Removal

Use a band saw to cut the parts free from the surrounding scrap sheet metal.

13



Deburring and Tapping

Use a deburring tool to remove all sharp edges from the custom fabricated parts for safety.

14



Bending

We recommend a bending break to bend the custom-fabricated parts to 90 ° angles (bent at the pre-machined bending relief grooves).

16

CNC Milling

CNC machines use a programming language called G-Code which is a list of commands that tells the machine what actions to perform and where to go. A complete set of G-Code commands is called a tool path. Tool paths can be generated manually or by using a CAM (Computer Aided Manufacturing) package. Many of the DARwIn OP parts are simple enough to code by hand, but a CAM package is very highly recommended. All of the OP parts are made from bent sheet metal and then bent into the final form, as shown in Figure 9. 3-D models as well as 2-D layouts are available for each part. The 2-D layout will have scoring lines already modeled in to mark the fold line.

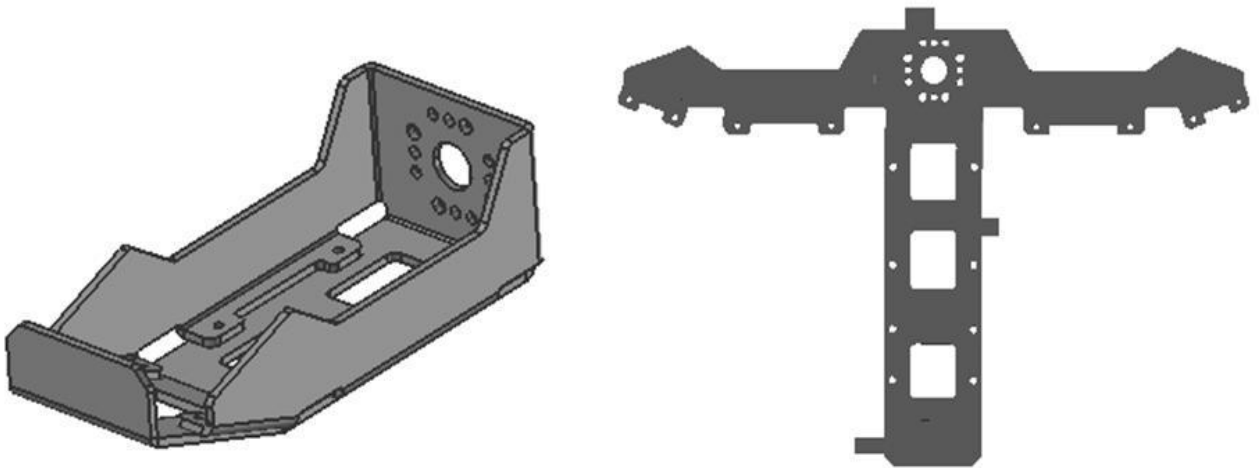

Figure 9: DARwIn OP hand shown in the final 3-D form and unbent (2-D) form.

Depending on the milling area of the CNC machine, it may be desirable to generate an array of parts on a single sheet of aluminum as shown in Figure 10. This will reduce the amount of material used and the overall setup and machining time.

The order of the milling operation is very important in developing the tool paths. In general, it is desirable to perform the milling operation in the following order: facing, scoring, drilling, pocketing, and final cut-out. The idea behind this order is to reduce the amount of stress placed on the parts during machining. The operation that would yield the most stress on the part should be done last in order to reduce the likelihood of a part breaking during the middle of the milling operation. The general step-by-step instructions on how to set up the Tormach PCNC 1100 for milling operation are presented in Appendix A.

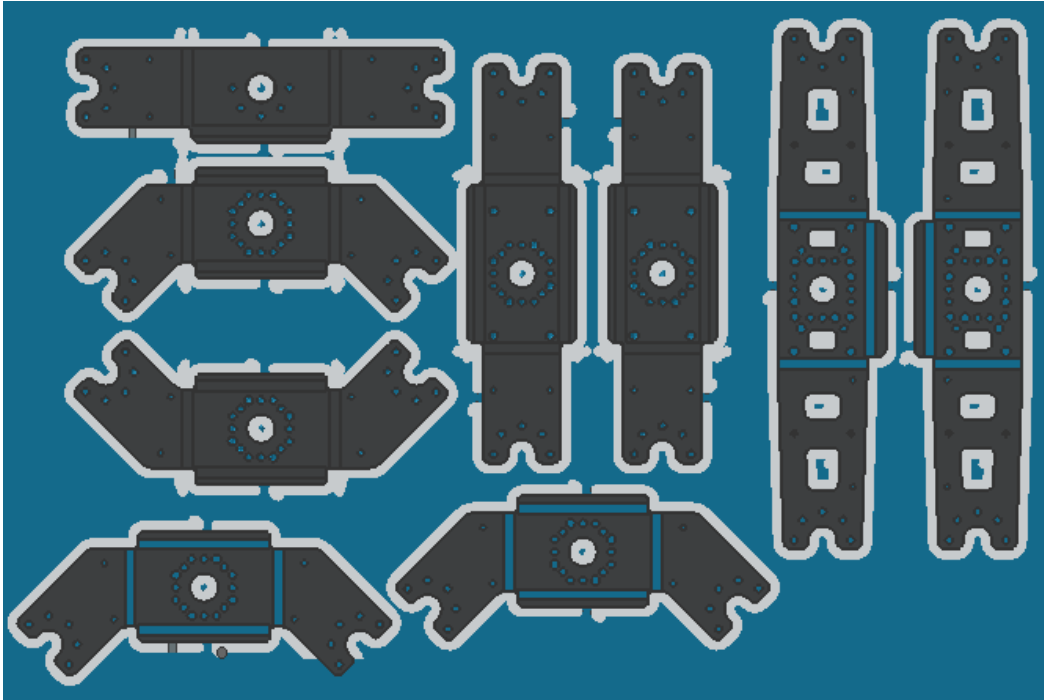

Figure 10: Typical layout of components for tool path generation.

Part Removal

At the end of the milling operation, the part should still be held in place by checks. Checks are thin tabs that prevent the part from being unconstrained. To reduce the amount of finishing work, the checks should be cut as close to the actual part as possible without cutting into the actual part.

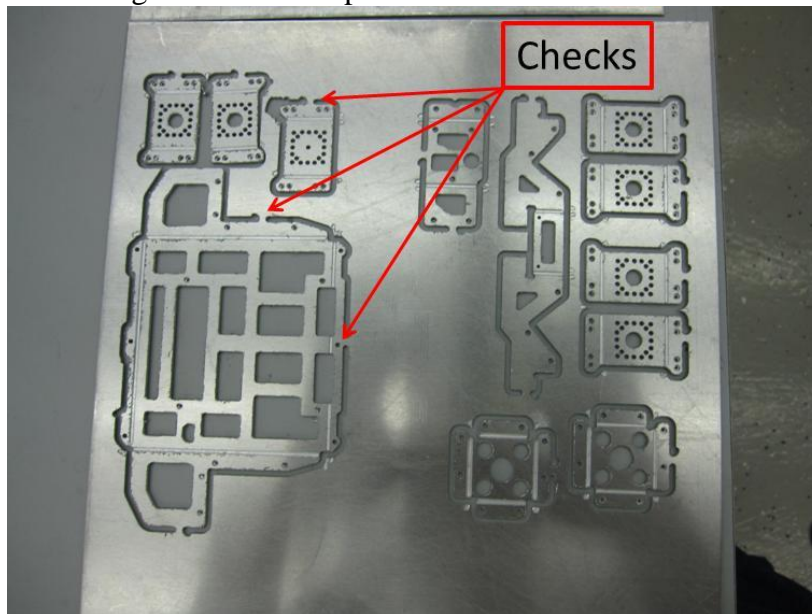

Figure 11: Sample parts with checks used to constrain the parts to the aluminum sheet.

A standard band saw equipped with a metal cutting blade or a Dremel tool can be used for cutting the checks out. When using the band saw, ensure that the blade is properly tensioned. Plan the blade paths for the part removal before performing the actual operation. The blade can be difficult to turn while cutting into the metal so it is best to keep a straight entrance/exit blade path. Perform relief cuts if necessary (See Figure 12). When making the final cut to free the part from the stock aluminum, hold both the part and the aluminum sheet to keep the part from flying off the table.

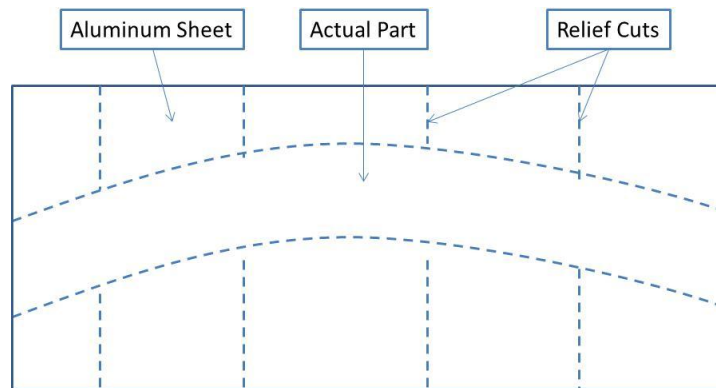

Figure 12: For parts with curves, relief cuts may be needed to prevent excessive bending of the band saw blade.

Deburring

Deburring is a finishing method used to remove burrs created during the machining operations. This is an important part of the fabrication process because small metal fragments can harm electronic components and sharp edges can cut wires and are a safety hazard. The deburring hand tool shown in Figure 13 has a knife-like edge that is pushed around the part to scrape and cut away any of the metal fragments. By the end of this process the piece should look clean on all of the edges and the edges should feel smooth. This process should not take much material off from the part itself but rather the metal fragments that are undesirable.



Figure 13: A typical hand deburring tool used in cleanup tasks after milling.

A Dremel tool, as shown in Figure 14, can dramatically reduce the man-hours required to finish parts. It is especially useful for removing large amounts of material such as the checks left on the part after they have been severed. A hand file can alternatively be used.



Figure 14: The Dremel with a general purpose grinding bit may useful for deburring the checks.

Tapping

Tapping is a process that forms threads in a smaller pre-drilled hole. The two most common bolts that are used for the assembly of DARwIn OP are M2 and M2.5 bolts. The diameter of the pre-drilled holes for the M2 and M2.5 bolts are 1.6 mm and 2.05 mm respectively. To perform the tapping operation, a tap handle and a tap bit are required. The correct tap bit must be used depending on the thread specification. The taps required for building the DARwIn OP are 2.0 mm and 2.5 mm tap. It is recommended that the part is clamped to a stable surface or in a vise during the tapping operation. Rotate the tap handle clockwise into the hole until a resistance is felt. This resistance indicates that there is a build-up of chips between the tap and the newly threaded holes. To break up the chips, simply rotate the tap handle counterclockwise half a rotation before continuing. A good method to use is to back the tap out half a turn for every rotation. It is highly recommended that a cutting fluid such as Tap Magic be used during this whole process to extend the life of the tap bit and ensure smooth threading. Take precautions to make sure that the tap is held perpendicular to the face of the part. This is crucial to ensure that parts mate properly during assembly.



Figure 15: (Left) Tap handle after it has been attached to the appropriate tap bit. (Right) The result of a tapped hole.

Bending

Many of the brackets on DARwIn OP use bent geometry. The following section will provide an overview of four different methods used to bend the parts into the final shape. Different methods are presented because a particular bend may be easier to make using a particular method. Some of the more complicated parts require carefully planning the order of bends. Three of the most difficult parts are described in more detail in Appendix B. Four methods are presented below: Simple Bend with a Break, Difficult Bend with a Break, Bend with a Vise, and Custom Bend.

Easy Bend with a Break

The RoMeLa lab utilizes a box and pan break to create the complex geometry required on DARwIn OP. The break allows the user to clamp a part and manually bend it to the desired angle. However, using a bending break requires patience and practice to successfully achieve properly bent angles.

1. Clamp the part into the bending break.
 - a. Align the edge of the scoring line with the edge of the clamp (as shown in Figure 16).
 - b. Tighten the clamp until it securely holds the part. If the clamp is not secure, the part may slip and deform during the bending process.
2. Bend the part to a 90° angle.



Figure 16: A properly clamped part. Notice the scoring line is still visible outside the clamp, and the edge of this line is aligned with the edge of the clamp.

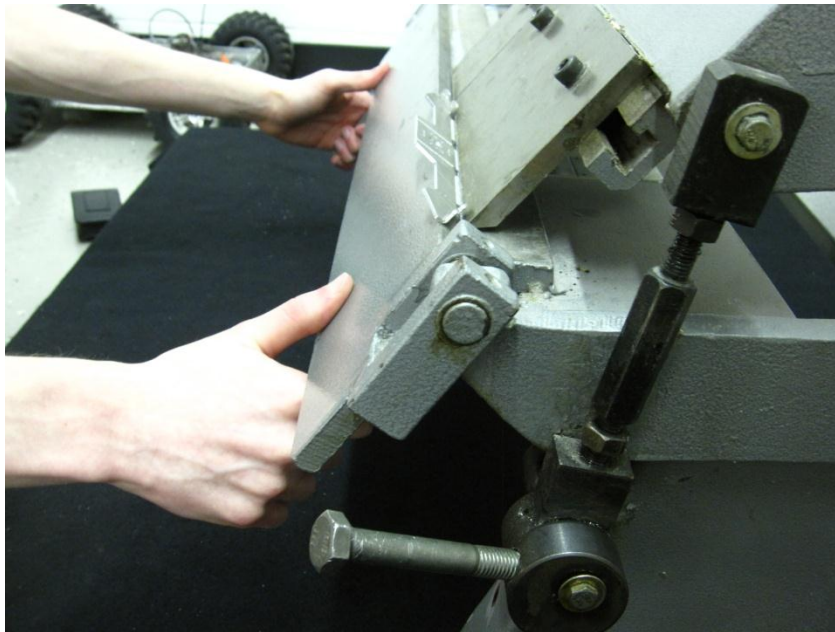

Figure 17: Proper use of a bending break. The user securely clamped the part into the bending break and has ensured there will be no obstructions resulting from other bent part.

Difficult Bend with a Break

Many breaks have the option to remove one or more of the fingers. This is useful in certain cases when the fingers would interfere with the part during bending. Figure 18 illustrates an example of the interference caused by another pre-bent tab.

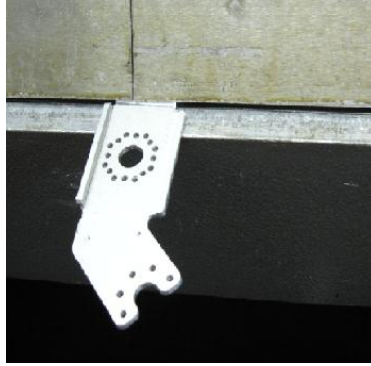

Figure 18: The pre-bent tab would prevent the part from being bent to 90°.

In order to correct this problem, the fingers can be repositioned as shown in Figure 19. Once the finger has been moved, the rest of the part could be bent using the methods from the previous section.

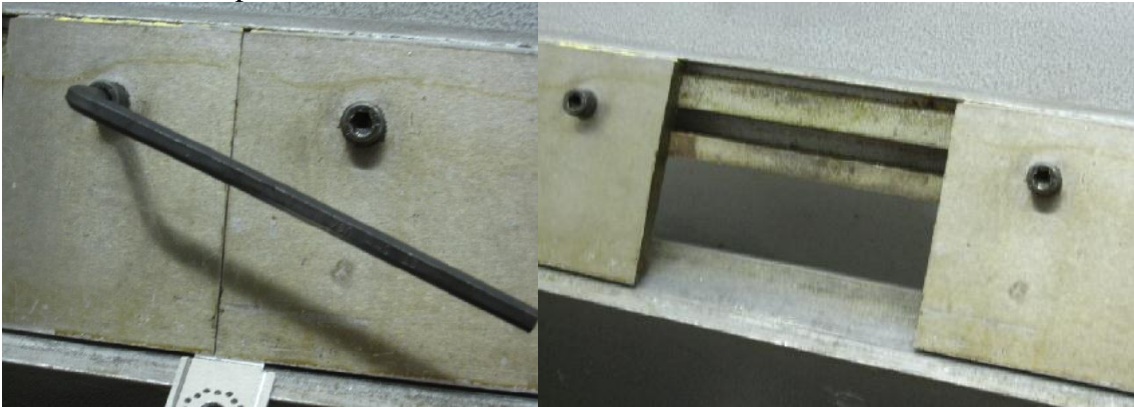

Figure 19: The fingers could be repositioned by untightening the socket head screw that locks the fingers to press.

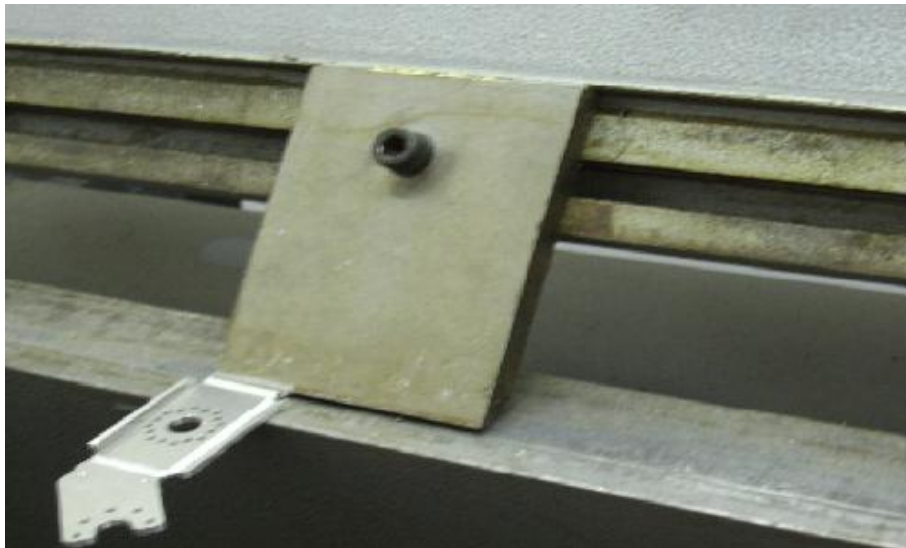

Figure 20: The finger no longer causes any obstruction to the pre-bent tab.

Bending with a Vise

Bending very small tabs can be difficult on a traditional box and pan break. For shorter tabs, a vise in combination with a compound-leverage seamer can be used.

- 1) Clamp the small tab into a vise as shown in Figure 21.

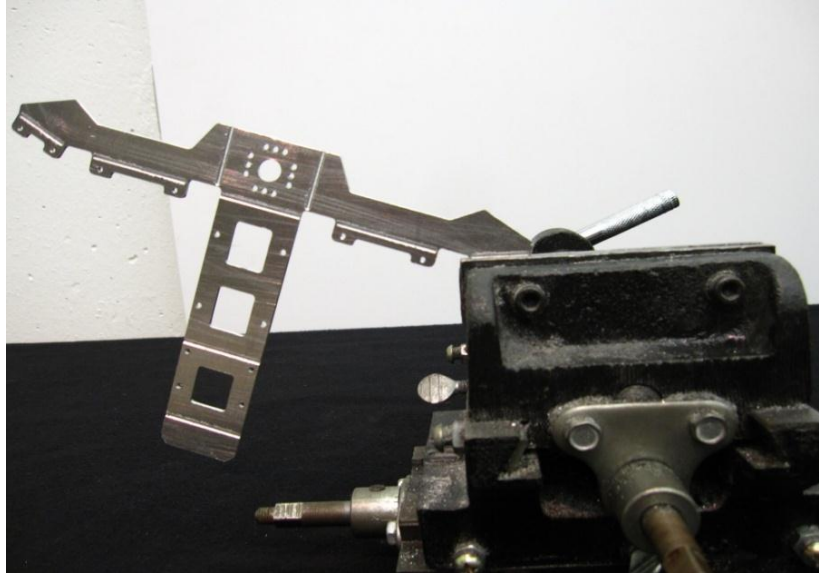

Figure 21: For small tabs that need to be bent, an alternative bending method is using a vise to clamp the part and a compound-leverage seamer to bend it.

- 2) Use a compound-leverage seamer to grip the unclamped area and bend the part towards the desired bend angle.

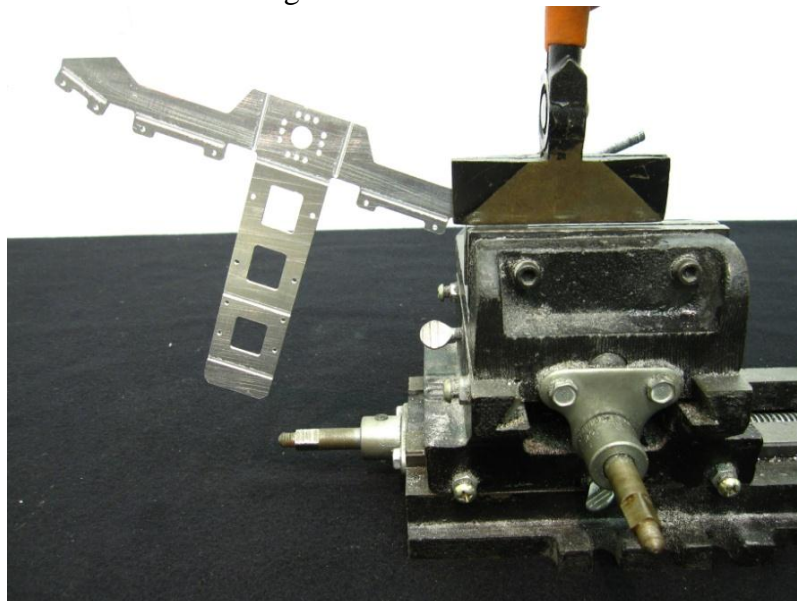

Figure 22: Use a compound-leverage seamer to grip the part for bending.

- 3) Since the seamer will likely not complete a 90° bend, a mallet and hammer can be used to complete the bend. The mallet is used to prevent marring on the aluminum. Use the hammer to hit the mallet until the bend is complete.



Figure 23: The mallet should make contact with the part in order to prevent scratches that may be caused by the impact of the hammer.

Custom Bend

The previous methods are sufficient for the majority of the bends that need to be made. However, some parts with bends in multiple planes have limited free area for clamping. For these parts, an aluminum block with the desired dimensions can be used as shown in Figure 24. The bending process in this case will again utilize a mallet and hammer as shown in Figure 25. The mallet should be in contact with the aluminum to prevent any scratches. Use the hammer to hit the mallet until the bend is complete.

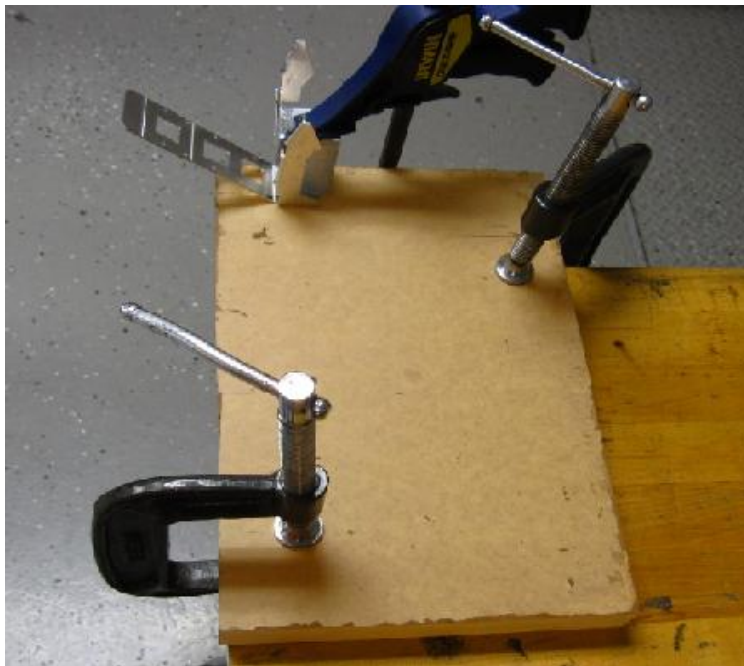

Figure 24: For parts with limited clamping area, a custom-made aluminum block may be needed to successfully clamp the part to something fixed (yellow solid plate).



Figure 25: The mallet should make contact with the part in order to prevent scratches that may be caused by the impact of the hammer.

Bending Tutorial

Three sets of bending instructions are provided in Appendix B to guide the user through the bending process for the Hand (Part No. 12), Arm Actuator Mount (Part No. 11), and the Thigh Bracket (Part No. 16). These instructions are meant for the user to get acclimated to the bending process and understand the difference between the various bending methods and the importance of the bending order.

APPENDIX A

CNC Mill Preparation and Usage

Note: *You should always consult a knowledgeable expert if you are unsure on how to operate your CNC mill. This guide should not be used as the only introduction to CNC operations for a new mill operator.*

Safety

Make sure that the safety instructions listed below are well understood before starting any mill operation. The machine is very capable of damaging your parts. A CNC mill can be expensive, upwards of \$15,000; therefore precautions should be taken to prevent any damages to the machine or yourself. Most incidents can be avoided by being patient, cautious, meticulous, and knowing where the emergency stop button is located on your machine.

- 1) Always wear eye protection
- 2) For frequent users, hearing protection should be used
- 3) Do not perform any machining operations you are not comfortable with
- 4) Always keep your eyes on the part and your hand on the ESC key in case anything goes wrong
- 5) Never leave the CNC machine operating unattended

CNC Basics

The code used to run the CNC machine is called the G-Code or G&M Code. Each line consists of a command code that tells the machine where to go and what it should do. Each command code starts with the letter “G” or “M” followed by an integer and a set of coordinates or parameters. For example, the command code “G0 X1 Y2 Z3” will tell the mill to move at 60 inches per minute (IPM) to the local coordinate (1,2,3). Similarly the code “G1 X1 Y2 Z3 F15” will tell the mill to move to the x, y, z coordinates at the speed designated by “F”, in this case, at 15 IPM. The list of commands can be found in the user’s manual for the machine you are using.

For simple milling operations, the G-Code may be written by hand. For more complex operations, a tool path may be generated using any CAM (Computer Aided Manufacturing) package. Regardless of which method is used to generate the tool path, each code should be verified by running the mill in air or on wax to debug any potential issues before machining the actual part.

Initial Set-Up for CNC Machine

Note: *When making the tool path for the scoring line, it is important to note that these grooves are very sensitive to the cutting depth and could cause structural damage to your part if the cutting depth is too deep. It is recommended that the scoring line be used to mark where the bend should occur only therefore a slight indentation (~1/3 the thickness of your part) on the surface should be sufficient for this purpose.*

- 1) Check the settings on the mill to verify that the spindle is set to rotate clockwise. The machine will not cut anything if it is set to rotate counterclockwise. These settings are located on the control panel on the actual CNC machine as shown in Figure 26.



Figure 26: Control panel on the CNC machine. The button for spindle rotation is located at the bottom right corner.

- 2) Pull the “Oiler” handle to lubricate the ways and ball screws on the CNC machine. Consult your CNC user’s manual if you don’t know where this is located.



Figure 27: Pull the oiler to lubricate the ball screws on the CNC machine.

- 3) Check the coolant level on your machine to ensure that there is enough coolant to cool down your tools during operation. For best results, the coolant should look milky rather than watered down. If this is not the case, mix more coolant with water.

- 4) Turn on the mill and establish a connection with a computer.
 - a. Turn the switch located on the mill to the “ON” position and make sure the emergency stop is engaged.
 - b. Open the mill control program on the computer.
 - c. Establish a link between the computer and the mill.
- 5) Open the milling tool path in the milling program on your computer (these are often .txt files with simple commands the mill uses to cut the parts).
- 6) Secure an aluminum sheet (for your part) to the machining table with a scrap aluminum block to serve as a sacrificial plate underneath the aluminum sheet. This is done to prevent your tool from going too deep and damaging the bed of your CNC machine. It is highly recommended that a sacrificial steel plate is placed beneath the scrap aluminum plate as well. In cases where the tool manages to penetrate the aluminum plate, the steel plate will break your tool to prevent damages to your CNC machine. Ensure that everything is tightly clamped to the bed with bolts, nuts, and clamps provided with the machine as shown in Figure 28.

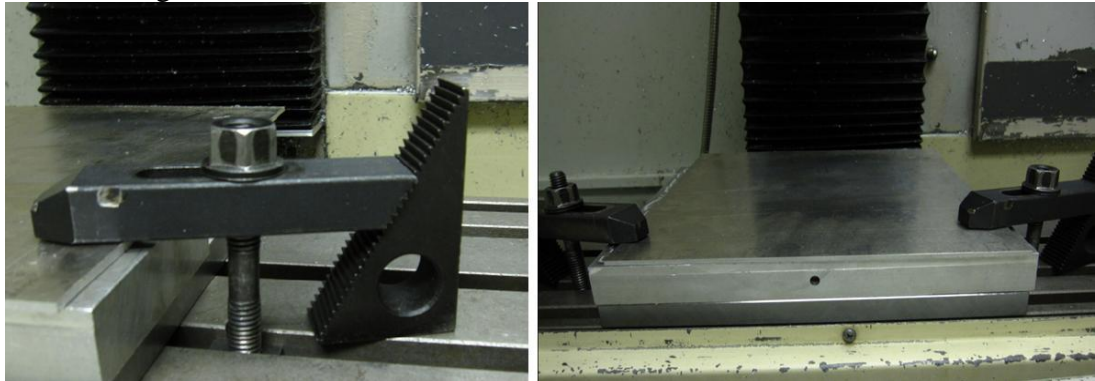

Figure 28: Aluminum sheet properly clamped to the CNC machine. Note the sacrificial aluminum plate at the bottom of the aluminum sheet.

- 7) Attach the desired tool to the CNC machine. Make sure you use a wrench to tightly secure the tool to the mill (Figure 29).

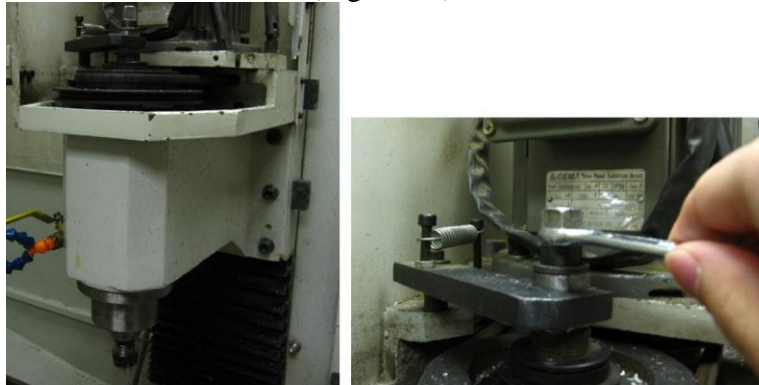

Figure 29: Ensure that the tool is secured to the CNC machine with a wrench.

- 8) Manually position the tool to the desired x- and y- zero position. To manually position the tool, use the keyboard to jog around. The arrow keys on your

keyboard will control the x and y axis. The “page up” and “page down” key will control the z-axis on your tool.

- 9) Set the x- and y- zero position in the milling program. Once the desired x and y location is reached, type in “0” in the x-coordinate box on your computer screen and press enter. Do the same for the y-coordinate (Figure 30).

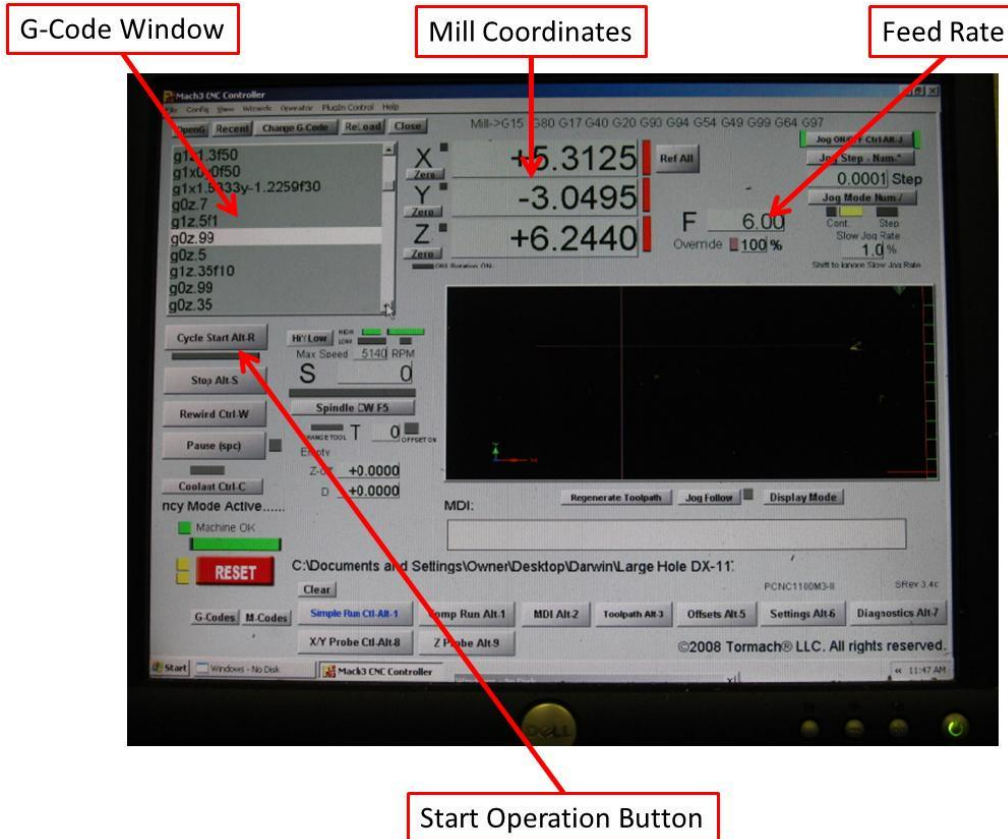

Figure 30: Control panel on the computer to control the milling operation.

- 10) Use a cylinder of known diameter (ex. a 3/8 inch drill bit) to zero the mill in the z- direction.
 - a. Using the slowest jog rate, lower the tool until the first point at which the cylinder cannot roll freely under the tool tip.
 - b. In the milling program, set the z-distance as the diameter of the cylinder (ex. if using a 3/8 inch drill bit, set the z-distance as +0.375”).

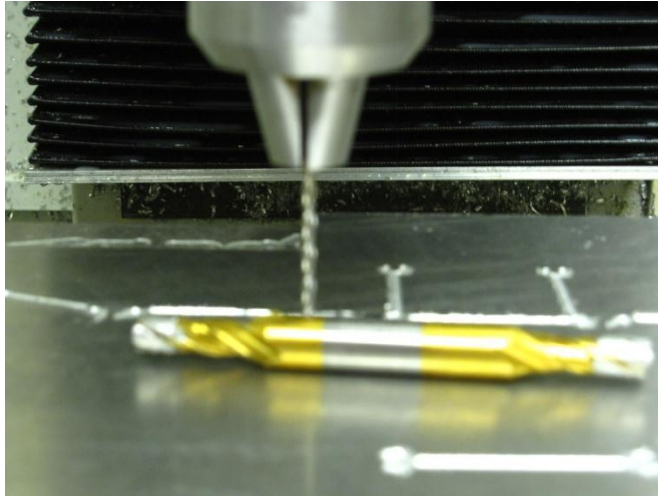

Figure 31: Use a drill bit to zero the mill in the z-direction. The point at which the drill bit can no longer roll under the tool tip is exactly the diameter of the drill bit away from the aluminum sheet.

- 11) Check to ensure that the tool path will safely cut the aluminum sheet without damaging the mill by running the mill above the aluminum sheet.
 - a. Temporarily set the z-direction zero to be about 3-4 inches above the aluminum sheet.
 - b. Run the mill without turning on the spindle using the temporary z-direction zero.
 - c. While the mill is running, check to make sure the tool will not hit any clamps or other parts of the mill and make sure the tool will not move beyond the edges of the aluminum sheet.
- 12) Set the spindle to the correct speed on the CNC machine control panel. To prevent breaking your tools during operation, make sure to consult the tooling specifications to determine the appropriate feed rate and spindle speed. For some CNC machines, the feed rate and spindle speed will be adjusted automatically based on your settings in the generated tool path while other machines will require manual adjustment of the spindle speed.
- 13) Position the coolant jet to spray the tool and turn on the coolant.



Figure 32: Make sure to have the coolant sprayed directly onto the tool to increase tool life.

- 14) Turn on the spindle.
- 15) Start the tool path on the computer to begin CNC operation.
- 16) Place your hand over an emergency stop in case the mill moves unexpectedly.
- 17) Start the milling operation and watch the operation in case anything goes wrong.

Cleaning the Mill after Use

In order to extend the life of your CNC machine, make sure you follow the steps listed below:

- 1) Vacuum the way covers after use. For hard to reach areas, use high pressure air to blow metal chips out.
- 2) Make sure the bed of the mill table is clean by removing any excess coolant. You may use pressurized air to blow the majority of the coolant off the table and use a towel to clean the rest.
- 3) Make sure to vacuum the catch tray. Do not spray air underneath the mill as this will cover the ball screw under there with aluminum chips.
- 4) All excess materials should be vacuumed up to prevent contamination of the coolant.
- 5) Remove all tooling.
- 6) Power off the machine.



APPENDIX B

Bending Instructions

The purpose of this section is to guide the user through the bending process for certain DARwIn OP parts. The hand is chosen as one example because once the user masters the techniques to make a difficult part like the hand, he/she will be prepared to complete any part on DARwIn OP. It must be noted that when bending a part, careful planning of the bending order is absolutely critical. For certain parts with complex geometry, making one bend out of order can make it almost impossible to complete the rest of the bends. The bending procedures for two additional parts (thigh bracket and motor mount) are also provided to get the users familiar with the bending process.

Bending the Hand (Part 12)

Bending Procedures:

The hand for DARwIn OP should look like the one shown below in Figure 33 after all bending operations are completed:

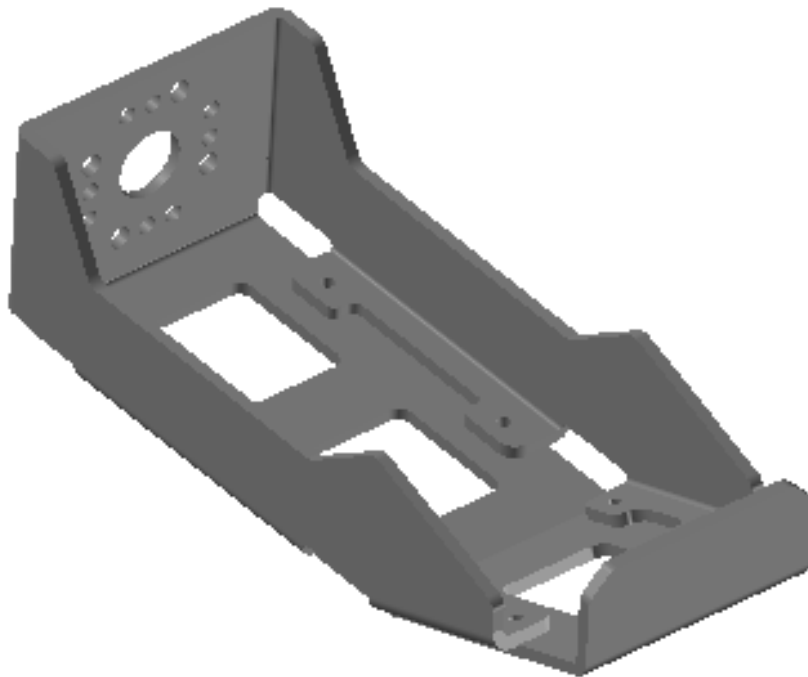

Figure 33: Completed hand for DARwIn OP.

The 2D-layout of the hand should be as follows:

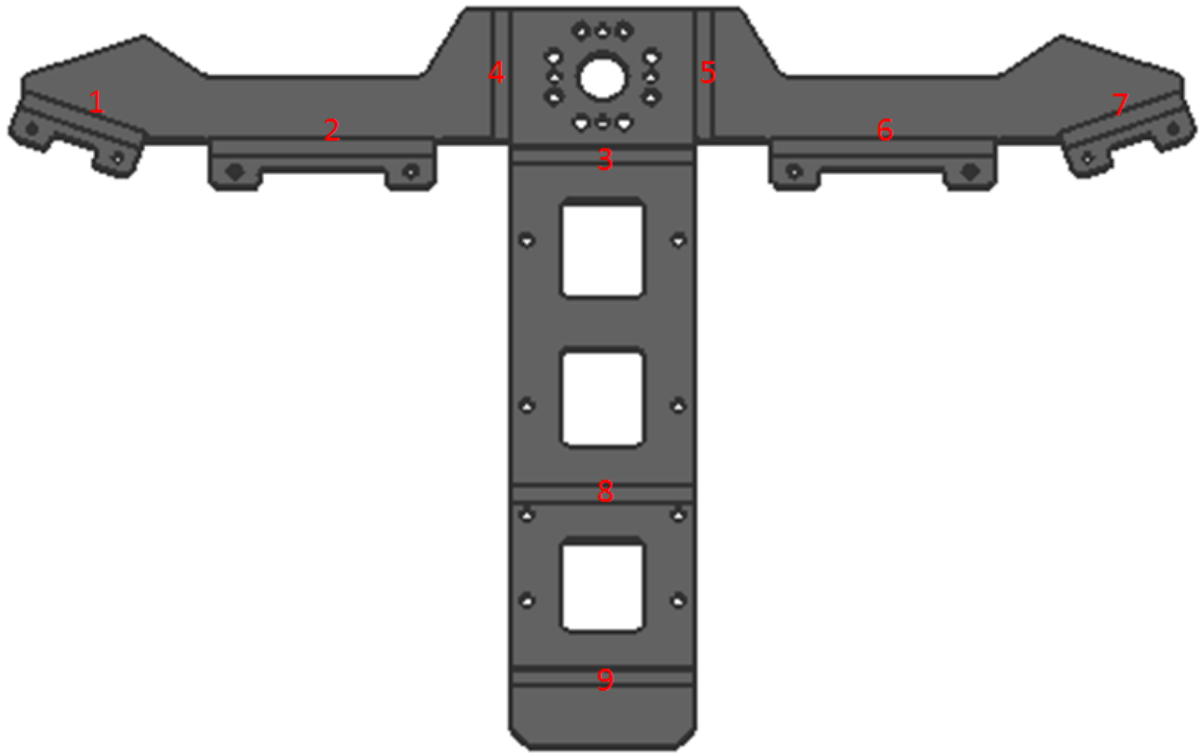
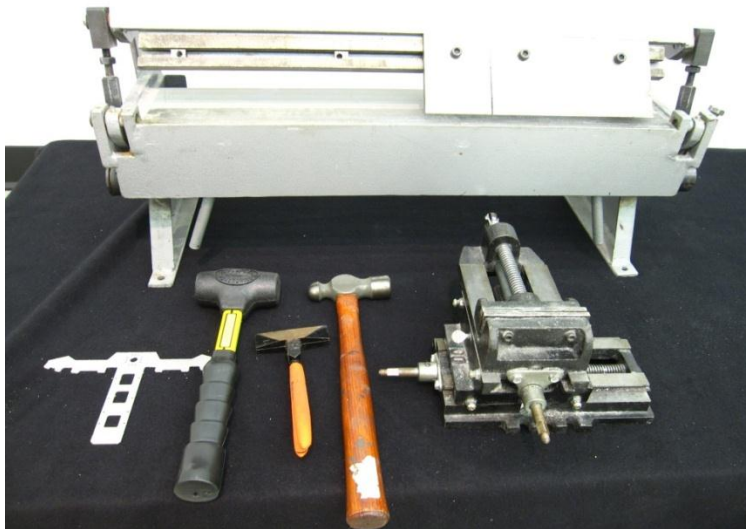

Figure 34: 2-D layout view of the hand with each bend line numbered.

To make the procedure easier to follow, each bend line will be numbered so that it could be referenced in the step-by-step directions.

- 1) Have all the bending tools prepared and ready for use.



- 2) Clamp the 2-D hand cutout to a vise at bend line 1.

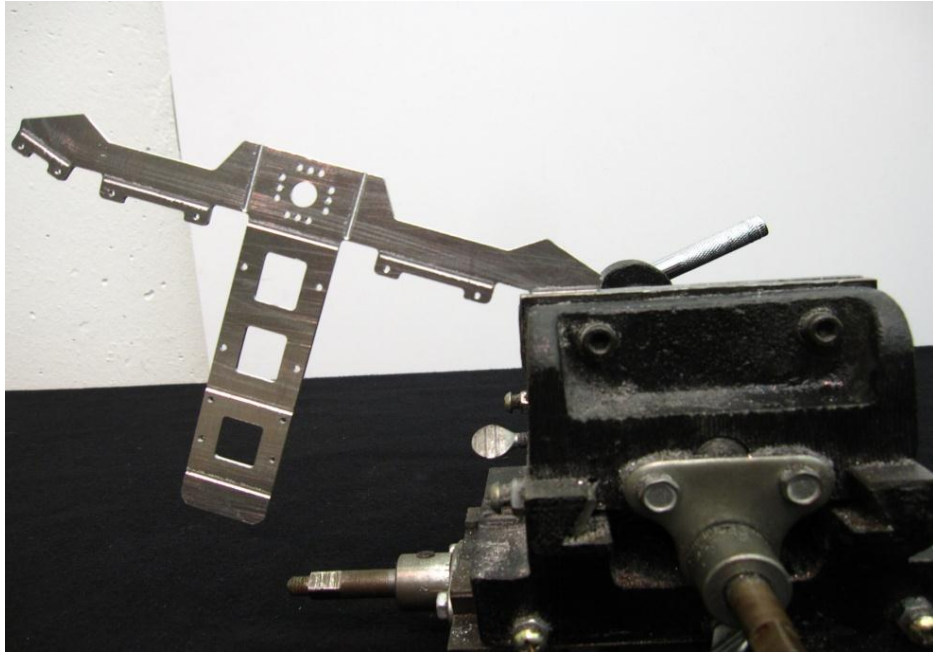

- 3) Using a compound-leverage seamer to grab the hand and slowly bend the hand to a 90 degrees angle at bend line 1.

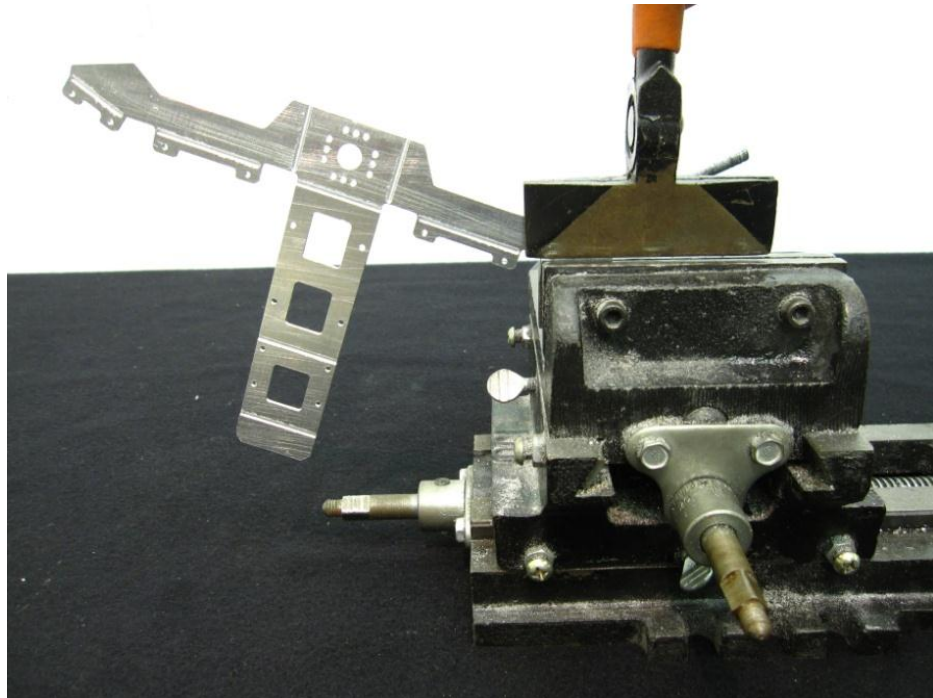

- 4) Using a mallet and hammer, hit the newly bent surface evenly to flatten out the tab at bend line 1. The mallet should be in contact with the aluminum to prevent any scratches.

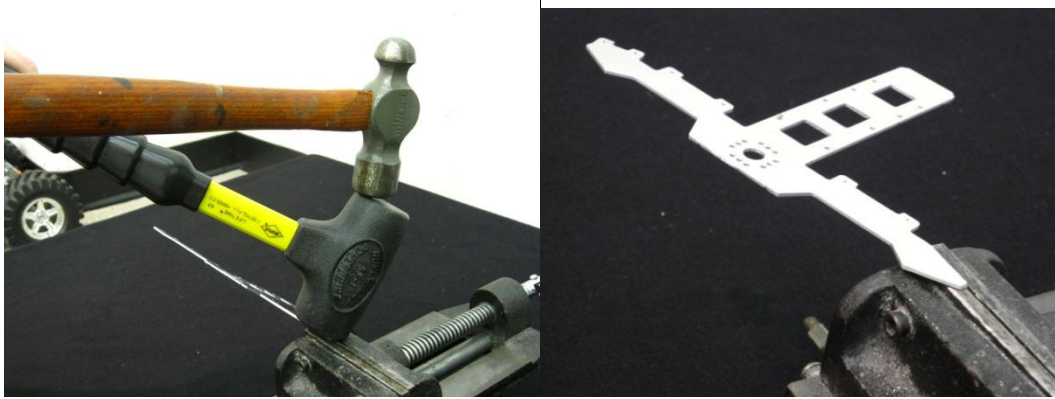

- 5) Repeat steps 1 through 4 to make the fold at bend line 7.
- 6) Clamp the hand at bend line 2, 3, and 6 to a press brake and bend the part to approximately 45 degrees.

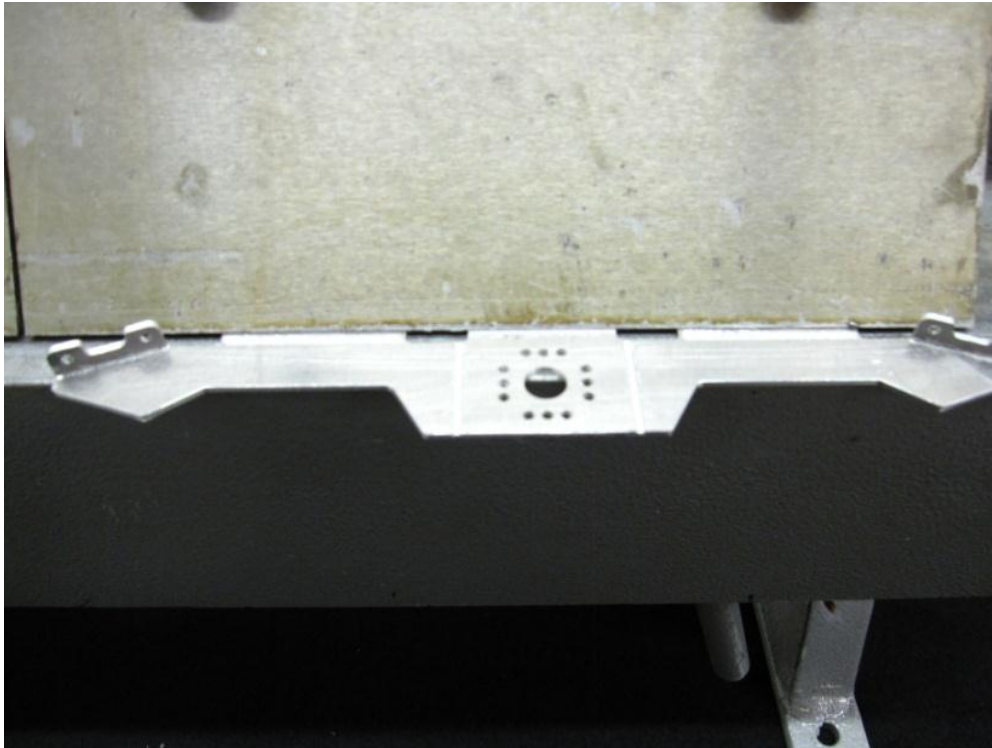

- 7) Using a vise, clamp the hand at bend line 2 so that the tab is sticking upward as shown below.

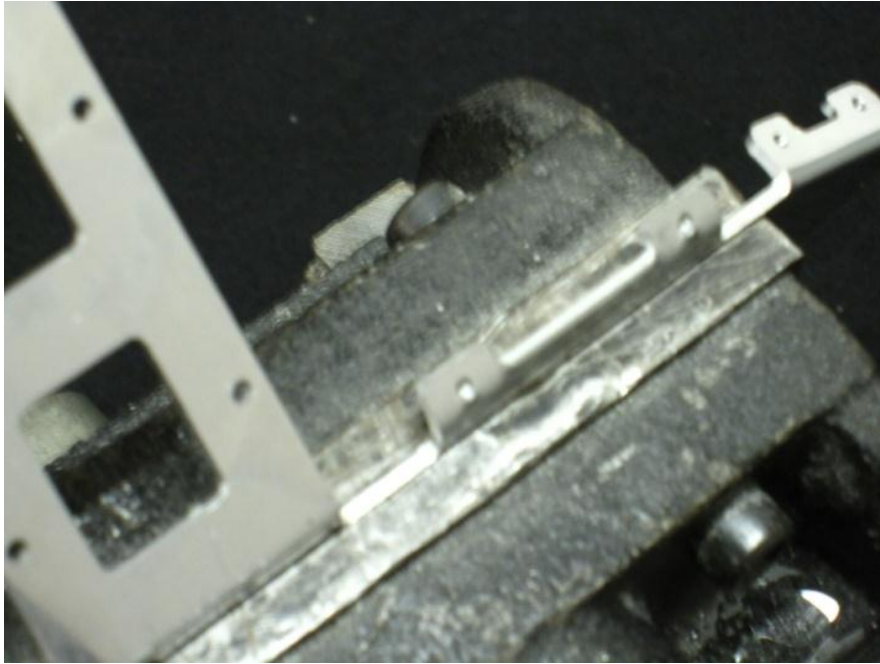

- 8) Place the flat surface of the mallet on the small tab and use a hammer with the other hand to strike on the mallet. Try to distribute the pressure evenly to bend the tap to a 90 degree angle.

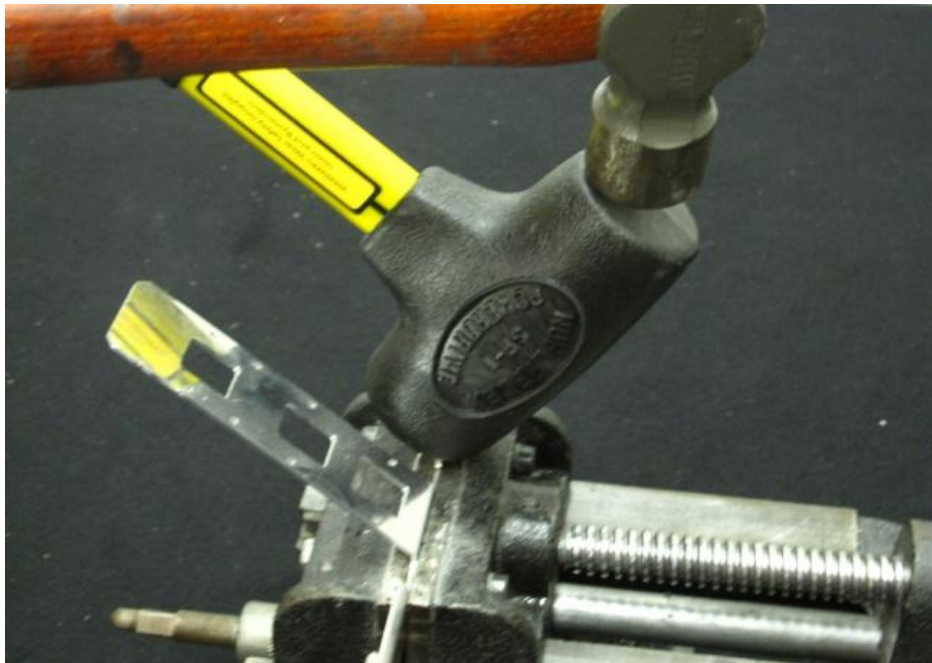

- 9) Repeat steps 7 through 8 to make a 90 degree bend at bend line 6.

- 10) Clamp the hand to the press brake at bend line 5 and bend the part to about 45 degrees.

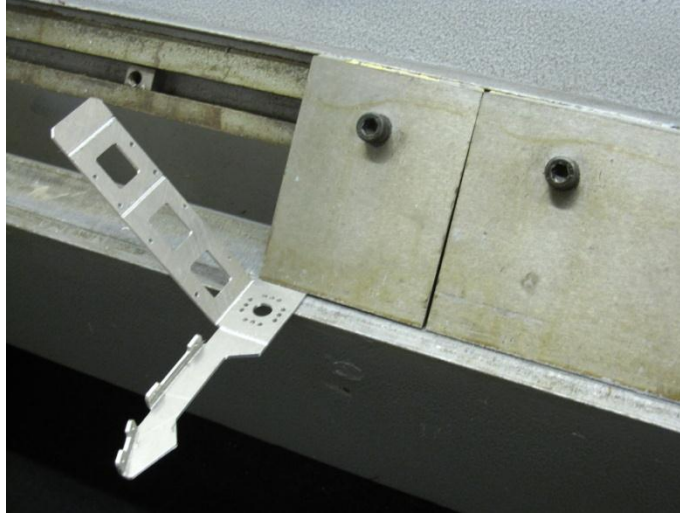

- 11) Repeat step 10 for bend line 4 but bend the hand to a full 90 degree angle.



- 12) Clamp the hand using an aluminum block and use a mallet and hammer to complete the bend from step 10. The dimension of the aluminum block should be small enough to fit in between bend line 4 and 5; however, it should also provide sufficient clamping area.



13) Clamp the hand to the press break at bend line 8 and bend it 20 degrees.

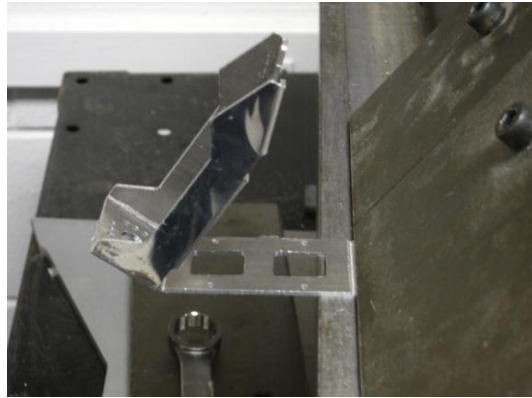

14) Clamp the hand to the press break at bend line 9 and bend it to 70 degrees.



15) Clamp the part to an aluminum block and use a mallet and hammer to make the final 90 degrees bend at bend line 3. The same aluminum block from step 12 can be used.



Bending the Thigh Bracket (Part 16)

Bending Procedures:

The thigh bracket should look like the one shown below after all bending operations are completed:

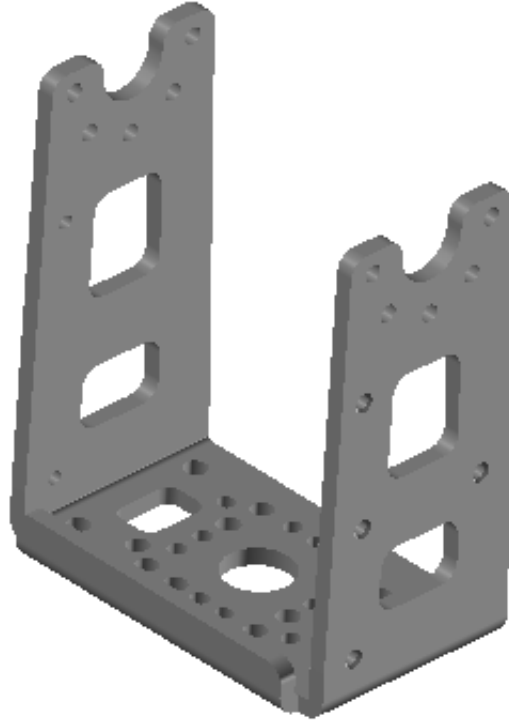

Figure 35: Completed thigh bracket

The 2D-layout of the thigh bracket should be as follows:

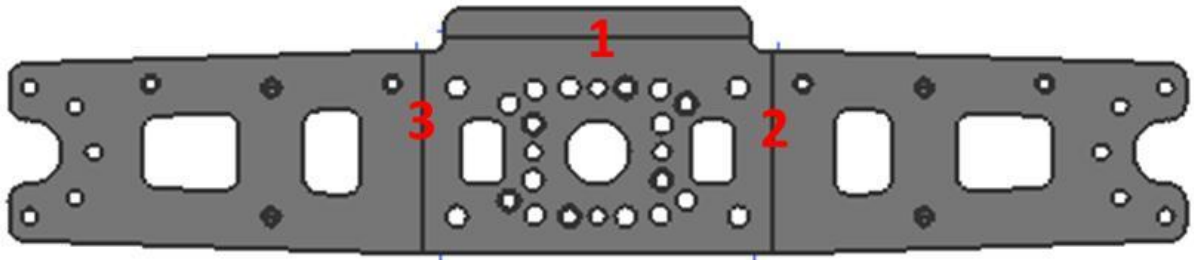
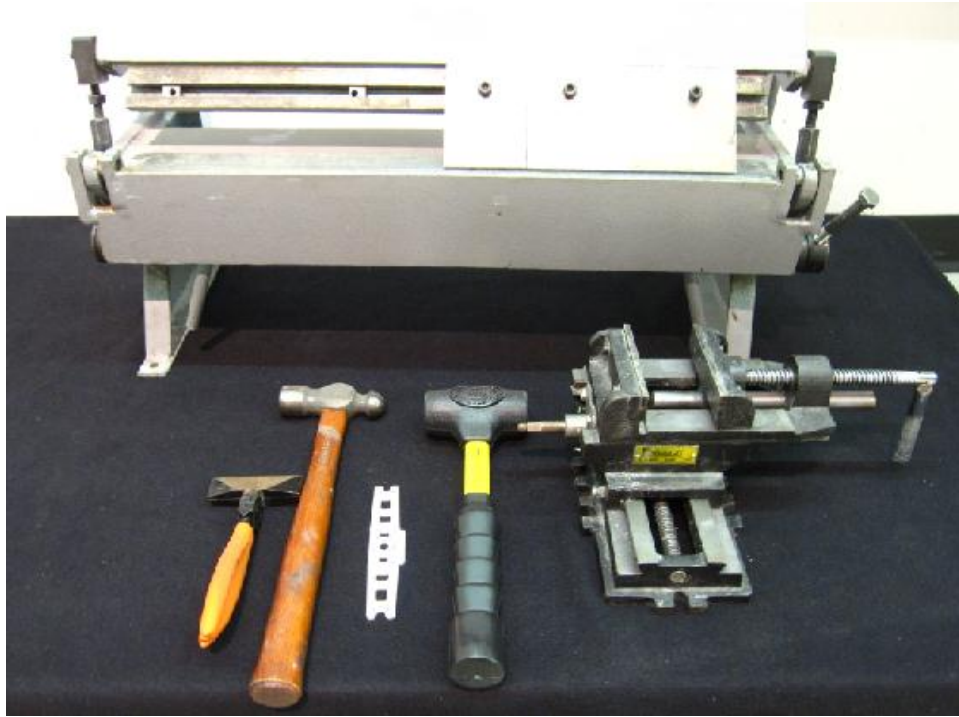
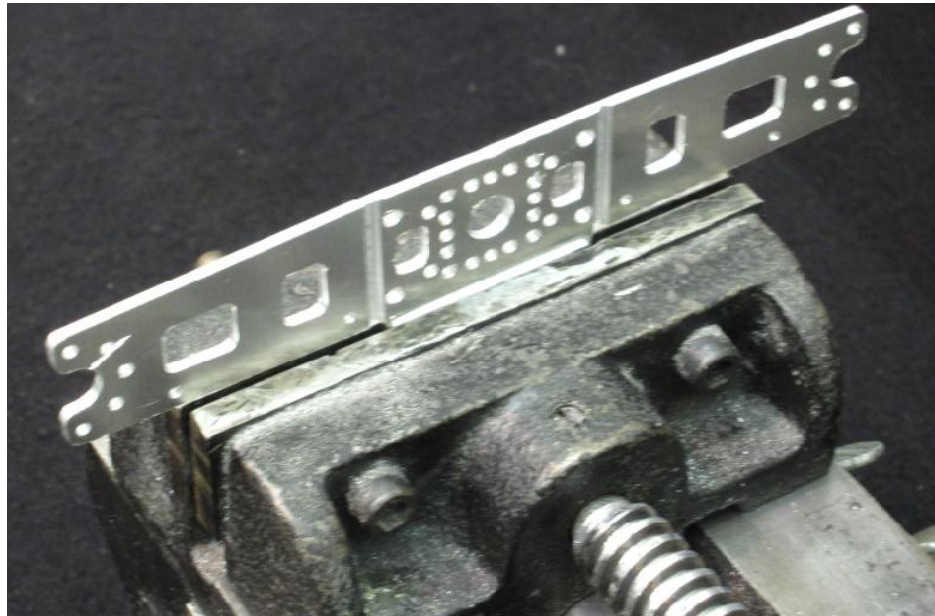

Figure 36: 2-D layout of the knee bracket with each bend line numbered.

- 1) Have all the bending tools prepared and ready for use.



- 2) Clamp the thigh bracket cutout to a vise at bend line 1.



- 3) Using a compound-leverage seamer to grab the hand and slowly bend the thigh cutout to a 90 degrees angle at bend line 1.

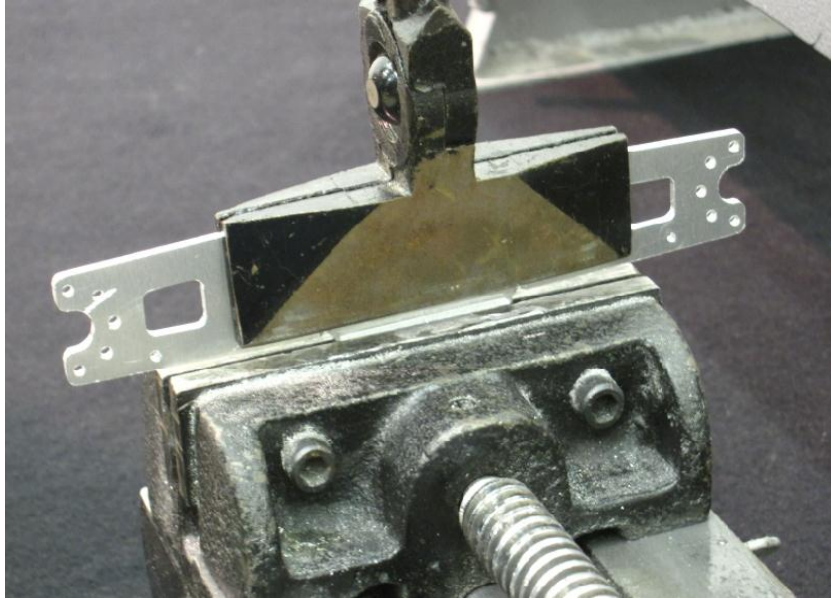

- 4) Using a mallet and hammer, hit the newly bent surface evenly to flatten out the tab at bend line 1. The mallet should be in contact with the aluminum to prevent any scratches.

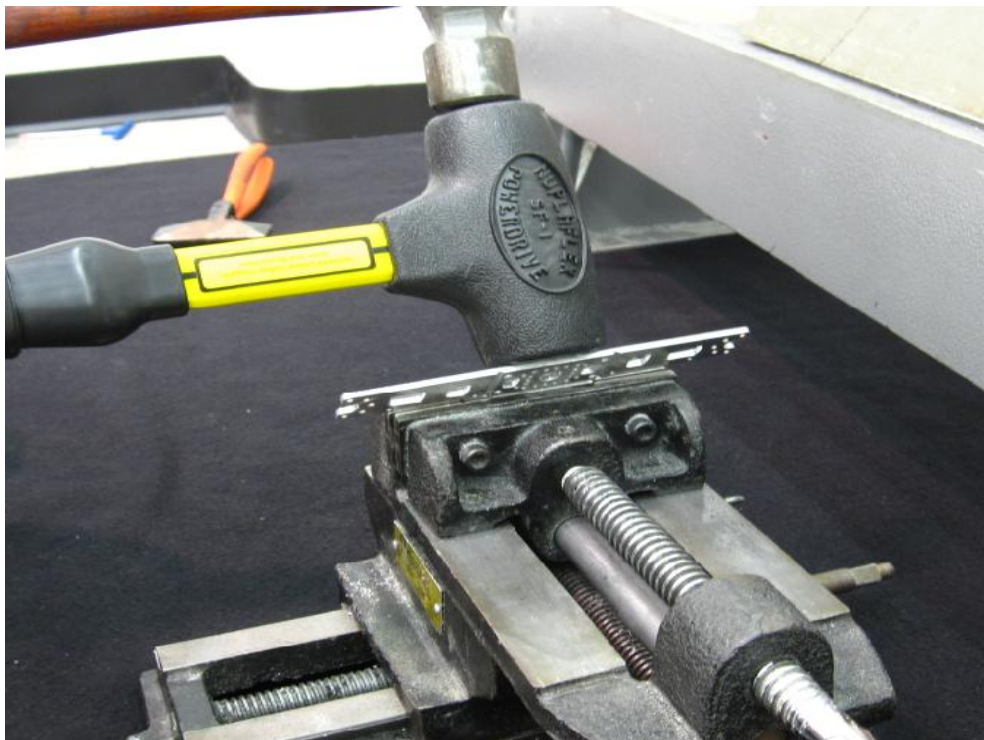

- 5) Clamp the thigh bracket at bend line 2 to a press brake to bend the part to a full 90 degrees angle.

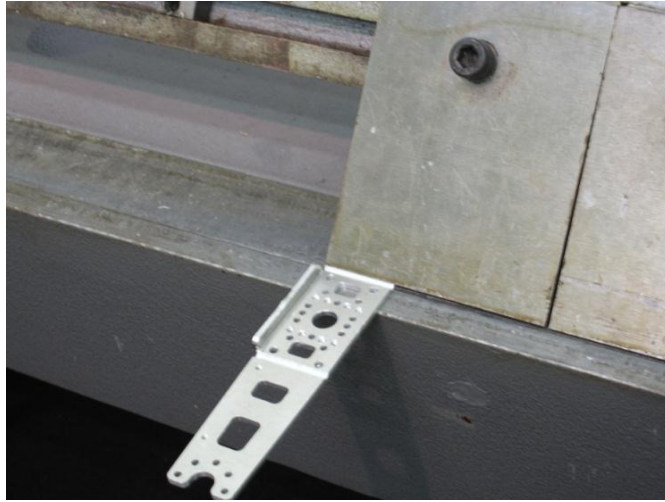

- 6) Reposition the fingers on the bending press so that the thigh could be bent on bend line 3.



- 7) Clamp the thigh bracket at bend line 3 to a press brake and bend the part until the pre-bent side touches the finger.

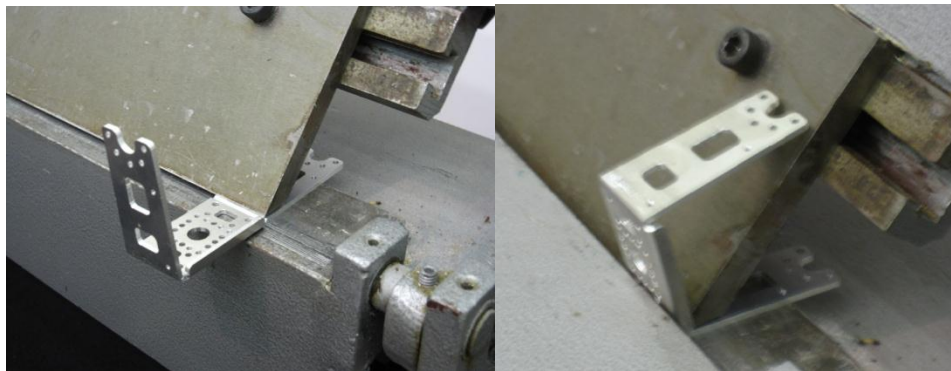

- 8) Clamp the hand using an aluminum block and use a mallet and hammer to complete the bend from step 7. The dimension of the aluminum block should be small enough to fit in between bend line 2 and 3; however, it should also provide sufficient clamping area.



Bending the Arm Actuator Mount (Part 11)

Bending Procedures:

The motor mount should look like the one shown below after all bending operations are completed:

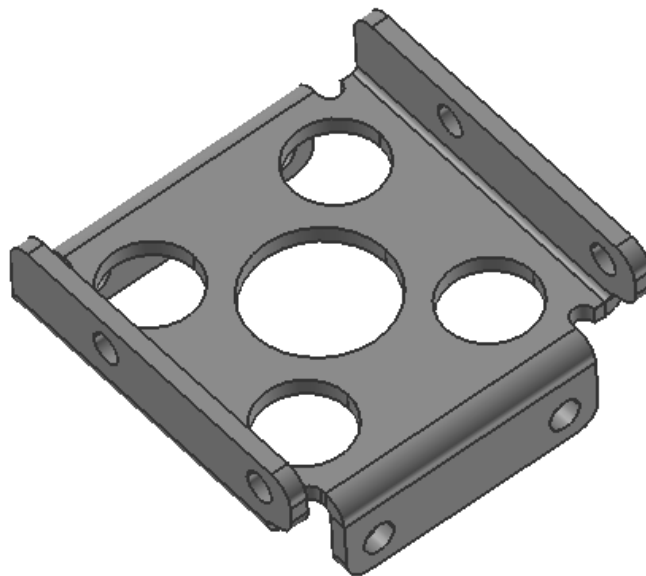

Figure 37: Completed motor mount bracket

The 2D-layout of the thigh bracket should be as follows:

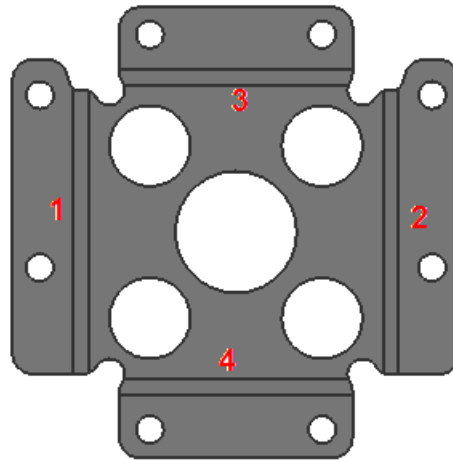

Figure 38: 2-D layout of the motor mount with each bend line numbered.

- 1) Clamp the motor mount bracket at bend line 1 to the press brake to bend the part to a full 90 degrees angle.



- 2) Clamp the motor mount bracket at bend line 2 to the press brake to bend the part to a full 90 degrees angle.



- 3) Using a vise, clamp the motor mount bracket between two small blocks of aluminum with the small tab of bend line 3 sticking upward as shown in the picture below. The dimension of the aluminum block should be small enough to fit in between bend line 1 and 2; however, it should also provide sufficient clamping area.



- 4) Use a compound leverage seamer to grip the small tab to begin the bend.



- 5) Use a hammer to flatten out the tab to a 90 degrees angle.

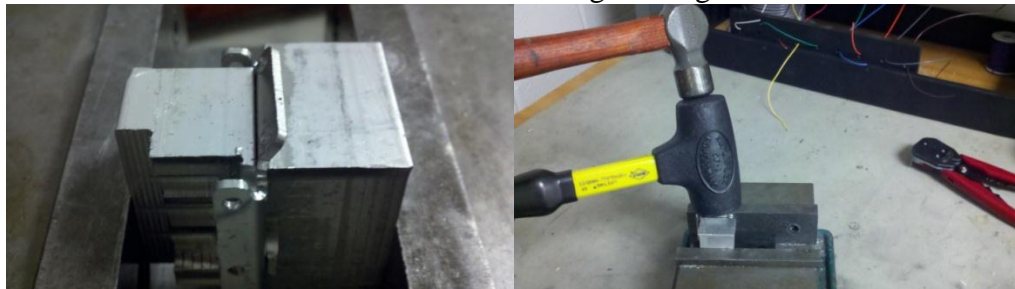

- 6) Perform steps 3-5 for bend line 4.

APPENDIX C

List of Alterations

DARwIn OP's parts were designed to be mass produced using complicated bending dies and molds in a manufacturing setting. To adapt these designs to the simplified fabrication methods presented in this manual, a number of parts were modified. For example, sharp inside corners were modified to accommodate for the radius of the end mill used. The original 3D CAD files as well as the modified 2D layouts for each part are available for the user's convenience. A parts list of each bracket and any modifications are listed below.

Part No.	Part Name	QTY	Modifications Required	Comments
1	Head Bracket	1	Yes	Pockets modified for 3mm end mill path
2	Neck Bracket	1	No	
3	Chest Actuator Connectors	4	No	
4	Upper Chest Bracket	1	No	
5	Lower Chest Bracket	1	Yes	Pockets modified for 3 mm end mill path
6	Mounting Brackets	2	No	
7	Battery Bracket	1	No	
8	Battery Cover Bracket	1	No	
9L	Black Left Pelvic Bracket	1	No	
9R	Back Right Pelvic Bracket	1	No	
10	Angled Actuator Brackets	4	Yes	Tab eliminated to simplify bending
11	Arm Actuator Mount	2	Yes	Corner radii modified for 3 mm end mill path
12	Hand	2	No	
13	U-Actuator Bracket	4	No	
14	Leg Actuator Mount	6	No	
15	Actuator Connectors	8	No	
16	Thigh Brackets	2	No	
17	Knee Bracket	2	No	
18	Foot	2	Yes	Pockets modified for 2.5 mm end mill path

APPENDIX D

Cable Attachment to Motor

The following instructions illustrate how to attach Molex connectors. These instructions can also be found in the Motor Manuals from Robotis (Section 4-5). The instructions and pictures for shortening the cable are copied from the manual here for convenience.

1. Stripping: Peel the coating of cable to the extent of about 5 mm.



2. Put the cable on the terminal as shown.



3. Press the cable and terminal using a wire former.



4. Combine the terminal to the cable tightly as shown. Solder the terminal and cable after forming to get more solid combination.



5. Insert the terminal into 4P Molex Connector.



6. When inserting the terminal, be careful with the direction of the Molex connector. Terminals should be inserted in the same way as the picture



RoMeLa

ROBOTICS & MECHANISMS LABORATORY

