



## DeltaTrix 3D Printer

by [RTegelbeckers](#) on October 21, 2013

### Table of Contents

DeltaTrix 3D Printer	1
Intro: DeltaTrix 3D Printer	2
File Downloads	2
Step 1: Background & objectives	2
Step 2: Sanity check!	3
Step 3: Most important step: the Design	3
File Downloads	5
Step 4: On the cutting edge: panels	5
Step 5: With a little help: plastic bits	7
File Downloads	9
Step 6: Buy, buy, buy: hardware & electronics	10
File Downloads	10
Step 7: Free, free, free: software	10
Step 8: Upright assembly	10
Step 9: Frame assembly	13
Step 10: Belt drive	15
Step 11: Extruder	18
Step 12: Connection rods	21
Step 13: Print head assembly	21
Step 14: Heated bed	24
Step 15: Fitting the electronics	25
Step 16: Wiring	29
Step 17: Installing software & uploading firmware	32
Step 18: Calibration	33
Step 19: First print	33
Step 20: Conclusions	34
Advertisements	34
Comments	34



Author: RTegelbeckers [author's website](#)

I am a Dutch design engineer, living in Wales (UK) and working in steel industry until recently, as my request for voluntary redundancy did get accepted. I am married, and I am a father to a little boy. I like to stay in touch with the latest developments in Computer Aided Engineering, and in work I did get to use tools such as CAD, FEA, and CFD. I now started my own company, through which I am hoping to provide for my family by designing and making stuff.

## Intro: DeltaTrix 3D Printer

The DeltaTrix 3D printer is a capable and novel 3D printer, designed to be simple in construction, yet effective in functionality. It is fully Open Source, so feel free to post improvements on the Instructables website, just don't forget to let me know in order to put links in to your own instructions...

Many thanks to Barrie for doing the video! Also thanks to Jason Mahar for publishing his song 'Pumped' as copyright free music.

Several improvements have been made since creating the initial printer. I will soon make updates to this instructable, in order to document these improvements. I will still make the files available for the initial version, but might organize them in a better way.

Update (22nd of April 2014): A new Kickstarter is to be launched today, at 18:00pm GMT: <https://www.kickstarter.com/projects/1142241325/290437546?token=4400fa2b>

A change log is attached to this first step. Current version: V0.14

Enjoy,  
Richard Tegelbeckers

PS. Just so you know, I applied for a trademark for the actual name 'DeltaTrix'. I have no problem with anyone referring to the name DeltaTrix, as long as they do not try to sell anything as being 'DeltaTrix'. By all means, refer to your thing as being compatible with DeltaTrix, just do not sell it as being a DeltaTrix. Thanks, Richard.



## File Downloads



DeltaTrix changelog 180614.txt (978 bytes)

[NOTE: When saving, if you see .tmp as the file ext, rename it to 'DeltaTrix changelog 180614.txt']

### Step 1: Background & objectives

As a mechanical design guy, I have been very interested in the ability to print the stuff I design as actual objects. In the recent past I have tried entering a few competitions on Instructables in the vain hope to win a 3D printer, but so far I have always missed my objective by a tiny amount. I have given up trying to win one by now, so I ended up designing my own. This Instructable is the result of that effort. Thanks Chris, for a signed copy of your book 'Makers'. It formed part of the inspiration to publish my design here as Open Source, instead of keeping it all to myself...

The main objective is to come up with a 3D printer that is good in performance (amongst other things, it is very fast...), looks great on a desk, and is gracious during the actual printing. It is also important to enable some experiments and upgrades in the future. I am thinking along the lines of 3D scanning and dual print heads. Do you have an idea for an improvement yourself? Publish it on Instructables and use 'DeltaTrix' as one of the keywords, so others can easily find it!

**Grand Prize (1)**



**Making a Better Mouse Trap**  
by [GerritSchmitt](#)

There are a lot of things this world needs at the moment. One of them is a better mouse trap. Mice are getting smarter every day and if we're not careful we'll end up with Planet of the Mice. Luckily, with the help of a MakerBot Replicator 2, its enormous 410 cubic inch build volume and 100 ml...

**First Prize (5)**



**The Monsters keep dancing in my head...** by [GIG40ps](#)

**Make a working lock and key** by [MatRicks](#)

**6x6x6 3D print: Delta CNC** by [RTGejbecker](#)

MakerBot's Replicator 2 is the future of the 3D printing revolution, and now, it's HERE – show us what you've got to win one FREE!

Send us your ultimate 3D design to be entered in to win a Replicator 2 to make your design a reality.

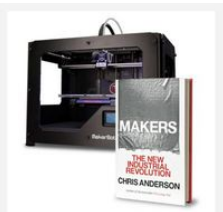

Wired magazine editor and bestselling author Chris Anderson takes you to the front lines of a new industrial revolution as today's entrepreneurs, using open source design and 3D printing, bring manufacturing to the desktop. In an age of custom-fabricated, do-it-yourself product design and creation, the collective potential of a million garage tinkerers and enthusiasts is about to be unleashed, driving a resurgence of American manufacturing – people like you! A generation of "Makers" using the Web's innovation model will help drive the next big wave in the global economy, as the new technologies of digital design and rapid prototyping gives everyone the power to invent – creating "the long tail of things".

MakerBot's Replicator 2 is the future of the 3D printing revolution, and now, it's HERE – show us what you've got to win one FREE!

Send us your ultimate 3D design to be entered in to win a Replicator 2 to make your design a reality.

## Step 2: Sanity check!

If you would like to start with 3D printing by building your own 3D printer, be aware! You will be in for a hell of a journey, with many obstacles to concur. However, being able to think something up, modelling it up and then printing it as a real object, is a very satisfying thing to do. Warning: do not mention too often to friends you have a 3D printer, as you will end up printing all kinds of crap for them...

I obtained the photo from: <http://pix.alaporte.net/pub/d/38469-1/Belief+Doubt+Sanity+Guard.jpg>



## Step 3: Most important step: the Design

As a designer by trade, of course I would argue that the design phase is the most important phase of any project. In this case there is no exception. I have put a lot of effort in trying to eliminate issues, before starting to actually make anything. Still, after building the printer for the first time I did review several aspects, the belt drive being the main one. I tried to be too ambitious in using plain bearings on the top of the machine for guiding the backside of the timing belts. Instead I ended up using timing pulleys as idlers for the timing belts, supported by two small bearings each. Although adding to the cost of the machine, the resulting driveline is elegant and effective in operation.

I attached the native AutoCAD design file (zipped DWG file), which should form the best possible basis for anyone wanting to re-create the machine. I tried to create a universal Acis (\*.SAT) file, to be used in other CAD packages, but I was not successful so far. If anyone else is able and prepared to create a universal or alternate version of the AutoCAD design file, please provide me with the file or a link and I will include it here. Update (18th of June 2014): JoanSaga translated the AutoCAD file into Acis and Iges files, which are now attached to this step. Many thanks!!!

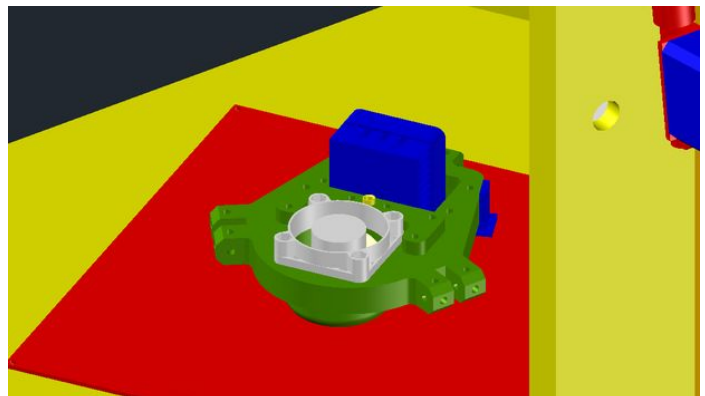

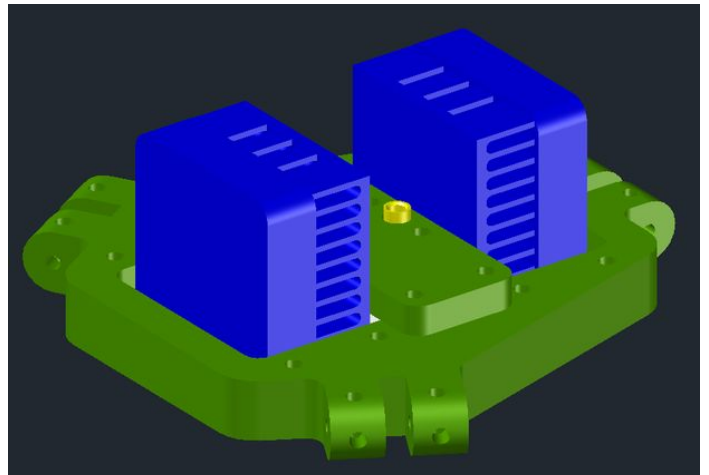
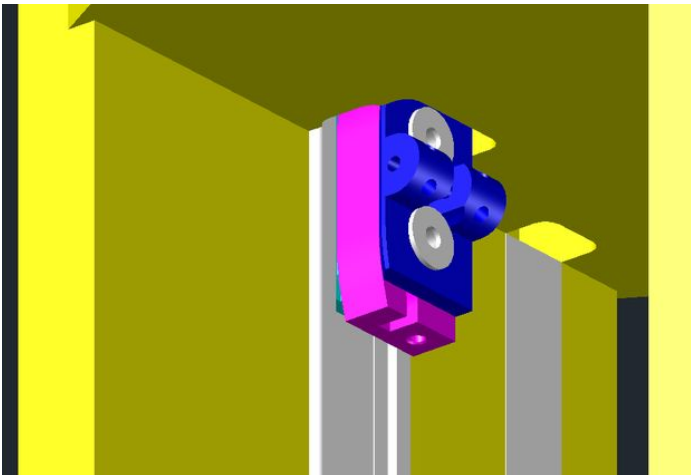
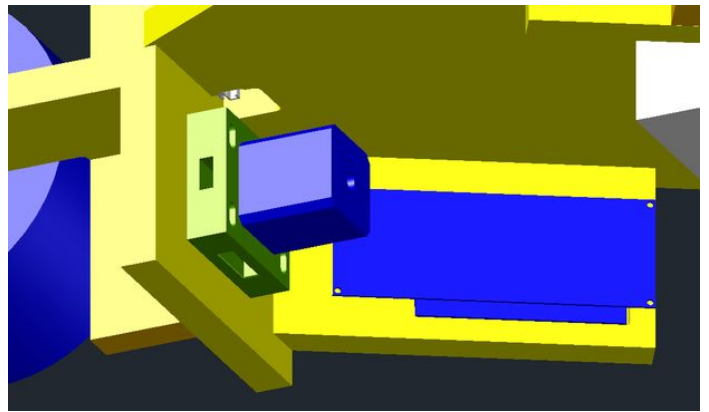
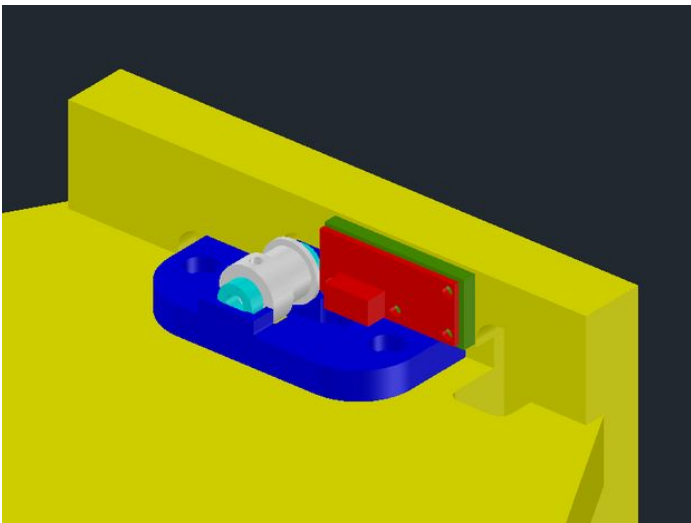
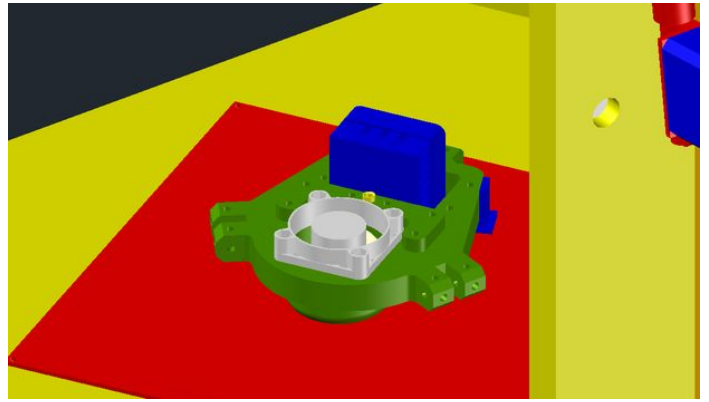
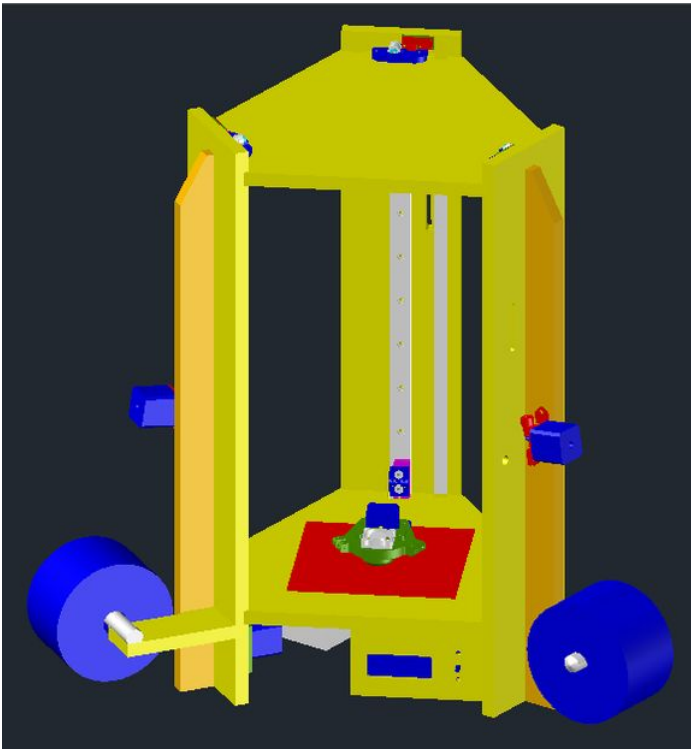



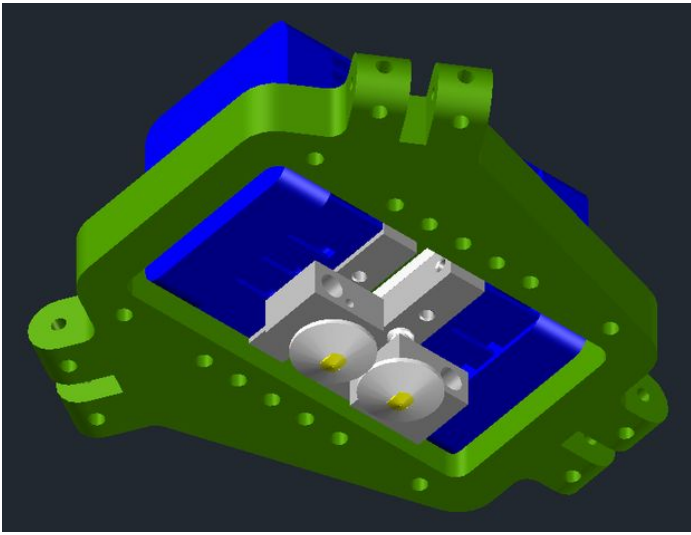

## File Downloads



**DeltaTrix-3D-printer.zip** (2 MB)

[NOTE: When saving, if you see .tmp as the file ext, rename it to 'DeltaTrix-3D-printer.zip']



**DeltaTrix-3D-printer\_IGES.rar** (1 MB)

[NOTE: When saving, if you see .tmp as the file ext, rename it to 'DeltaTrix-3D-printer\_IGES.rar']



**DeltaTrix-3D-printer\_SAT.rar** (1 MB)

[NOTE: When saving, if you see .tmp as the file ext, rename it to 'DeltaTrix-3D-printer\_SAT.rar']

### Step 4: On the cutting edge: panels

I started off with plywood blanks, cut to size in my local DIY shop. I used my CNC machine to do all the cutting and drilling: <http://www.instructables.com/id/CNC-machine-for-shaping-large-pieces-of-polystyren/>

My large CNC machine was only meant to shape large pieces of polystyrene in 3D. As long as it takes cuts in slices, in one direction only, it is very good at it's intended purpose. As soon as it is meant to be cutting slots into wooded panels, it is a little less impressive. Still, I used the machine for cutting the panels for the DeltaTrix 3D printer. I started off by making up a bed. See pics for the details. I then machined the parts by using G-code as if the machine would be working perfectly. I then machined all the pieced I needed using this assumption. As the machine has a lot of deflection, I then measured all the pieces for the deviation and adjusted the G-code to compensate. After all this I machined new pieces, using the adjusted G-code.

Sweet! Now all te pieces are to size!!!

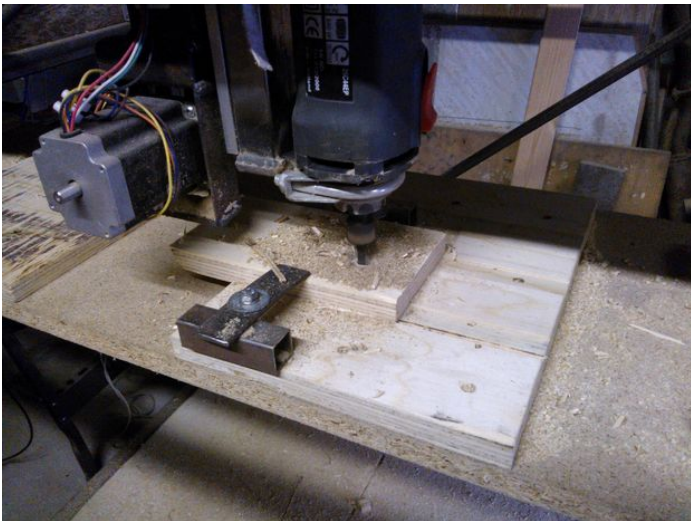









### Step 5: With a little help: plastic bits

In terms of getting hold of the plastic bits, it is a case of catch 22. You need access to a 3D printer in order to make the plastic bits for a 3D printer. My initial bits actually came from Instructables.

Some time ago I did win a 6x6x6 inch 3D print as a result of entering the 'make it real' competition. Initially I intended to use the print for a CNC machine: <http://www.instructables.com/id/6x6x6-3D-print-Delta-CNC/> I entered the design for the machine in a contest, hoping to win a Makerbot 3D printer. As this did not work, I then changed my plan and used part of the print for the creation of the plastic bits for my own 3D printer design. The green bits in the pictures are the bits from Instructables (many thanks by the way - great job!!!). The white bits for the top pulleys, required for improving the drive belt design, have been made by Austin on his Ultimaker. I am very grateful to him for this as the parts look absolutely brilliant. The quality of the parts are so great that I regard the Ultimaker printers as the benchmark for Open Source 3D printing. The blue bits are the first set of parts created on my own DeltaTrix, in order to provide the parts for a new DeltaTrix 3D printer. They will become part of the printer for Kirk, who I thank for having sufficient faith in the design to get involved at a very early stage. Being the first parts I printed, the blue bits were a bit rough and needed a bit of cleaning up. Over the last few weeks I have constantly made improvements and the print quality is now a lot better!

The current design is meant for use in conjunction with T2.5 timing belt. In order to get the bits working with GT2 timing belt, a pair of M5 washers might need to be added to the top pulley assembly as certain GT2 pulleys (eg. those from Reprapdiscount) are a bit small in size. Also, the bits for clamping the belts need some adjustment as GT2 belts are thinner than T2.5 belts. In the near future I will address this and publish the modified SAT and STL files in this section. For now, if you are impatient, take the 3D DWG from an earlier step and do it yourself. The STL files which are currently attached to this step, were originally designed to work with T2.5 belts and a single <http://www.instructables.com/id/DeltaTrix-3D-Printer/>

extruder with fan cooling.

Note: see a further step for a link to the extruder parts.

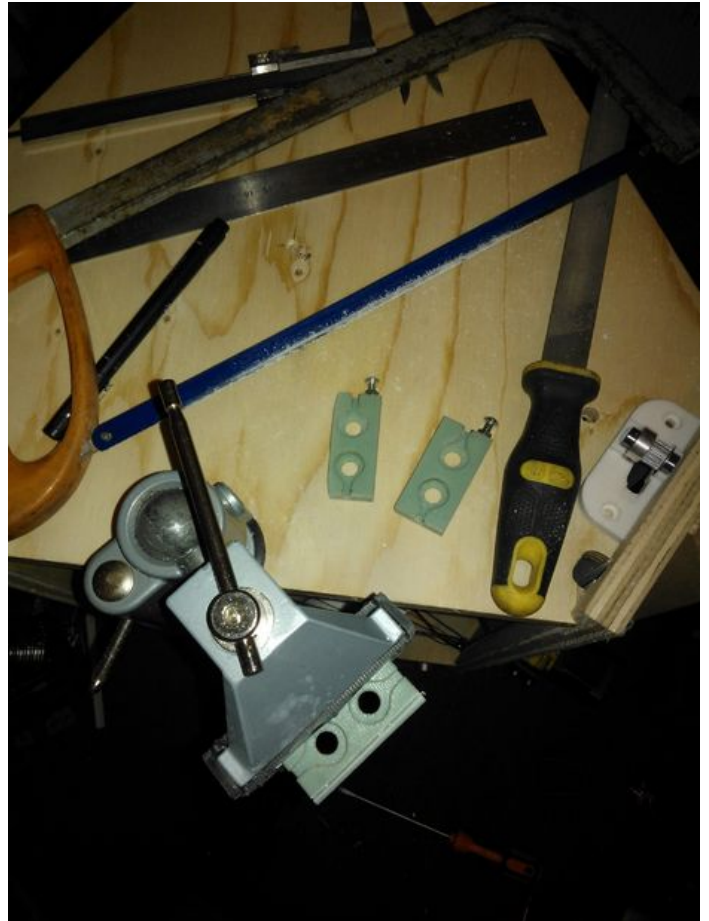
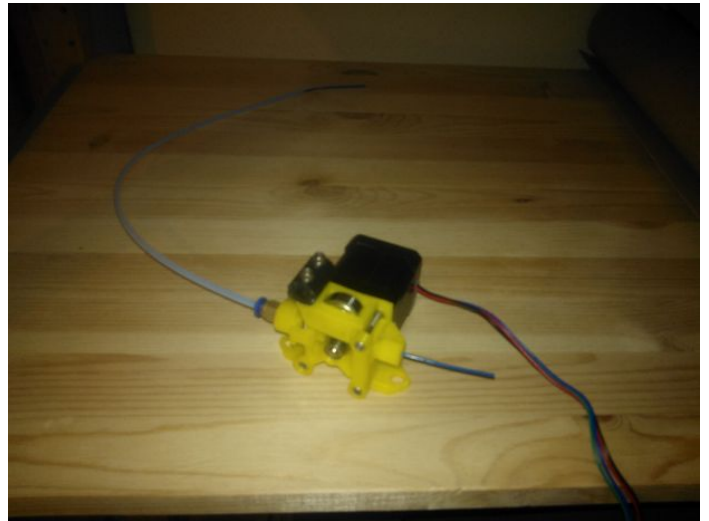



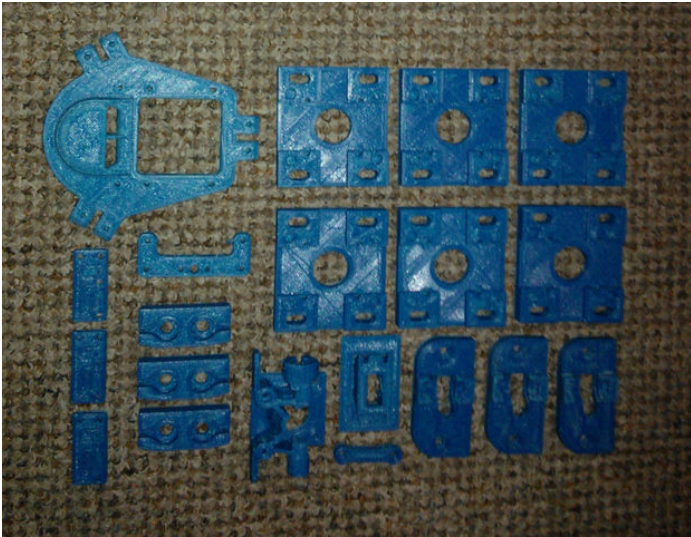
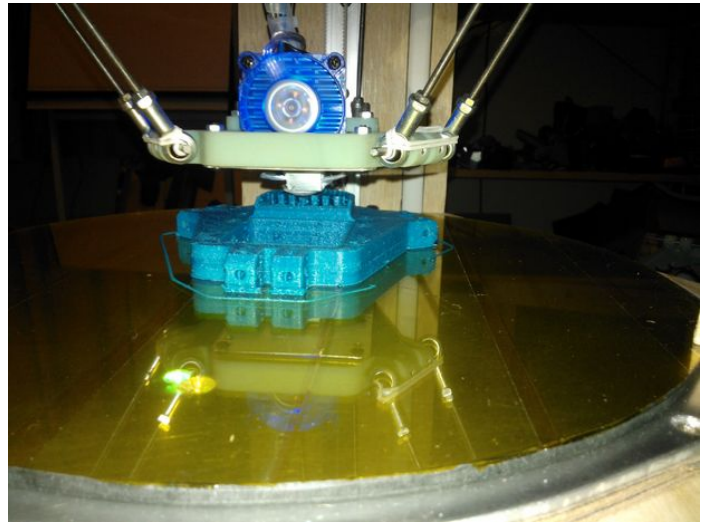

## File Downloads



**motor base.stl** (205 KB)

[NOTE: When saving, if you see .tmp as the file ext, rename it to 'motor base.stl']



**nozzle bracket - cooling duct version.stl** (71 KB)

[NOTE: When saving, if you see .tmp as the file ext, rename it to 'nozzle bracket - cooling duct version.stl']



**nozzle carriage with cooling duct 110813.stl** (399 KB)

[NOTE: When saving, if you see .tmp as the file ext, rename it to 'nozzle carriage with cooling duct 110813.stl']



**pulley bracket for T2 and a half.stl** (100 KB)

[NOTE: When saving, if you see .tmp as the file ext, rename it to 'pulley bracket for T2 and a half.stl']



**slide carriage part1 for T2 and a half.stl** (104 KB)

[NOTE: When saving, if you see .tmp as the file ext, rename it to 'slide carriage part1 for T2 and a half.stl']



**slide carriage part2.stl** (164 KB)

[NOTE: When saving, if you see .tmp as the file ext, rename it to 'slide carriage part2.stl']

## Step 6: Buy, buy, buy: hardware & electronics

The parts to be bought are listed in the attached spreadsheet. Most can be obtained via Ebay... There are probably a few items missing, but nothing major. I will try to update in the future.

# BOM

## File Downloads



DeltaTric BOM 211013.xls (15 KB)

[NOTE: When saving, if you see .tmp as the file ext, rename it to 'DeltaTric BOM 211013.xls']

## Step 7: Free, free, free: software

Initially I looked into using delta geometry based on pivot points, but I was hesitant as there was no software readily available when starting the project. Always having liked the iFab by Festo, I decided to go for a linear delta layout when I found out about some German dude publishing the firmware for his delta as Open Source. Thanks Johann, for being a knight in shining armour!

As PC software I use Repetier host. It is available as Open Source as well and it has provisions for the delta layout. There is also Repetier firmware that should work with my hardware, but I have not yet tried this.

I use the Open Source Arduino environment to edit the firmware to my needs.

I grabbed the pictures in this step from the net. They are the property of their respective owners.



## Step 8: Upright assembly

The upright assembly is critical to the correct functioning of the printer. Take really good care not to overtighten the screws. On a 18 Volt drill, acting as a screw driver, I use about a third of the maximum torque setting for the final tightening. Any more and there is the risk of warping the delicate, linear rail.

The pulley for the motor needs to be fitted the right way around and at the exact location as indicated in the 3D model from an earlier step. I thank my son Nick for his expert assistance during this stage!



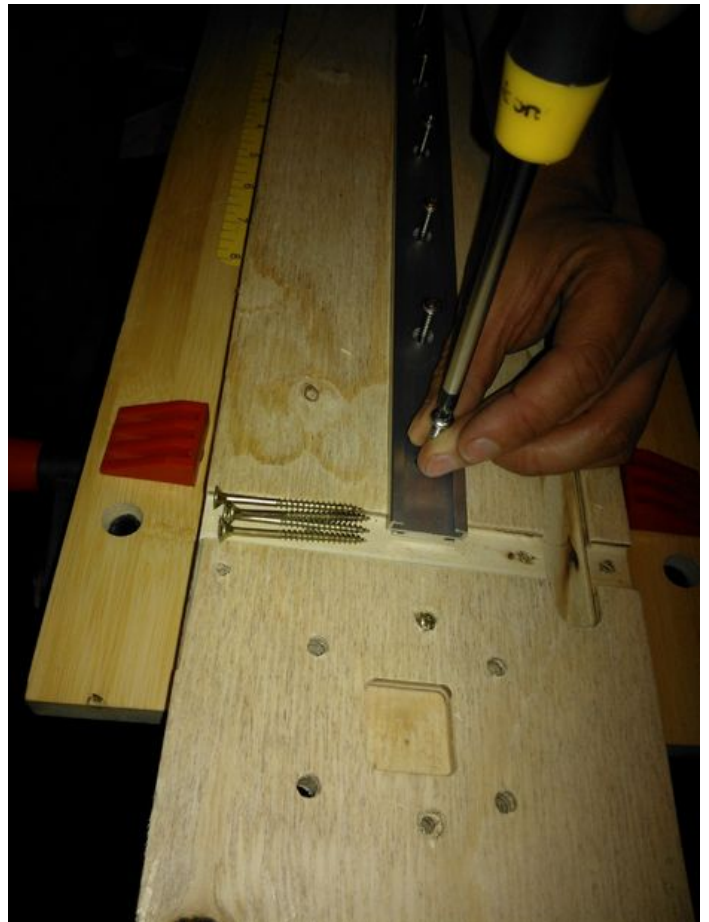



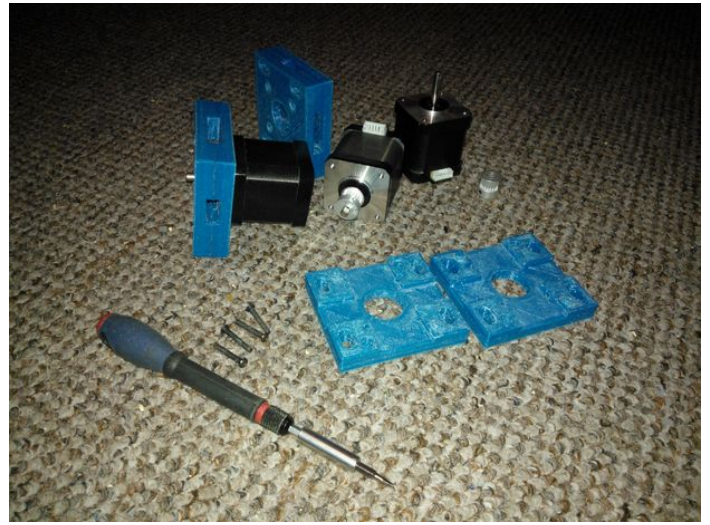

### Step 9: Frame assembly

Connecting the uprights with the top and bottom panels effectively completes the main frame structure. Use self tapping woodscrews in conjunction with screw cups and torque them down evenly. It pays to mark the holes for the heated bed beforehand. If you have not done so before, make sure the carriages slide easily and evenly along the entire rail. If there are any issues with this, it likely to be caused by some of the screws having been over tightened in the previous step. In one of the pictures you can see my son Nick coming to the rescue, by giving the slides a good test!

It is a good idea to connect the spool holder at this stage, as it will be difficult to do this when the electronics are in place. You have a free choice for placing this as all uprights are identical. I did put mine in a way so I can have good access to the extruder from the front of the machine.









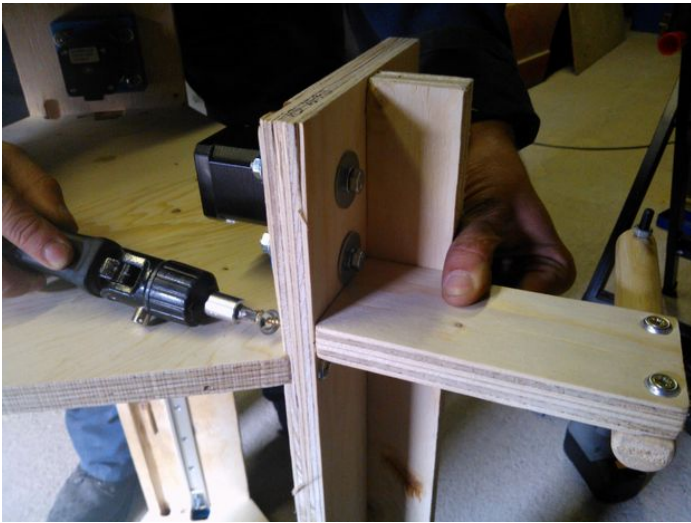

### Step 10: Belt drive

Some M4 threads need to be cut in this step. See pictures as they should be self explanatory. What the pictures do not show is the fitment of some M6 thread inserts and screws in the lower base panel, which can be used for tensioning the belt. When fitting the belt, make sure they are the right length to allow for adequate tension. You have to judge this for yourself, just be careful not to overtighten the belts as this would stretch them. Try to 'twang' them like a guitar string and make sure they are all similar in tension by comparing the sound.

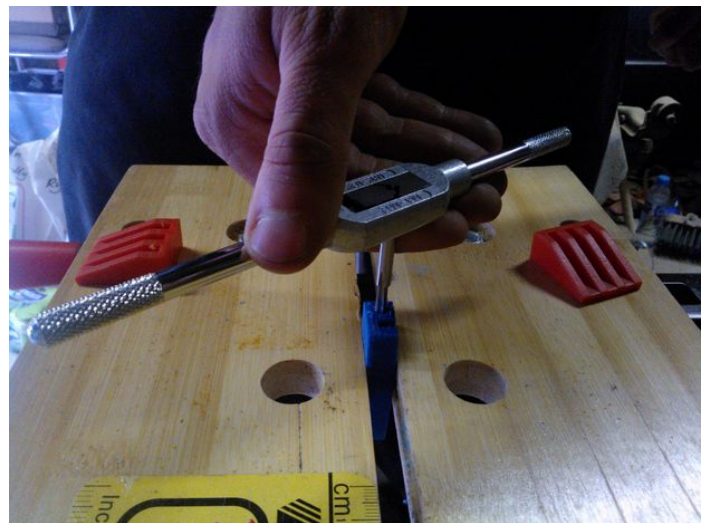

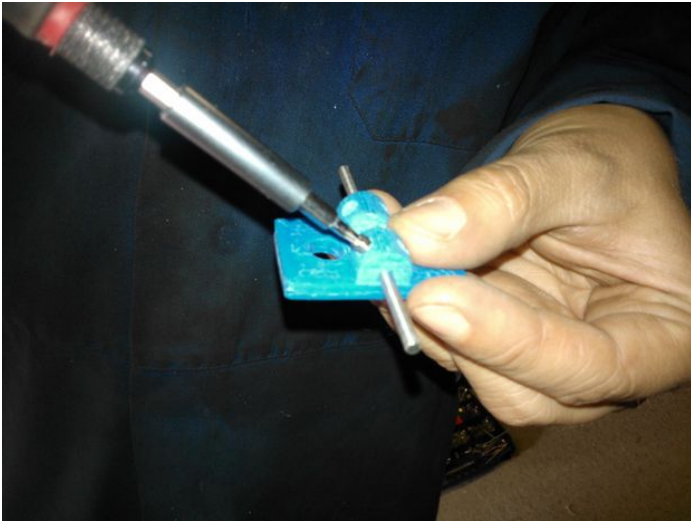
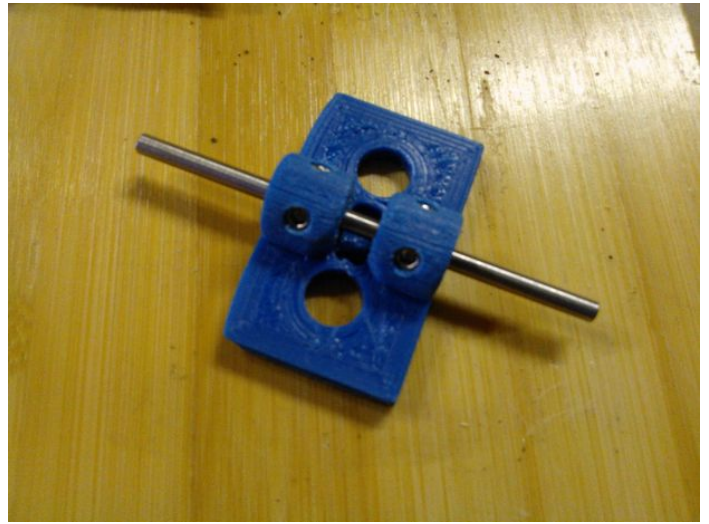



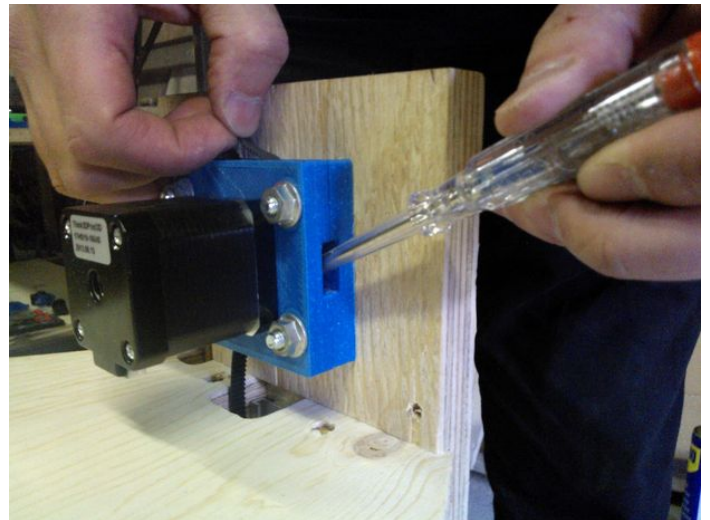
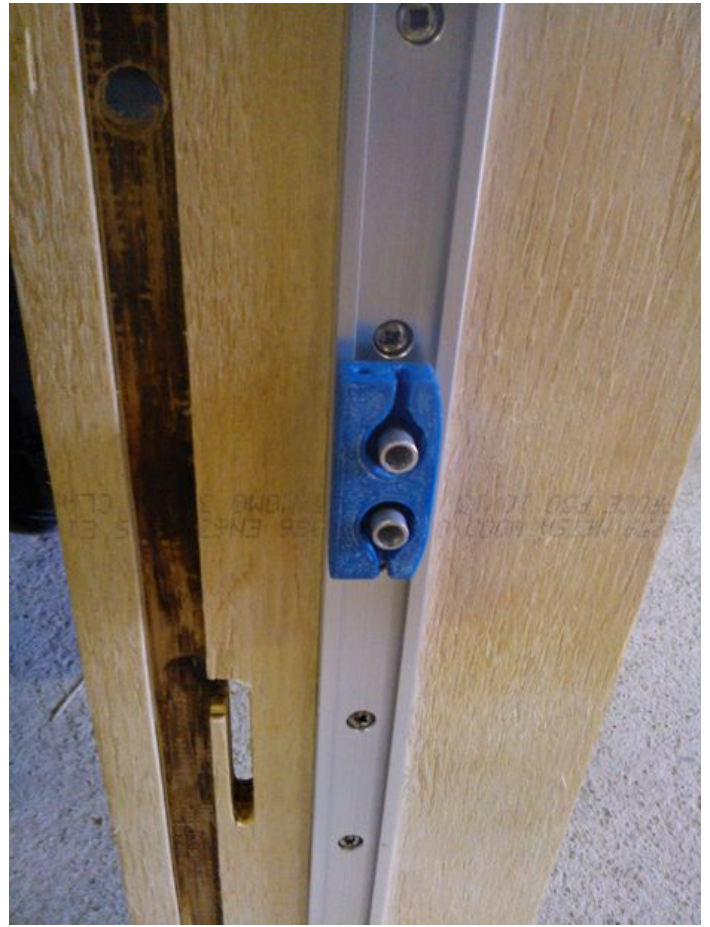



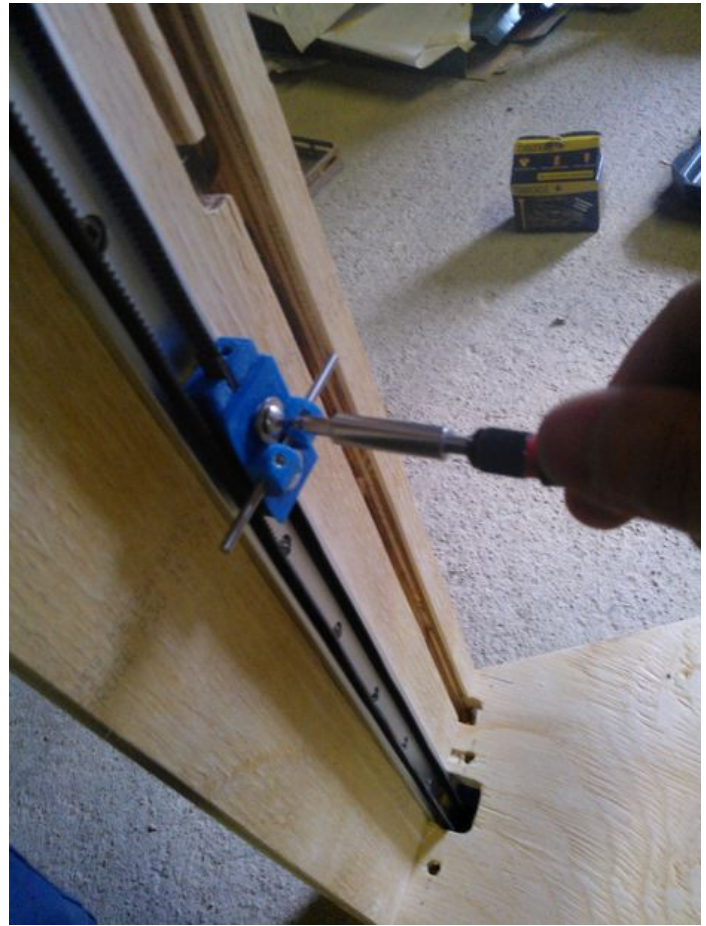

### Step 11: Extruder

Initially I did get my Airripper's V3 extruder bits from Ebay. It was the version which uses a standard pneumatic fitting for connecting the bowden tube. Although it did its job ok at the beginning, very quickly little cracks started to appear in the PLA plastic. After fixing my extruder using glue, I managed to print spare parts in ABS and use these instead. I have not had any problems with it since.

Link to the extruder files: <http://www.thingiverse.com/thing:126778> Thanks Airripper, for your simple, yet effective extruder design!

Over time I have used PLA and ABS from several suppliers and a large variation in quality was evident. Some of the cheaper material did have a lot of dust, resulting in frequent nozzle blockages. I resolved this by wrapping a sponge around the filament, held in place with a ty-rap. This effectively eliminated blockages instantly, but it did not look very good. See the last picture for my current dust cleaner, which I found on Thingiverse: <http://www.thingiverse.com/thing:210616> Many thanks thewhitegoth, for a solution which is effective AND good looking!

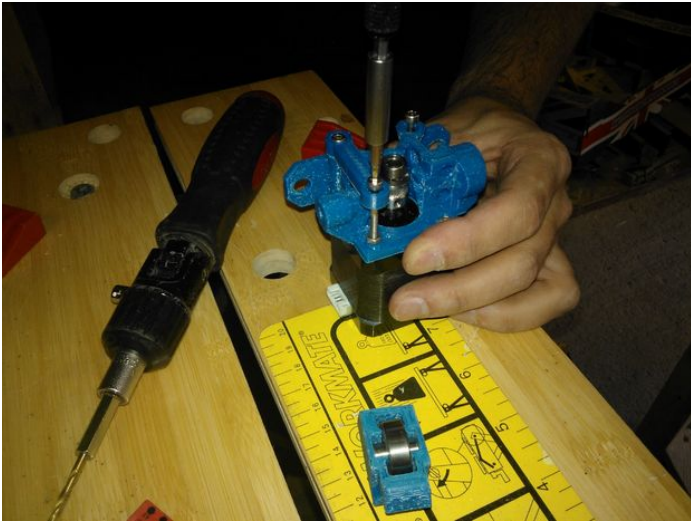
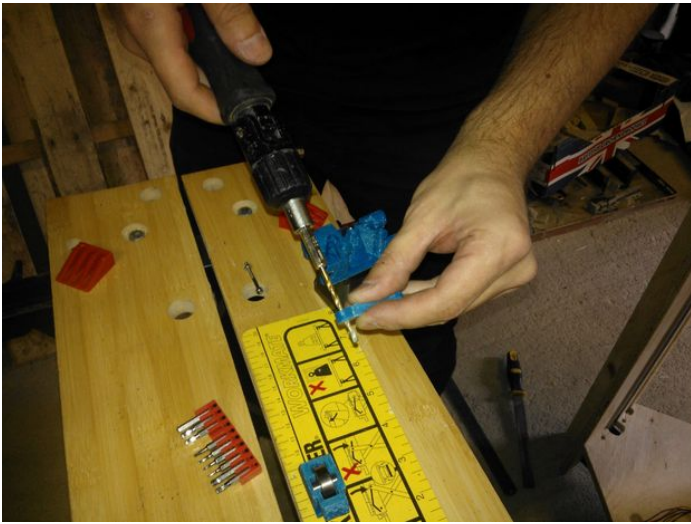



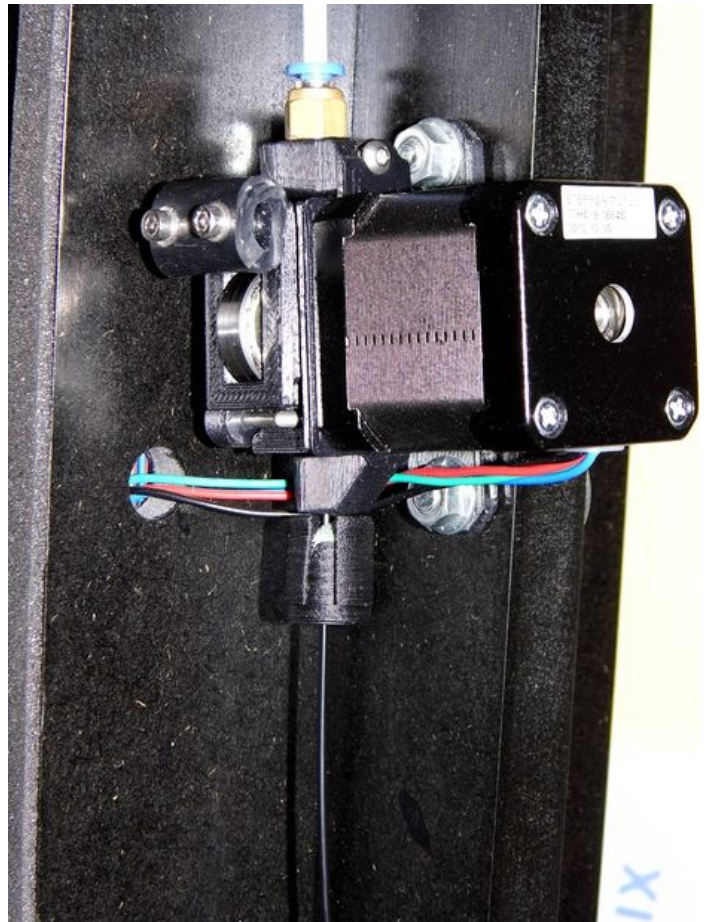
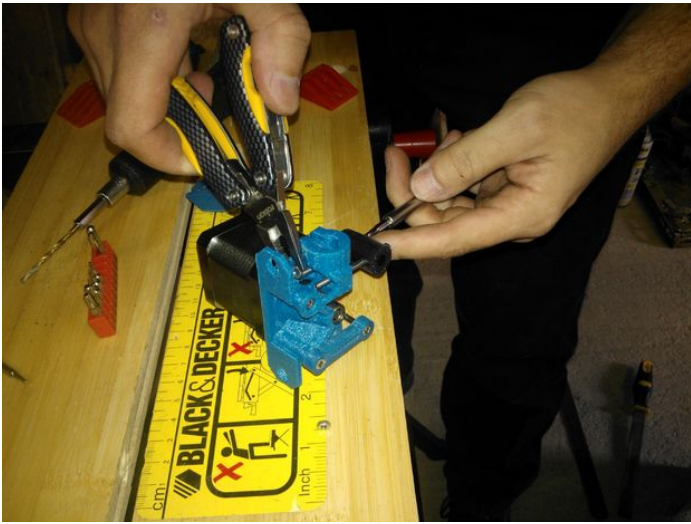

### Step 12: Connection rods

Although the use of carbon fibre rods is very popular with Delta robots, I like the simplicity of steel, threaded rods. Get hold of some remote-control-car-rod-ends and go the carbon rod route or do what I did and stick with steel. In this case, cut the rods at 250mm lengths and set the distance from eye to eye to be 280mm. See the picture for a method for ensuring they are all the same length. Also make sure the locknut is done up tight.



### Step 13: Print head assembly

I use a hot end, made by the good peoples at RepRapPro. It is not just because they are based a short distance from where I live, but mainly because it such a nice unit. It features forced cooling on the cool end, is very compact and is designed for a bowden tube. Thanks Adrian & co., for designing and providing such a nice unit!

Please, refer to the original RepRapPro assembly instructions as they are very good: [http://www.reprappro.com/documentation/RepRapPro\\_Tricolour\\_hot\\_end\\_assembly](http://www.reprappro.com/documentation/RepRapPro_Tricolour_hot_end_assembly)

I use the pre-crimped wires from my electronics kit to connect to the thermistor. This worked pretty well, but it did need a tiny bit of tightening with some small pliers in order to get the right fit. The optical sensor is for future use. I am hoping to use it for some sort of auto leveling (should eventually work with Johann's code for this), although I have been coping pretty well with manual leveling so far.

In case you would like to use another hot end, feel free do so. Please, pass on the design file or link to the end effector for holding your choice of hot end, and I will include it here.





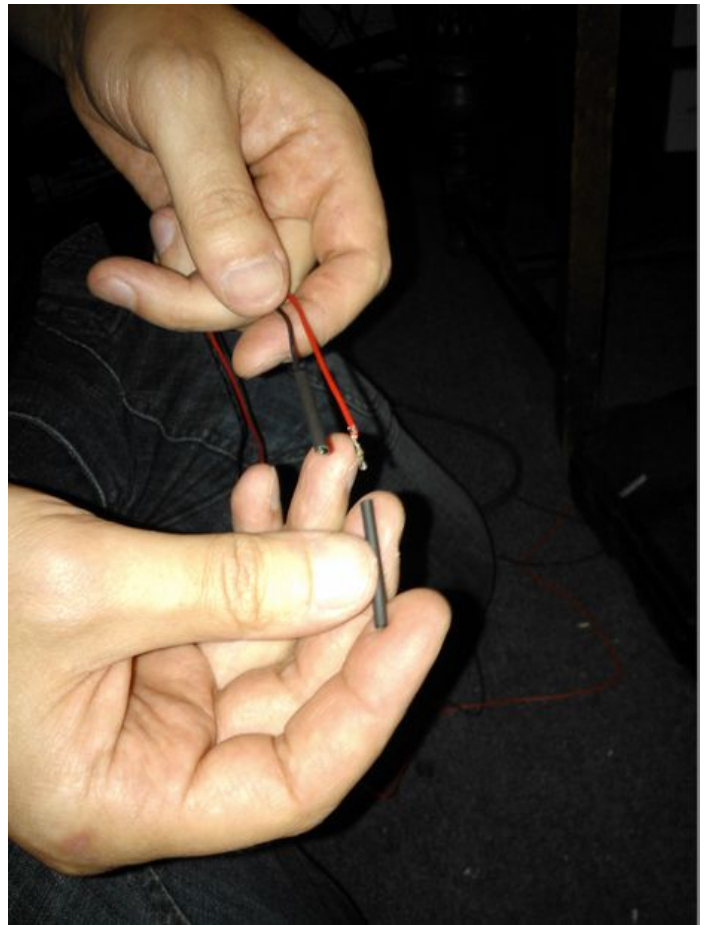
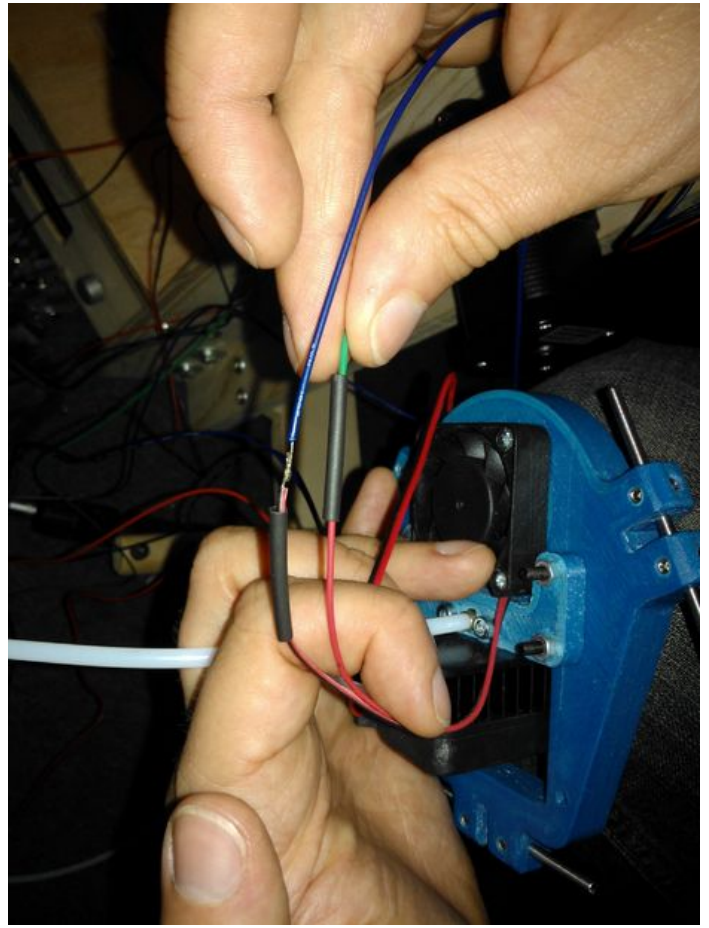
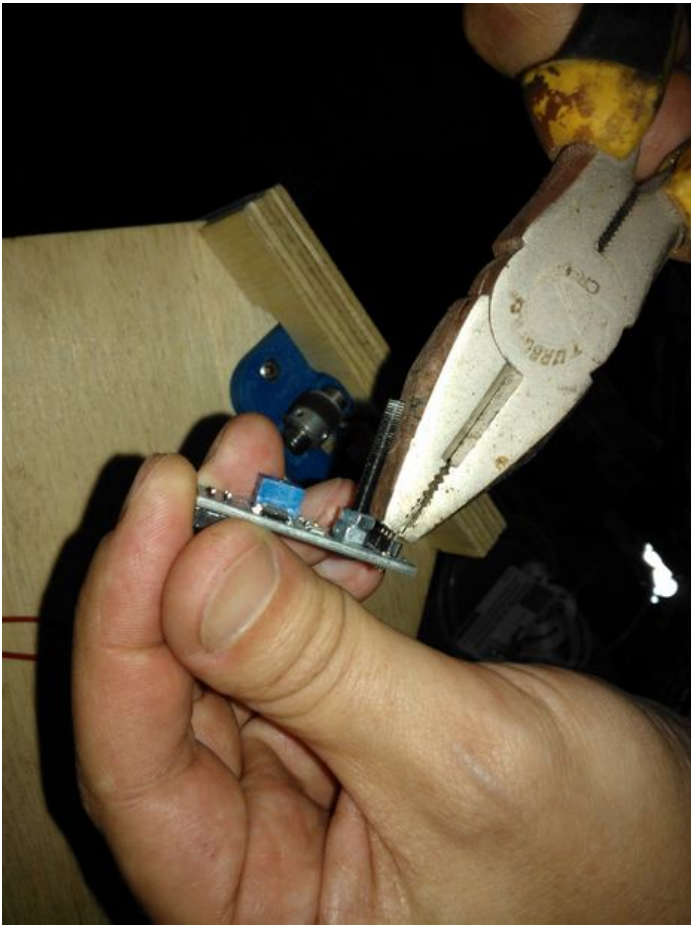



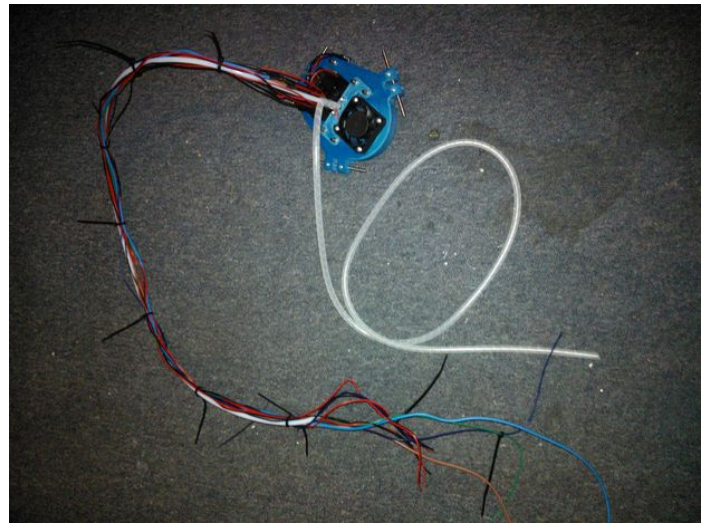

### Step 14: Heated bed

I only use three screws to fit the heated bed, as three points on a plane are sufficient to locate it. Having four screws would over-define the plane and potentially warp it. By the time a 3mm thick glass square (200x200mm) is attached to the MK2 PCB it should be fine (Prusa, thanks for the design of the initial PCB and thanks to others for improvements). Be aware, there are many different 'MK2' boards around, not every one as good as the other. Not shown here, but look at pictures in further steps, I use Supacclip 60 clips to attach the glass to the PCB. The clips look great and allow minium clearance to the print head.



### Step 15: Fitting the electronics

This is straightforward, just screw everything to the bottom of the base panel! Note how the LCD panel is held on with angled brackets. One of the brackets needs to be tweaked, so the angle opens up from 90 degrees to the required 120 degrees. Also, make sure the panel does not block the cable opening in the upright - mark up if necessary and trim as required. Stick double sided tape to the top of the power supply and tie it down, using angle brackets and tie rips. The tape will stop the unit from moving sideways. Don't forget to fit guards on the fan, as it will be too easy for wires to get trapped otherwise!

The power supply does have a built in on/off switch, which saves having to fit an external switch. The RAMPS electronics have been placed with the reset button being accessible from the side of the machine. Access to the USB connector is a bit tricky, just keep a bit of clearance when wiring up in the next step. I only use USB for doing the calibration. At the moment I use a SD memory card for doing actual prints. In the future I want to try and use a Raspberry Pi in order to provide a Wireless connection. I already screwed a Pi to the base of my own Trix, proving there is sufficient room to fit it in.

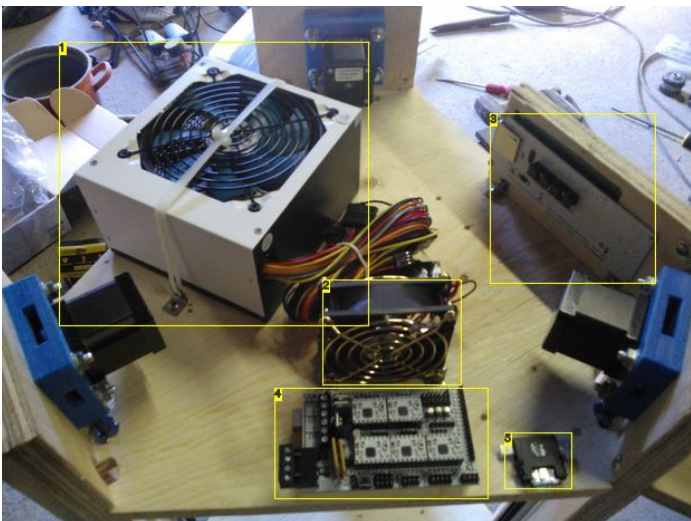



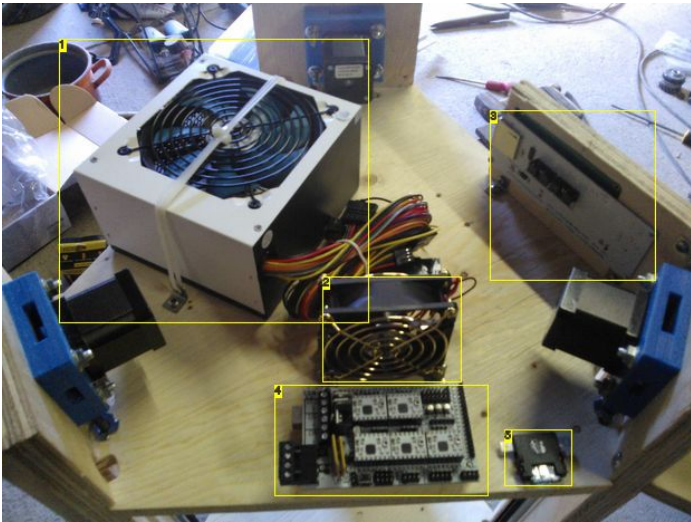

#### Image Notes

1. ATX PC power supply, make sure yours is powerful enough (over 16 amps on 12V line). Use double sided tape to stop it moving whilst being tied down with tie rips to angle brackets.
2. 80x80mm PC fan. Will connect straight to your PC power supply and provides a cooling flow over your RAMPS electronics.
3. LCD display. Screw in with self tapping screws. Notice the access to the SD card slot.
4. RAMPS v1.4 electronics. This is the heart of the 3D printer. Use different electronics if you wish; as long as it can attach to a piece of plywood I am sure you can make it work!
5. Automotive blade fuse holder, with a 15A fuse fitted. The standard heated bed fuse on the RAMPS board can be troublesome. Use this instead. Wiring required!!!

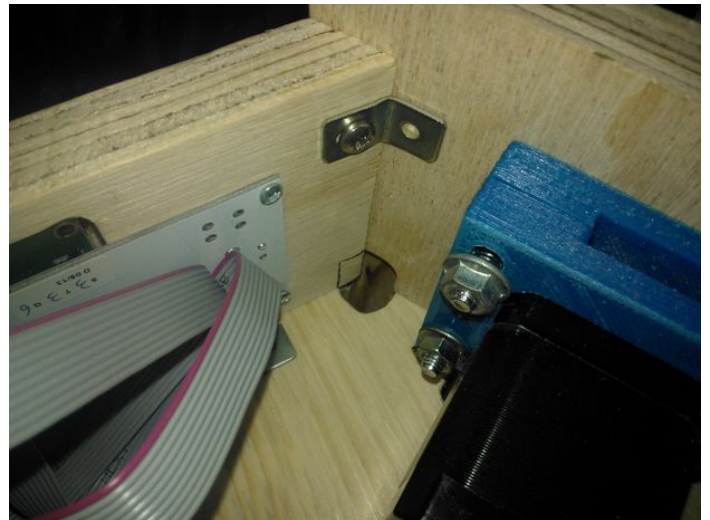



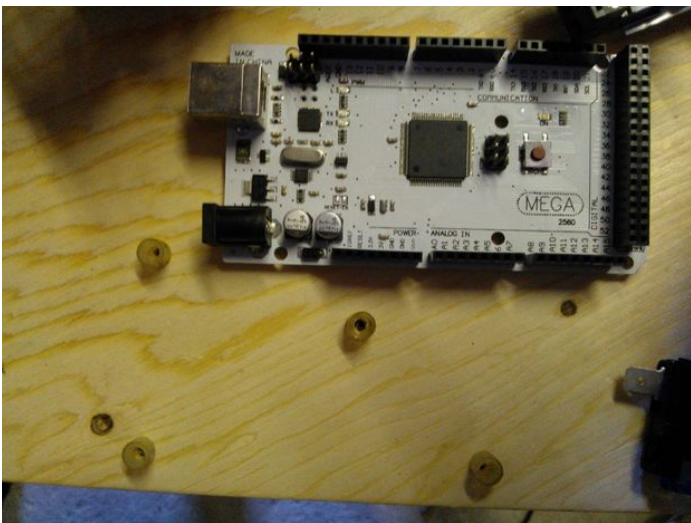
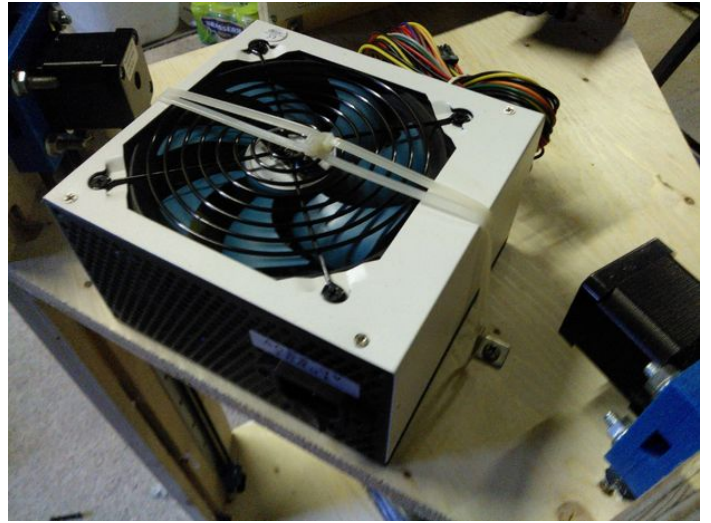
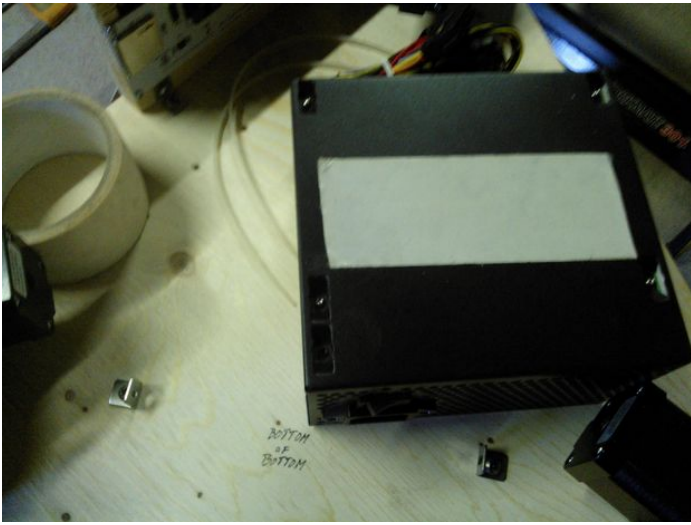



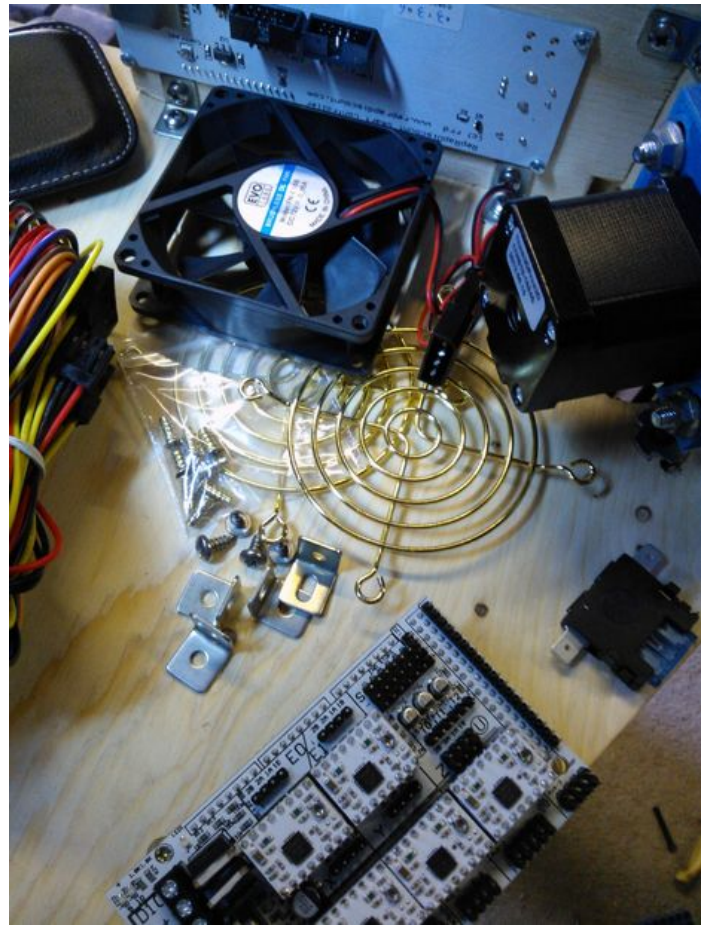
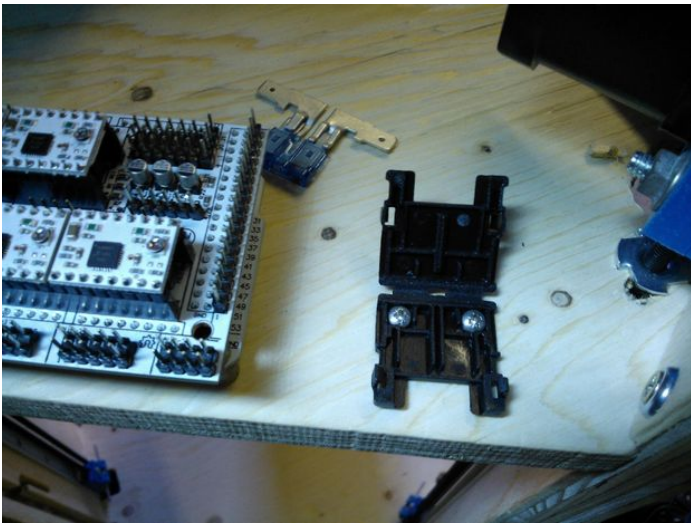
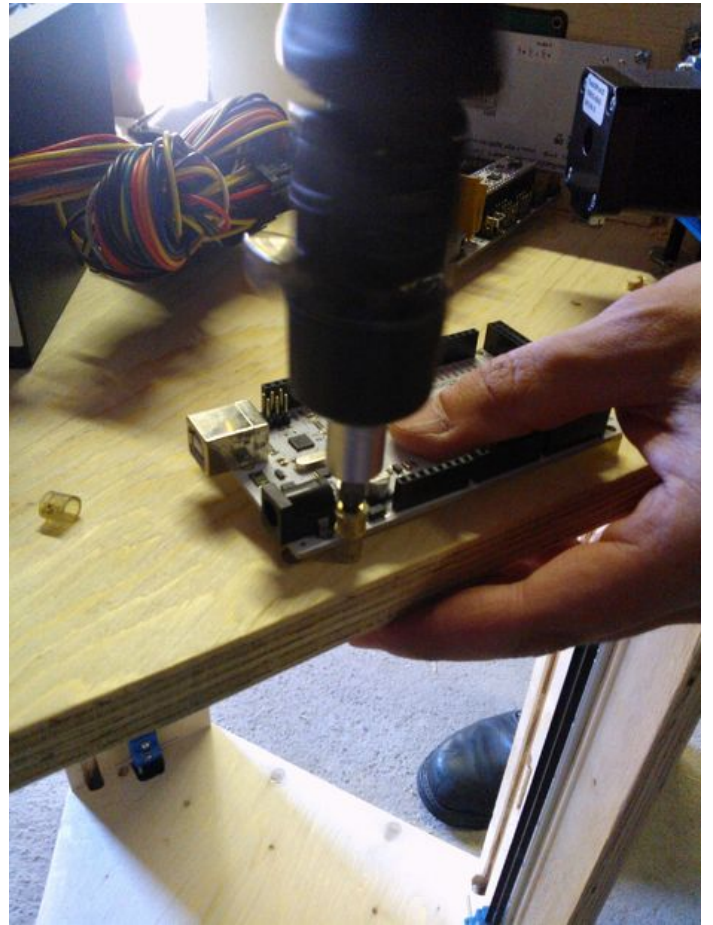
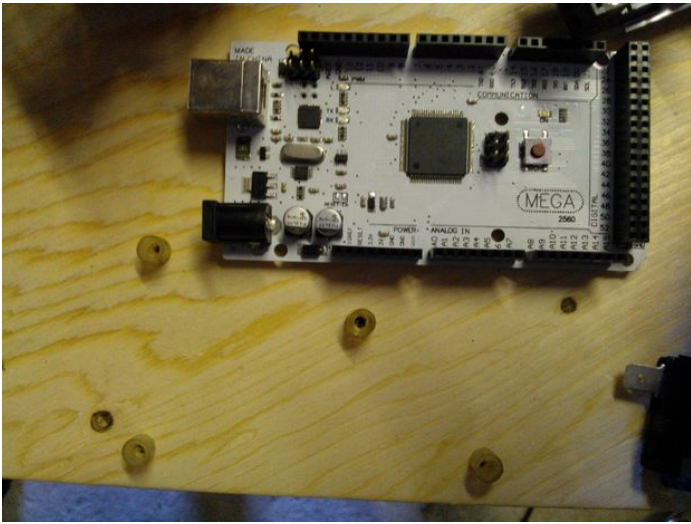



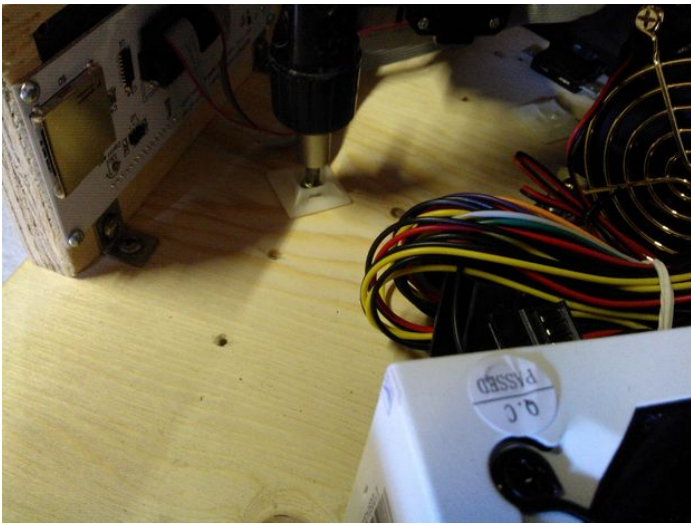
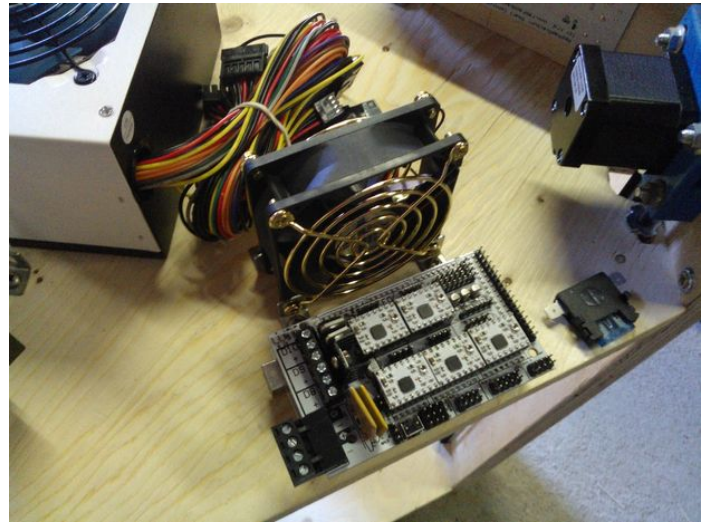
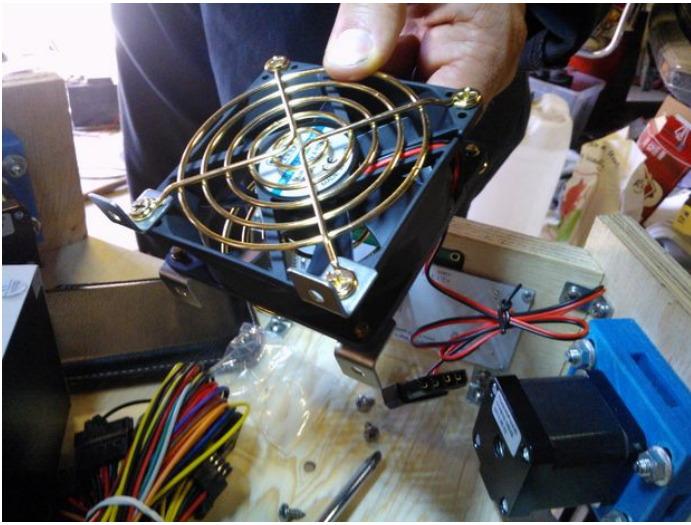

### Step 16: Wiring

If you decide to use RAMPS v1.4 electronics, the wiring is largely according to the standard schematic in the 'wiring' section of these instructions: [http://reprap.org/wiki/RAMPS\\_1.4](http://reprap.org/wiki/RAMPS_1.4)

Some deviations from the standard have been done. To begin with, I wired in a 15A automotive fuse. This will allow for a more reliable operation of the heated bed, as the standard fuse (F2) on the RAMPS board can be troublesome in operation. A PC power supply unit (or PSU) can be used with minor adaptations. I used a power supply featuring a on/off switch. When shortening two wires as shown in the photos, the power can be switched on using the switch. I fitted a 4R7 7W resistor to the 5V line in order to give this part of the PSU a minimal load. I actually cut the original connectors from the PSU, which means I am voiding the warranty. Make sure your unit works ok before doing this as well! I could have shortened the motor leads and I also could have trimmed some of the other wires. I kept it simple and slightly messy, by just looping them and tying everything down with tie rips.

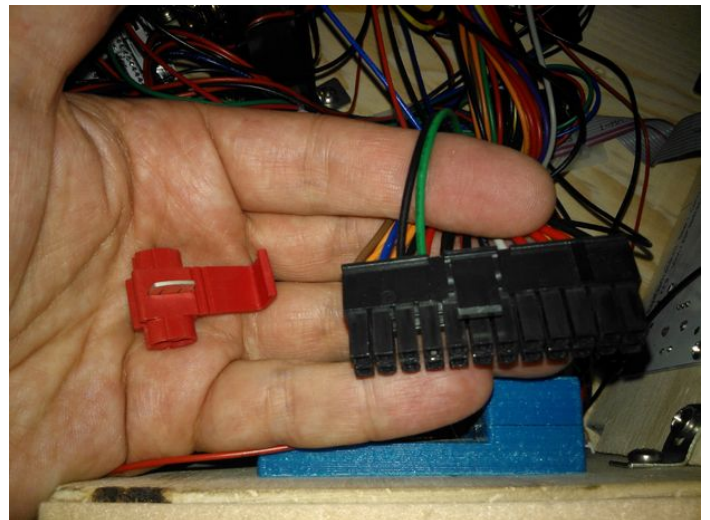
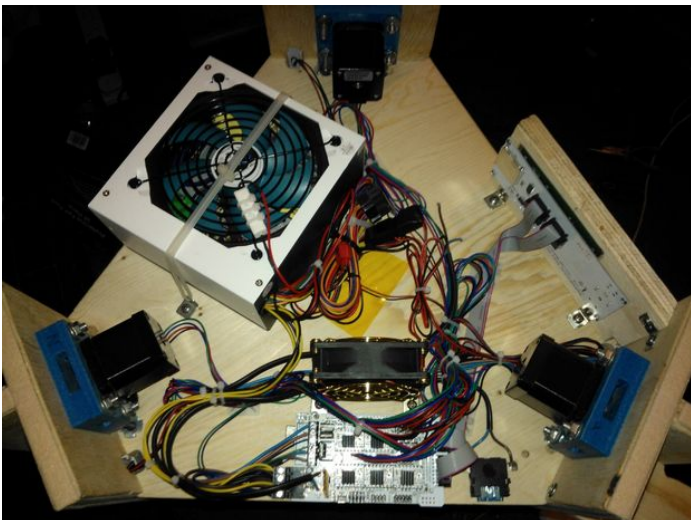



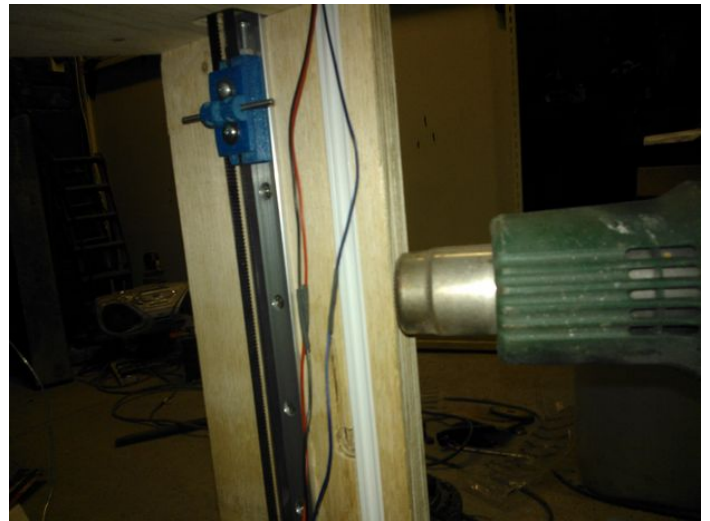

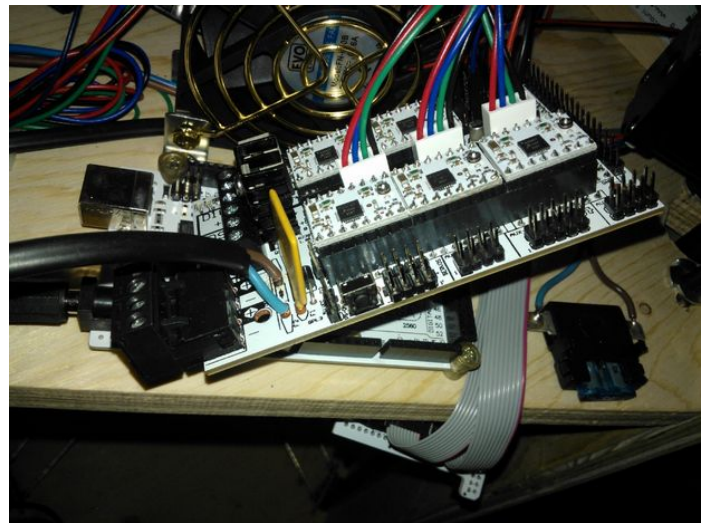
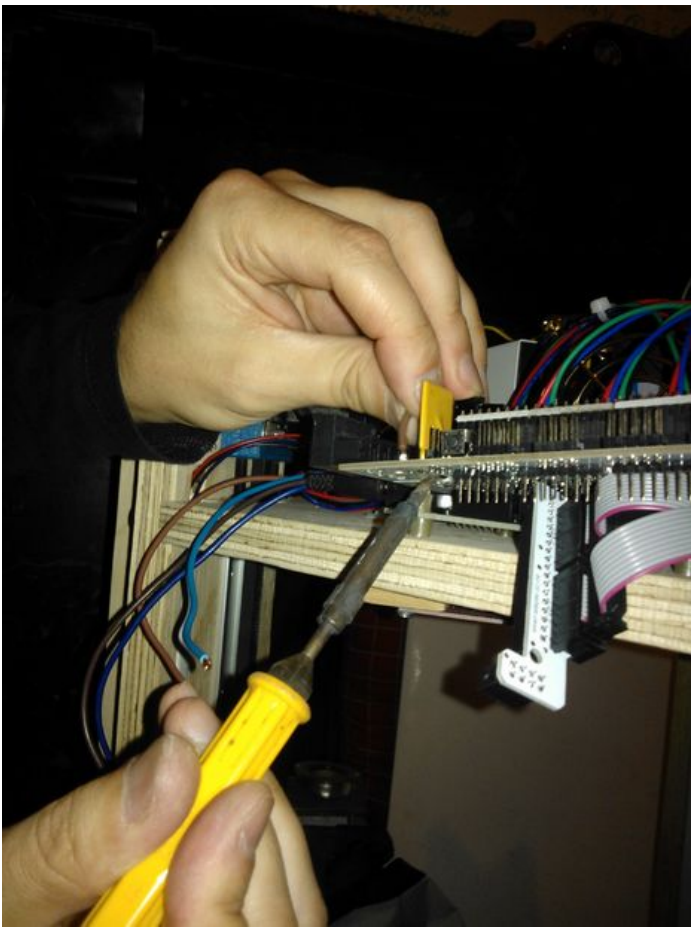
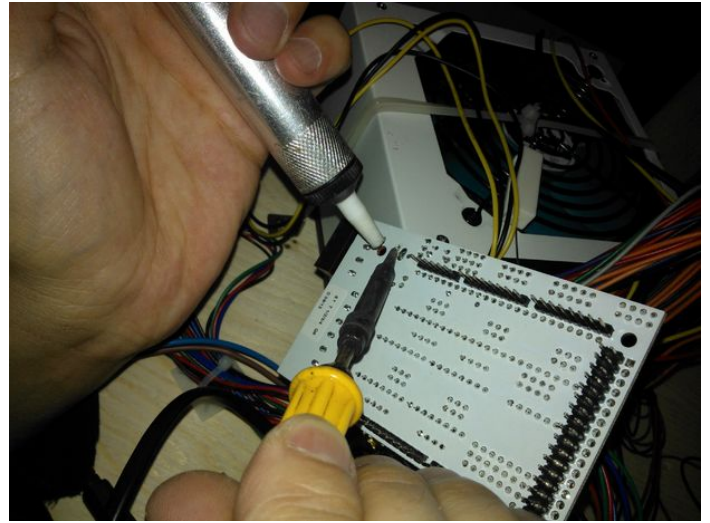
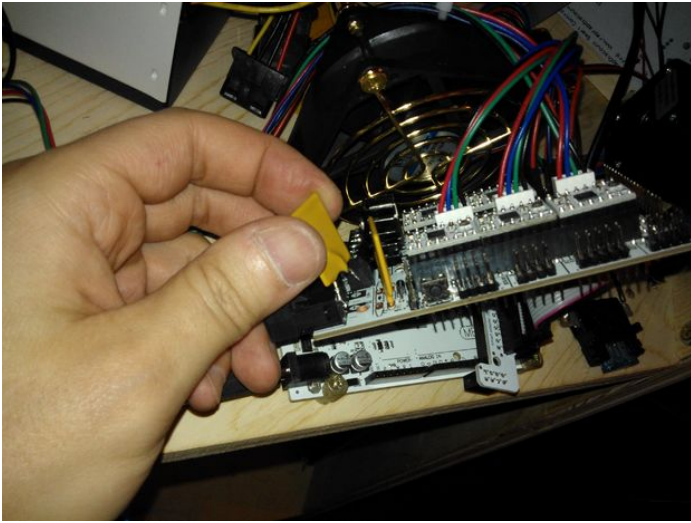



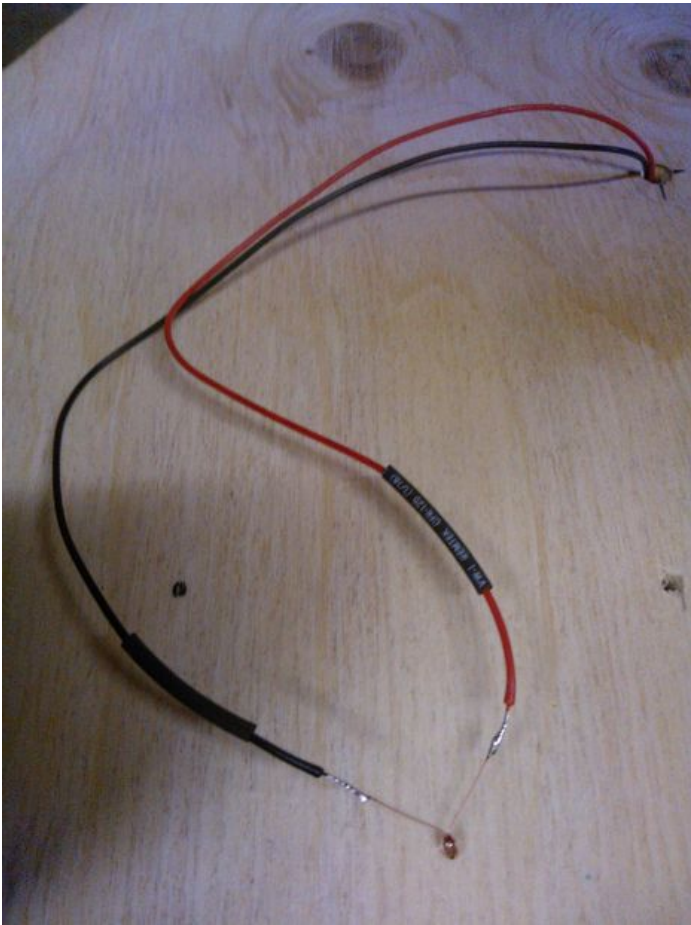

### Step 17: Installing software & uploading firmware

Go to <http://arduino.cc/en/Main/Software> for the software, needed to upload the firmware. I still have to clean up the code before uploading it here, but I am sure I will have it done before you finish building your own printer... ;-)

On your PC you will also need to install some software, for which I recommend Repetier: <http://www.repetier.com/download/>

I have only used the Windows version of the software, so I cannot guarantee anything related to the MAC version. Wait a minute, guarantee? Hold on, all this info is for free anyway. As such, there isn't any guarantee to begin with!

The picture comes from <http://www.neatorama.com/2012/07/04/evolution-of-windows-logo/#!I2M2O> The picture and the logos are the property of their respective owners.

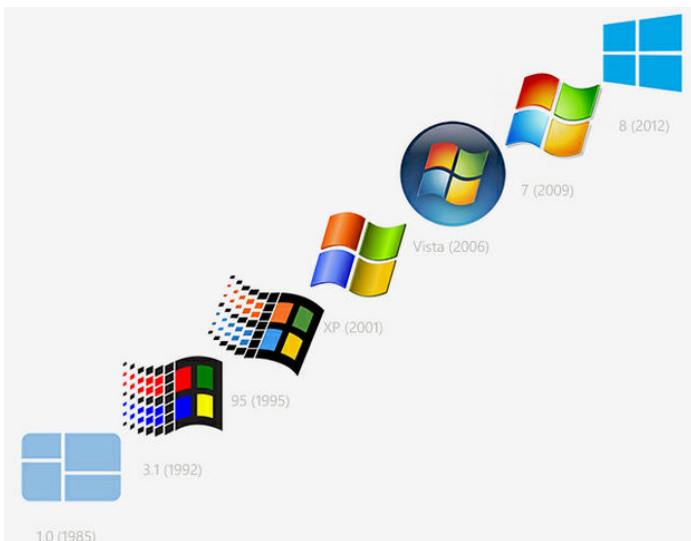

### Step 18: Calibration

In terms of the mechanical layout, it should be fairly simple. As long as all the panels have been machined accurately and the rails have been screwed down properly, the geometry of the machine should line up ok. You can check with a square to be sure.

In the slide carriage assemblies you need to put some M4x20 button head screws in conjunction with some lock nuts. Adjust these to line up with the print bed. You will also need to tweak the firmware to take account for the actual DELTA\_SMOOTH\_ROD\_OFFSET. Finally, you will need to set the actual height to the print bed. All this can be done fairly easily, provided you have an end effector with a DTI clock and a little bit of patience in following the instructions. The design for a purpose made DTI clock head assembly, and detailed calibration instructions will follow soon.

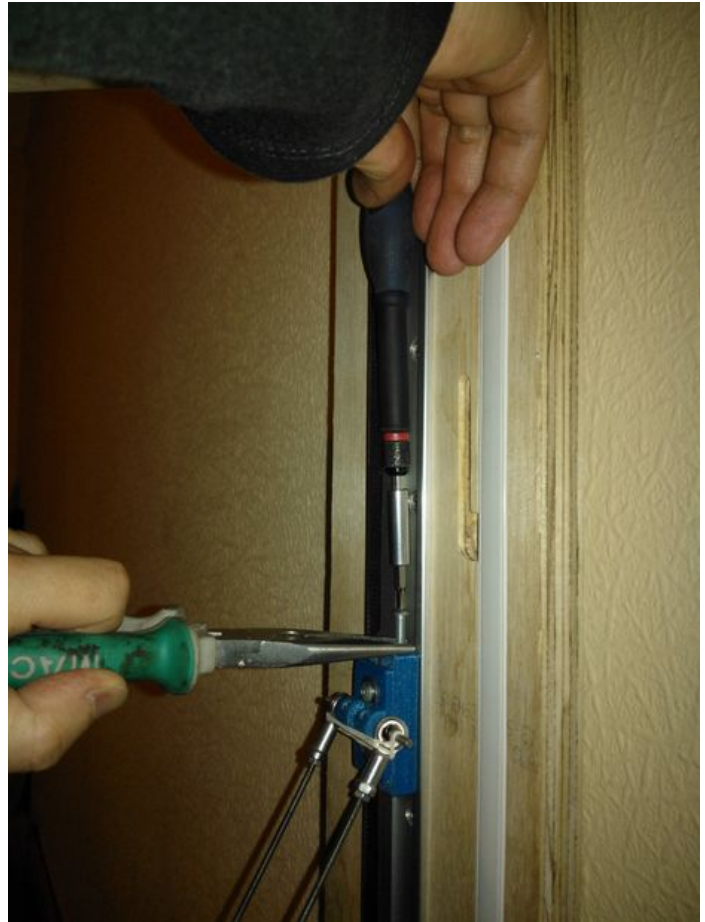
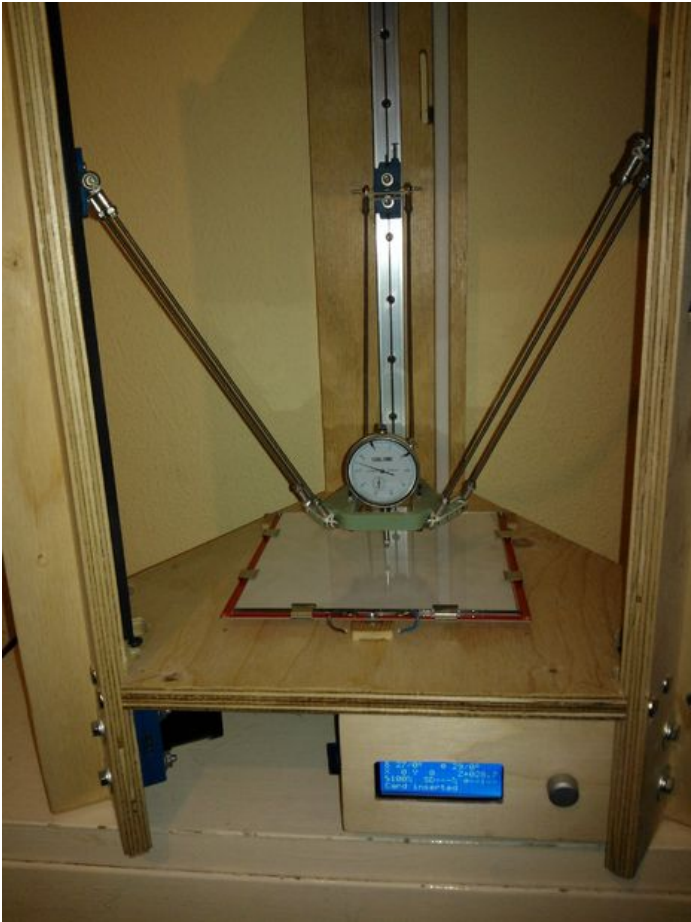

### Step 19: First print

The attached photo shows the first print from the second DeltaTrix 3D printer. Try to aim for something small as the first print, just as shown...





## Step 20: Conclusions

I really like my DeltaTrix 3D printer. I think it is awesome! Since building it I have been able to print improvements to my own printer and I have been able to print some designs I never would have seen become reality otherwise.

If sufficient peoples would like to have a DeltaTrix 3D printer of their own, but do not have the means to make all the bits themselves, I will potentially start a Kickstarter campaign and use it to offer kits for self assembly. In the long term I am also prepared to supply fully built units, but not just yet...

Update (26-12-'13): A [Kickstarter](#) project for the DeltaTrix 3D Printer is now live!

The name of my printer is not DeltaTrix without a reason. Everyone can see it is a Delta, but in terms of the trix part, there are loads of tricks it has up it's sleeve:

- All uprights are identical. An extruder and filament coil can be fitted to all three of them. Although the RAMPS electronics can only provide for two print heads as a default, three extruders can be fitted from a mechanical point of view.
- On top of the printer there is some free space for something... I already tried fitting a turn table in conjunction with an Xbox Kinect sensor, acting as a 3D scanner. So far I am not entirely happy with the end result as I think the Kinect is more suiteable for people-sized objects. Larger objects could be done with a normal 2D (phone) camera in conjunction with 123D Catch and smaller objects should be good with a laser/camera based approach. TBC...
- All of the sides have a defined opening, ready to accept a door panel for closing them off. As the print head can go beyond the door opening, any potential door panel would need to accomodate this.
- I painted mine in white, gloss paint. What colour will you paint yours or will you leave it natural with/without lacquer?
- For now I used screw terminal blocks for connecting the wires of the print head assembly to machine. This makes a lot of sense as I am still experimenting. As an example, only very recently I have connected a distance sensor. No problem, extra 3-way terminal block fitted and I was away! In the long run I would like to replace the blocks with a neat connector. Suggestions are welcome!



## Comments

[50 comments](#) [Add Comment](#)

[view all 66 comments](#)



**RTegelbeckers** says:

Oct 21, 2014. 2:42 AM [REPLY](#)

Hi Warren,

I assume you refer to the aluminium tubes on top of the carriage. The tubes are cut from a length of aluminium tube (8mm Outside Diameter x 1mm wall thickness) I obtained from my local DIY shop. I cut them to just over 14mm and file them down afterwards, so they are exactly 14.0mm (check with callipers). Finally, I drill them out to 6 or 6.5mm to fit the carriages. I am not yet selling the plastic bits, but should do so soon.



**WarrenB1** says:

Oct 20, 2014. 4:31 PM [REPLY](#)

Hello Richard,

I'm trying to put together the bits and pieces to build this printer. I really like the Delta look. I have gotten the same Igus rail and carriage system you used with the exception of the extensions on the carriage in the center photograph. Is that an accessory for the carriage? If so do they have a part number or location I might get them? Also I know you are very busy building for the Kickstarter program (congratulations on that) but I will be in need of the plastic bits - can you give me a price?

Thanks

Warren



**caizprua46** says:

Sep 23, 2014. 5:54 PM [REPLY](#)

Hi, I would like to know if I can use a raspberry pi as a controller instead of the ramps.



**RTegelbeckers** says:

Sep 24, 2014. 12:04 AM [REPLY](#)

Hi. A RPI does not have a lot of IO ports and it is not necessarily good at doing real time stuff, as it uses a Linux operating system. Of course, there is also LinuxCNC, which is actually used for doing real-time stuff. However, for 3D printers (in 2014) the majority of available OS firmware is written for 8 bit AVR or 32 bit ARM based electronics. A RPI can still be useful for 3D printing, as it can act as a host. Visit Octoprint.org to check out the possibilities...



**KhalidK** says:

Aug 1, 2014. 12:52 PM [REPLY](#)

Hi, gr8 job. I wish if you can post updated CAD model here so that i can machine the structure on My CNC. I see that many plastic parts can also be machined on CNC,

I am sorry the kickstarter can not get the funds within the time.



**bpetno** says:

Jul 4, 2014. 4:53 AM [REPLY](#)

What type of distance sensor did you equip your machine with as you mentioned at the end of your instructable and how did it work? I am thinking about trying this and am curious of the results!



**RTegelbeckers** says:

Jul 9, 2014. 4:47 PM [REPLY](#)

Hi Braden, the sensor I used is this one:

<http://www.wayengineer.com/infrared-sensor-for-int...>

I have not yet tried auto levelling as I do not really need it.

Many consumer level printers lack rigidity, which results in the need for frequent re-calibration. The DeltaTrix frame has been designed to address this issue, by using a very sturdy frame structure.

Does your own printer need to be re-calibrated often? It looks like you copied the basic frame structure from my own design, so I expect it to be fairly rigid as well.



**markmedown** says:

Jun 10, 2014. 1:53 PM [REPLY](#)

Hi there,

I was just wondering if you are going to be starting a new Kickstarter at any point soon. I would love to get a kit of this build as it is hard for me to do the wood working myself and I don't have any connections which would make this easy for me to do. Unfortunately I missed your last Kickstarter and cannot make a pledge. I already own a 3D printer but I absolutely love your design!



**RTegelbeckers** says:

Jun 10, 2014. 2:12 PM [REPLY](#)

Hi. Many thanks for your interest! The plan is to send the kits for the current Kickstarter in August, after which I aim to launch a new Kickstarter. Right now the production need to be set up, but for the new campaign everything will already be in place. This should lead to shorter lead times. Thanks again, and check back in a little while!



**markmedown** says:

Jun 10, 2014. 10:10 PM [REPLY](#)

Awesome! Thanks for the quick reply!

I can't wait to see the changes reflected on the original Instructable that you have up. I love the new look of the printers :)

**ablazedJae** says:

May 30, 2014. 8:29 AM [REPLY](#)

I really want to make one of these since i can't no longer invest in the project on kickstarter :(

i am having difficulties getting the exact parts though, can you please update the BOM ? i am having difficulty finding info from pulley and below please and thank you

much appreciated, i love this design more than any other 3d printer in the market, thank in advance

... peace & love from New York



**RTegelbeckers** says:

May 30, 2014. 11:53 AM [REPLY](#)

Hi! At the moment I am very busy sorting out the kits for Kickstarter. Part of the work is in finalising some of the latest design improvements and documenting everything I have changed/updated since publishing the initial Instructable. By the time I will be sending out the kits, I will update the Instructable (including the BOM) so it will reflect the latest version of the DeltaTrix 3D Printer. If you have any specific issues before the update, let me know what it is and I will try to sort it out! Also, I am considering launching a new Kickstarter after sending the kits for the current campaign...





**bpetno** says:

Mar 12, 2014. 5:53 PM [REPLY](#)

I just made my instructable if you want to check it out. Its called the delta twister 3d printer



 **MarkB16** says: Feb 6, 2014, 5:04 PM [REPLY](#)  
ok i have some questions 1 can i just router the frame because i dont have a cnc machine and how much money did you spend on this total

 **R Tegelbeckers** says: Feb 7, 2014, 2:02 AM [REPLY](#)  
To router the main parts for the frame would be fairly difficult, as accuracy is essential. The design has been created to make use of the precision a CNC can offer. As long as the panels are correct, the frame would align by itself. However, anything is possible! If I would not have had access to a CNC machine, I probably would have tried a router as well, making use of jigs or other methods for achieving the desired accuracy. In regards of cost, check my earlier reply to SeppePuelings (about a month ago, on this page).

 **EpicNickRocks** says: Jan 29, 2014, 3:23 PM [REPLY](#)  
Hello I have wanted a 3d printer since I heard about them but I couldn't afford one, I am 12 and have advanced electronic but basic arduino skills, could you please put a list of all the parts with specific names, it would make my year, Thanks.

 **R Tegelbeckers** says: Jan 30, 2014, 1:58 AM [REPLY](#)  
Hi,  
There is a BOM (Bill Of Materials) in step 6. Check it out and let me know if you need more information. Good luck!

 **bpetno** says: Jan 29, 2014, 4:06 AM [REPLY](#)  
Thanks i just sent you my email!

 **bpetno** says: Jan 27, 2014, 4:37 AM [REPLY](#)  
I am now ready for the testing phase of my 3d printer! Any chance you could send me those files for arduino? Thanks so much for putting this instructable up

 **R Tegelbeckers** says: Jan 28, 2014, 2:24 PM [REPLY](#)  
Hi, sorry not to have replied earlier...  
Send me a private message with your email, and I will send it to you. I still have not fully cleaned up the code, so I do not yet want to publish it properly.

 **rupin.chheda** says: Jan 2, 2014, 9:24 PM [REPLY](#)  
Looking at your design, I am hopeful now that a 3D printer is a possibility.  
Quick Question: How Do I procure parts when I dont have any one nearby who can 3d print? I do have someone who can laser cut acrylic or wood. Does the geometry of the 3d parts lend itself to a laser cut? which are the parts I can laser cut and which I can machine on a lathe or mill?

 **R Tegelbeckers** says: Jan 3, 2014, 12:20 AM [REPLY](#)  
The upright panels for the machine frame need to be machined with a (CNC) router. The other panels could possibly be cut by other means, but all the laser cutting machines I know of cannot cut the thickness required.  
  
In terms of the 3D printed parts, some could possible be cut on a (CNC) mill using a 3mm straight cutter: spacers for the switches, brackets for idler pulleys, linear carriage brackets (no. 1) for clamping belts, motor brackets, nozzle bracket. The linear carriage brackets (no. 2) for holding the rods and the end nozzle carriage would be difficult to machine.  
  
At the moment I am running a [Kickstarter](#) campaign where I am offering the DeltaTriX 3D Printer in kit form. It is also possible to just get hold of a panel set. If other options would be required, ask and I could add them, eg. 3D printed parts only, or panel set + 3D printed parts only. The Kickstarter will receive a big update in a few days, so make sure you keep an eye on it!

 **bpetno** says: Dec 30, 2013, 11:20 AM [REPLY](#)  
Thanks for the advice on the linear rods. I am using 8mm steel rods about 30 inches long. Would that present any sort of a problem? And thanks il wait until you publish the firmware

 **R Tegelbeckers** says: Dec 30, 2013, 2:17 PM [REPLY](#)  
The Rostock 3D printer uses similar size rods. There will most certainly be some deflection, but as plenty of peoples have been using Rostock type printers I am sure you will be able to get away with it.

 **bpetno** says: Dec 28, 2013, 8:59 PM [REPLY](#)  
Is there any way you could send me the arduino code that you made for this printer? Im really horrible when it comes to coding. Being 15 i havent taken coding classes and dont know how to make that part of the printer. If you dont want to give out that code its fine. Thanks!

 **R Tegelbeckers** says: Dec 29, 2013, 12:22 AM [REPLY](#)  
My firmware is not yet ready for publishing, as it needs some cleaning up. When the time comes - which should be fairly soon - I am planning to publish the documented code on this very Instructable. Together with the publishing of the code, I will include full instructions on how to setup the printer and how to make changes to the firmware. If you *really* cannot wait a few days, send me a Private Message with your email address and I will send the 'dirty' files by email. PS. As you are building a printer with linear rods, make sure the rods are thick enough and not too long, otherwise their deflection could become an issue.

 **bpetno** says: Dec 27, 2013. 8:12 PM [REPLY](#)  
Thanks to you i was able to design my own printer and am currently building it. Dude you are my hero. Haha im using linear rods instead of your slide though because i do not have access to a cnc machine. Thanks aton and good luck with your kickstarter!!!!

 **Vika84** says: Dec 28, 2013. 12:19 AM [REPLY](#)  
Nice one! Good luck with your build if you decide to publish it, send me a link!

 **RTegelbeckers** says: Dec 28, 2013. 12:25 AM [REPLY](#)  
Oops, I made the last comment whilst the PC was still logged on under my wife's account...

 **Instrumentalist** says: Dec 27, 2013. 8:53 AM [REPLY](#)  
I cant download the parts spreadsheet ? Theres something wrong with the download link I think ? Could you fix it please ? Thanks !

 **RTegelbeckers** says: Dec 27, 2013. 9:13 AM [REPLY](#)  
I just checked the link and it was working fine. Do you have Excel installed properly? I suggest trying again and if it still does not work, send me a Private Message with your email address and I will send it as as an attachment. Cheers, Richard.

 **RTegelbeckers** says: Dec 26, 2013. 10:08 AM [REPLY](#)  
The DeltaTrix 3D Printer is now available as a kit on Kickstarter!

 **RTegelbeckers** says: Dec 26, 2013. 10:08 AM [REPLY](#)  
The DeltaTrix 3D Printer is now available as a kit on Kickstarter!

 **RTegelbeckers** says: Dec 24, 2013. 4:02 PM [REPLY](#)  
Good news, my Kickstarter project has been accepted! I will be launching it on the 26th of December 2013 at 18:00 pm GMT. Have a wonderful festive season and the best wishes for 2014!

 **bpetno** says: Dec 21, 2013. 6:01 AM [REPLY](#)  
Sir what were the dimensions for the base and top. I am building one of these and dont have a CAD to open your designs in. Thanks!

 **RTegelbeckers** says: Dec 21, 2013. 6:56 AM [REPLY](#)  
There are a few free viewers available for download, which will be able to open the zipped \*.dwg file from Step 3. I recommend Autodesk DWG Trueview if you are running a Windows PC, but there are also other alternatives available from Autodesk.  
  
If you have to do with older hardware, like me, the latest viewers can be a little demanding. In this case it could be best to use the 2008 version of DWG Trueview, as located on [cnet.com](http://cnet.com).  
  
Use a viewer to take the measurements, straight from the model. If you have too much trouble with this, let me know as I might consider publishing proper engineering drawings for the panels.  
  
Good Luck!

 **RTegelbeckers** says: Dec 18, 2013. 3:24 PM [REPLY](#)  
Just to let you know, I just submitted a Kickstarter project and started a forum topic in relation to this.  
  
Let me know what you think about it!  
  
Thanks,  
Richard Tegelbeckers

 **SeppePuelings** says: Dec 13, 2013. 8:13 AM [REPLY](#)  
very nice, how much do you think it would cost to build one? wich arduino board did you use?

 **RTegelbeckers** says: Dec 15, 2013. 2:59 AM [REPLY](#)  
The biggest issues with building a printer, will be getting the CNC machined panels and the 3D printed parts. You will need access to a fairly large CNC machine and spend some time programming it. Also, as a standard 8x4ft piece of plywood will yield panels for three machines, there would be a lot of waste if you only needed one set. The best way to get 3D printed parts, is by using a friend's 3D printer. Online printing services would be fairly expensive (I actually did win my first set of parts in an [Instructables contest!](#)). As a one off, it would cost upwards of £550 for all the other bits, on top of the cost for CNC machined panels and 3D printed parts. As the electronics I used [RAMPS v1.4](#) and an [Arduino Mega 2560 R3](#). On my friend's machine we actually used a non-original, compatible Mega.





**Macflame** says:

Excellent! I now wish I had a CNC machine and 3D printer so I could make this :-)

Nov 24, 2013. 12:52 AM [REPLY](#)



**RTegelbeckers** says:

You could potentially make your own CNC machine, using one of many designs on this site. 3D printed parts could be done by a friend with a 3D printer, or they can be ordered from a place such as Sculpteo or Shapeways. - I did get my first printed parts for winning a contest on Instructables. - Alternatively, I will be making a kit available on Kickstarter VERY soon... ;-)

Nov 24, 2013. 1:47 AM [REPLY](#)



**Macflame** says:

Good luck with the Kickstarter. I am sure your printer will be very popular.

Dec 10, 2013. 11:58 PM [REPLY](#)



**RTegelbeckers** says:

Thanks!!!

Dec 11, 2013. 8:14 AM [REPLY](#)



**kalboon** says:

That thing is amazing, I designed something close to that about a year ago, yours is FAR superior lol, do you have even a ball park guess as to what the cost of the kits will be?

Nov 26, 2013. 10:34 PM [REPLY](#)



**RTegelbeckers** says:

Thanks for your kind remark. The cost of the kits will be revealed soon now, as the Kickstarter is almost ready to be launched...

Dec 10, 2013. 1:59 PM [REPLY](#)

**area36** says:

Hey great job on the instructables!! If you had a kit for this I would buy them all. Do you by chance have that code cleaned up? Also, what were the motors you used for the belts to move? Cant wait to build this keep up the good work!

Dec 10, 2013. 7:49 AM [REPLY](#)



**RTegelbeckers** says:

Thanks! Although the code is working, it still needs a bit of cleaning up. I also want to try the automatic levelling thing, using a simple and cheap optical sensor and a mirror in stead of glass print surface. The motors are 17HS19-1684S NEMA 17.

Dec 10, 2013. 2:02 PM [REPLY](#)

**sau2** says:

keep up the work, can't wait for the dev kits tobbe launched

Nov 19, 2013. 11:51 PM [REPLY](#)



**bpetno** says:

How much does this cost?? Absolutely brilliant. Im fifteen and am thinking about making one

Nov 17, 2013. 4:35 AM [REPLY](#)



**rakde** says:

I want a kit. Awesome

Nov 14, 2013. 8:17 PM [REPLY](#)

[view all 63 comments](#)