



800mA Standalone Linear Li-Ion Battery Charger with Thermal Regulation in SOT23-5

General Description

The LP4060 is a complete constant-current/constant-voltage linear charger for single cell lithium-ion batteries. Its SOT23-5 package and low external component count make the LP4060 ideally suited for portable applications. Furthermore, the LP4060 is specifically designed to work within USB power specifications. No external sense resistor is needed, and no blocking diode is required due to the internal MOSFET architecture. Thermal feedback regulates the charge current to limit the die temperature during high power operation or high ambient temperature. The charge voltage is fixed at 4.2V/4.35V, and the charge current can be programmed externally with a single resistor. The LP4060 automatically terminates the charge cycle when the charge current drops to 1/10th the programmed value after the final float voltage is reached. When the input supply (wall adapter or USB supply) is removed, the LP4060 automatically enters a low current state, dropping the battery drain current to less than 1µA. Other features include charge current monitor, automatic recharge and a status pin to indicate charge termination and the presence of an input voltage.

Features

- ◆ Programmable Charge Current Up to 800mA
- ◆ No MOSFET, Sense Resistor or Blocking Diode Required
- ◆ Complete Linear Charger in SOT23-5 Package for Single Cell Lithium-ion Batteries
- ◆ Constant-Current/Constant-Voltage Operation with Thermal Regulation to Maximize
- ◆ Charge Rate Without Risk of Overheating
- ◆ 4.2V Charge Voltage with ± 1% Accuracy
- ◆ Charge Current Monitor Output for Gas Gauging
- ◆ Automatic Recharge
- ◆ 2.9V Trickle Charge Threshold
- ◆ C/10 Charge Termination
- ◆ 1uA Supply Current in Shutdown
- ◆ Output OCP
- ◆ Charging OTP

Order Information

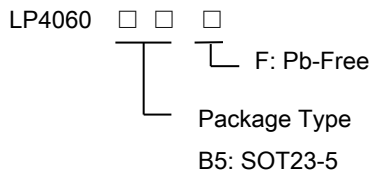

Applications

- ◇ Portable Media Players/MP3 players
- ◇ Cellular and Smart mobile phone
- ◇ PDA/DSC
- ◇ Bluetooth Applications

Typical Application Circuit

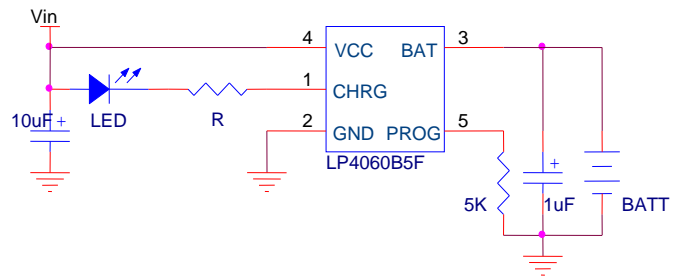

Marking Information

Part	Marking	Package	Shipping
LP4060B5F	LP4060 BBYWX	SOT23-5	3K/REEL
Marking indication: Y:Production year W:Production week X:Production batch.			



Functional Pin Description

Package Type	Pin Configurations
SOT23-5	<p style="text-align: center;">TOP VIEW</p> <p style="text-align: center;">SOT23-5</p>

Pin Description

Pin	Name	Description
1	CHRG	Open-Drain Charge Status Output. When the battery is charging, the CHRG pin is pulled low by an internal N-channel MOSFET. When the LP4060 detects an under voltage lockout condition or charge complete, CHRG is forced high impedance.
2	GND	Ground.
3	BAT	Charge Current Output. Provides charge current to the battery and regulates the final float voltage to 4.2V/4.35V. An internal precision resistor divider from this pin sets the float voltage.
4	VCC	Positive Input Supply Voltage. Provide power to the charger. VCC can range from 3.9V to 6.5V and should be bypassed with at least a 1µF capacitor. When VCC drops to within 30mV of the BAT pin voltage, the LP4060 enters shutdown mode, dropping IBAT to less than 1µA.
5	PROG	Charge Current Program and Charge Current Monitor Pin. The charge current is programmed by connecting a 1% resistor, R _{PROG} , to ground. When charging in constant-current mode, this pin serves to 1V. In all modes, the voltage on this pin can be used to measure the charge current using the following formula: $I_{BAT} = 1000/R_{PROG}$



Function Block Diagram

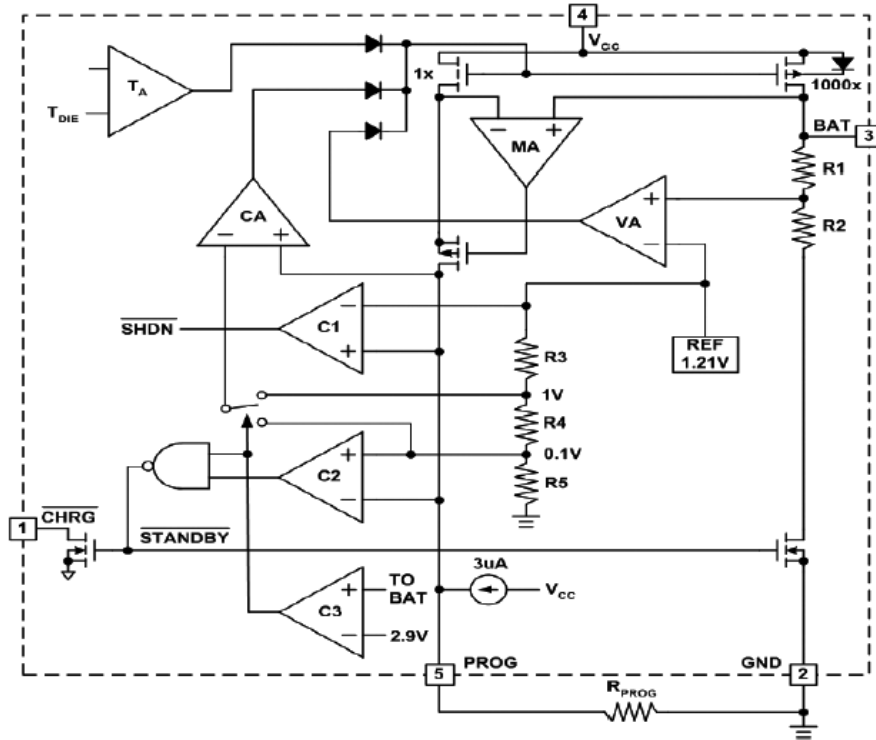

Absolute Maximum Ratings ^{Note 1}

◇ Input to GND(VCC)	-----	-0.3V to 7V
◇ Other Pin to GND	-----	-0.3V to 6V
◇ BAT Pin Current	-----	800mA
◇ BAT Short-circuit Duration	-----	Continuous
◇ PROG Pin Current	-----	800uA
◇ Maximum Junction Temperature	-----	125°C
◇ Operating Ambient Temperature Range (T _A)	-----	-40°C to 85°C
◇ Storage Temperature	-----	-65°C to 165°C
◇ Maximum Soldering Temperature (at leads, 10 sec)	-----	260°C

Note 1. Stresses beyond those listed under "Absolute Maximum Ratings" may cause permanent damage to the device. These are stress ratings only, and functional operation of the device at these or any other conditions beyond those indicated in the operational sections of the specifications is not implied. Exposure to absolute maximum rating conditions for extended periods may affect device reliability.

Thermal Information

◇ Maximum Power Dissipation (SOT23-5, P _D , T _A =25°C)	-----	0.5W
◇ Thermal Resistance (SOT23-5, θ _{JA})	-----	200°C/W

ESD Susceptibility

◇ HBM(Human Body Mode)	-----	2KV
◇ MM(Machine Mode)	-----	200V



Electrical Characteristics

($T_A=25^{\circ}\text{C}$. $V_{CC}=5\text{V}$, unless otherwise noted.)

Symbol	Parameter	Condition	Min	Typ	Max	Units
V_{CC}	Adapter/USB Voltage Range		3.9	5	6	V
I_{CC}	Input Supply Current	Charge Mode, $R_{PROG}=10\text{k}$		300	1000	μA
		Standby Mode (Charge Terminated)		50	200	
		Shutdown Mode ($R_{PROG}=\text{NC}$, $V_{CC} < V_{BAT}$, or $V_{CC} < V_{UV}$)		50	200	
V_{FLOAT}	Regulated Output (Float) Voltage	$0^{\circ}\text{C} \leq T_A \leq 85^{\circ}\text{C}$	4.158	4.2	4.242	V
I_{BAT}	BAT Pin Current	$R_{PROG}=10\text{k}$, Current Mode	80	100	120	mA
		$R_{PROG}=2\text{k}$, Current Mode	400	500	600	mA
		Standby Mode, $V_{BAT}=4.2\text{V}$ Shutdown Mode ($R_{PROG}=\text{NC}$) Sleep Mode, $V_{CC}=0\text{V}$		± 1 ± 1 -0.1	± 2 ± 2 -1	μA
V_{TRIKL}	Trickle Charge Threshold Voltage	$R_{PROG}=10\text{k}$, V_{BAT} Rising	2.8	2.9	3.0	V
V_{TRHYS}	Trickle Charge Hysteresis Voltage	$R_{PROG}=10\text{k}$		100		mV
I_{TRIKL}	Trickle charge current	$V_{BAT} < V_{TRIKL}$		30		mA
V_{UV}	V_{CC} Under Voltage Lockout Threshold	From V_{CC} Low to High	3.7	3.8	3.9	V
V_{UVHYS}	V_{CC} Under Voltage Lockout Hysteresis			300		mV
V_{ASD}	$V_{CC}-V_{BAT}$ Lockout Threshold Voltage	V_{CC} from Low to High	70	100	140	mV
		V_{CC} from High to Low	5	30	50	mV
V_{PROG}	PROG Pin Voltage	$R_{PROG}=10\text{k}$, Charge Mode		1		V
V_{CHRG}	CHRG Pin Output Low Voltage	$I_{CHRG}=5\text{mA}$		0.35	0.6	V
I_{CHRG}	CHRG Pin Weak Pull-Down Current	$V_{CHRG}=5\text{V}$			5	μA
ΔV_{RECHRG}	Recharge Battery Threshold Voltage	$V_{FLOAT}-V_{RECHRG}$	100	150	200	mV
T_{LIM}	Junction Temperature in Constant Temperature Mode			125		$^{\circ}\text{C}$
R_{ON}	Power FET "ON" Resistance (Between V_{CC} and BAT)			400		$\text{m}\Omega$
t_{SS}	Soft-Start Time	$I_{BAT}=0$ to $I_{BAT}=1000\text{V}/R_{PROG}$		100		μs
t_{RECHRG}	Recharge Comparator Filter Time	V_{BAT} High to Low		2		ms



Application Information

The LP4060 is a single cell lithium-ion battery charger using a constant-current/constant-voltage algorithm. It can deliver up to 800mA of charge current (using a good thermal PCB layout) with a final float voltage accuracy of $\pm 1\%$. The LP4060 includes an internal P-channel power MOSFET and thermal regulation circuitry. No blocking diode or external current sense resistor is required; thus, the basic charger circuit requires only three external components. Furthermore, the LP4060 is capable of operating from a USB power source.

Normal Charge Cycle

A charge cycle begins when the voltage at the VCC pin rises above the UVLO threshold level and a 1% program resistor is connected from the PROG pin to ground or when a battery is connected to the charger output. If the BAT pin is less than 2.9V, the charger enters trickle charge mode. When the BAT pin voltage rises above 2.9V, the charger enters constant-current mode, where the programmed charge current is supplied to the battery. When the BAT pin approaches the final float voltage (4.2V), the LP4060 enters constant-voltage mode and the charge current begins to decrease. The charge cycle ends when the charge current drops to 1/10 of the programmed value.

Programming Charge Current

The charge current is programmed using a single resistor from the PROG pin to ground. The battery charge current is 1000 times the current out of the PROG pin. The program resistor and the charge current are calculated using the following equations:

$$R_{\text{PROG}} = 1000V / I_{\text{BAT}} \quad I_{\text{BAT}} = 1000V / R_{\text{PROG}}$$

The charge current out of the BAT pin can be determined at any time by monitoring the PROG pin voltage using the following equation:

$$I_{\text{BAT}} = V_{\text{PROG}} / R_{\text{PROG}} \times 1000$$

Charge Termination

A charge cycle is terminated when the charge current falls to 1/10th the programmed value after the final float voltage is reached. This condition is detected by using an internal, filtered comparator to monitor the PROG pin. When the PROG pin voltage falls below 100mV for longer than t_{TERM} (typically 1ms), charging is terminated. The charge current is latched off and the LP4060 enters standby mode, where the input supply current drops to 200 μ A. When charging, transient loads on the BAT pin can cause the PROG pin to fall below 100mV for short periods of time before the DC charge current has dropped to 1/10th the programmed value. The 1ms filter time (t_{TERM}) on the termination comparator ensures that transient loads of this nature do not result in premature charge cycle termination. Once the average charge current drops below 1/10th the programmed value, the LP4060 terminates the charge cycle and ceases to provide any current through the BAT pin. In this state, all loads on the BAT pin must be supplied by the battery. The LP4060 constantly monitors the BAT pin voltage in standby mode. If this voltage drops below the 4.05V recharge threshold (V_{RECHRG}), another charge cycle begins and current is once again supplied to the battery. To manually restart a charge cycle when in standby mode, the input voltage must be removed and reapplied.

Charge Status Indicator (CHRG)

The charge status output has two different states: strong pull-down ($\sim 5\text{mA}$) and high impedance. The strong pull-down state indicates that the LP4060 is in a charge cycle. Once the charge cycle has terminated, the pin state is determined by under voltage lockout conditions. High impedance indicates that the charge cycle complete or the LP4060 is in under voltage lockout mode: either V_{CC} is less than 100mV above the BAT pin voltage or insufficient voltage is applied to the VCC pin. A microprocessor can be used to distinguish between these two states.



Charge Termination

An internal thermal feedback loop reduces the programmed charge current if the die temperature attempts to rise above a preset value of approximately 125°C. This feature protects the LP4060 from excessive temperature and allows the user to push the limits of the power handling capability of a given circuit board without risk of damaging the LP4060. The charge current can be set according to typical (not worst-case) ambient temperature with the assurance that the charger will automatically reduce the current in worst-case conditions. SOT power considerations are discussed further in the Applications Information section.

Under voltage Lockout (UVLO)

An internal under voltage lockout circuit monitors the input voltage and keeps the charger in shutdown mode until V_{CC} rises above the under voltage lockout threshold. The UVLO circuit has a built-in hysteresis of 300mV. Furthermore, to protect against reverse current in the power MOSFET, the UVLO circuit keeps the charger in shutdown mode if V_{CC} falls to within 30mV of the battery voltage. If the UVLO comparator is tripped, the charger will not come out of shutdown mode until V_{CC} raises 100mV above the battery voltage.

Manual Shutdown

At any point in the charge cycle, the LP4060 can be put into shutdown mode by removing R_{PROG} thus floating the PROG pin. This reduces the battery drain current to less than 1 μ A and the supply current to less than 50 μ A. A new charge cycle can be initiated by reconnecting the program resistor. In manual shutdown, the CHRГ pin is in a weak pull-down state as long as V_{CC} is high enough to exceed the UVLO conditions. The CHRГ pin is in a high impedance state if the LP4060 is in under voltage lockout mode: either V_{CC} is within 100mV of the BAT pin voltage or insufficient voltage is applied to the VCC pin.

Automatic Recharge

Once the charge cycle is terminated, the LP4060 continuously monitors the voltage on the BAT pin using a comparator with a 2ms filter time (t_{RECHRG}). A charge cycle restarts when the battery voltage falls below 4.05V (which corresponds to approximately 80% to 90% battery capacity). This ensures that the battery is kept at or near a fully charged condition and eliminates the need for periodic charge cycle initiations. CHRГ output enters a strong pull-down state during recharge cycles.

Power Dissipation

The conditions that cause the LP4060 to reduce charge current through thermal feedback can be approximated by considering the power dissipated in the IC. Nearly all of this power dissipation is generated by the internal MOSFET—this is calculated to be approximately:

$$P_D = (V_{CC} - V_{BAT}) \times I_{BAT}$$

Where P_D is the power dissipated, V_{CC} is the input supply voltage, V_{BAT} is the battery voltage and I_{BAT} is the charge current. The approximate ambient temperature at which the thermal feedback begins to protect the IC is:

$$T_A = 125^\circ\text{C} - P_D \theta_{JA}$$

$$T_A = 125^\circ\text{C} - (V_{CC} - V_{BAT}) \times I_{BAT} \times \theta_{JA}$$

VCC Bypass Capacitor

Many types of capacitors can be used for input bypassing; however, caution must be exercised when using multilayer ceramic capacitors. Because of the self-resonant and high Q characteristics of some types of ceramic capacitors, high voltage transients can be generated under some start-up conditions, such as connecting the charger input to a live power source. Adding a 1.5 Ω resistor in series with an X5R ceramic capacitor will minimize start-up voltage transients.



Packaging Information

SOT23-5

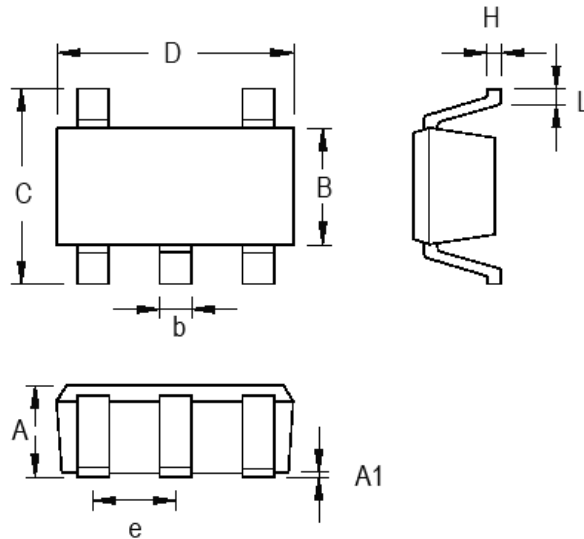

Symbol	Dimensions In Millimeters		Dimensions In Inches	
	Min	Max	Min	Max
A	0.889	1.295	0.035	0.051
A1	0.000	0.152	0.000	0.006
B	1.397	1.803	0.055	0.071
b	0.356	0.559	0.014	0.022
C	2.591	2.997	0.102	0.118
D	2.692	3.099	0.106	0.122
e	0.838	1.041	0.033	0.041
H	0.080	0.254	0.003	0.010
L	0.300	0.610	0.012	0.024

SOT-23-5 Surface Mount Package