

THE
**WOOD
KNIGHT**



MISSION SIDE TABLE

Version 1.2

Copyright © 2019 The Wood Knight, <http://www.thewoodknight.com>

Cut/Parts List

PER 1 (ONE) SIDE TABLE

	NAME	WIDTH	THICKNESS	LENGTH	QTY	NOTES
Frame	Legs	40 mm	40 mm	595 mm	4	Preferably rift sawn grain
	Long Aprons (Top & Middle)	40 mm	20 mm	380* mm	4	
	Long Aprons (Bottom/Curved)	45 mm	20 mm	380* mm	2	Curve start at 45mm, goes to 35mm
	Short Aprons (Top)	40 mm	20 mm	290* mm	2	
	Short Aprons (Bottom/Curved)	45 mm	20 mm	290* mm	2	Curve start at 45mm, goes to 35mm
Decoration	Stiles	40 mm	10 mm	470* mm	6	
Panels	Top	410 mm	25 mm	500 mm	1	
	Shelf	380 mm	12 mm	340 mm	2	Cut To fit

There are a total of **6 (six)** long aprons, and **4 (four)** short aprons

Parts with an * in the dimension should be adjusted based on the type of joinery used. For dowels and dominoes/loose tenons, this number is correct, but for mortise & integral tenon you will need to add 25 mm on each end (50 mm total)

Overview

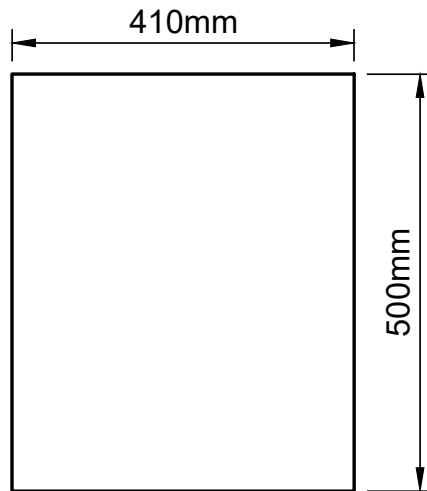
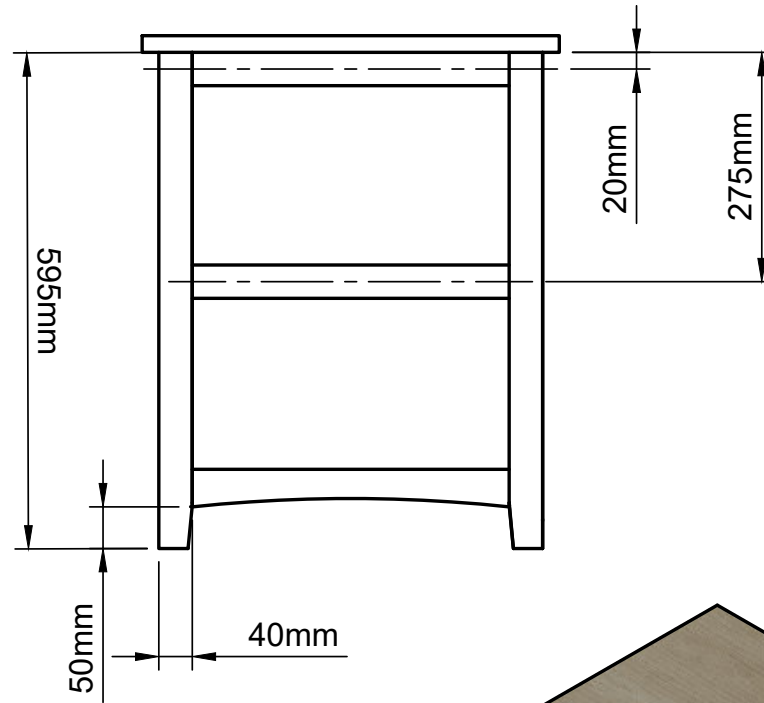
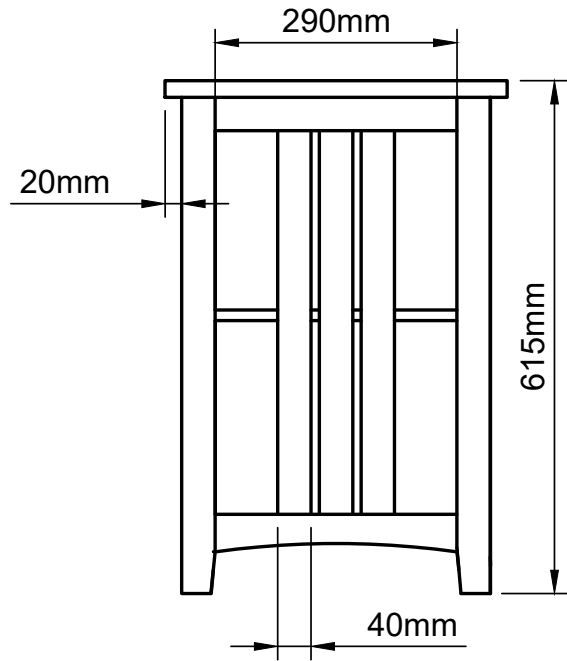

Short Sides

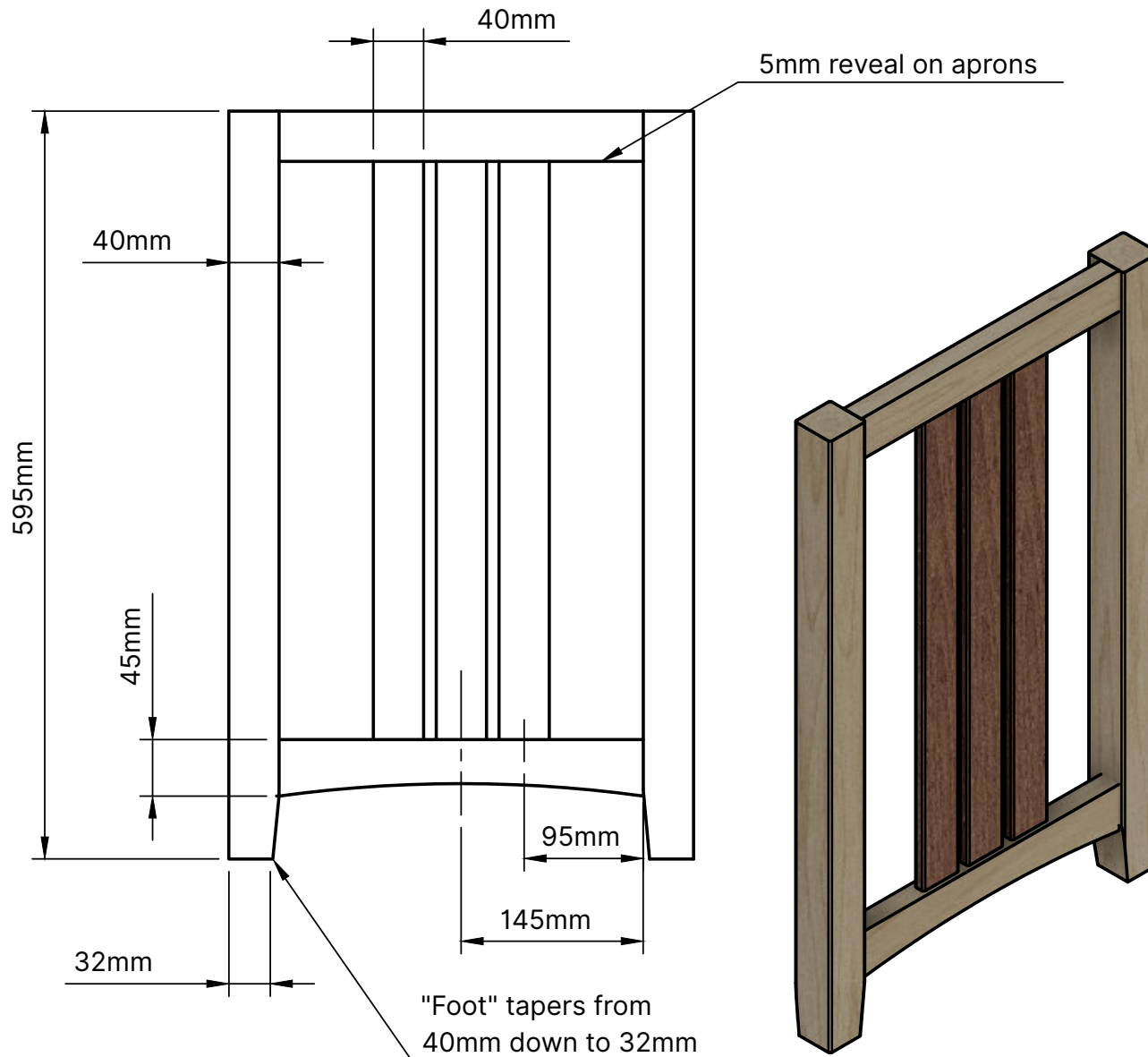

**TWO SHORT SIDES
PER SIDE TABLE**

Lower Aprons

Short Apron

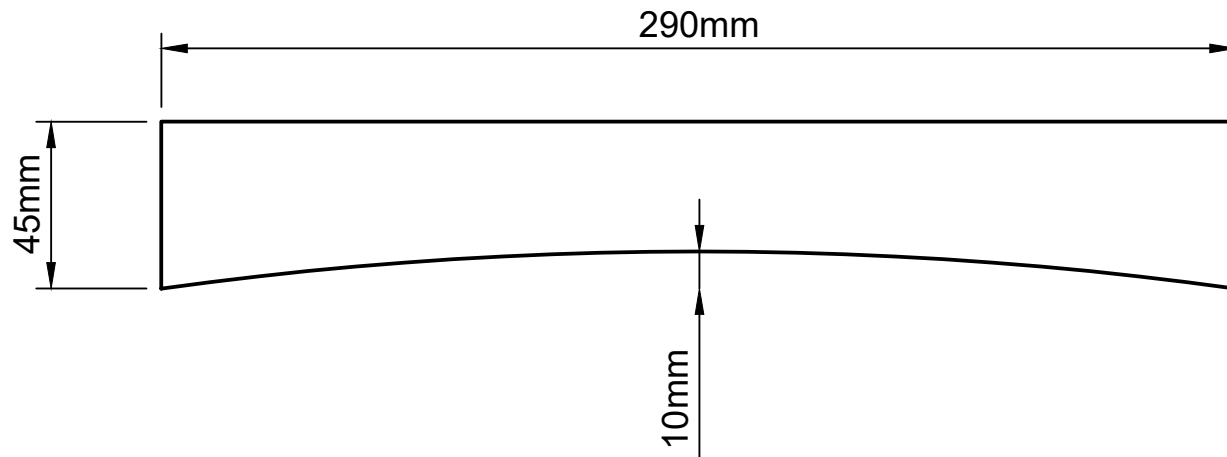

Long Apron

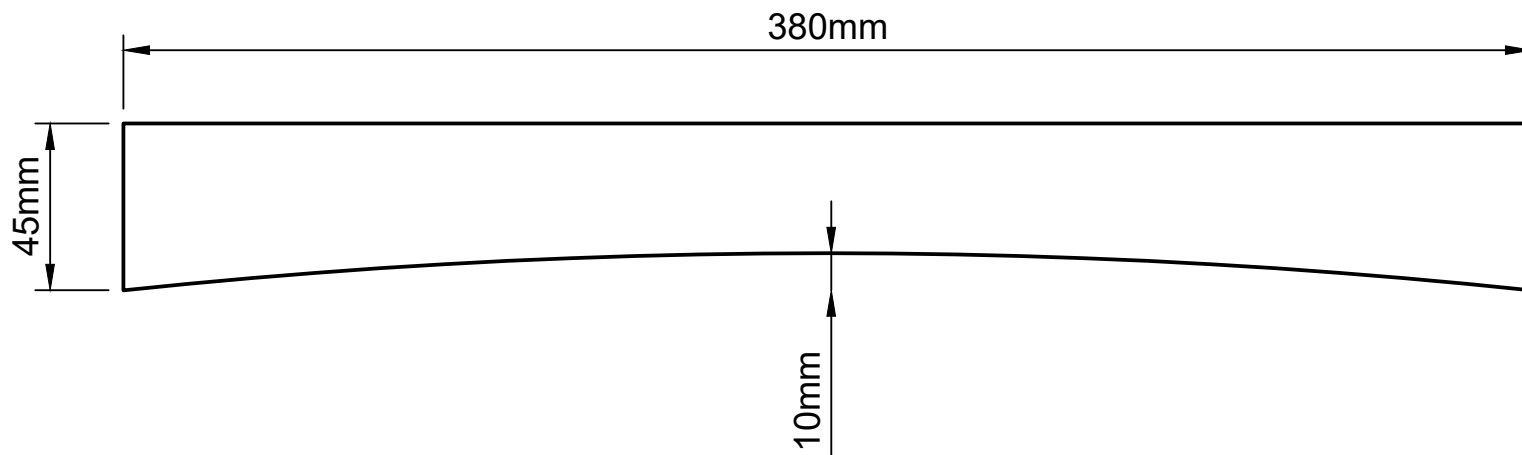

Shelves

End profile view of long aprons

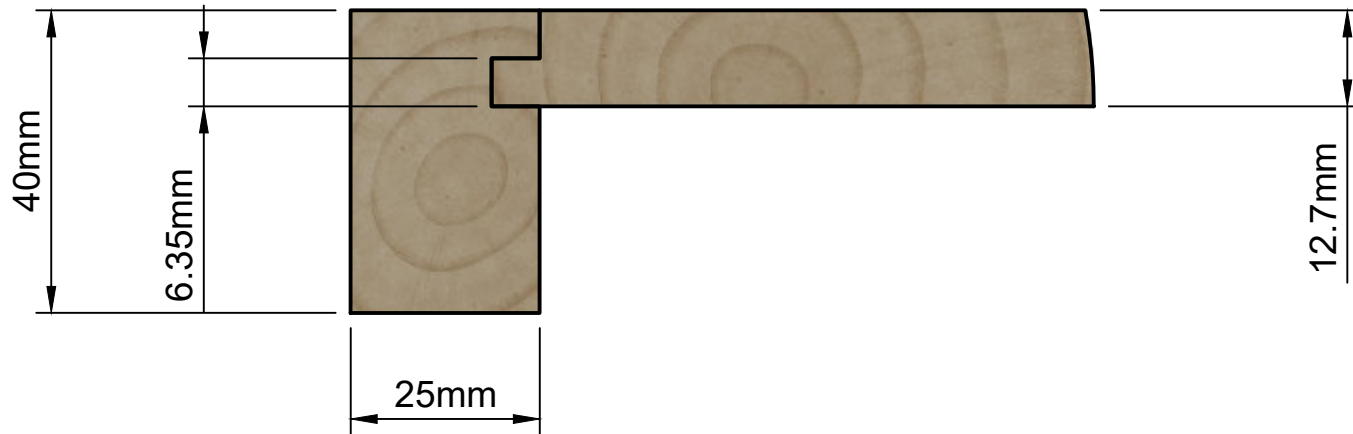
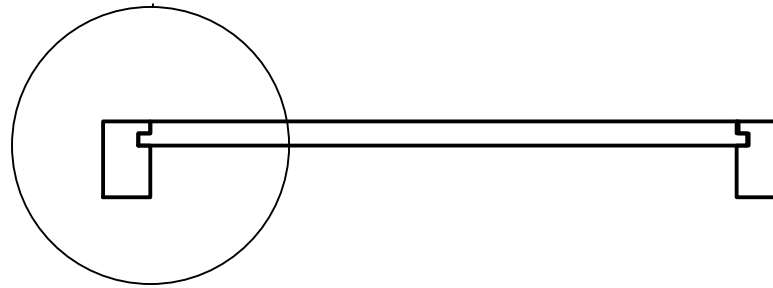

Shelves are rebated (and floating) in the long aprons