

HORIZONTAL BAND SAW

VERSION 3.1



AUTODESK
PIER 9

HORIZONTAL BAND SAW

MACHINE
CONTROLS

VERSION 3.1

THE HORIZONTAL BAND SAW MAKES STRAIGHT AND ANGLE CUTS IN LARGE MATERIAL.

P. 2

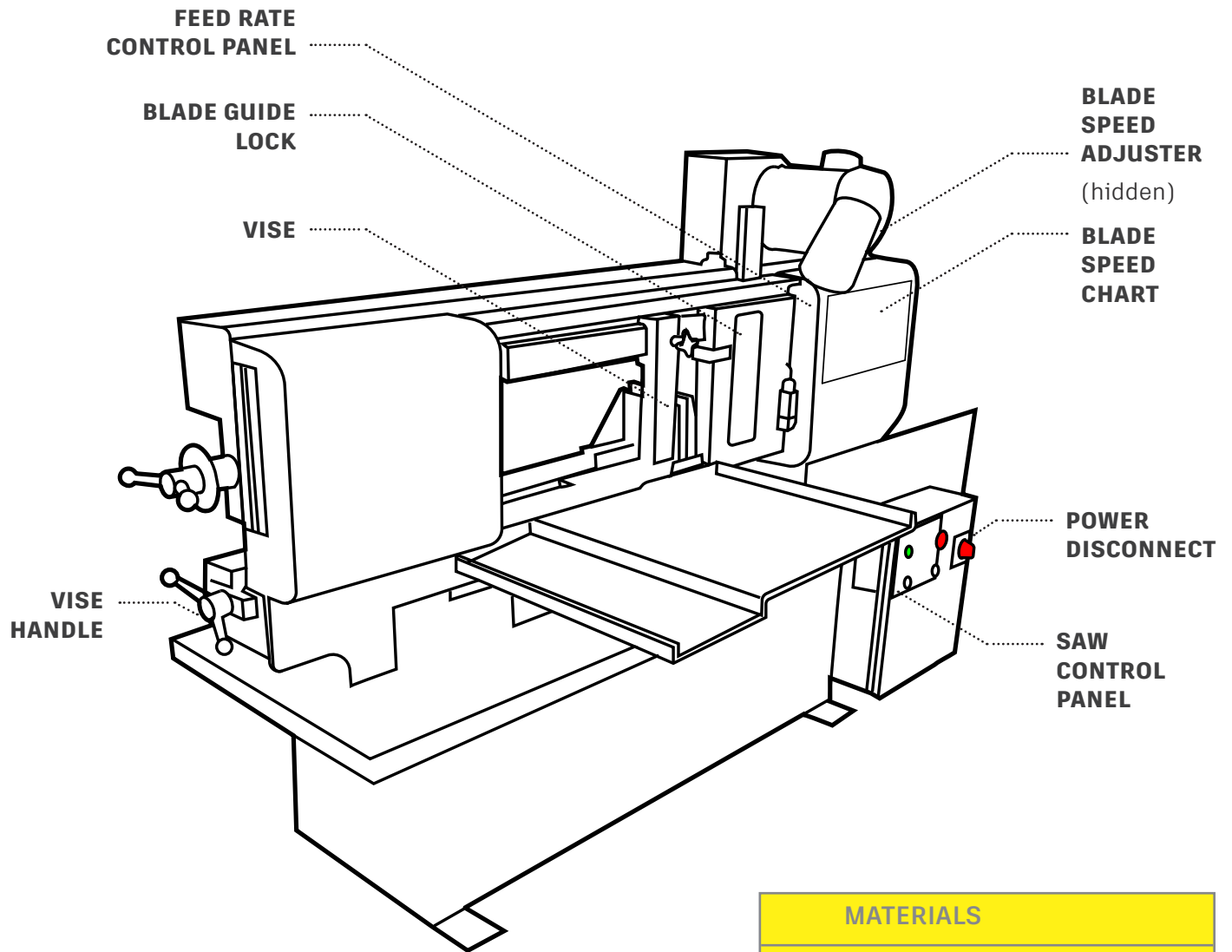

MATERIALS

i ALLOWED MATERIALS

- + Metal
- + Plastic
- + PVC

⊗ BANNED MATERIALS

- + Wood
- + Carbon fiber and composites

? SEE SHOP STAFF FIRST

- + All other materials

HORIZONTAL BAND SAW

KEEP IT SAFE

VERSION 3.1

USE PERSONAL PROTECTIVE EQUIPMENT WHEN OPERATING THE HORIZONTAL BAND SAW.

P. 3

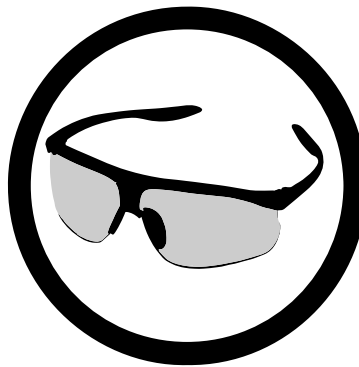

Always wear safety glasses.

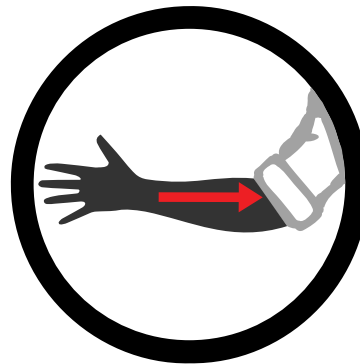

Always wear short sleeves, or rolled sleeves, pull back and tuck in long hair, remove jewelry and lanyards, etc. Do not wear gloves.

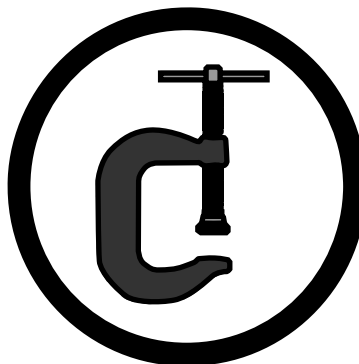
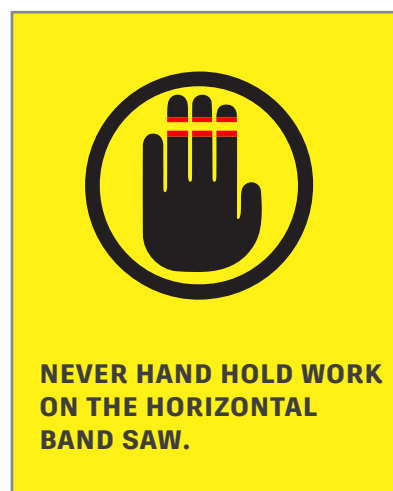

Using the built in vise is required for every cut.

THE BLADE SPEED & FEED RATE MUST BE ADJUSTED FOR EACH CUT.

P. 4

BLADE SPEED CONTROLS

► **The saw must be running to change speed.**

1. Use the chart to determine blade speed.
2. Rotate the handle to change the blade speed.
3. Read the blade speed on the scale.

Slow: Mild steel or stainless steel

Fast: Aluminum and plastic

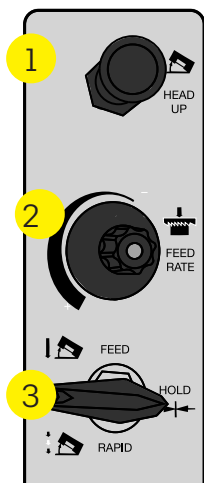
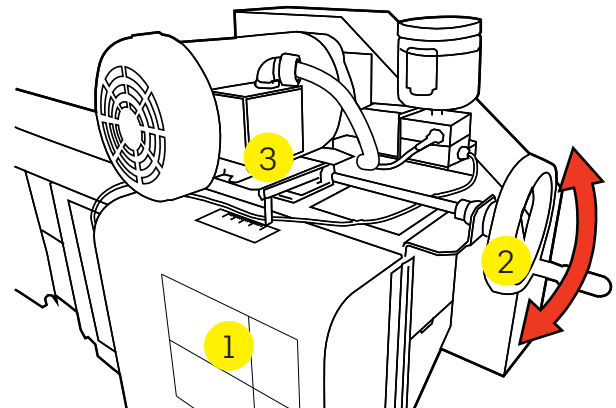

FEED RATE CONTROL PANEL

The feed rate control panel adjusts the vertical motion of the saw head.

1. Lifts the head, while the button is pushed.
2. Adjusts the feed rate.
3. Selects the mode of the head.
 - FEED - for cutting
 - HOLD - no motion
 - RAPID - for quickly dropping the head to the table; never for cutting

There are no hard stops for the three settings. Make sure the knob is pointed directly at the selected option.

ADJUSTING THE BLADE GUIDE FOR LARGE MATERIALS

To cut large materials, you may need to open the blade guides further.

1. Push the e-stop.
2. Loosen the lock knob.
3. With a flat-head screwdriver, loosen the screw near the blade directly under the lock knob.
4. Slide the blade guide to change the opening size.
5. Snug the lock knob.
6. Tighten the screw with the flat-head screwdriver.
7. Reset the e-stop.
8. Do a test cut to make sure blade is cutting squarely.

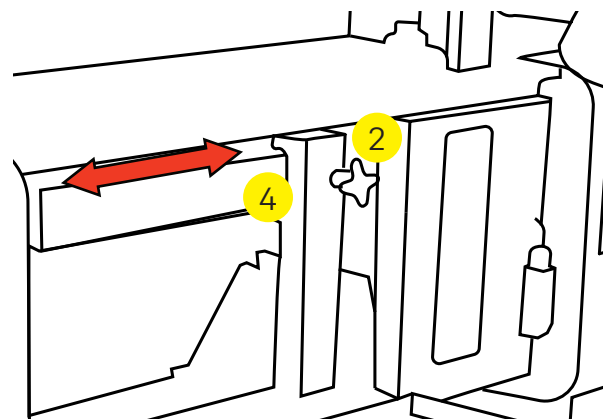

When finished, repeat these steps to return the guide to about a 6" opening.

HORIZONTAL BAND SAW

USING THE VISE &
CONTROL PANEL

VERSION 3.1

THE VISE MUST BE USED FOR EVERY CUT.

P. 5

USING THE VISE

Always use the vise; never hand hold material in the horizontal band saw.

1. Brush out the vise to make sure materials lie flat.
2. Turn on the laser to align your work.
 - ▶ Located on the saw control panel.
3. Lift the back of the vise and open it slightly wider than your work.
4. Set the tab at the end of the vise between two of the teeth in the clamping bar.
5. Turn the vise handle to clamp the work.
 - ▶ The vise handle is the lower handle.
 - ▶ The upper handle is for maintenance only.

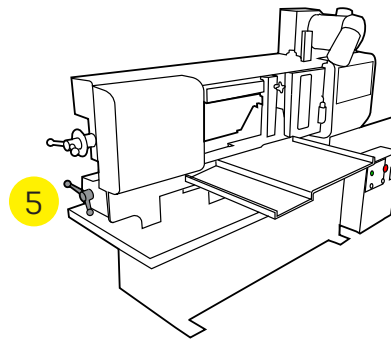
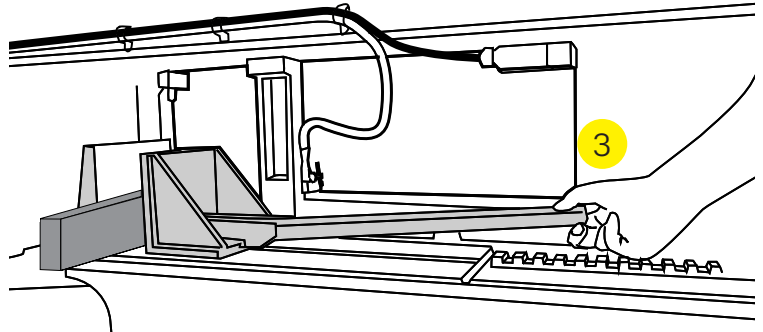

SAW CONTROL PANEL

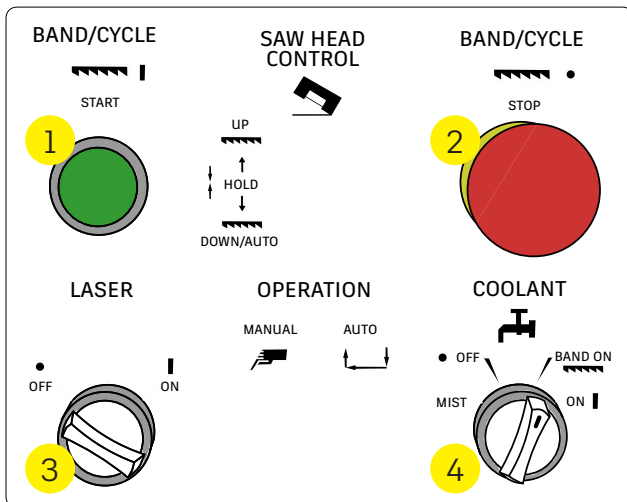

The saw control panel has 4 main functions.

1. Start button
2. Stop button
 - ▶ The blade will automatically stop when the saw finishes cutting.
3. Laser switch
 - ▶ Use to align the blade with the desired cut line.
4. Coolant switch
 - ▶ **BAND ON** for metals.
 - ▶ **OFF** for plastics.

HORIZONTAL BAND SAW

HANDS ON

VERSION 3.1

OPERATING THE HORIZONTAL BAND SAW.

P. 6

AREA AND MACHINE PREPARATION

1. Make sure there is sufficient room around the saw for your workpiece.
2. Set the feed selector to HOLD.
3. Turn the feed rate knob to zero.
4. Raise the blade above your material.
5. Press the e-stop.
6. Brush out the vise.
7. Adjust the blade guides for large material.
8. Put the material in the vise and tighten it.
9. Determine blade speed from the chart.

ALWAYS USE THE VISE; NEVER HAND HOLD MATERIAL.

MAKING THE CUT

1. Press the green BAND/CYCLE START button.
2. Adjust the blade speed.
3. Wait for coolant to start flowing.
 - ▶ Don't use coolant for cutting plastic.
4. Turn the feed rate selector to FEED.
5. Slowly increase the feed rate by rotating the feed rate knob.
 - ▶ The arm will start to drop at the set rate.
 - ▶ The blade should gently contact the material.
6. When the saw cuts all the way through the material, the saw will turn off.
 - ▶ If needed, press the red BAND/CYCLE STOP button.

DO NOT CUT IF THE COOLANT IS NOT FLOWING (WHEN CUTTING METAL).

CLEANUP

1. Return the blade guide to 6" if needed.
2. Lower the saw arm.
3. Set the feed selector to HOLD.
4. Set the feed rate to zero.
5. Brush off the vise and clean up the area.
6. Use Simple Green and shop rags on coolant spills.
 - ▶ Place the dirty rags in the red step cans for laundering.
7. Recycle scraps and put reusable pieces in the storage bin in the metal shop.

LOWER THE SAW ARM AND SET THE FEED RATE TO HOLD WHEN FINISHED.