



# PLAYGROUND

Supplies		
Item	Quantity	Description
1 ½"x4" C-Channel	2	109 ¼" long
2 ½" Diameter Round Pipe/Post	2	10 feet long
4x4x10'	6	Construction lumber
4x4x8'	1	Construction lumber
2x4x8'	12	Construction lumber
2x6x8'	1	Construction lumber

## Supplies Cont.

Item	Quantity	Description
1x6x8'	1	
1x4x8'	48	
2x3x8'	12	
4'x8'-1/2" Plywood	2	
Roof Shingles		To cover 64 sq feet of roof.
Swings	2	That include upper attachment to c-channel
Bar Swing	1	That include upper attachment to c-channel
Rock Climbing Piece	1	16" diameter half round
Slide	1	24" wide
1/8" thick flat bar	2	About 36" long
Handles	6	2 for rock climbing and 4 for ladder area
1/2" Bolts and Nuts		For swing attachment, flat bar, and c-channel attachment.
2 1/2" deck screws		
1 1/2" deck screws		
8" Round Concrete Form Tube		Total of 20 feet
Concrete		

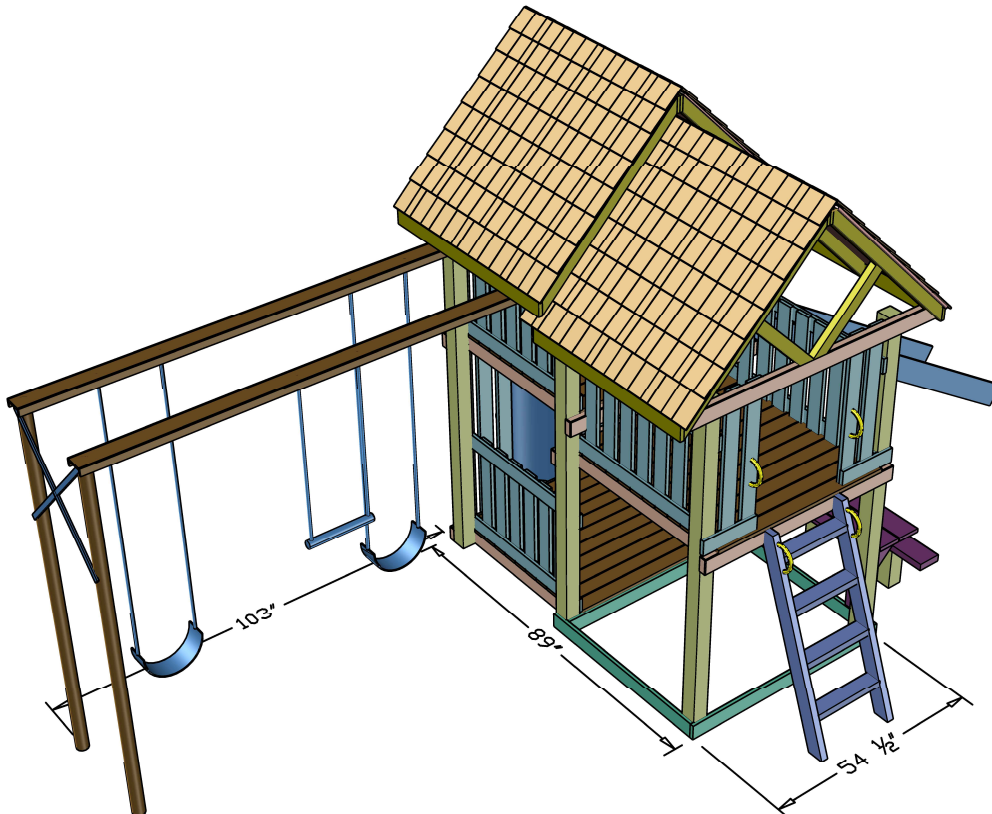

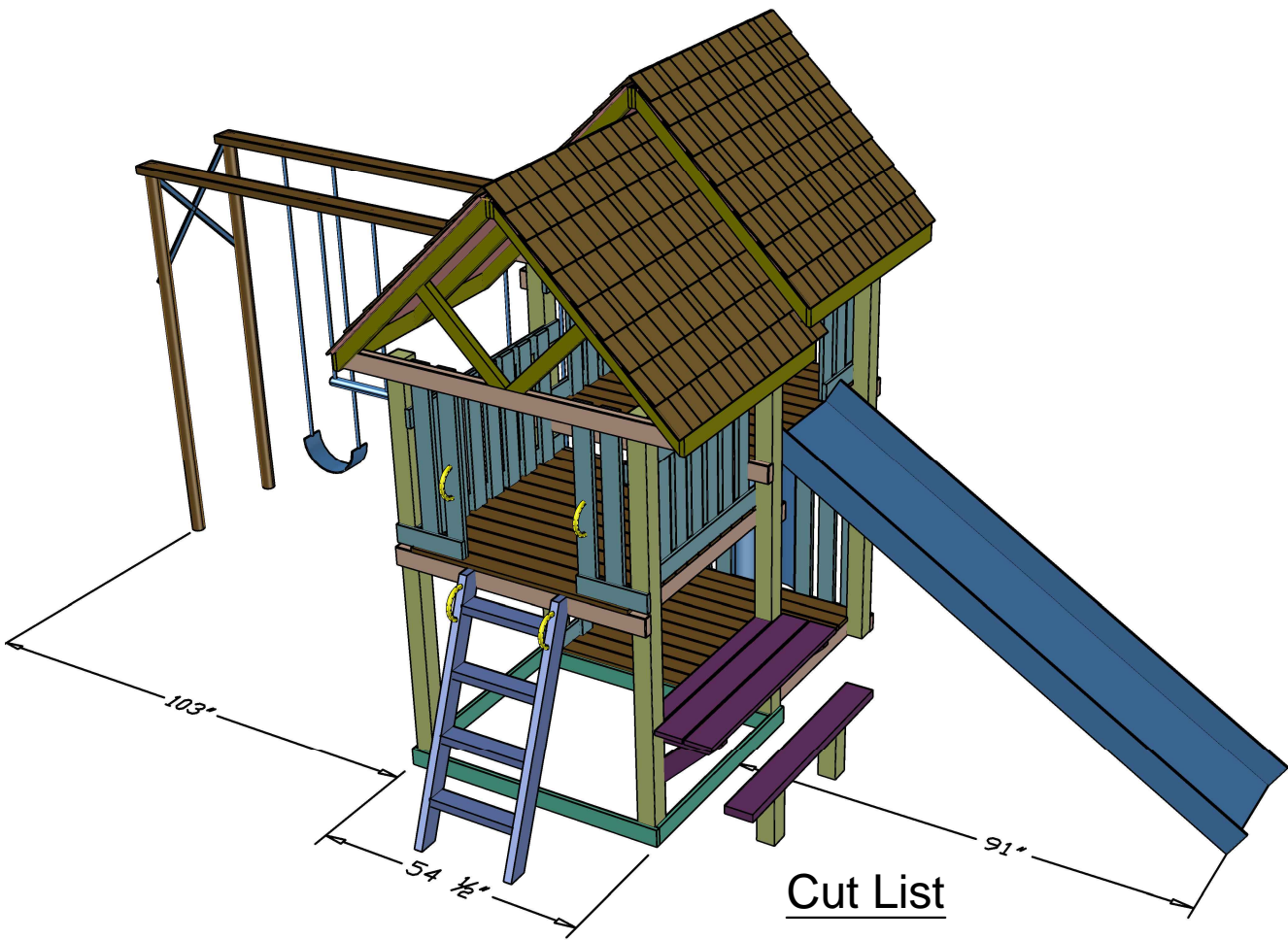

	109 1/4"	
1 1/2" x 4" C-CHANNEL	[Material bar]	
	109 1/4"	
1 1/2" x 4" C-CHANNEL	[Material bar]	
	111"	
2 1/2" PIPE 10'	[Material bar]	
	111"	
2 1/2" PIPE 10'	[Material bar]	
	116"	
4x4x10'	[Material bar]	
	116"	
4x4x10'	[Material bar]	
	116"	
4x4x10'	[Material bar]	
	116"	
4x4x10'	[Material bar]	
	109"	
4x4x10'	[Material bar]	
	109"	
4x4x10'	[Material bar]	
	36"	36"
4x4x8'	[Material bar]	
	53"	43"
2x4x8'	[Material bar]	
	53"	43"
2x4x8'	[Material bar]	



# Cut List

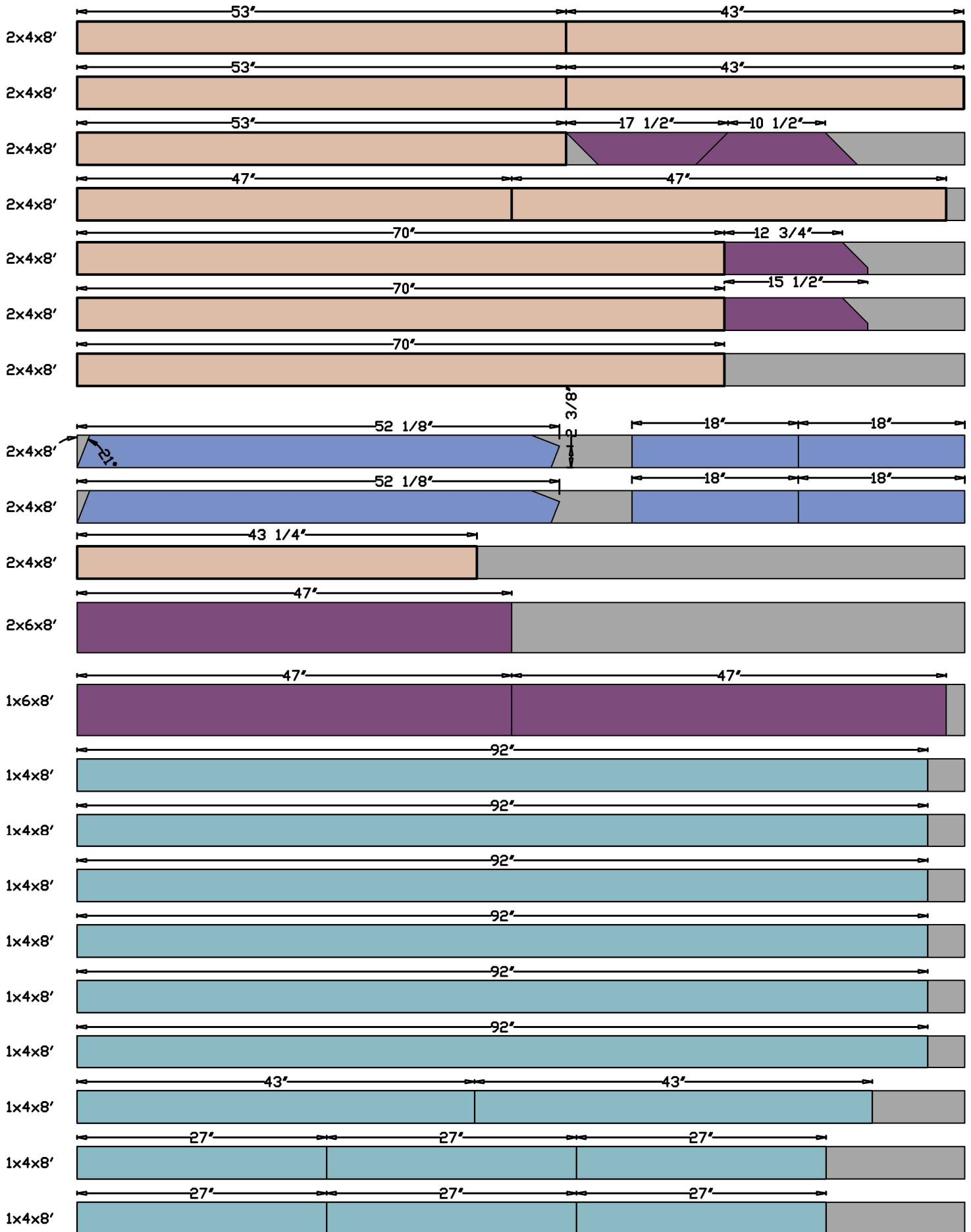



# Cut List

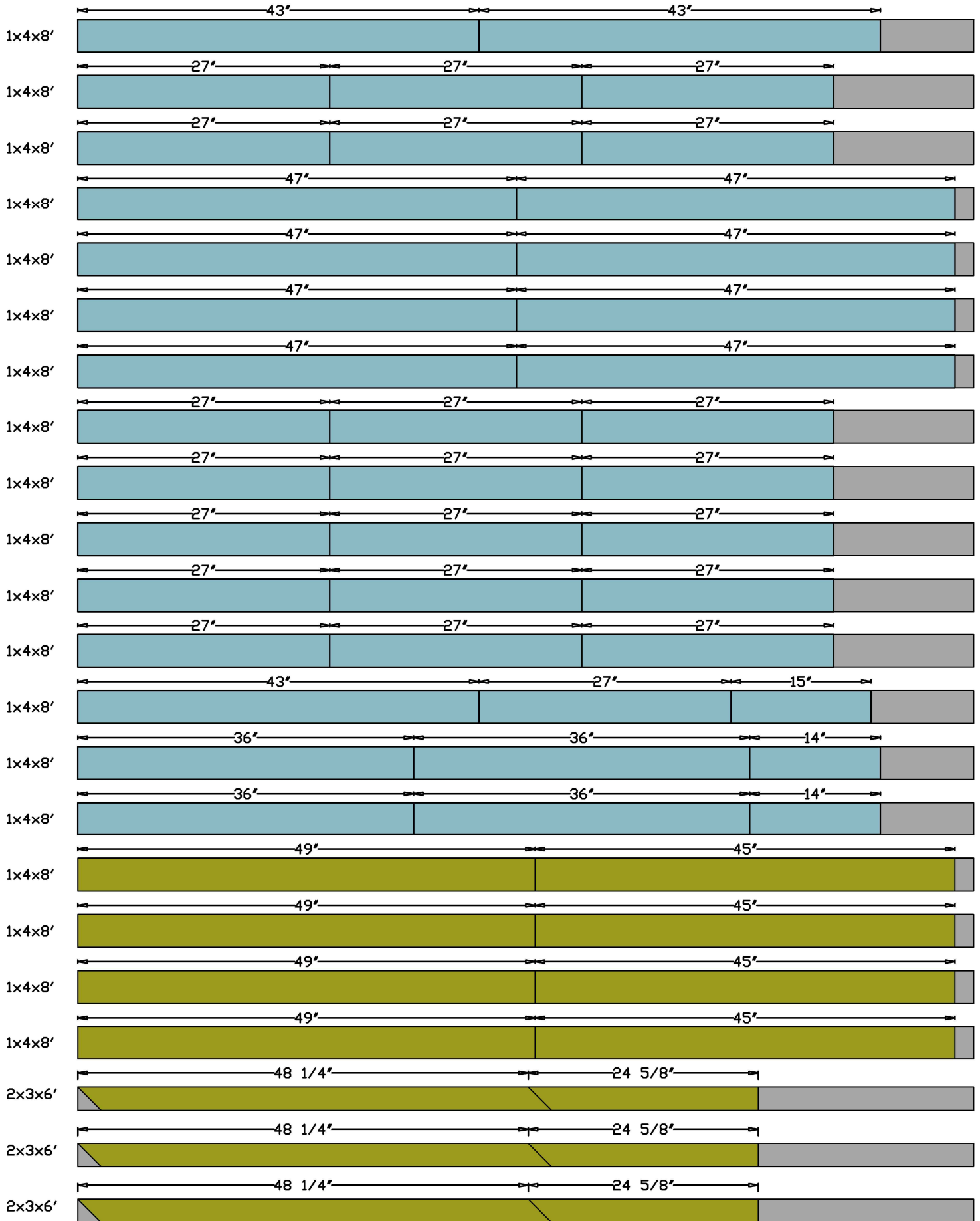

# Cut List

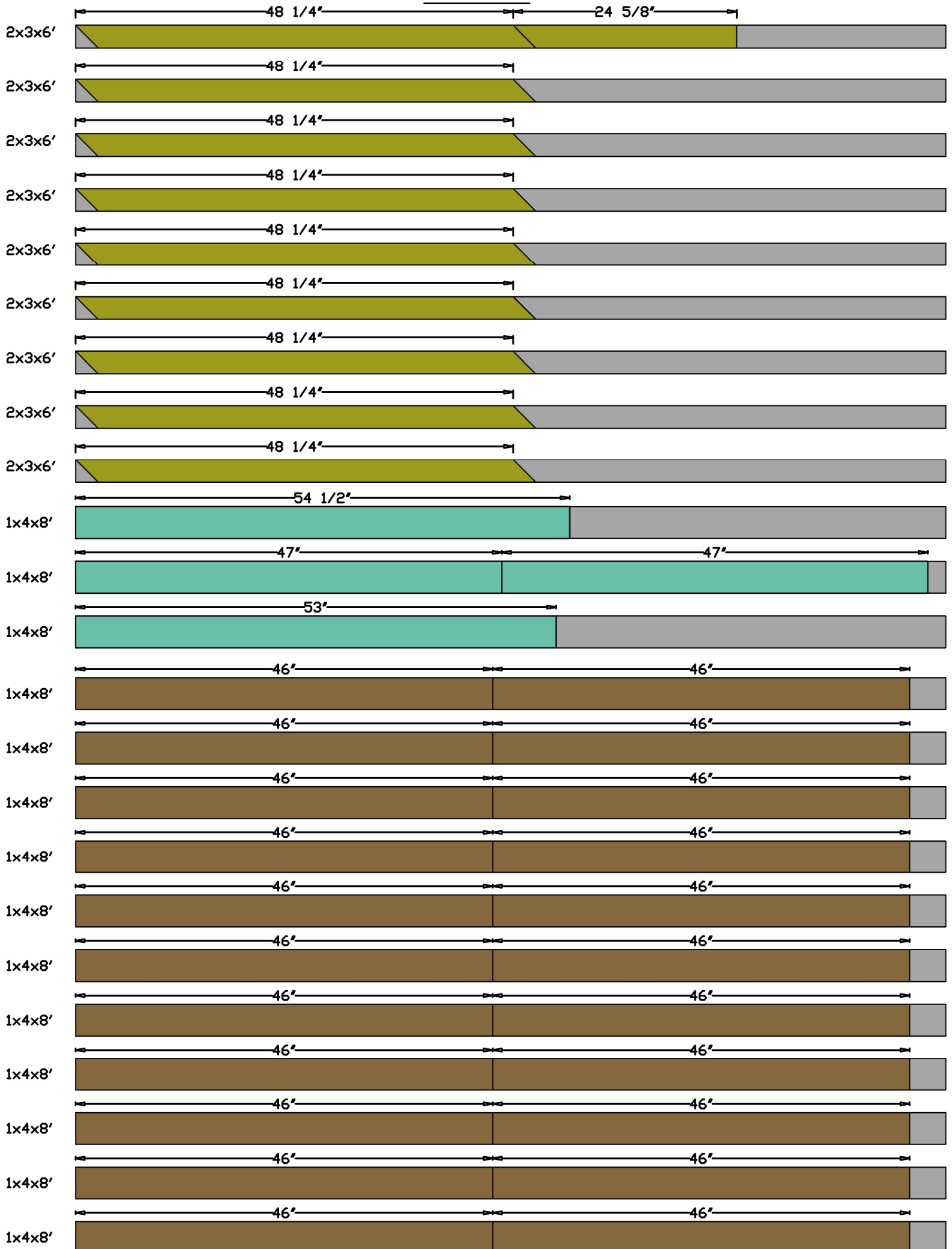

# Cut List

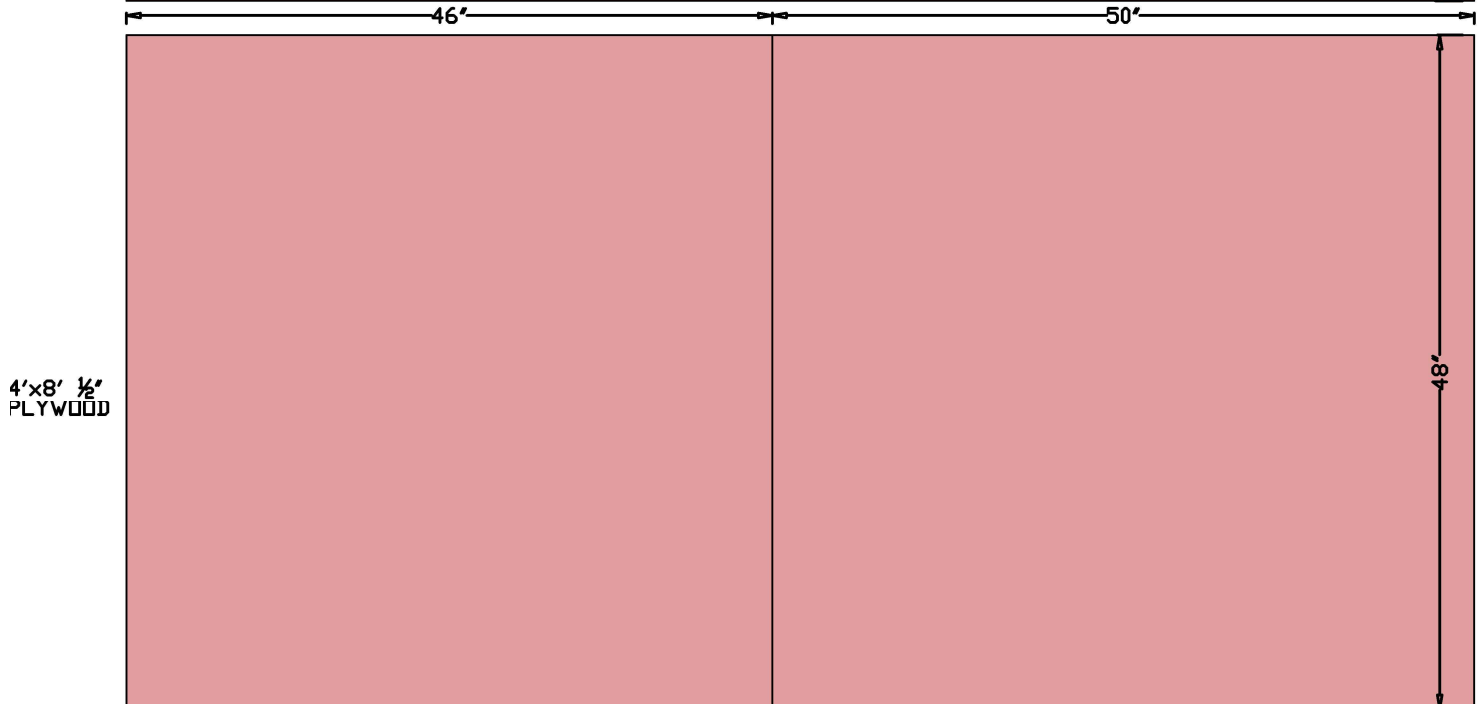
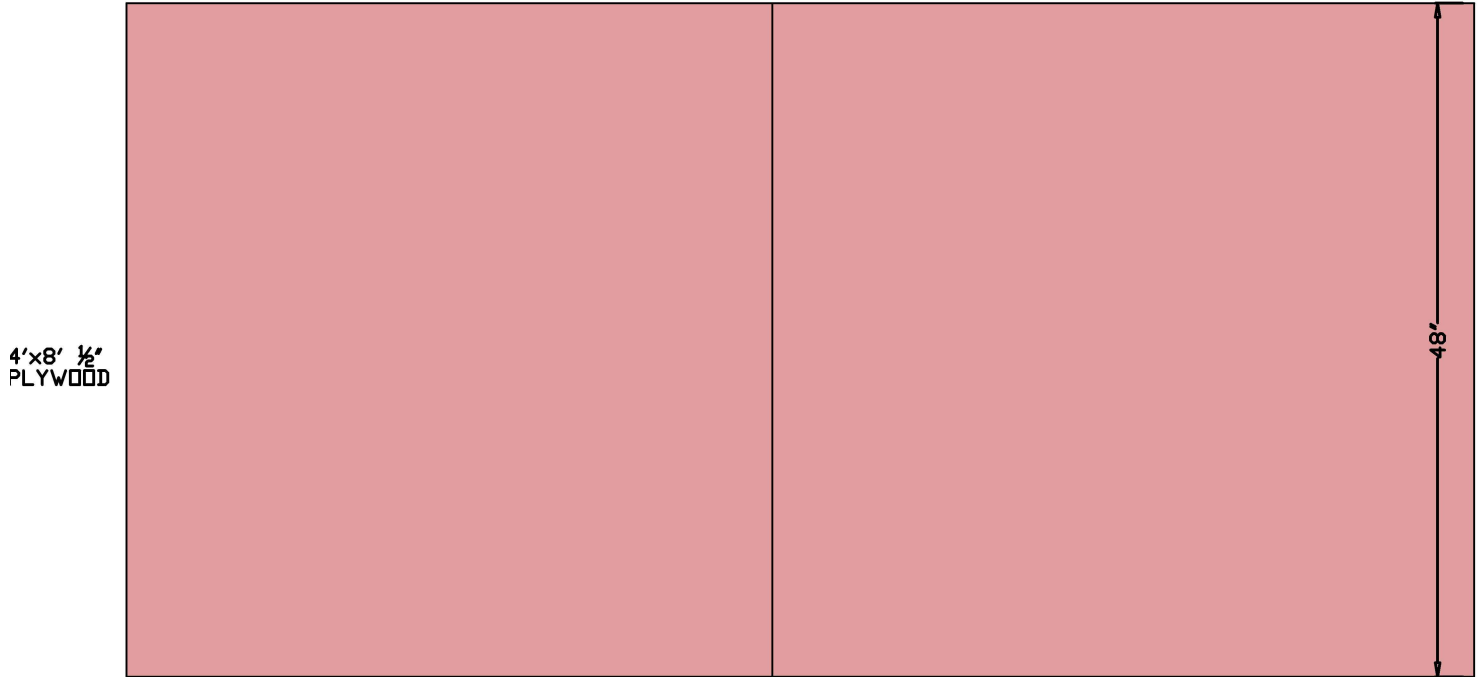
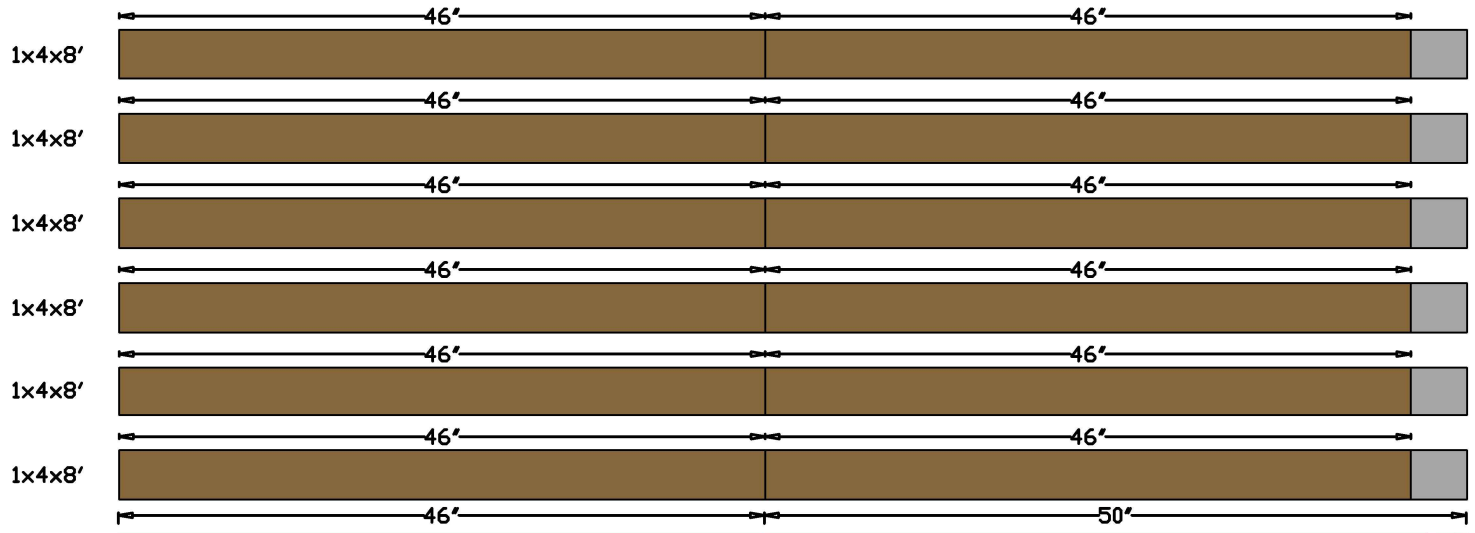



## Step 1

Layout the locations for the main posts per provided drawing. Dig the holes using a hole digger. The holes in the ground need to be 2 feet deep and wide enough to insert 8" round concrete form tube. There will be 6 posts for the main playground, 2 posts for the bench, and 2 posts for the swing

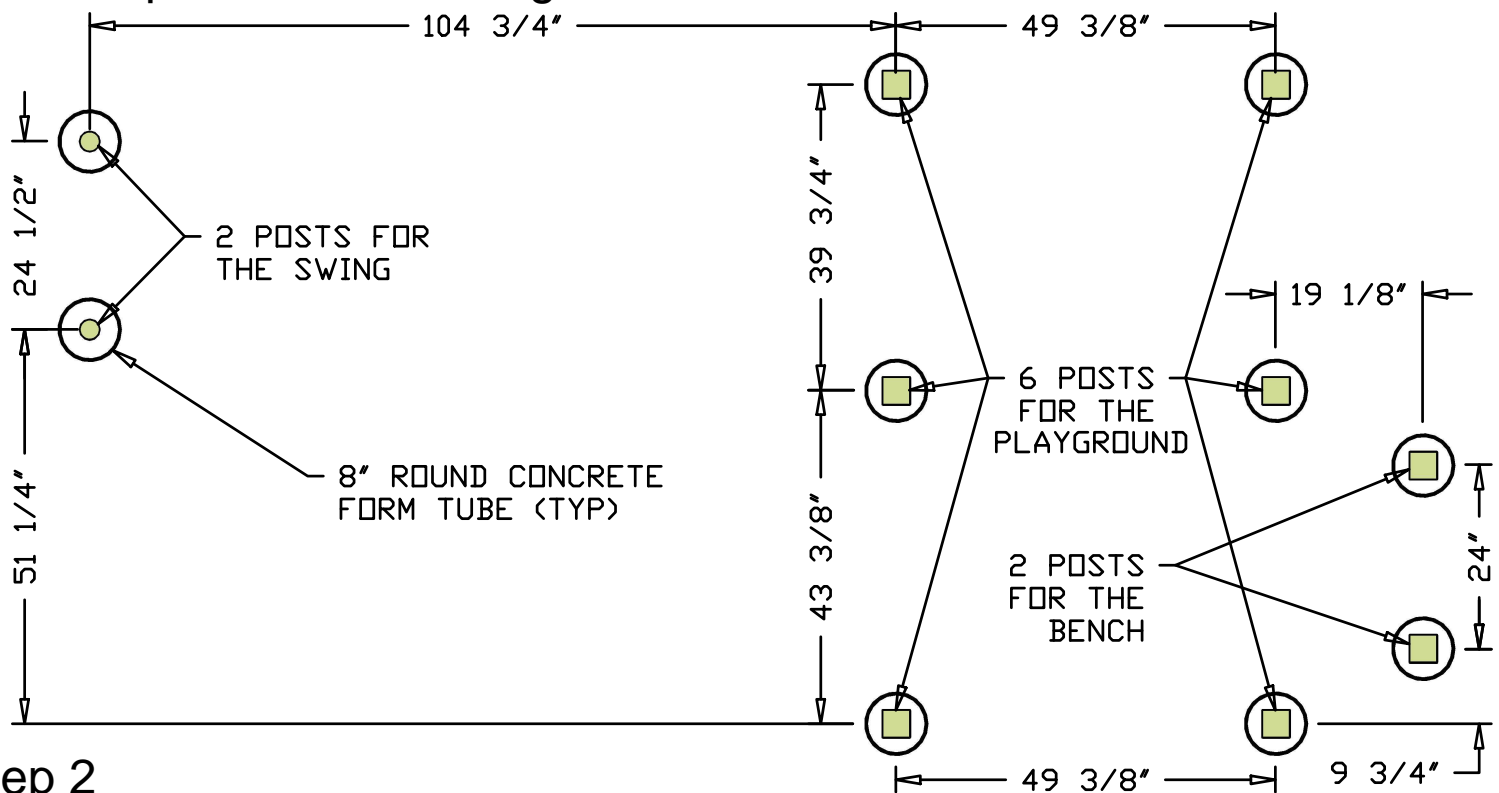

## Step 2

After all of the holes are dug and form tubes are in place. Insert 10 feet long pressure treated 4x4s inside the form tubes for the playground supports. I used 2 1/2" round metal pipe for the two swings posts. Mix and pour the concrete inside the form tubes making sure all posts are plumb using a level.

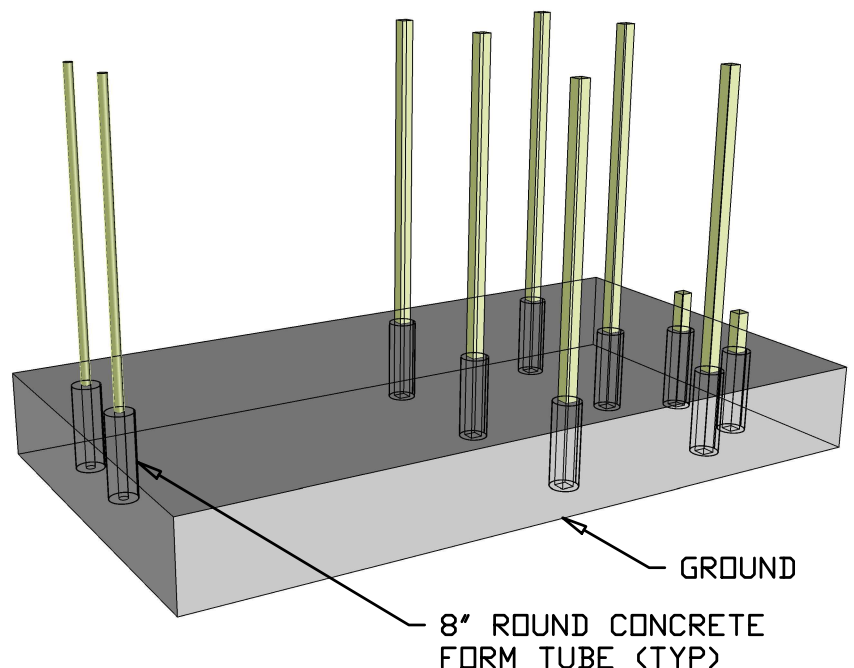

### Step 3

2 ½" METAL PIPE  
87" TALL (X2)

Once the concrete completely dries, using a skill saw, cut the posts to the provided height dimensions. These dimensions are from the ground up. The additional two feet are underground.

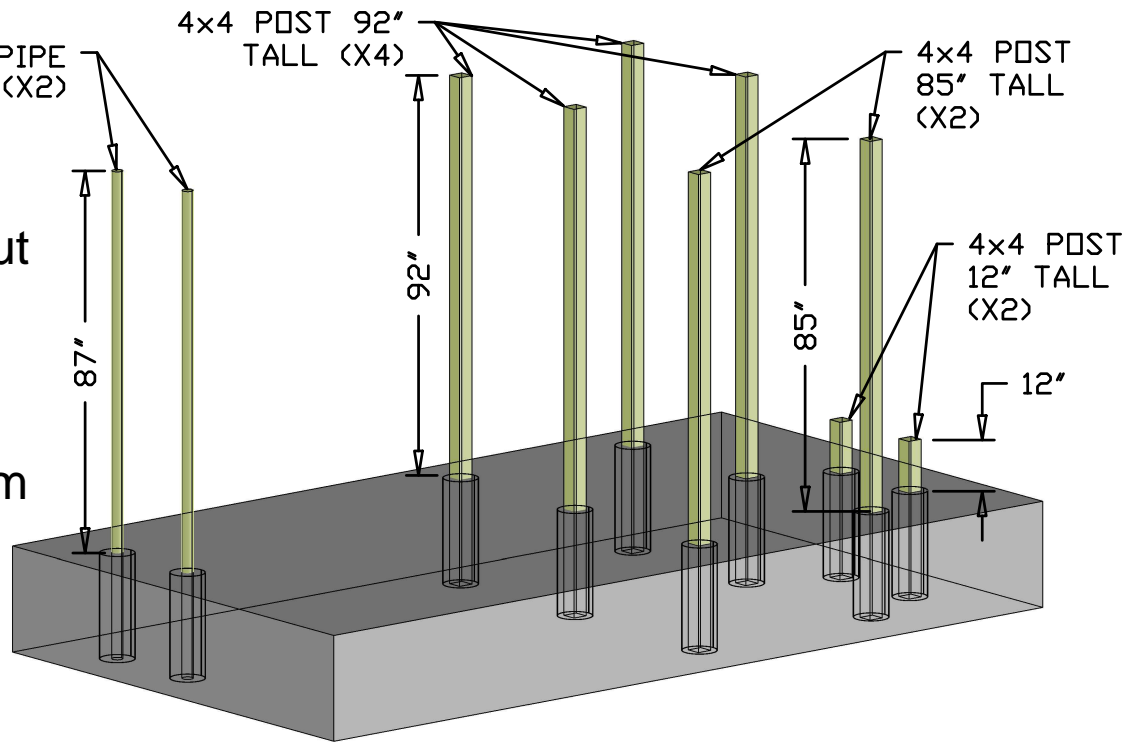

### Step 4

Working from ground up, make sure to measure every piece before cutting for accuracy. Just in case if your posts shifted slightly during concrete pour, your measurement might be somewhat different from what's on the picture. Use deck screws to fasten 2x4s and 1x4s to posts.

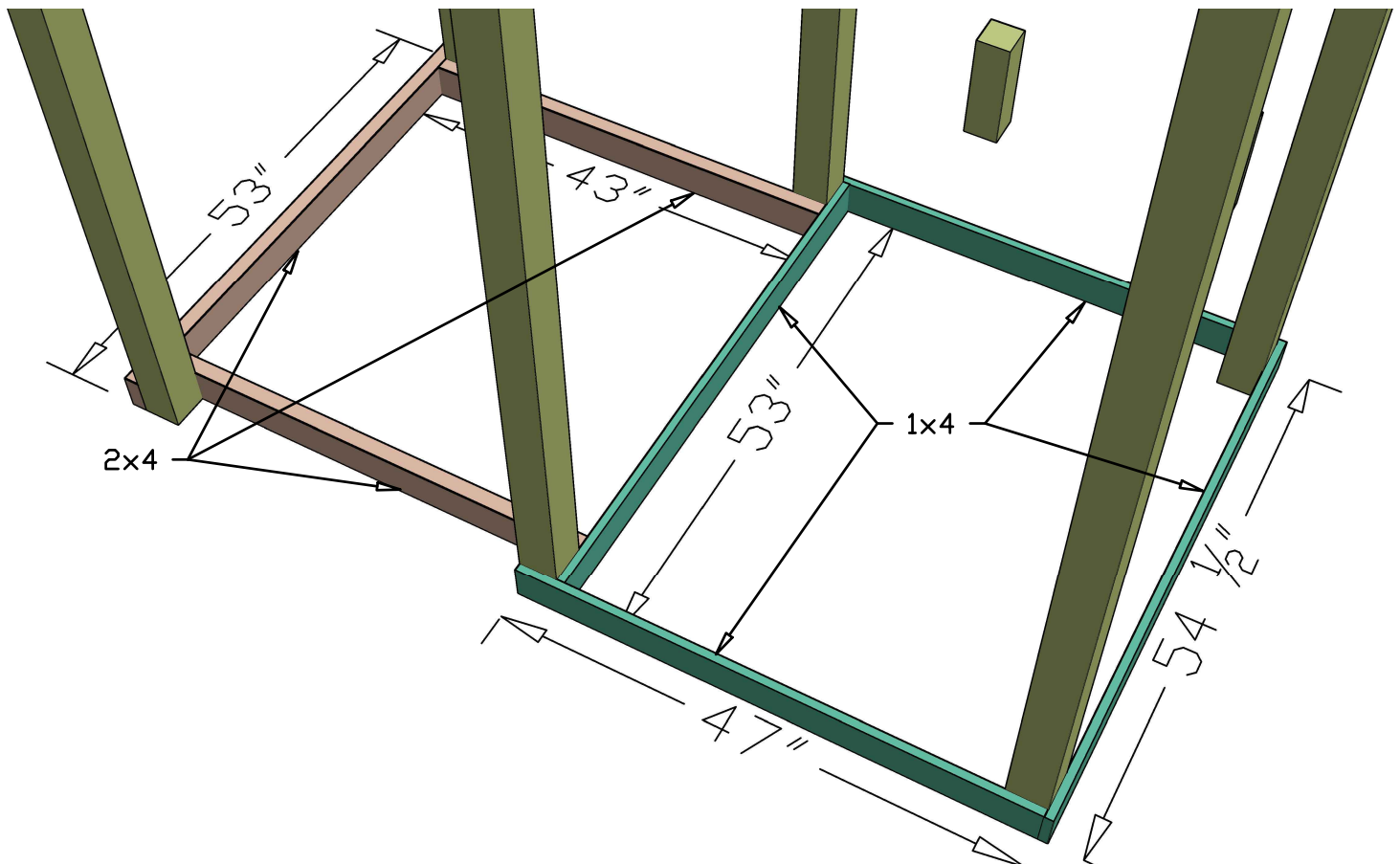

## Step 5

The area with 2x4s supports will be covered with 1x4s to make a ground floor. Measure and cut 1x4s, then spread them out evenly with 1/2" between each board. Attach using 1 1/2" deck screws.

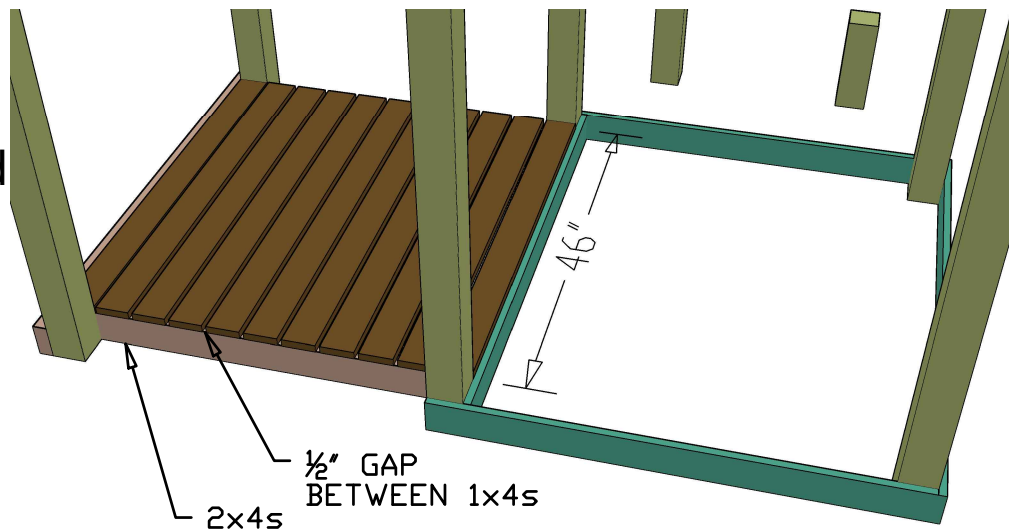

## Step 6

The second floor supports will be also built from 2x4s. The lower deck is 44" from the ground and the upper deck is 54 1/2" from ground.

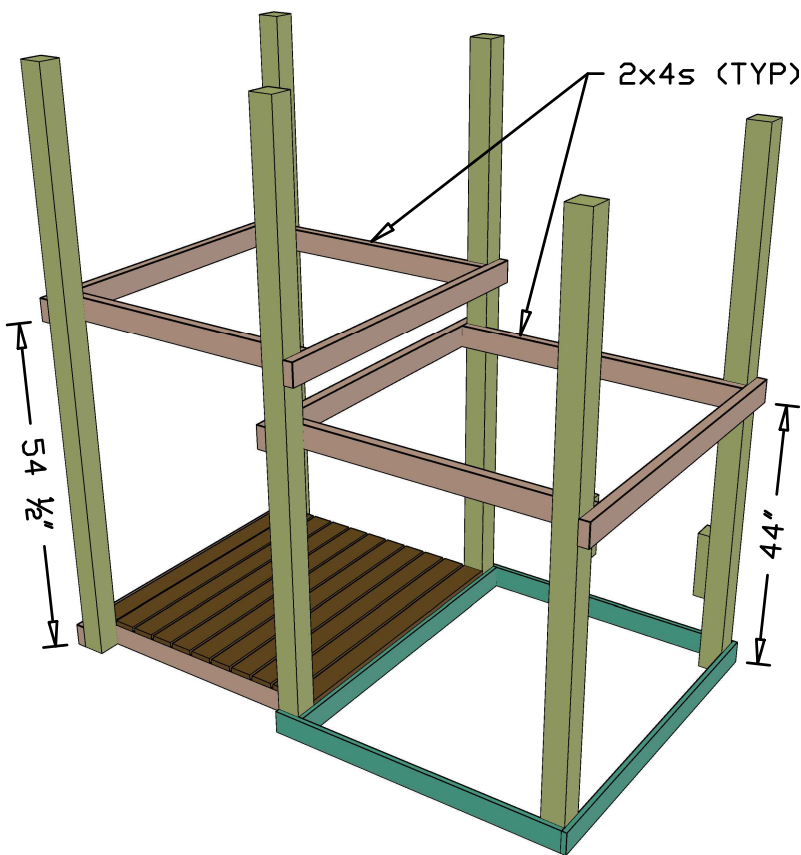

## Step 7

Similar to step 5, use 1x4s to build the upper and lower deck. Make sure to have 1/2" gap between the boards.

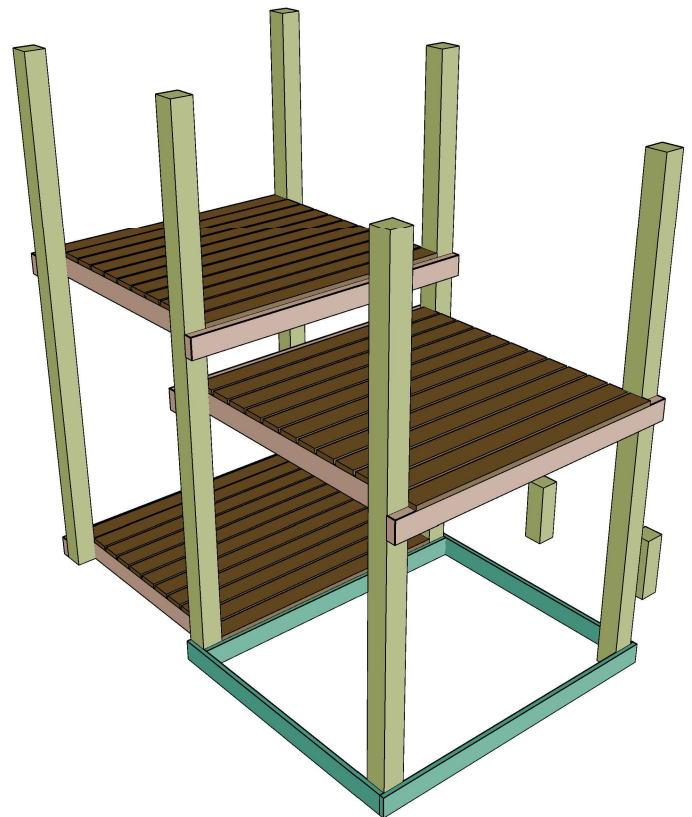



## Step 8

For this step, make a fence panels using 1x4s for both the rails and pickets. Measure the distance from post to post for rail dimensions, again your dimensions might be slightly different than what's on the drawing. Make 2" gap between pickets. Use 1 1/2" deck screws to attach the boards.

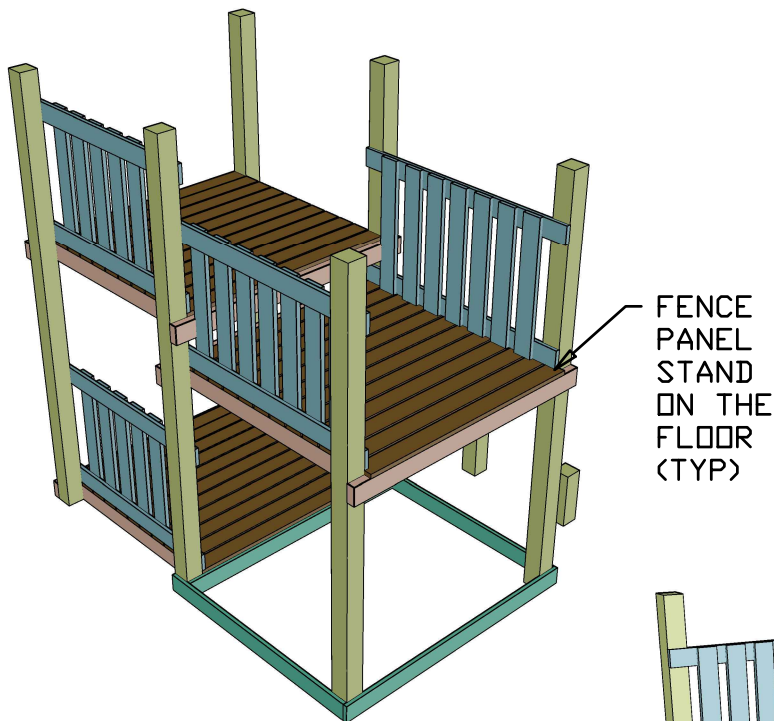
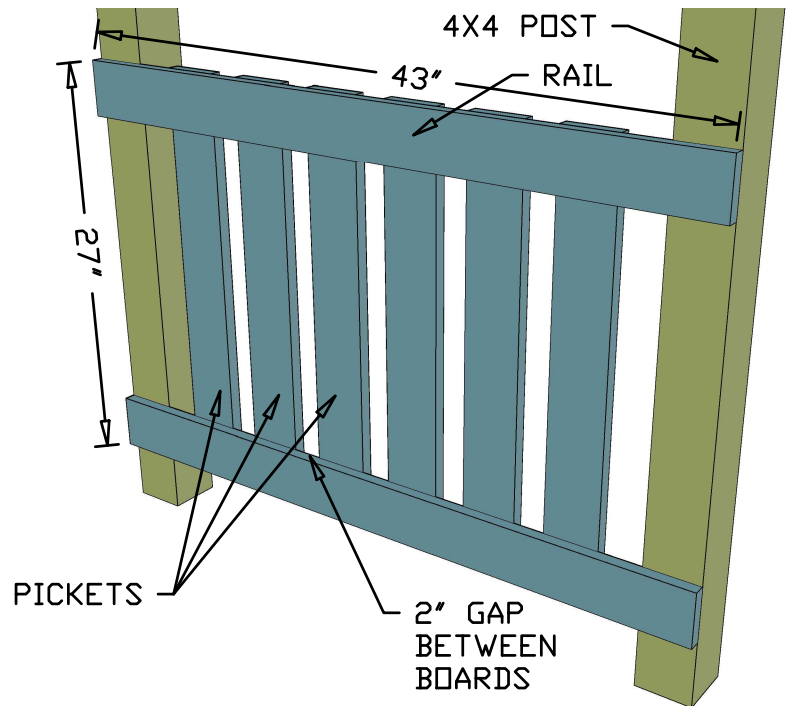

## Step 9

There will be 4 full fence panels. Place the panels on the floor and then attach them to the posts.

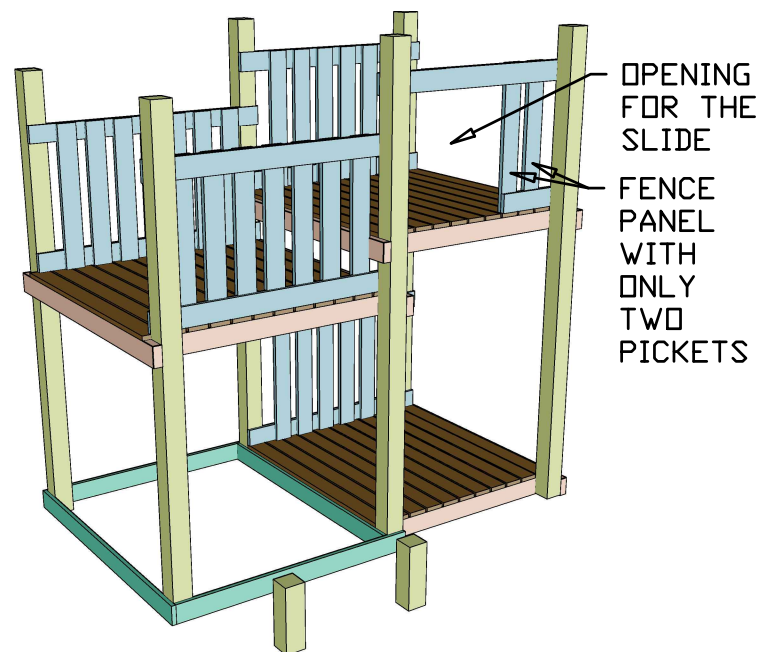

## Step 10

The area for the slide will have a partial fence section with only two 1x4 pickets.

### Step 11

Attach 70" long 2x4s at the very top of the posts. These are supports for roof trusses.

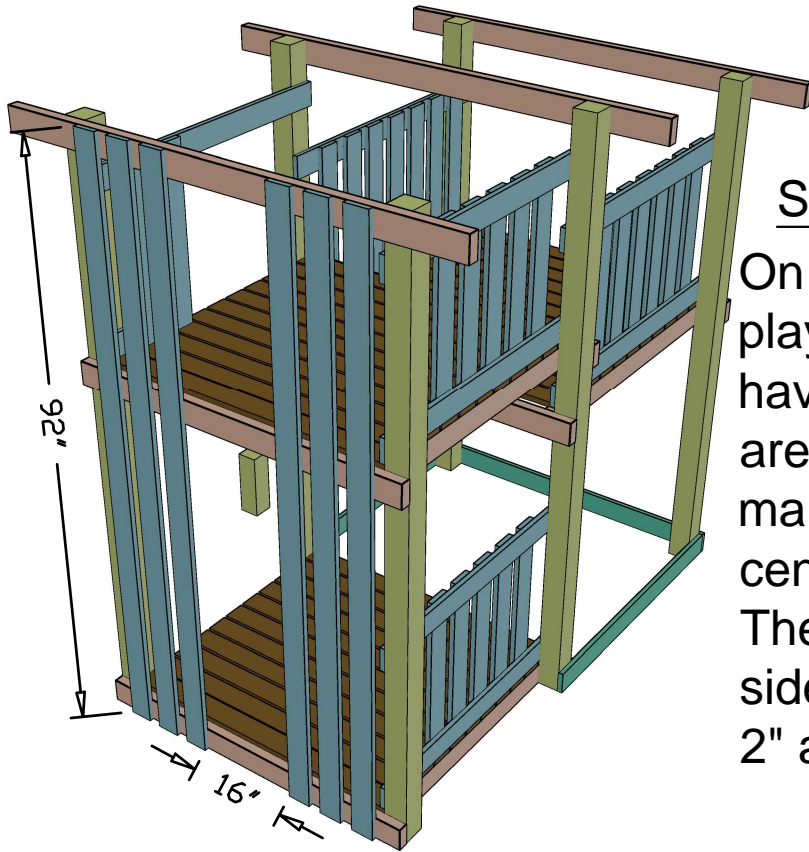
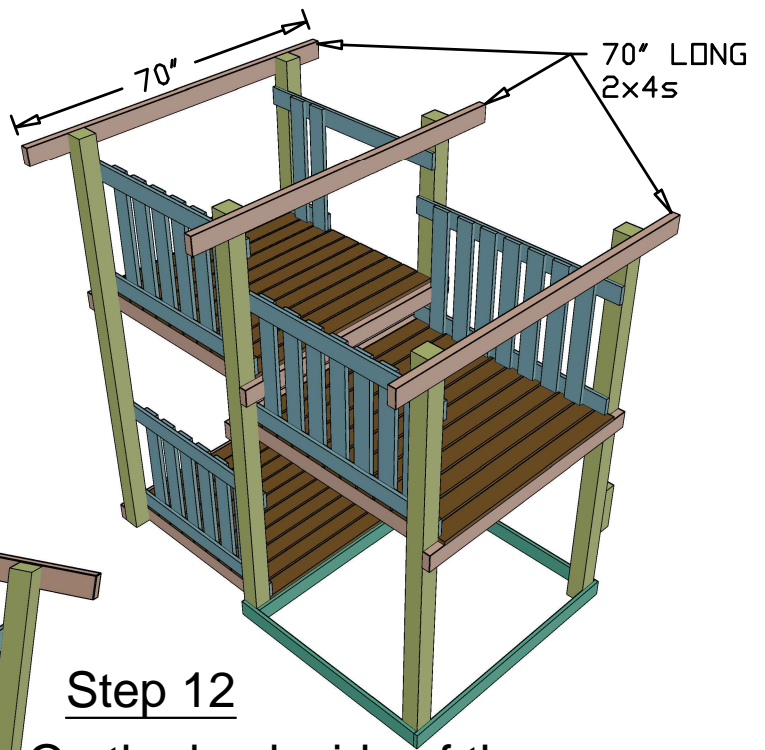

### Step 12

On the back side of the playground, in the center we'll have a half round rock climbing area that's 16" in diameter. So mark 16" wide section in the center for the rock climbing piece. Then attach 92" long 1x4s on each side of the 16" gap. The 1x4s are 2" apart.

### Step 13

Now attach the rock climbing piece and the handles.

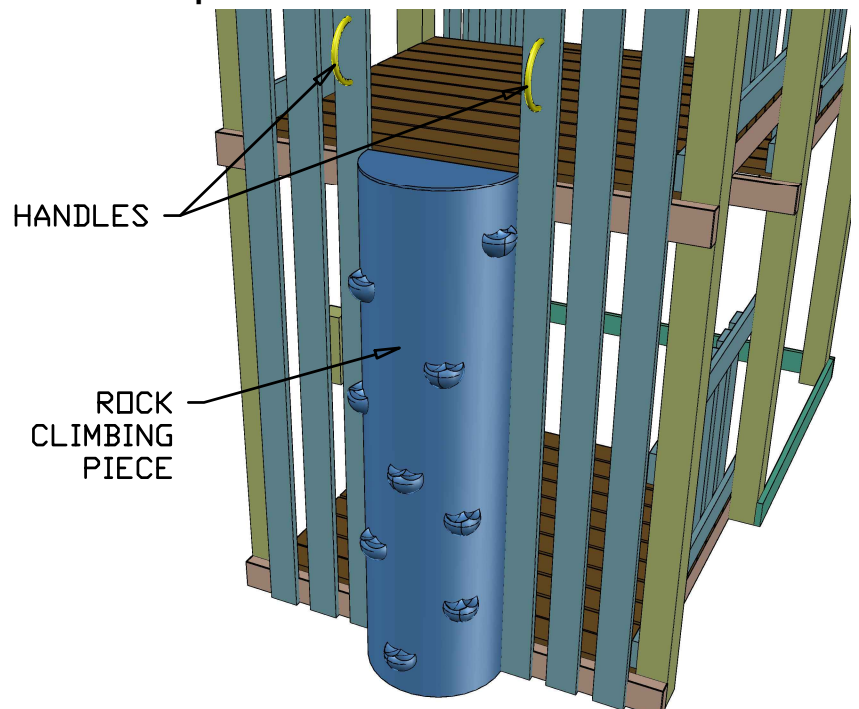

## Step 14

The front of the playground will also have a partial fencing. Attach 14" long 1x4 to the post at the bottom. Then attach two 36" long pickets on each side having 2" gap between each picket.

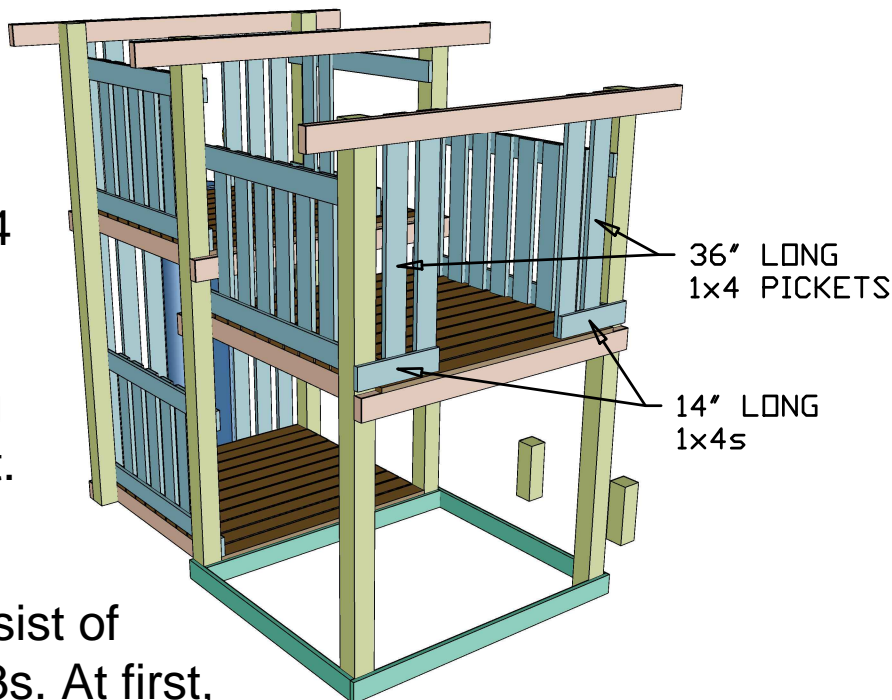

## Step 15

Building a roof truss will consist of combination of 1x4s and 2x3s. At first, build the left side of the truss separately from the right side. The top and bottom fascia boards are 45" long 1x4s. The 2x3 truss boards are cut at 45° and 48 1/4" long. Attach all 3 truss boards to upper and lower fascia boards using 1 1/2" deck screw. Once both left and right trusses are complete, attach them together at the top.

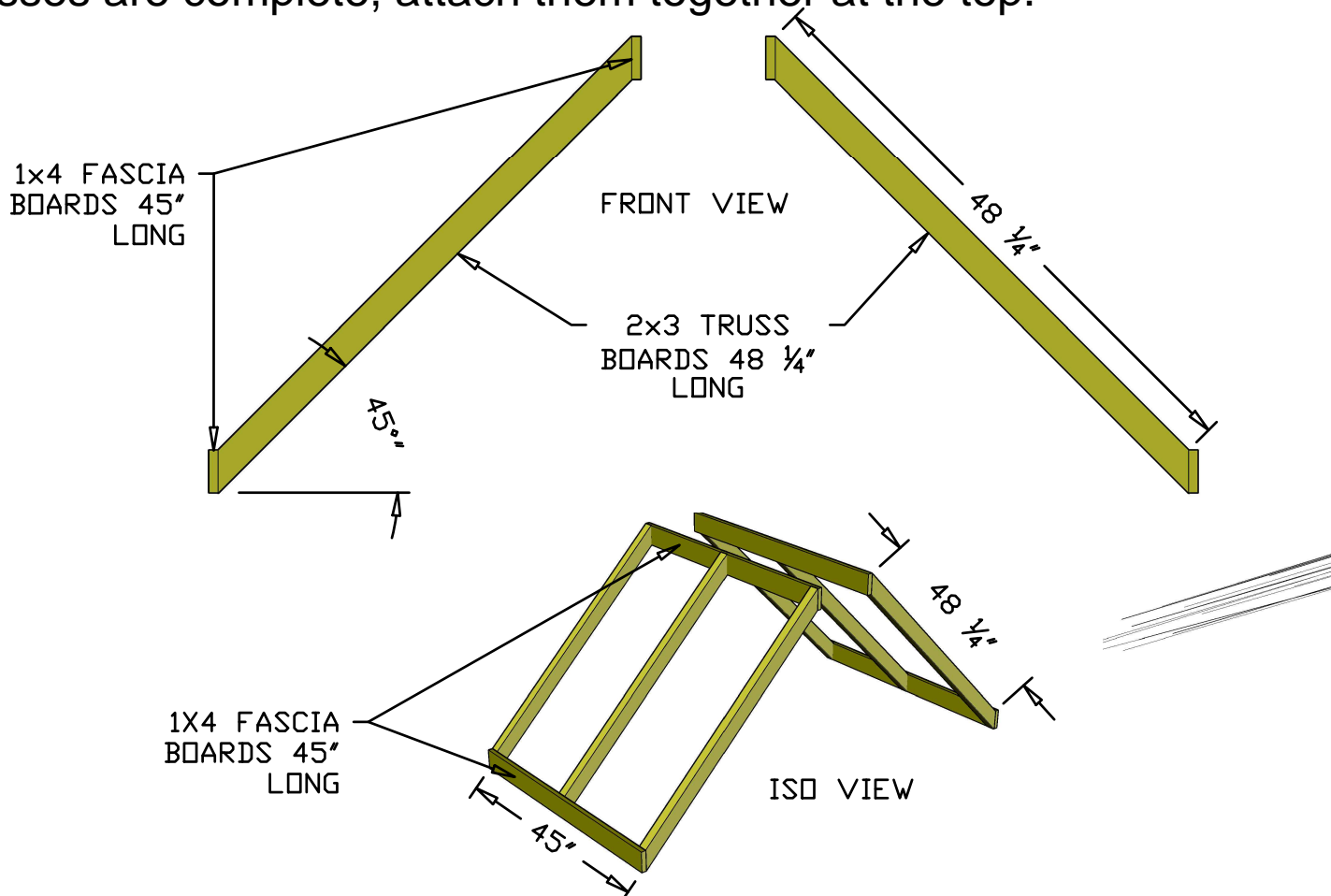



## Step 16

Now attach the entire roof framing to the 2x4 support that were previously installed. After roof frame is installed, cut 24 1/2" long 2x3 boars at 45° on one side and attach them at the front of the truss making a diamond shape design.

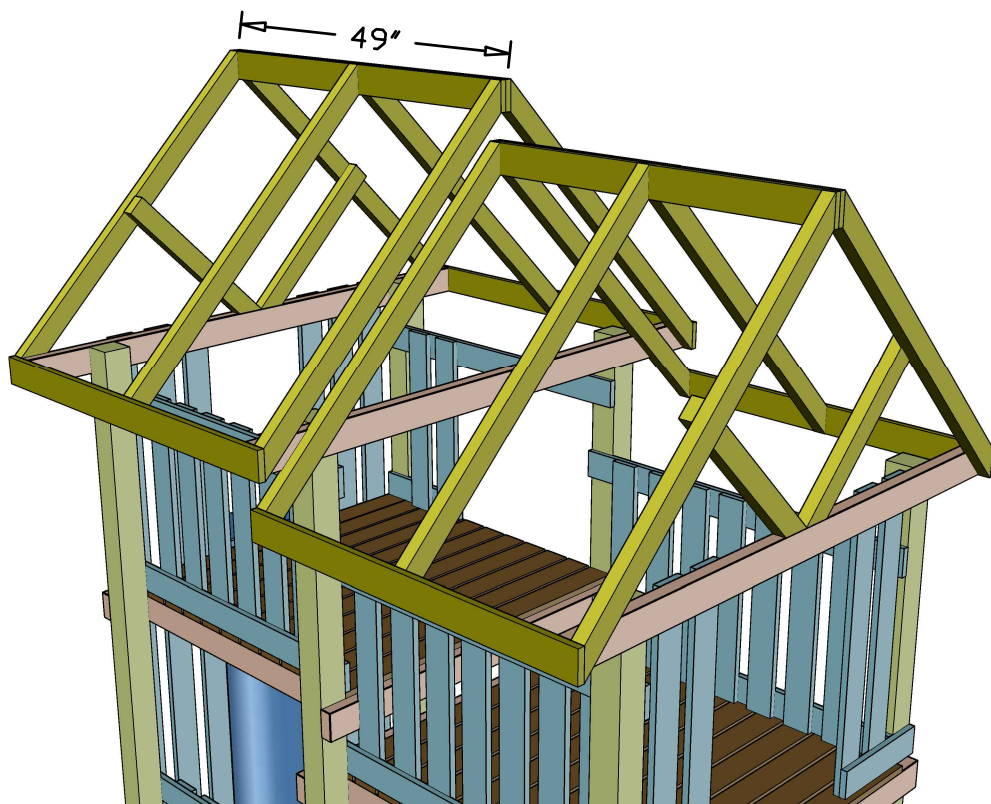
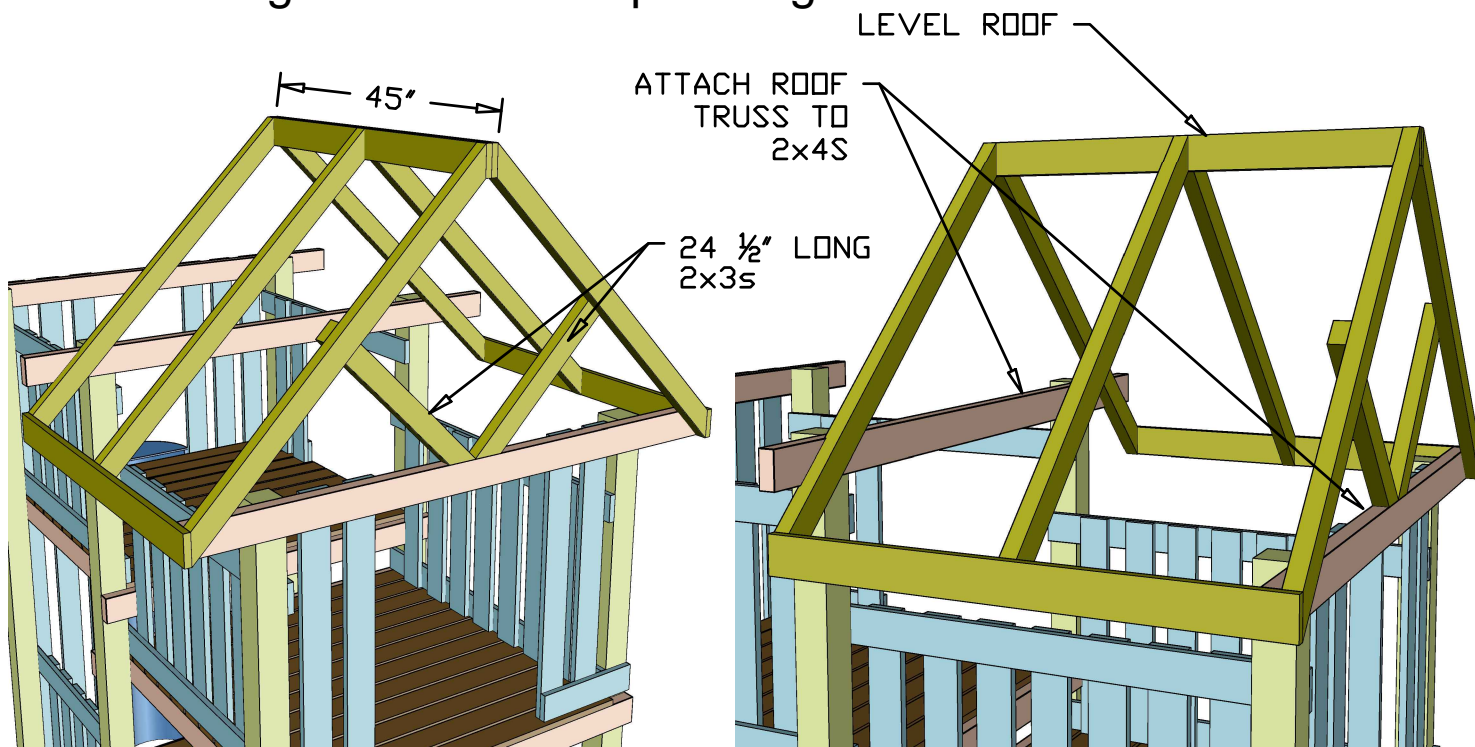

## Step 17

Similar to step 15, build a second roof but now its 49" long. Attach the roof trusses to 2x4 supports.

## Step 18

Cover the roof framing with 1/2" plywood. Then cover the plywood with shingles.

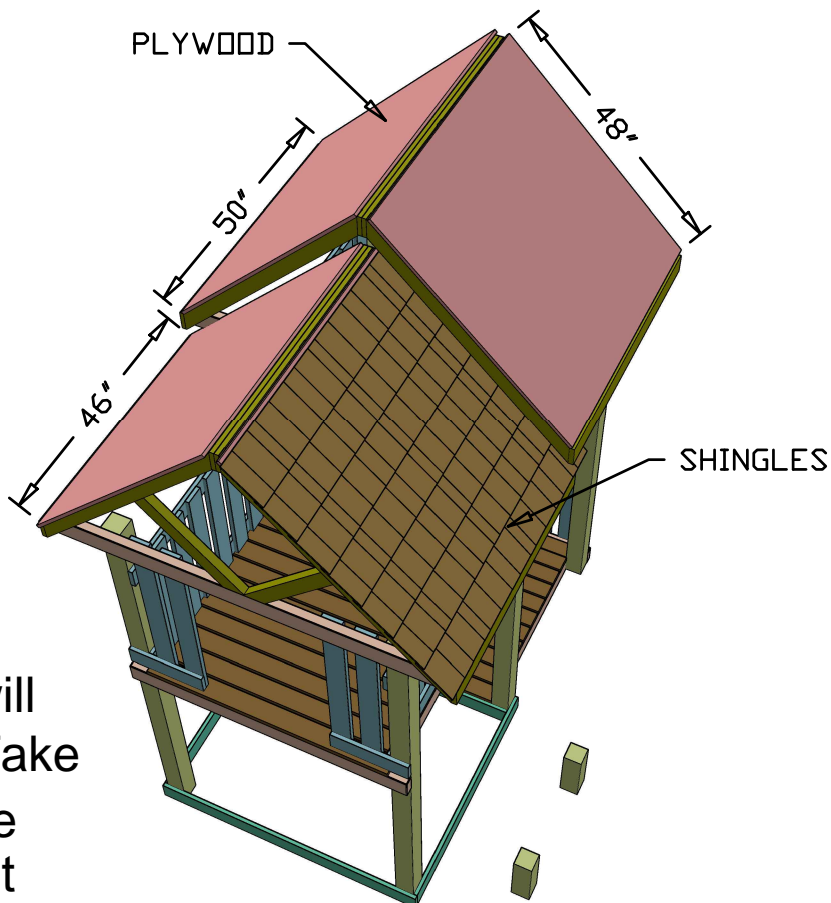

## Step 19

The front of the playground will have a ladder in the center. Take 2x4 and cut to 52 1/8" (x2). The bottom is cut at 69° and top at 21°, see picture. Cut 18" long steps from 2x4s (x4) working from bottom up, the first step is 10" from bottom, the rest are 12" apart. Attach the ladder using 2 1/2" deck screws to front 2x4. Fasten handles for ladder.

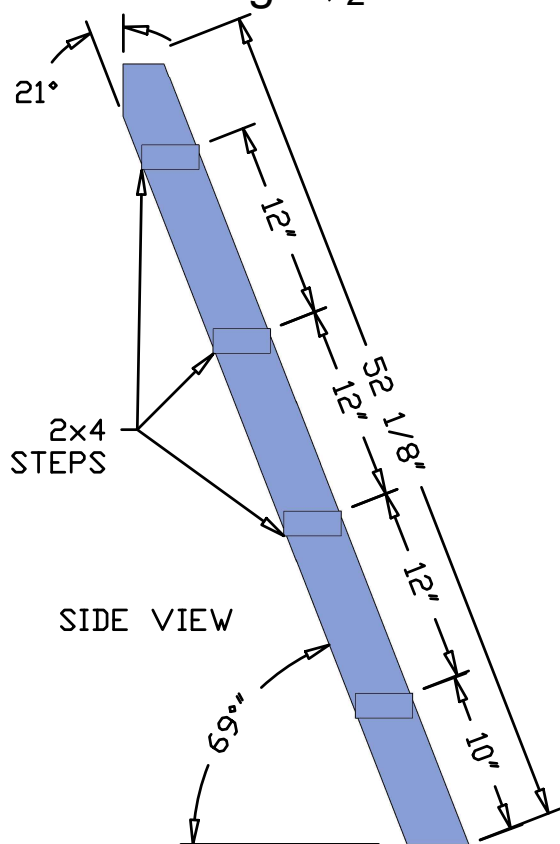

## Step 20

For this step build a bench and a table. Take 2x4 and cut it to 16" with one side at 45° (x2). Also, cut 2x4 to 17 1/2" long with both sides at 45° (x2). Build a triangle as shown on the picture and attach it to the 4x4 post at 23 3/4" from the ground. Once the supports for the table are fastened, cut 1x6 to 47" long (x2) and attached these board to table supports. The bench will also be 47" long but from one 2x6 board. Attach the board to the short 1 foot 4x4 posts.

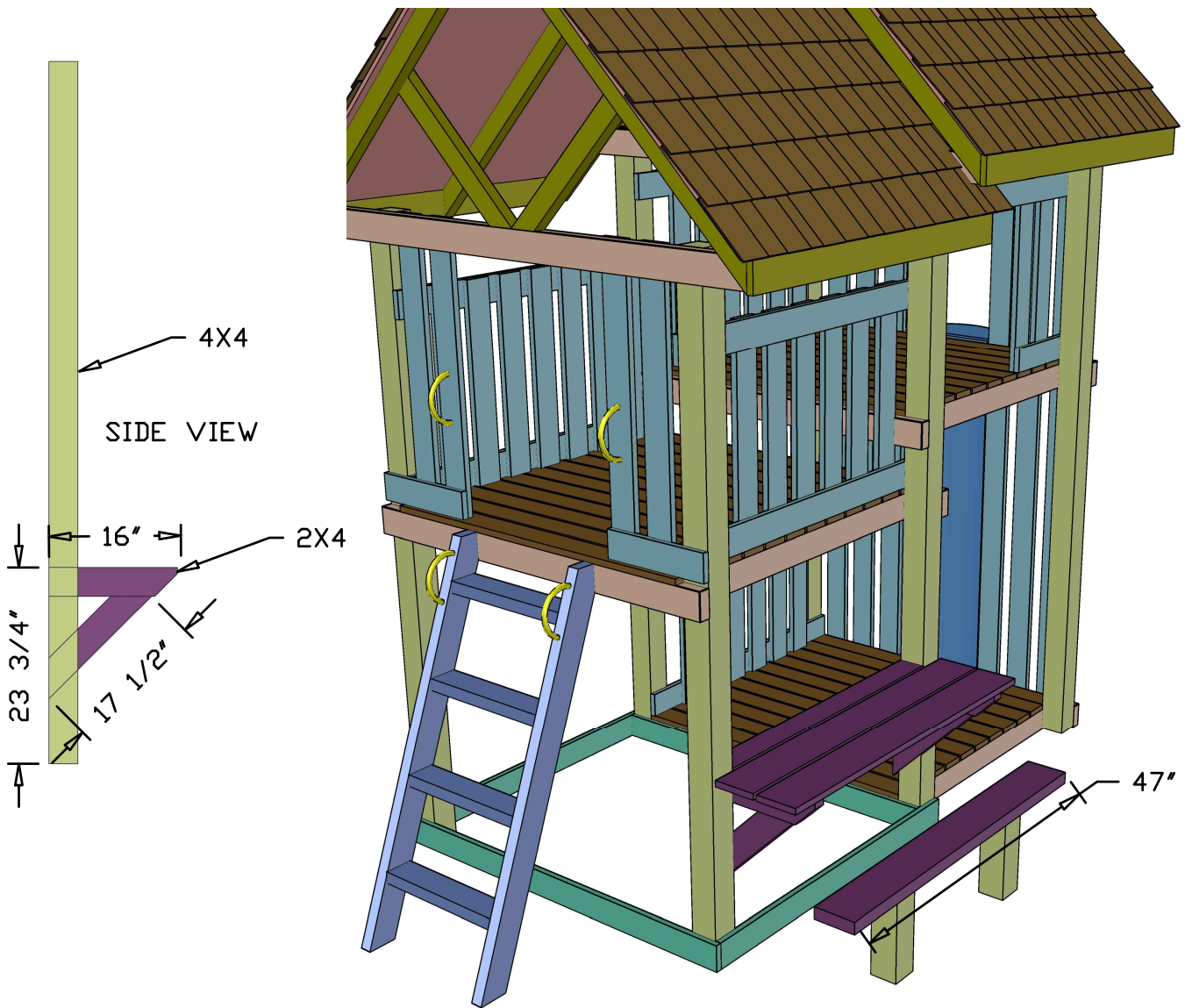



## Step 21

I used metal 1 1/2" x 4" c-channel for the horizontal support of the swing. You could use 4x4, but c-channels will last much longer than 4x4. C-channel will sit on a 2x4 that's attached to 4x4 posts. The other side of the c-channel will be placed on top of the round metal posts. Measure and cut the c-channel using a Sawzall with blade for metal cuts. Make sure the c-channels are leveled.

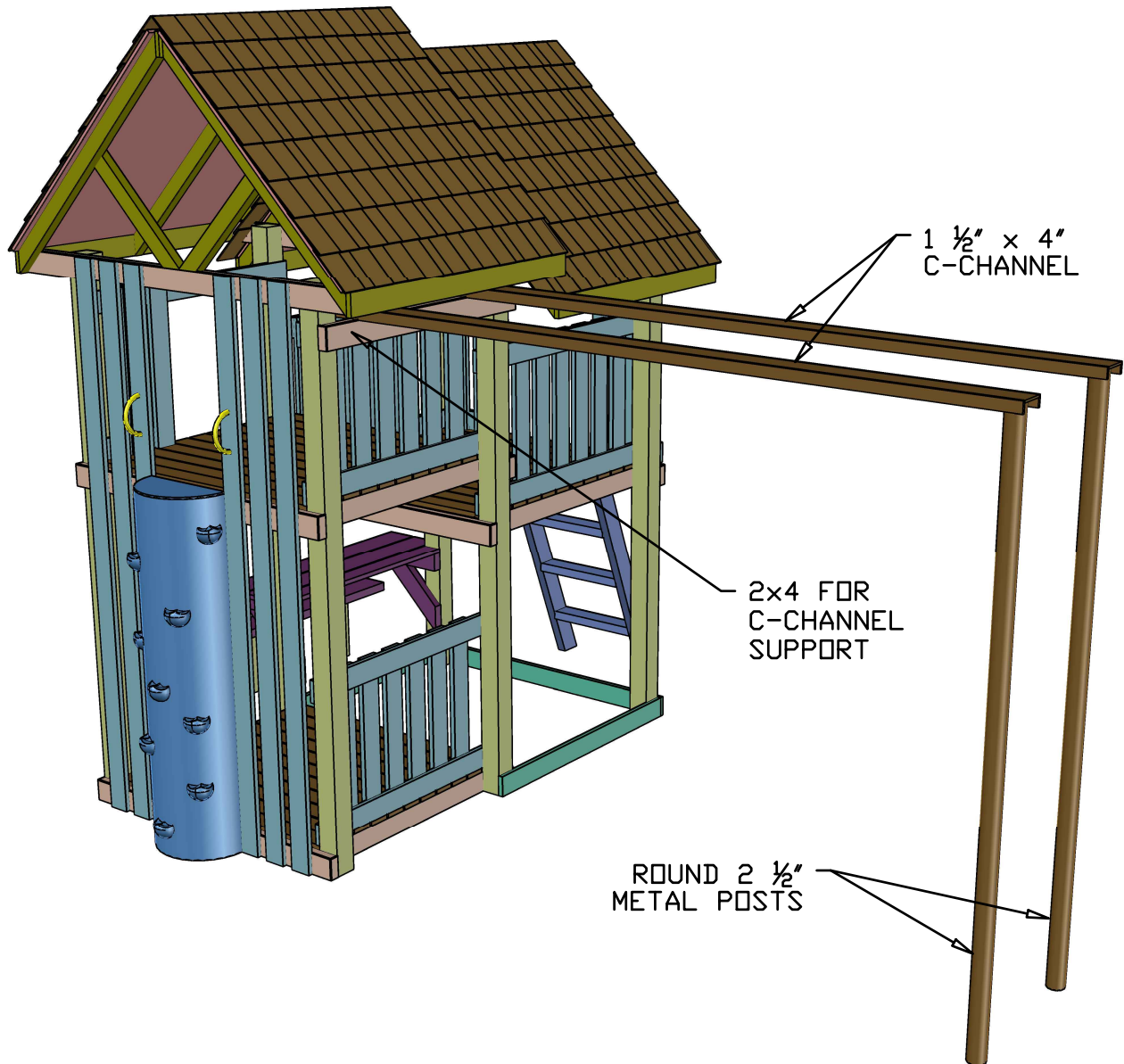

## Step 22

Attach the swing and a swing bar to the c-channel evenly spaced out. At the top of the round metal posts attach 1/8" thick flat metal bars making a cross. This will prevent the posts from moving when kids are using a swing.

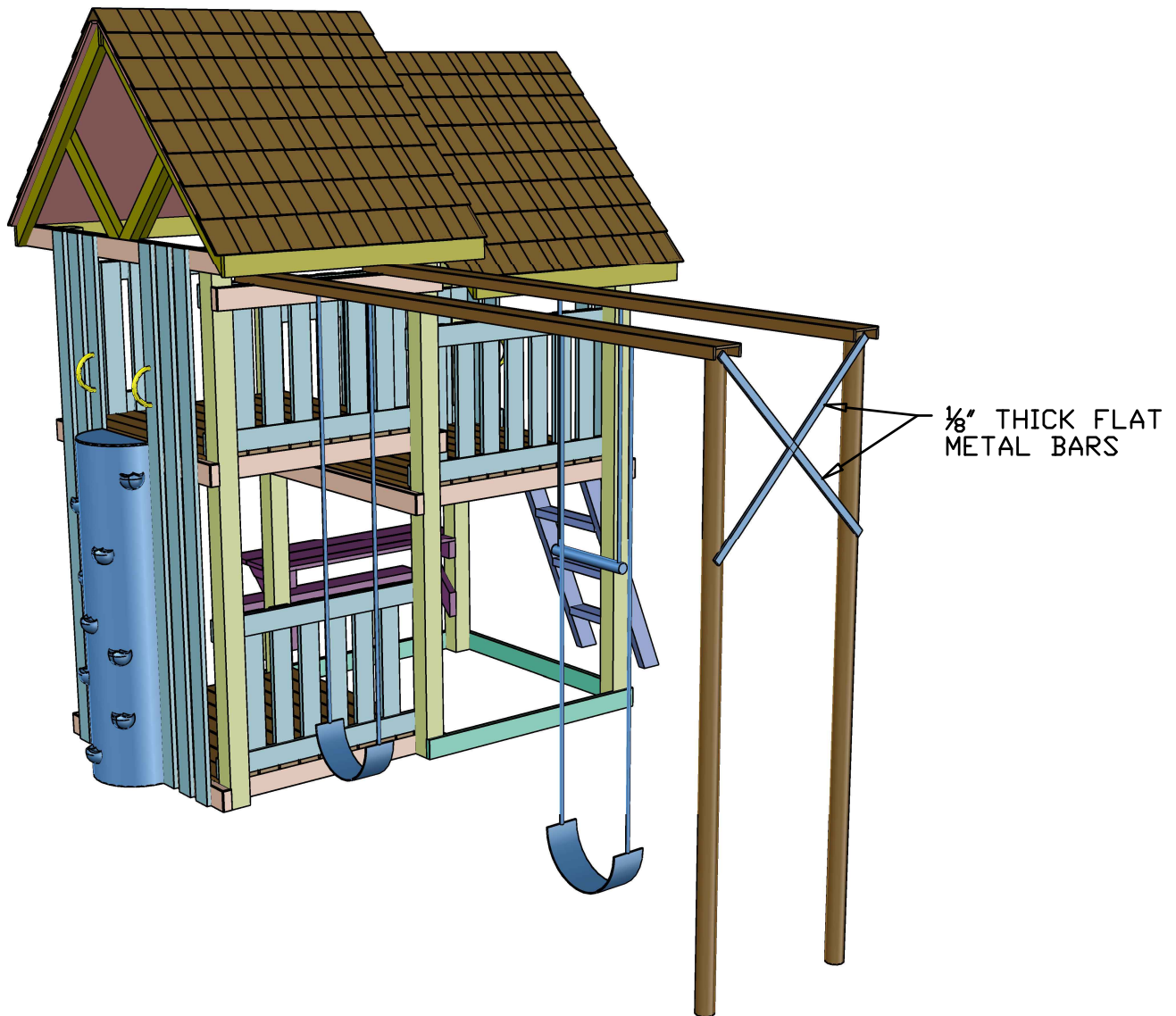

## Step 23

Finally attach the slide. You're done with the playground.

