

# הוראות הדפסה

## 3D PRINTING

Diza: 0.4 mm

Material: PETG

Number of walls: 4

Infill: 20

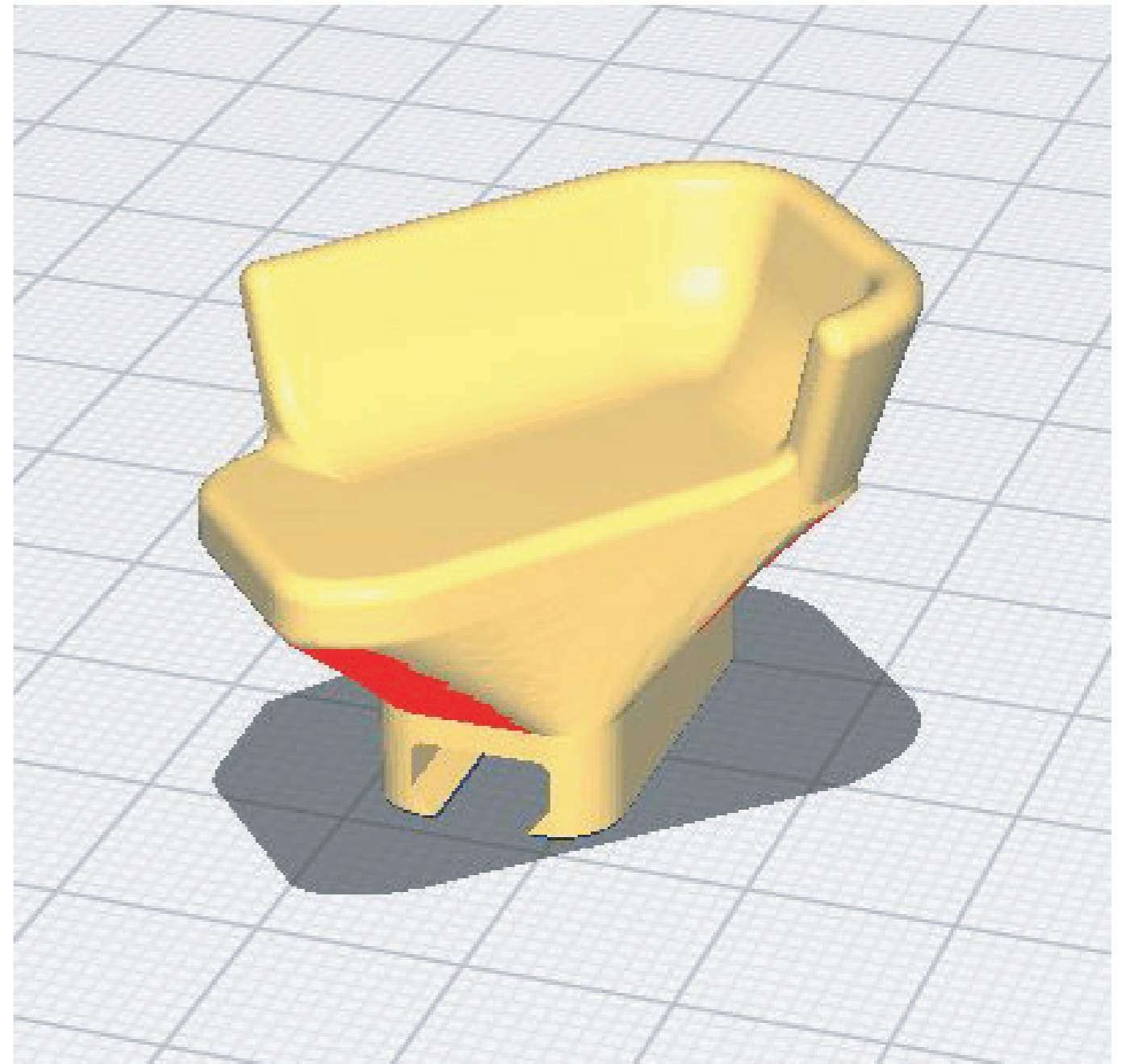

Positioning the model on  
the printing surface

# הוראות הדפסה

## 3D PRINTING

Diza: 0.4 mm

Material: PETG

Number of walls: 4

Infill: 20

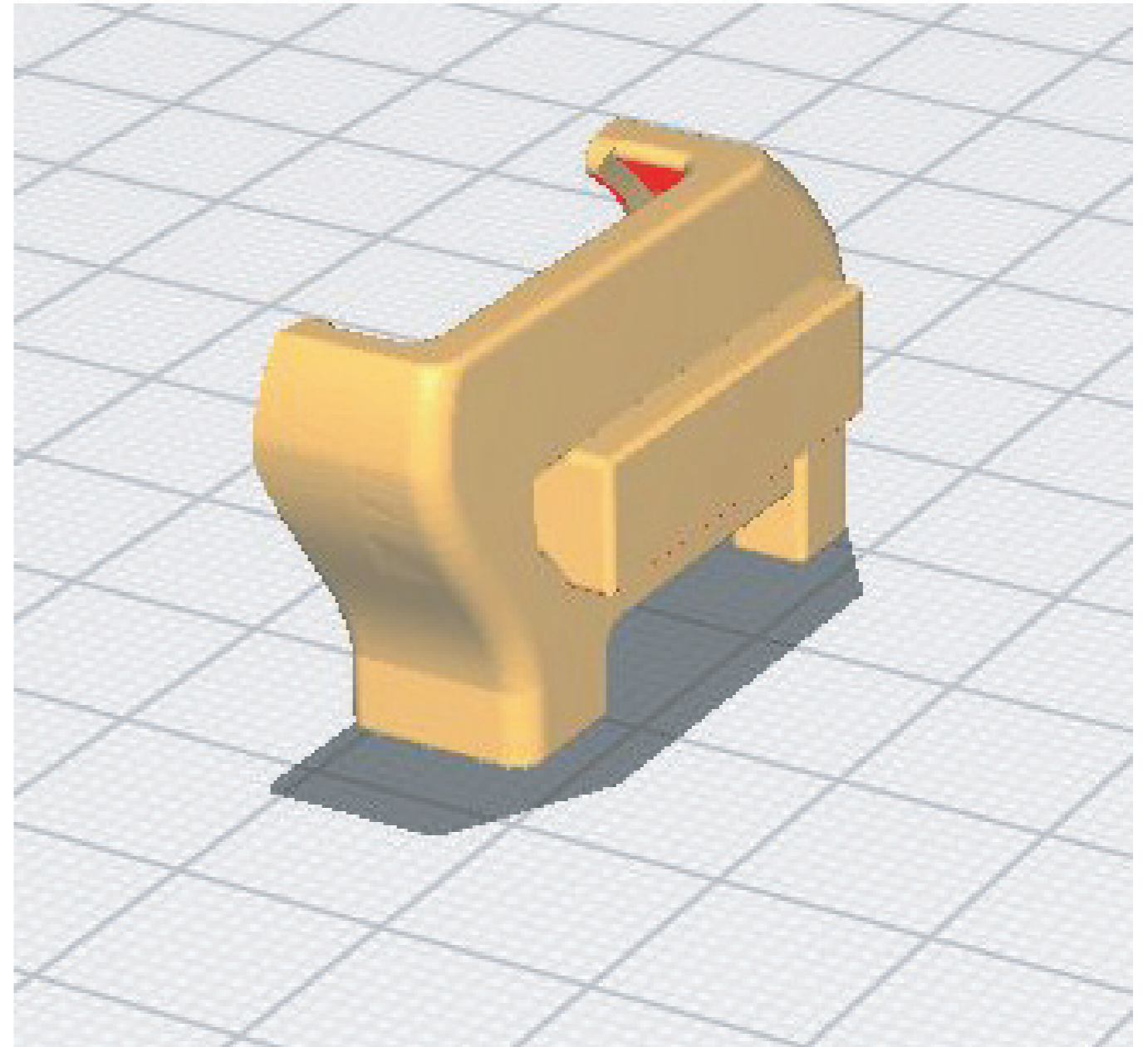

Positioning the model on  
the printing surface

# הוראות הדפסה

## 3D PRINTING

Diza: 0.4 mm

Material: PETG

Number of walls: 4

Infill: 20

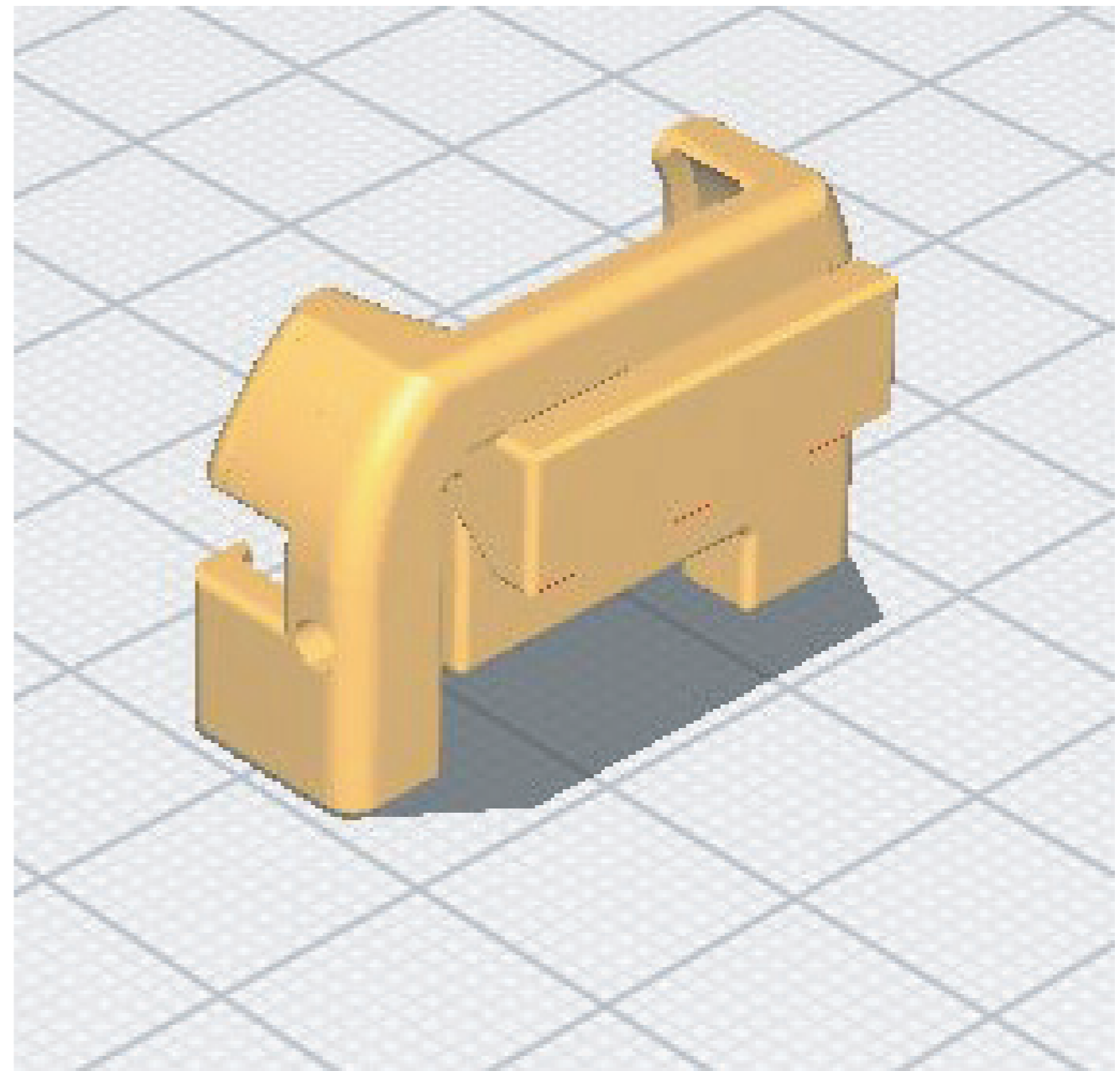

Positioning the model on  
the printing surface

# הוראות הדפסה

## 3D PRINTING

Diza: 0.4 mm

Material: PETG

Number of walls: 4

Infill: 20

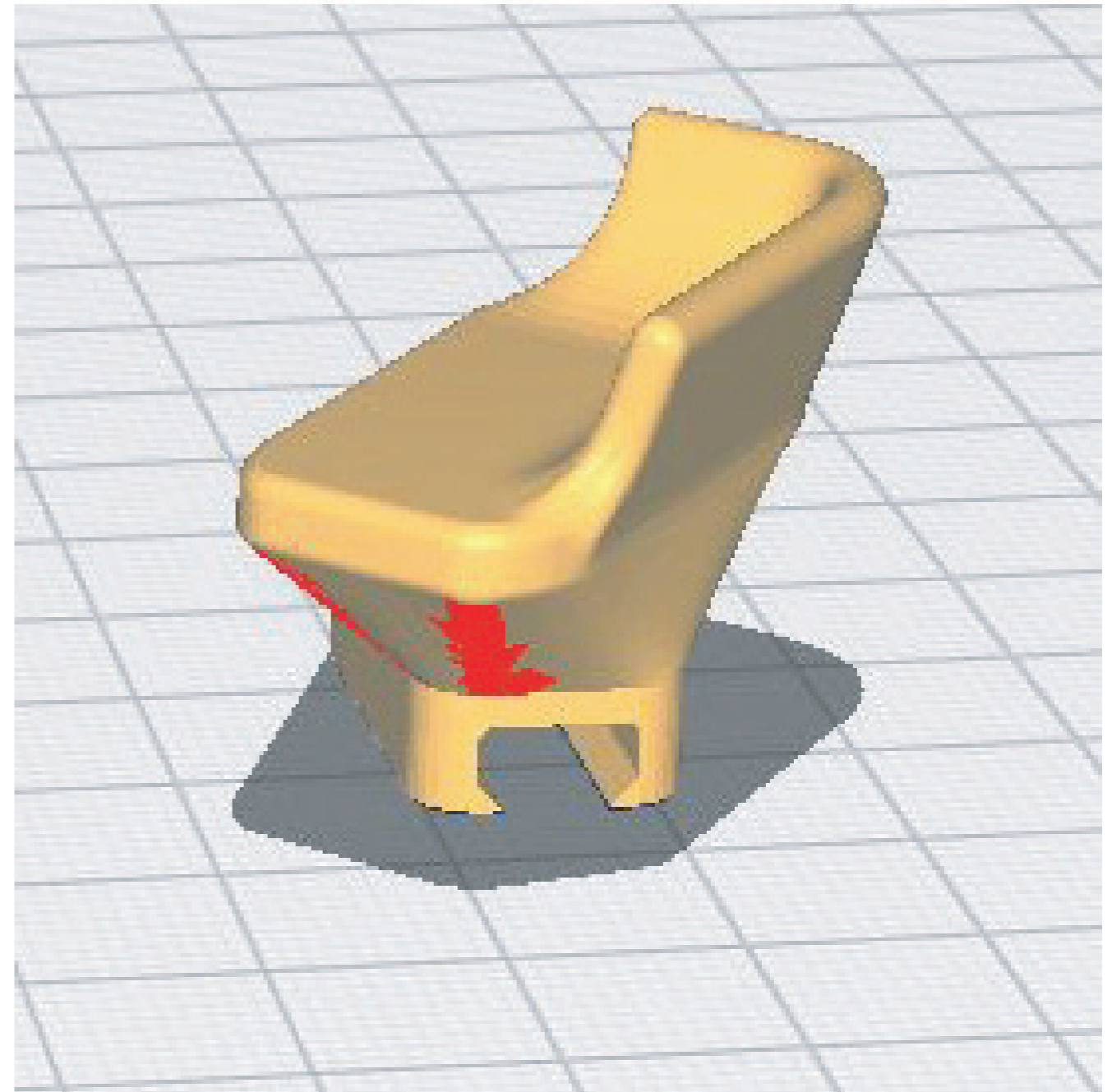

Positioning the model on  
the printing surface

# הוראות הדפסה

## 3D PRINTING

Diza: 0.4 mm

Material: PETG

Number of walls: 4

Infill: 20

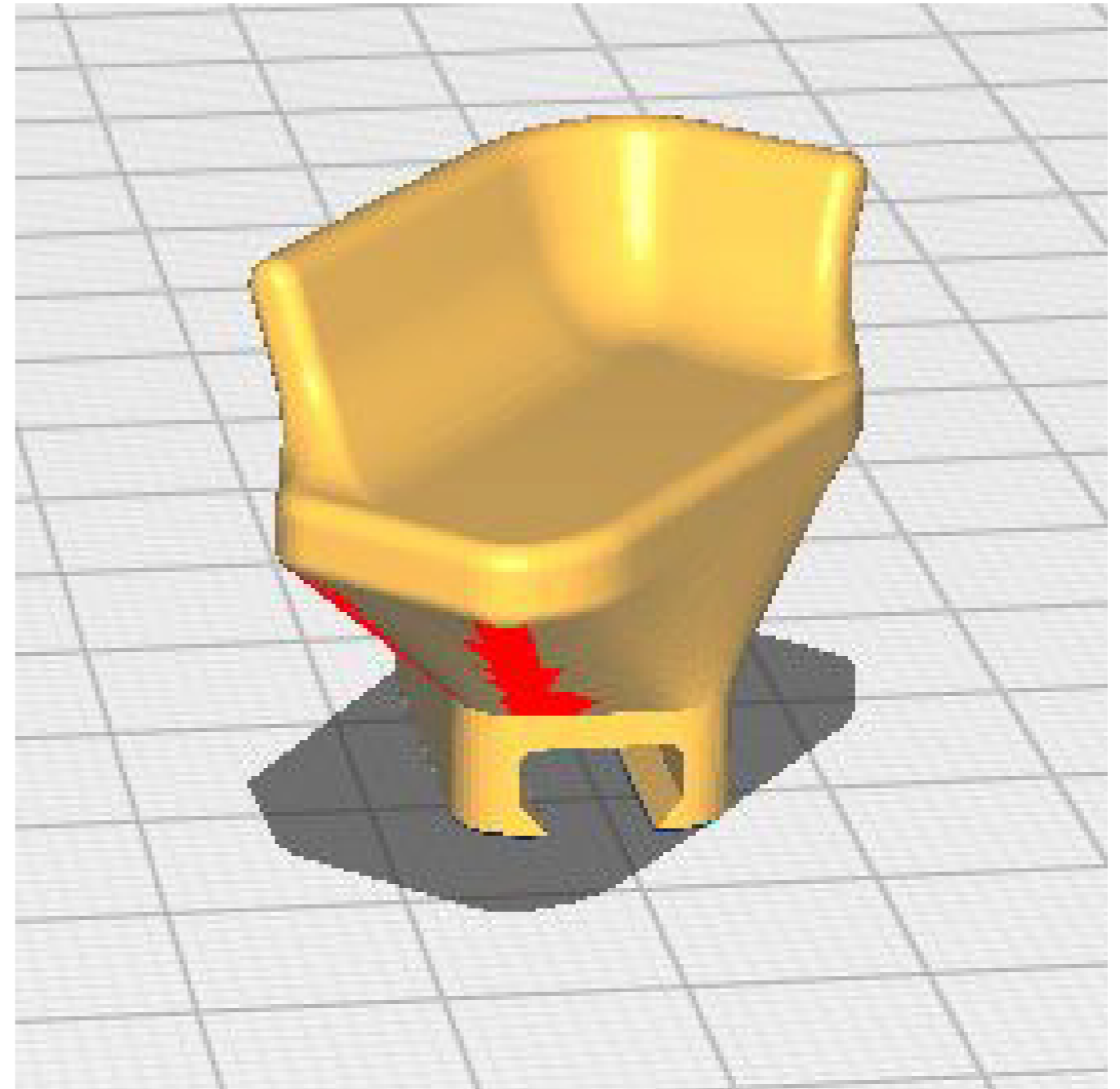

Positioning the model on  
the printing surface