

# 3D PRINTABLE MODEL

## SEMAPHORE-01

03.2015

EUROREPRAP.EU

### FDM process optimized:

- no print support needed
- small printers: 15x15 cm bed sizes are OK
- optimal for 0.4 mm nozzles
- recommended printing speed: 50 mm/s
- print layer height: 0.2mm (best detail: 0.15mm)

### Assembly optimized:

- no metal parts or additional components needed
- just glue, nail file and 1.75mm filament are used during assembly

### Compatibility:

- this model is a part of "Euroreprap Railroad Collection" which is a system consisting of trains, tracks and other railway objects.
- dimensions of completed model: 84x92x283 mm (3.3x3.62x11.14 in)

EUROREPRAP  
RAILROAD  
COLLECTION



### Availability:

- [www.ponoko.com/showroom/EUROREPRAP-EU](http://www.ponoko.com/showroom/EUROREPRAP-EU)
- for other than PayPal payment forms and discounts please first contact us by email: [contact@euroreprap.eu](mailto:contact@euroreprap.eu)

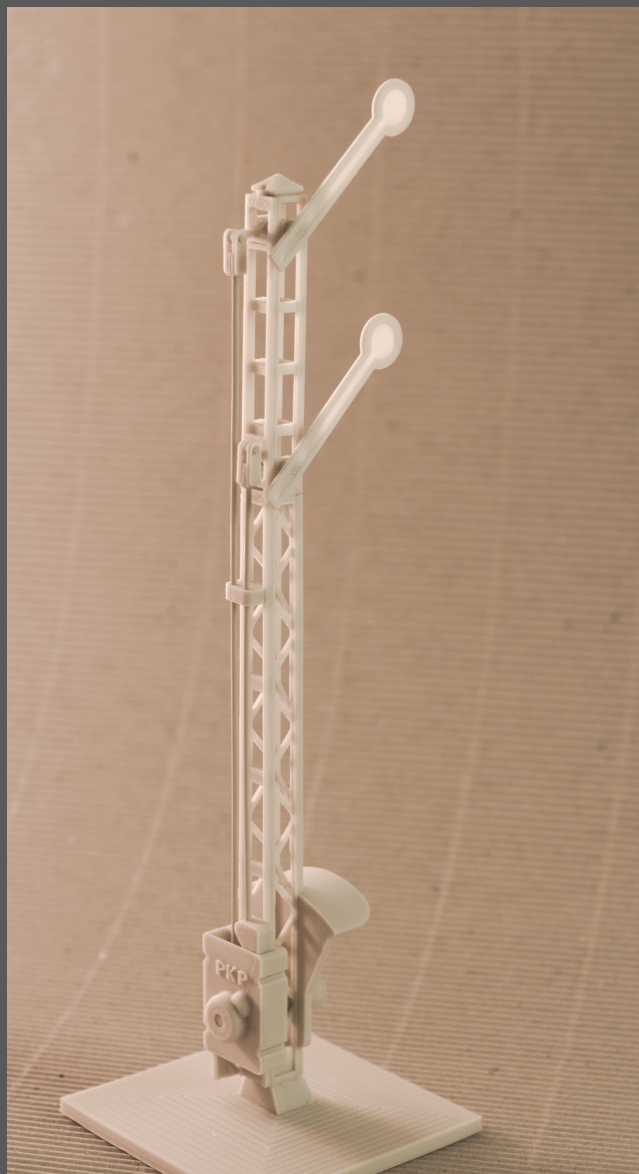

# ASSEMBLY

E-mail and website  
[contact@euroreprap.eu](mailto:contact@euroreprap.eu)  
[www.euroreprap.eu](http://www.euroreprap.eu)

# 3D PRINTABLE MODEL

## SEMAPHORE-01

03.2015

EUROREPRAP.EU

1.75 mm filament

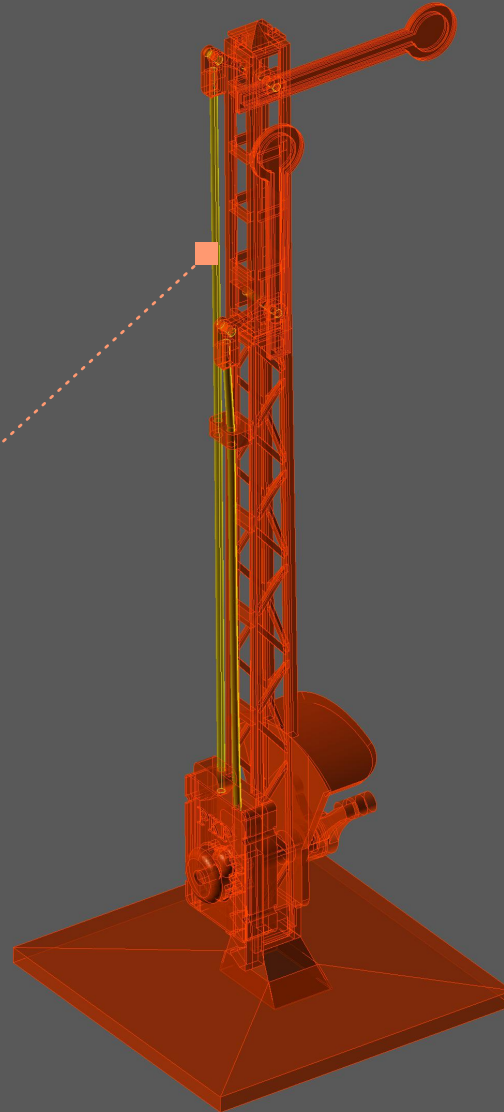

---

# 3D PRINTABLE MODEL

---

# SEMAPHORE-01

03.2015

EUROREPRAP.EU

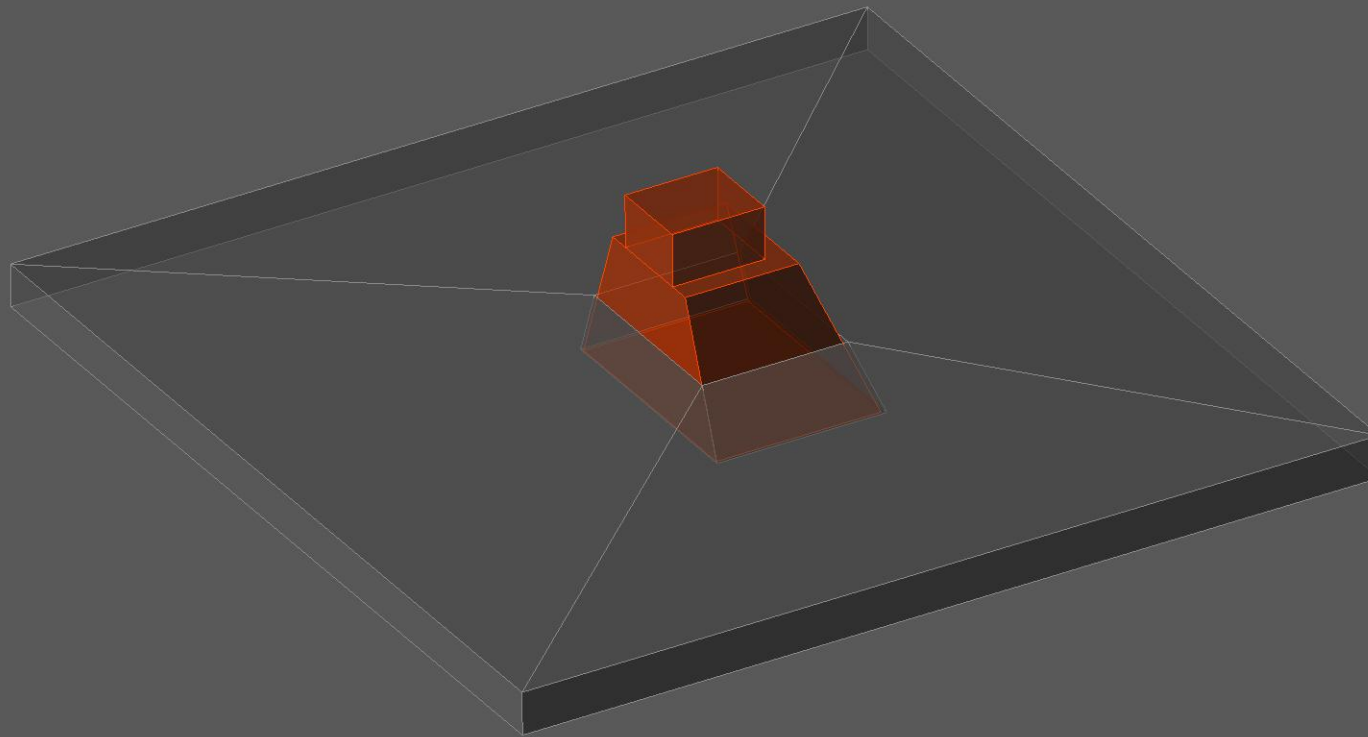

---

# 3D PRINTABLE MODEL

---

# SEMAPHORE-01

03.2015

EUROREPRAP.EU

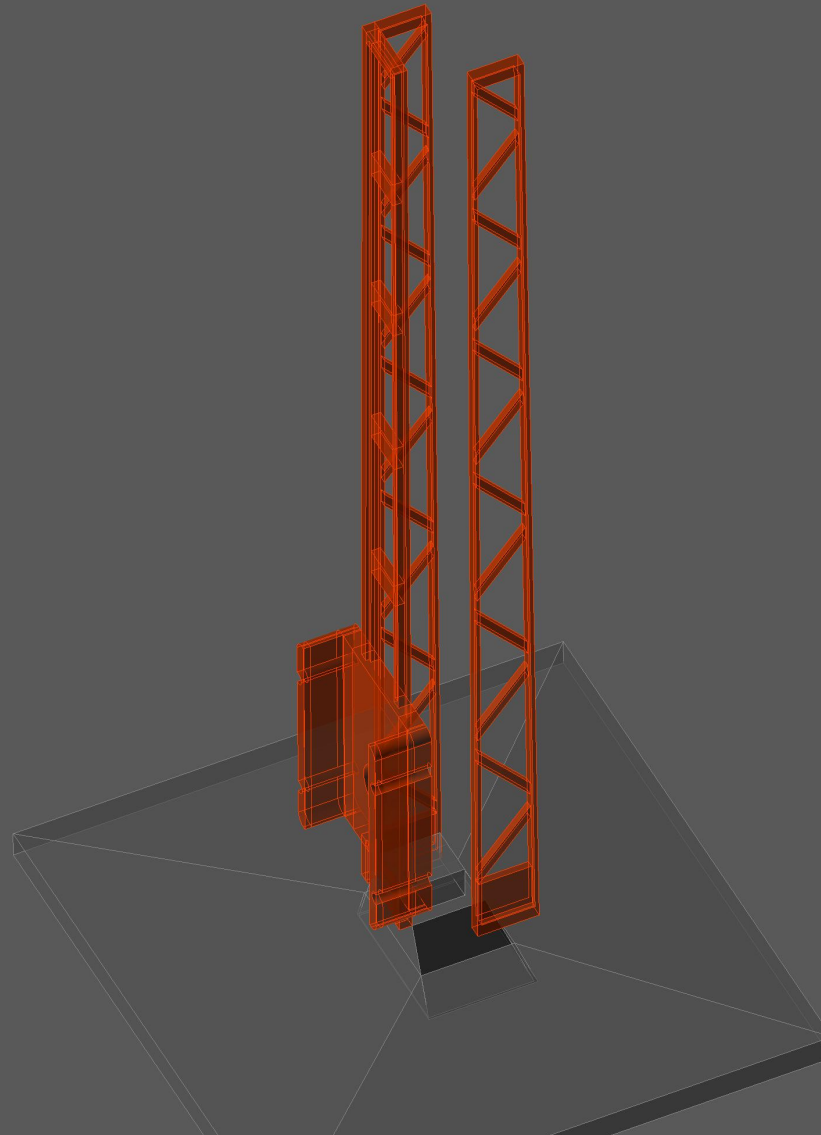

---

# 3D PRINTABLE MODEL

---

# SEMAPHORE-01

03.2015

EUROREPRAP.EU

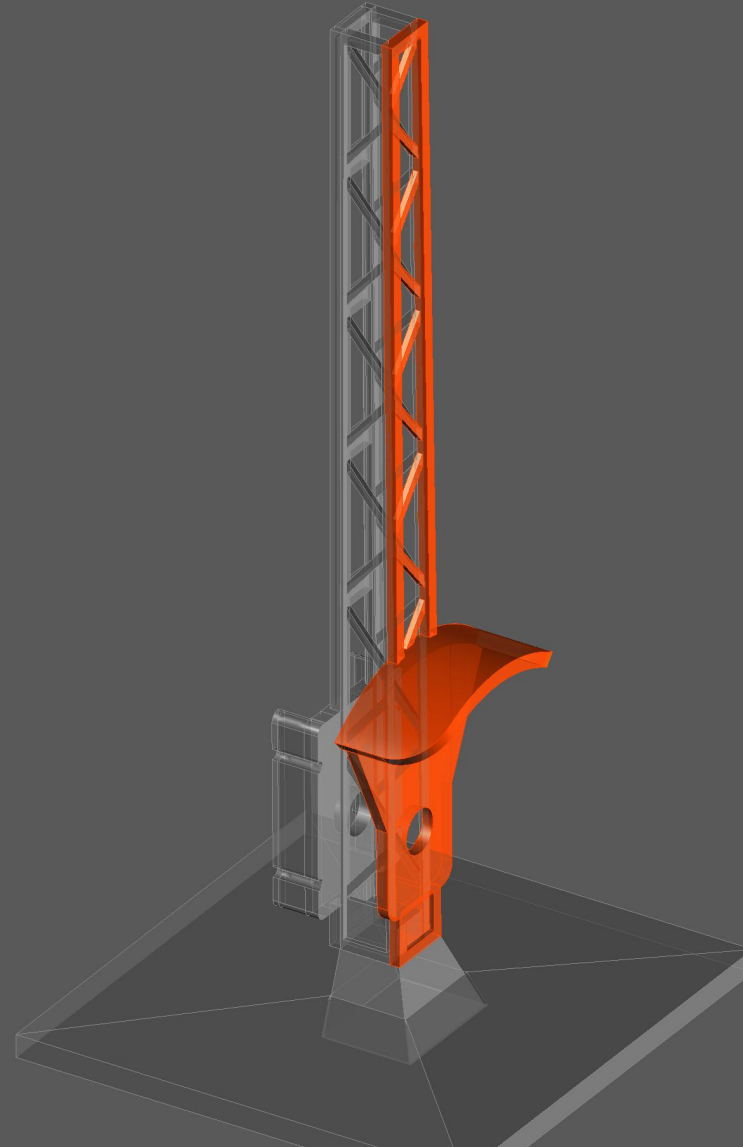

# 3D PRINTABLE MODEL

## SEMAPHORE-01

03.2015

EUROREPRAP.EU

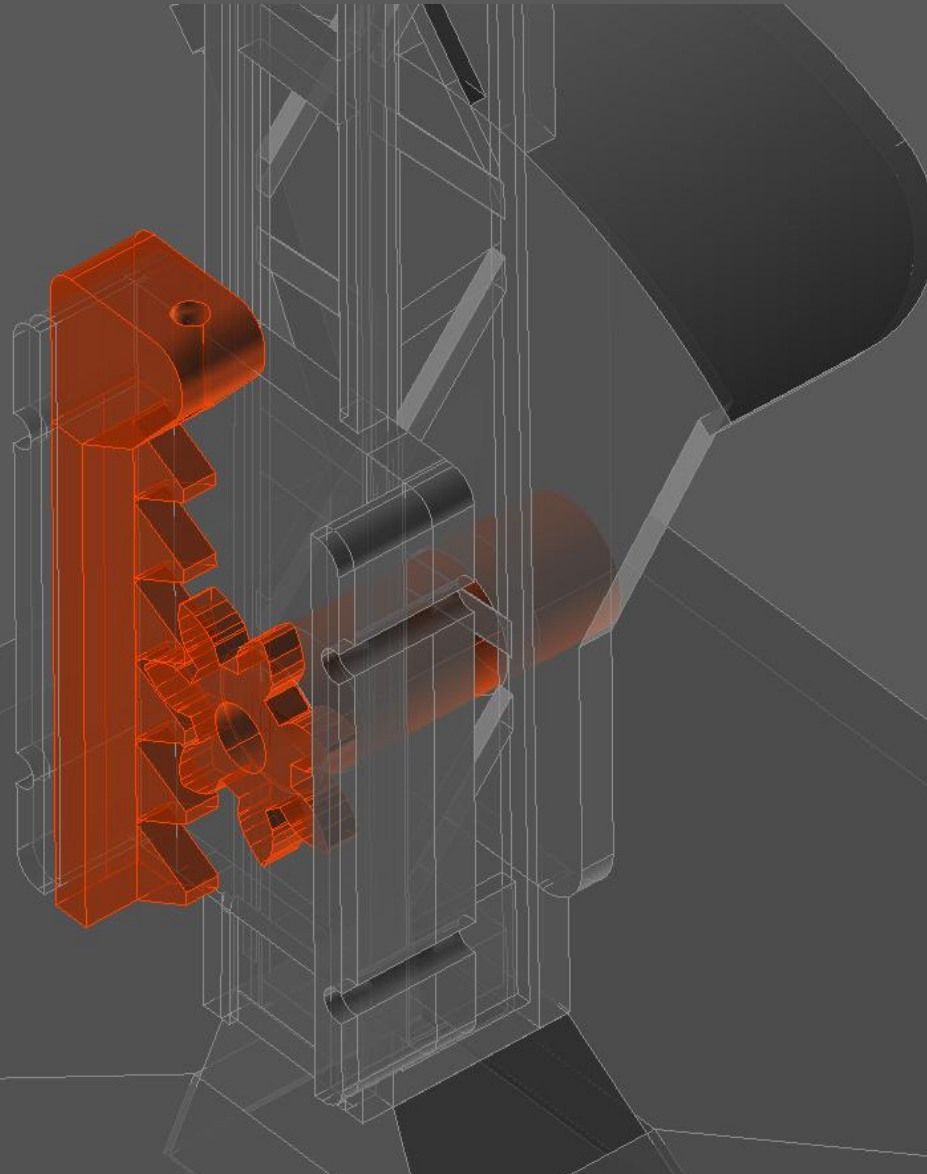

# 3D PRINTABLE MODEL

## SEMAPHORE-01

03.2015

EUROREPRAP.EU

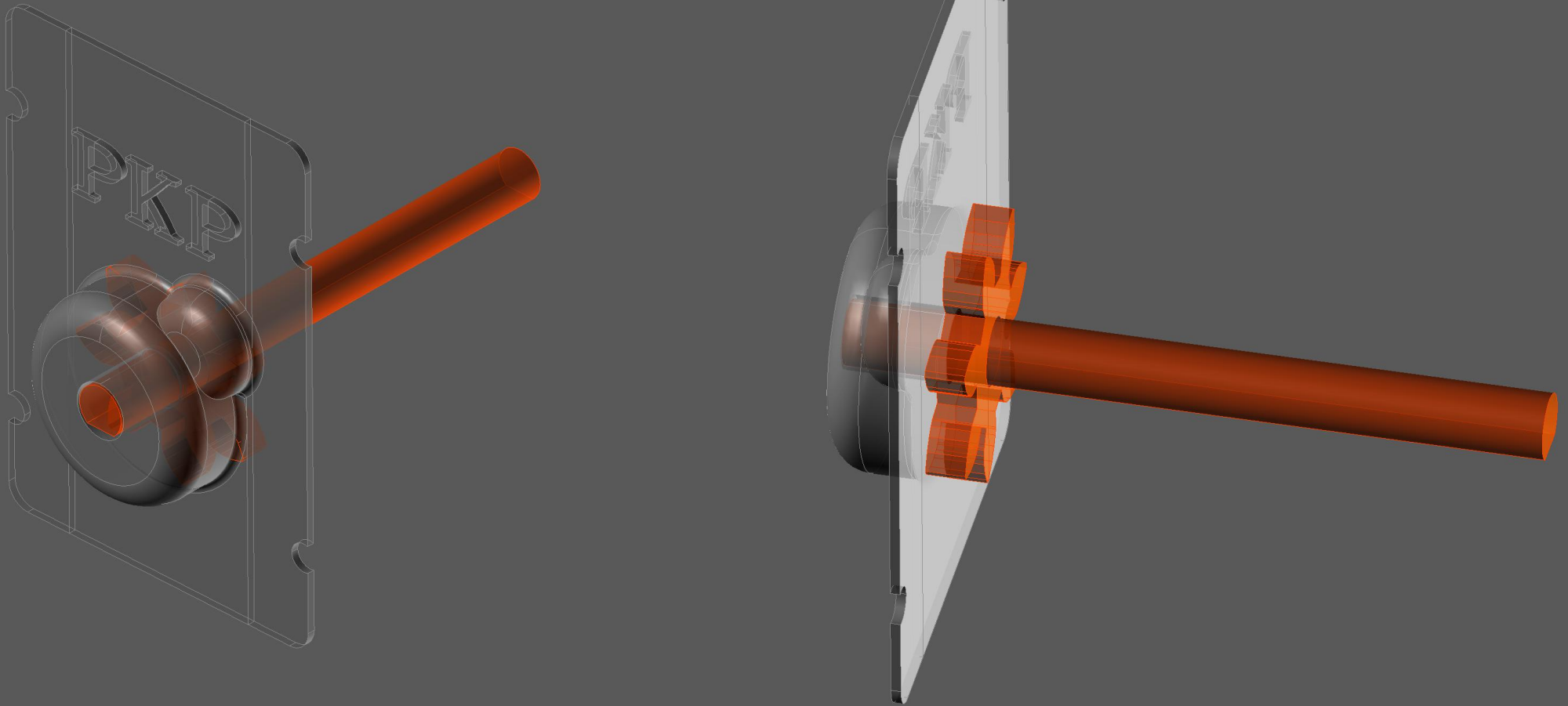

# 3D PRINTABLE MODEL

## SEMAPHORE-01

03.2015

EUROREPRAP.EU

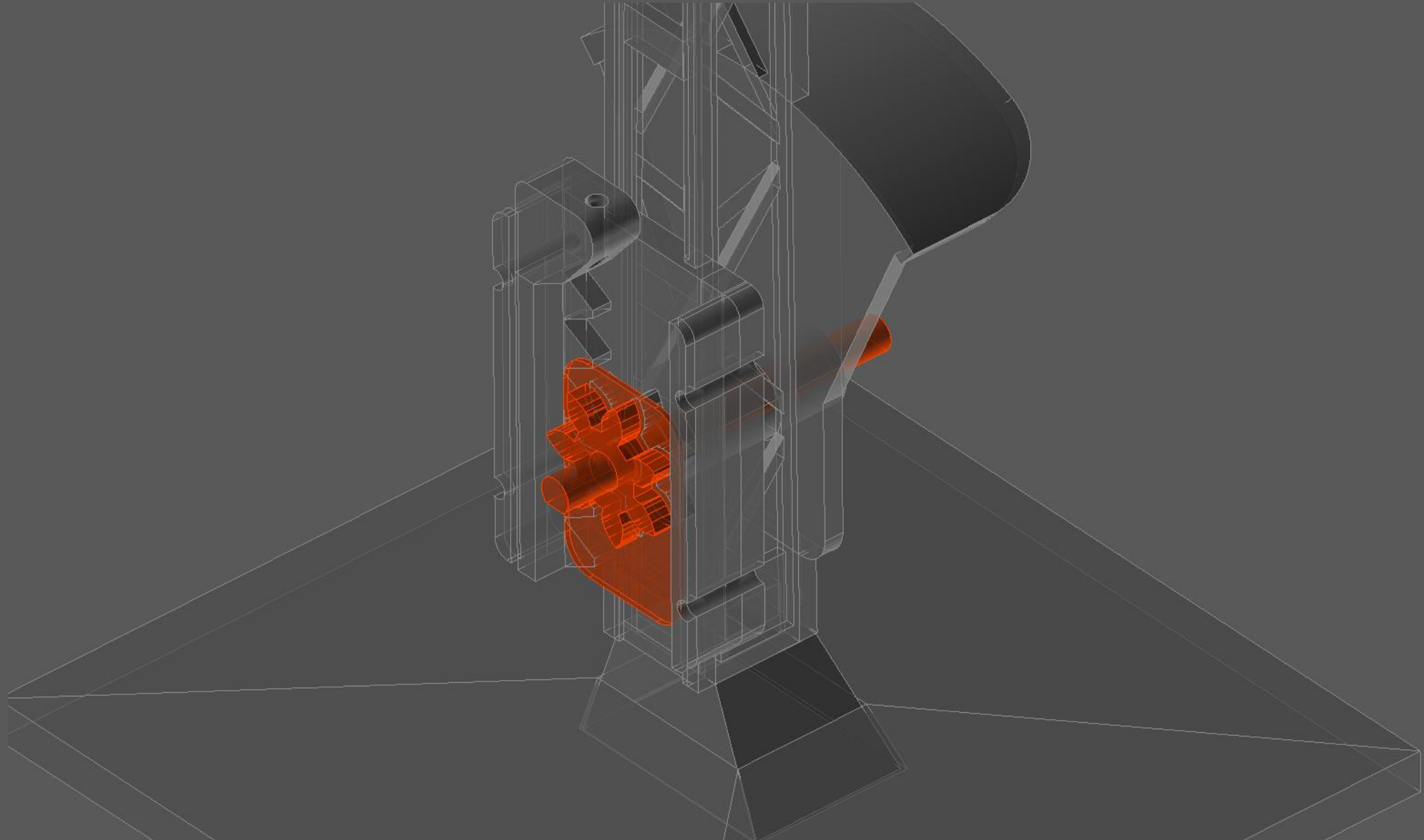



# 3D PRINTABLE MODEL

# SEMAPHORE-01

03.2015

EUROREPRAP.EU

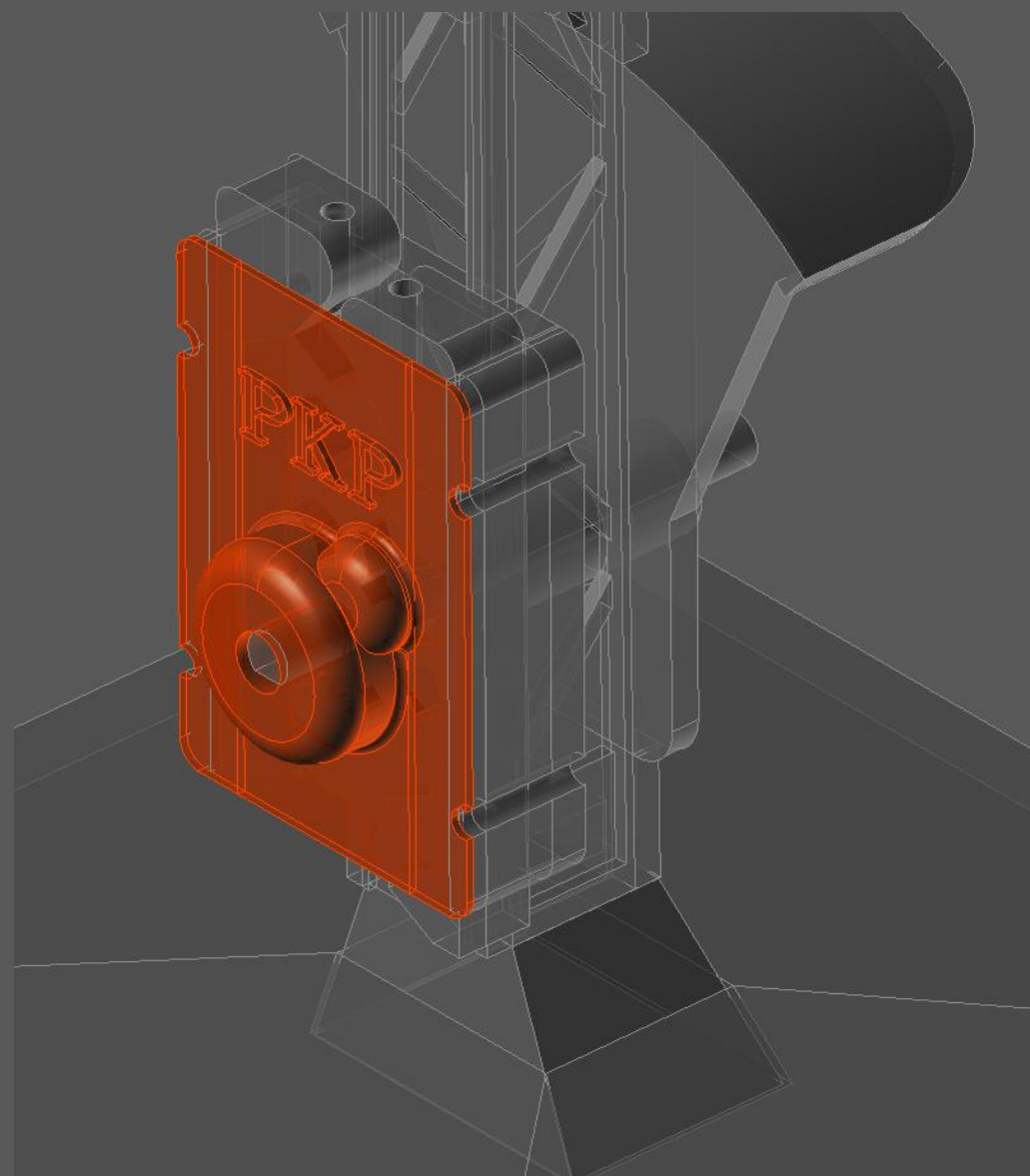
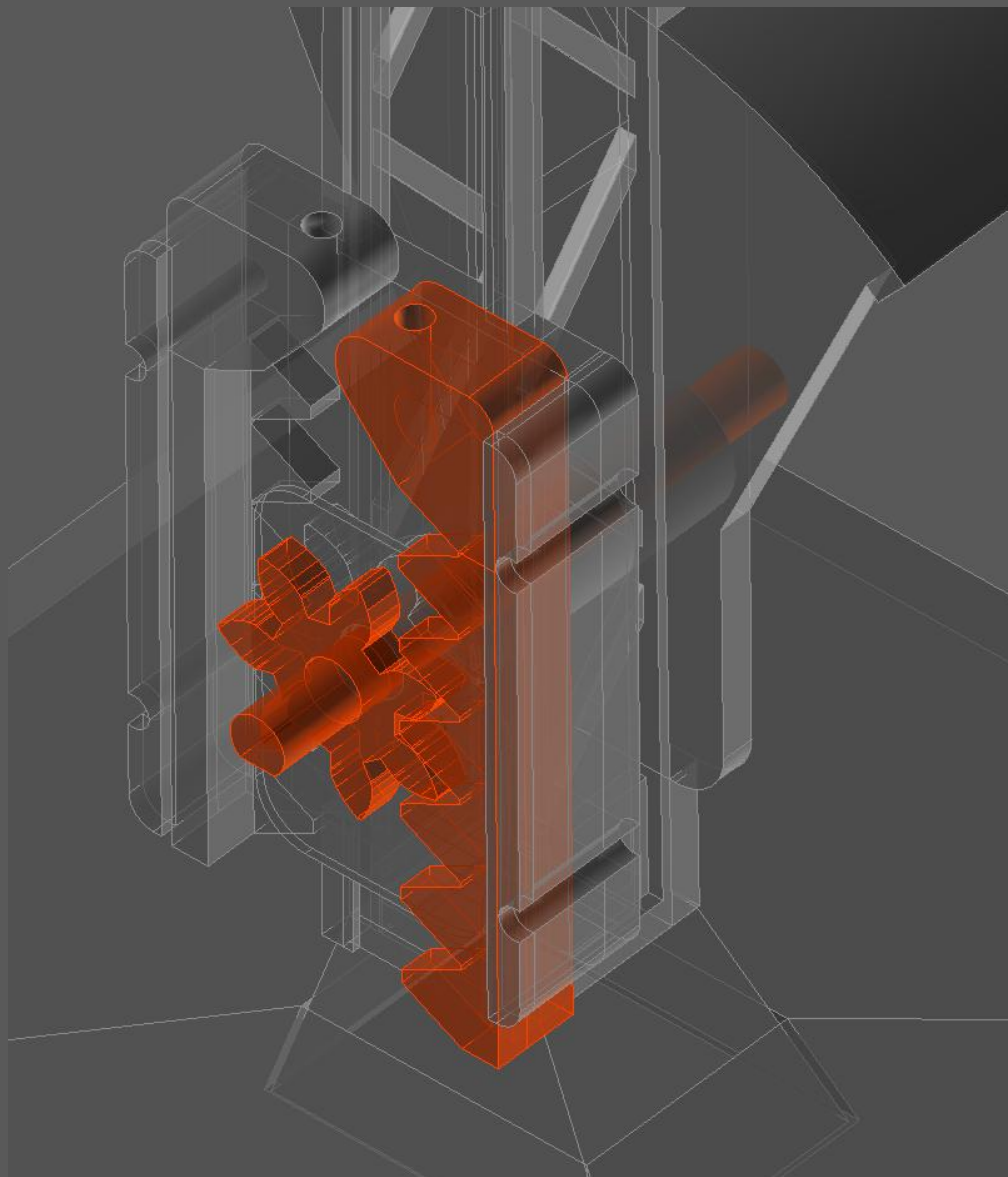

# 3D PRINTABLE MODEL

## SEMAPHORE-01

03.2015

EUROREPRAP.EU

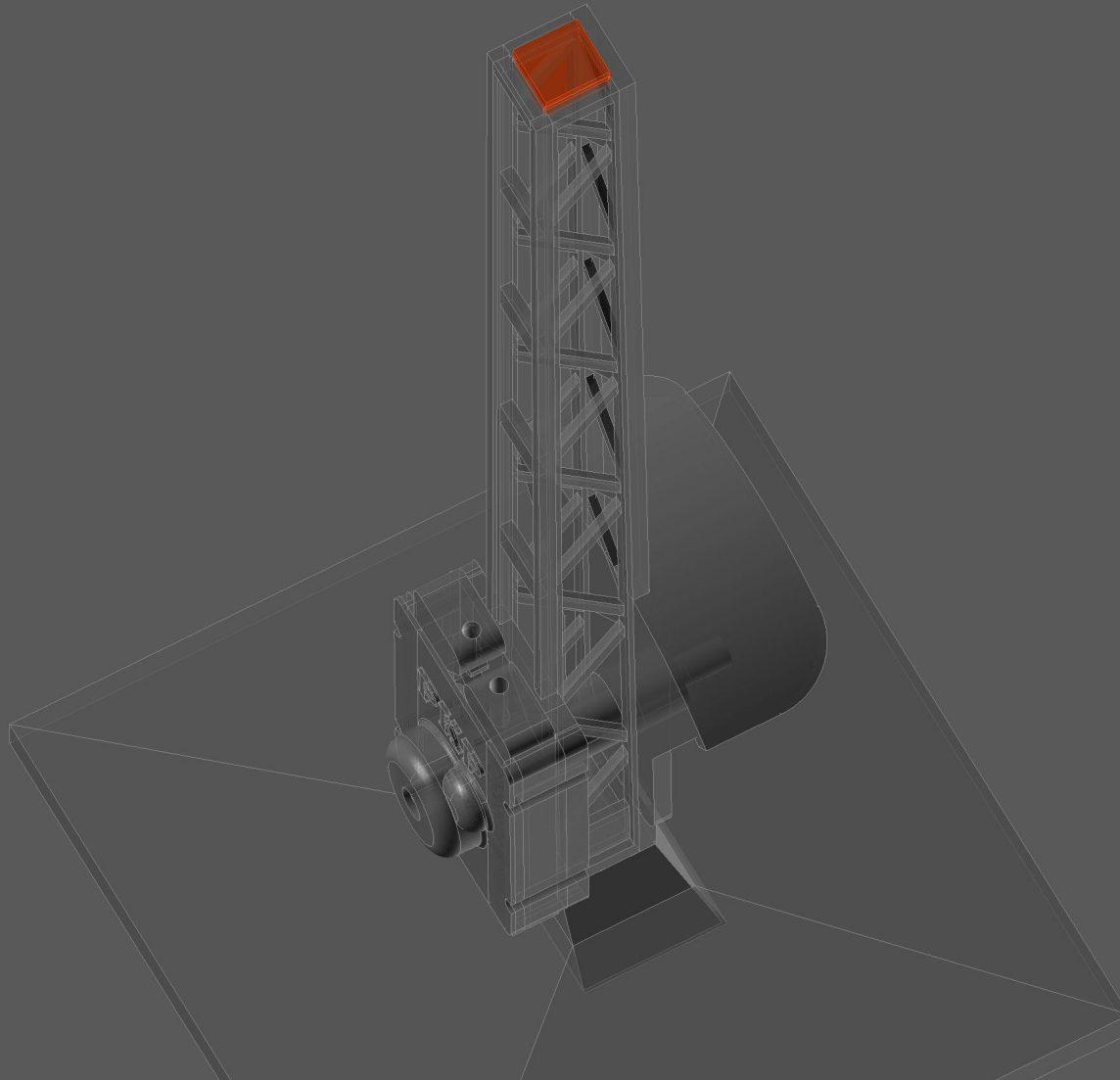

# 3D PRINTABLE MODEL

# SEMAPHORE-01

03.2015

EUROREPRAP.EU

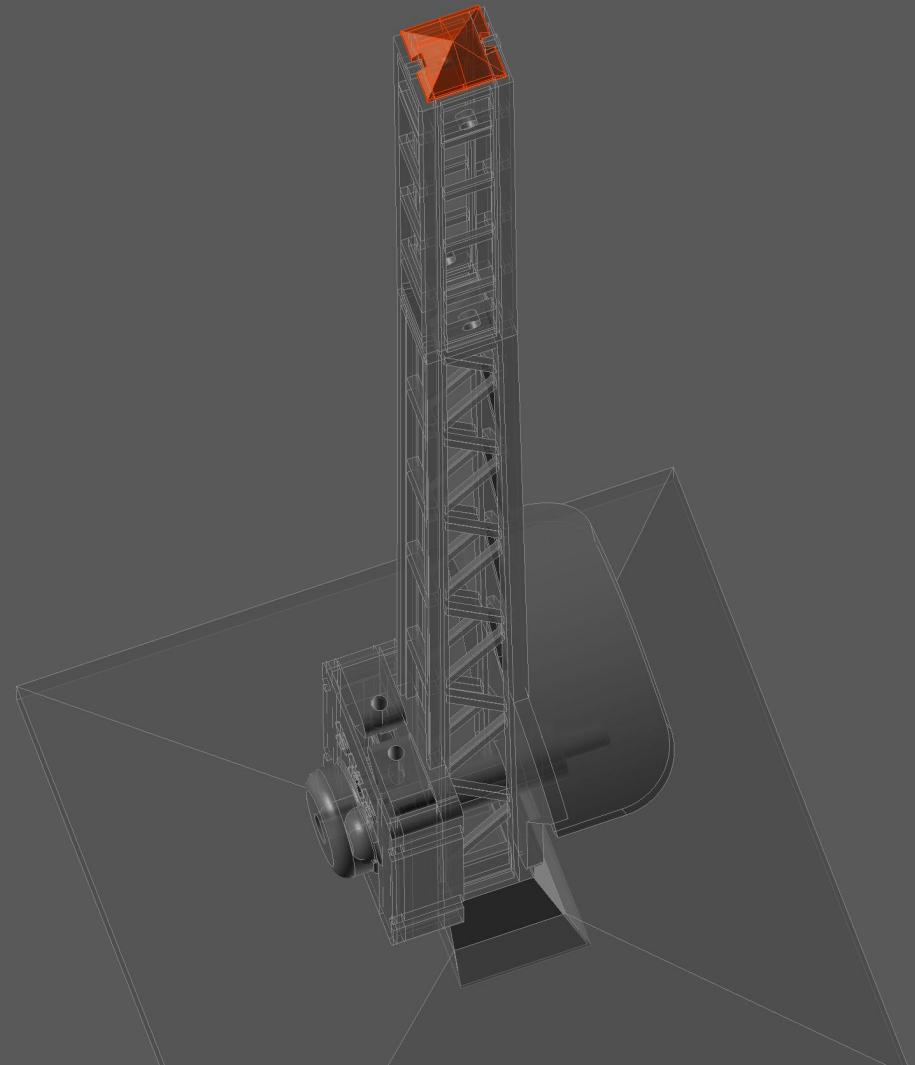
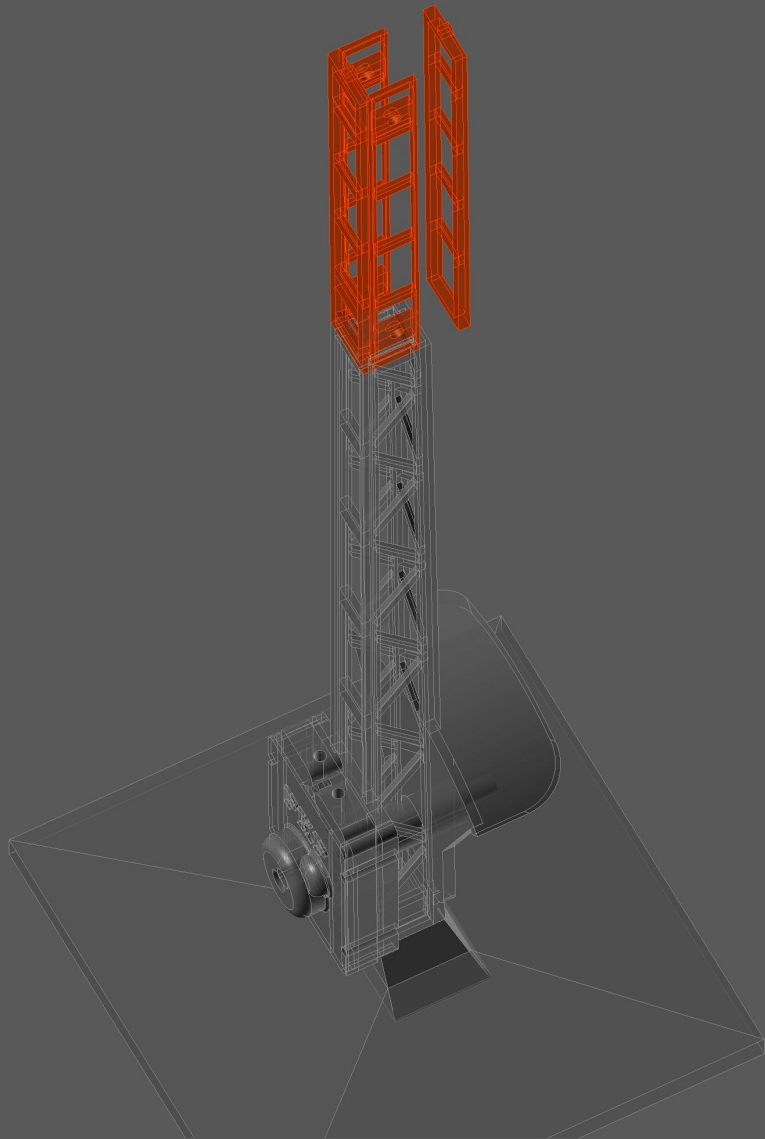

# 3D PRINTABLE MODEL

# SEMAPHORE-01

03.2015

EUROREPRAP.EU

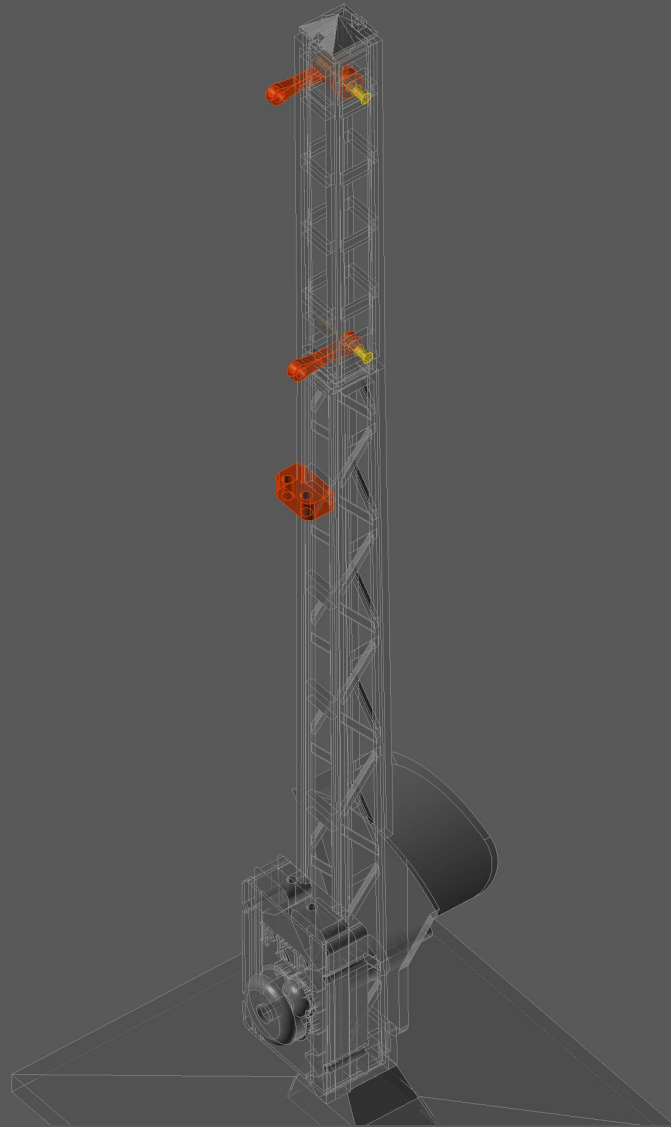

1.75 mm filament

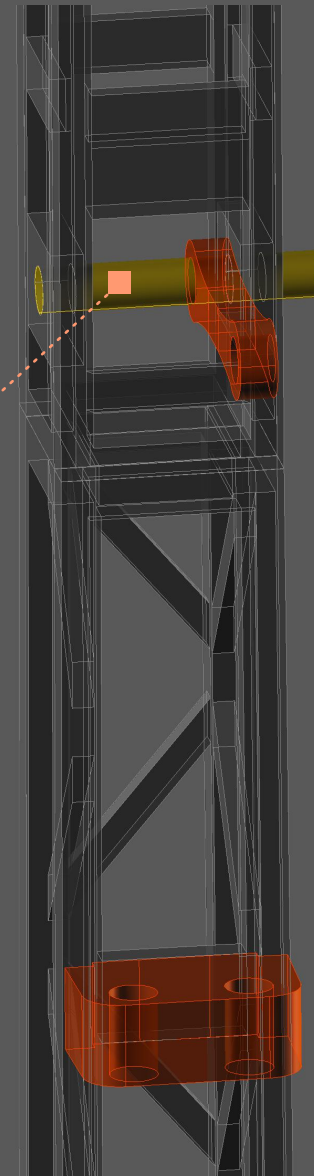

# 3D PRINTABLE MODEL

## SEMAPHORE-01

03.2015

EUROREPRAP.EU

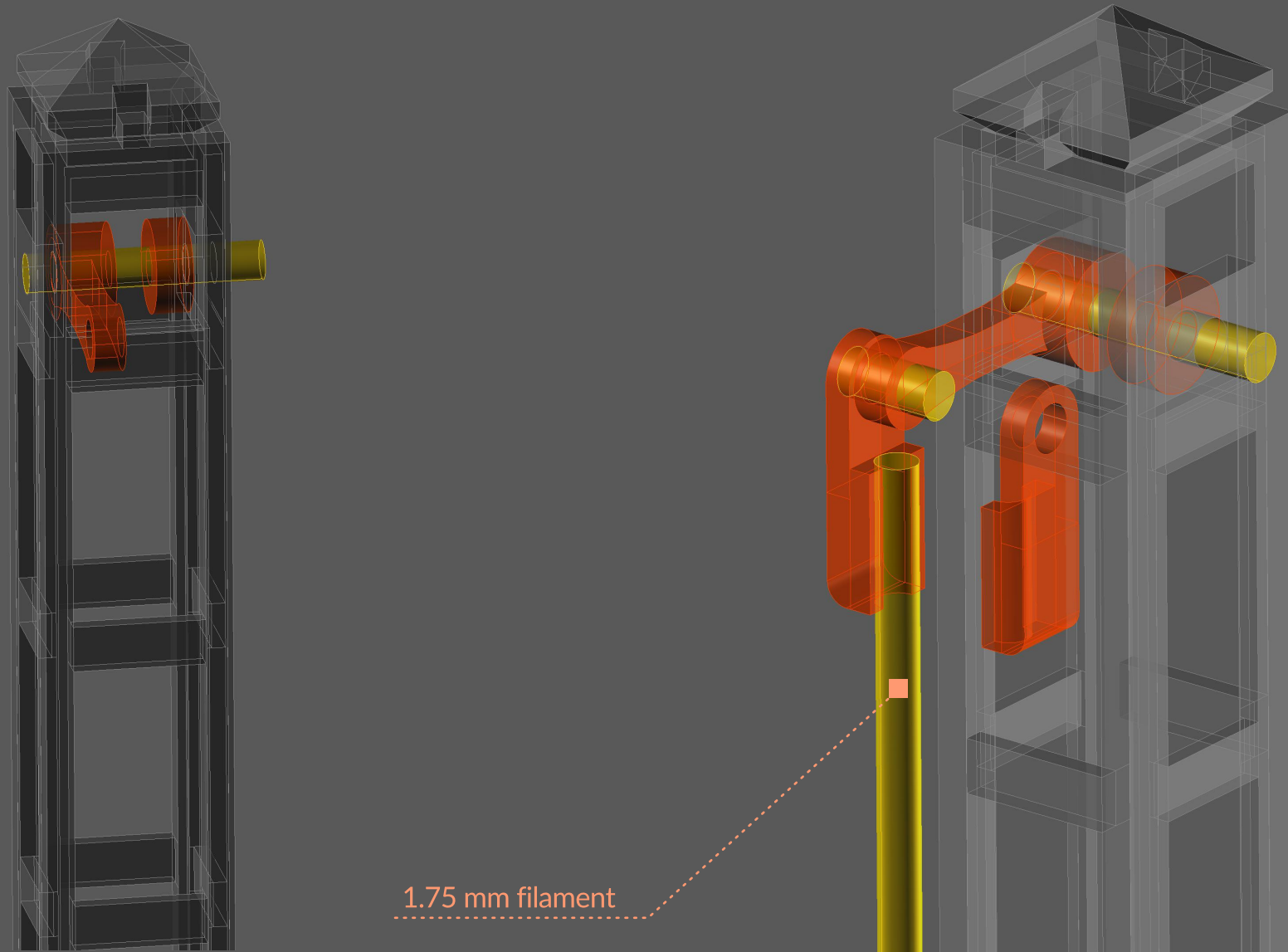

# 3D PRINTABLE MODEL

# SEMAPHORE-01

03.2015

EUROREPRAP.EU

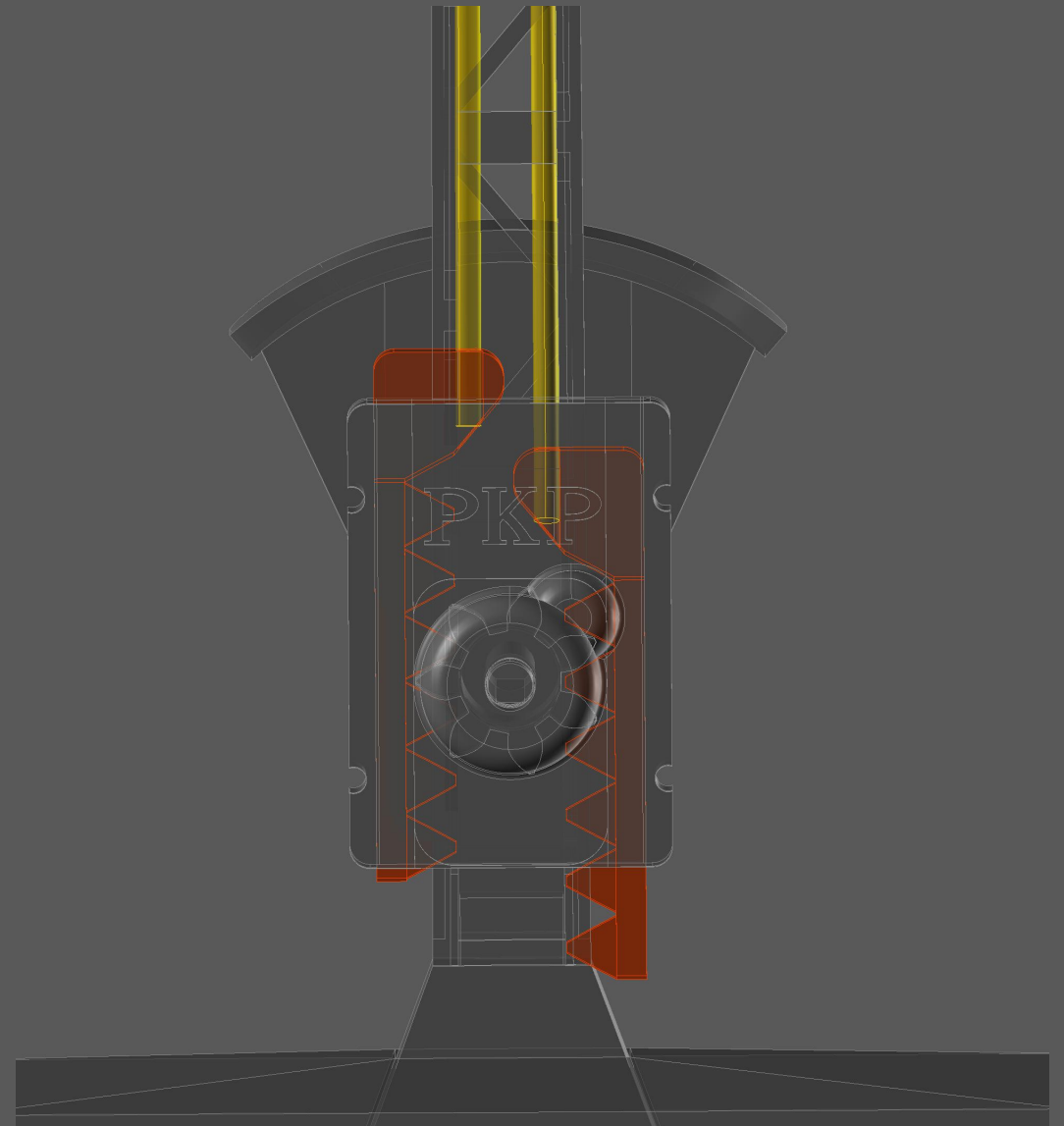
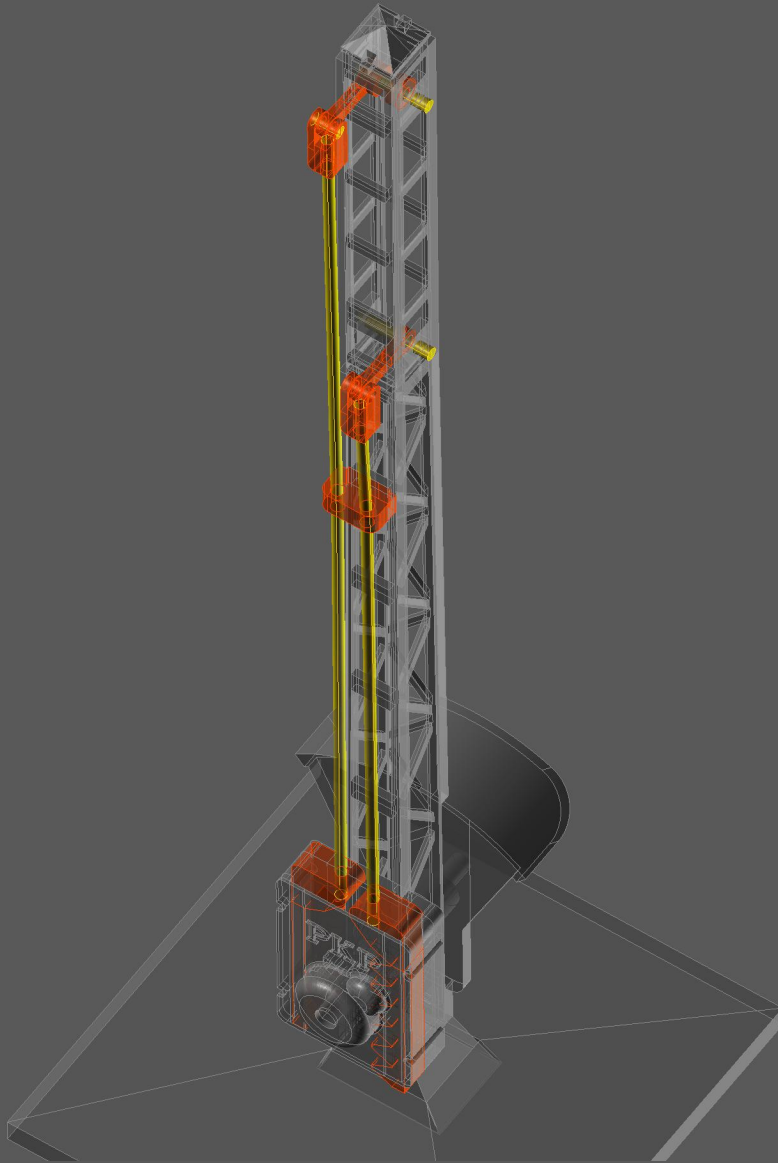

# 3D PRINTABLE MODEL

# SEMAPHORE-01

03.2015

EUROREPRAP.EU

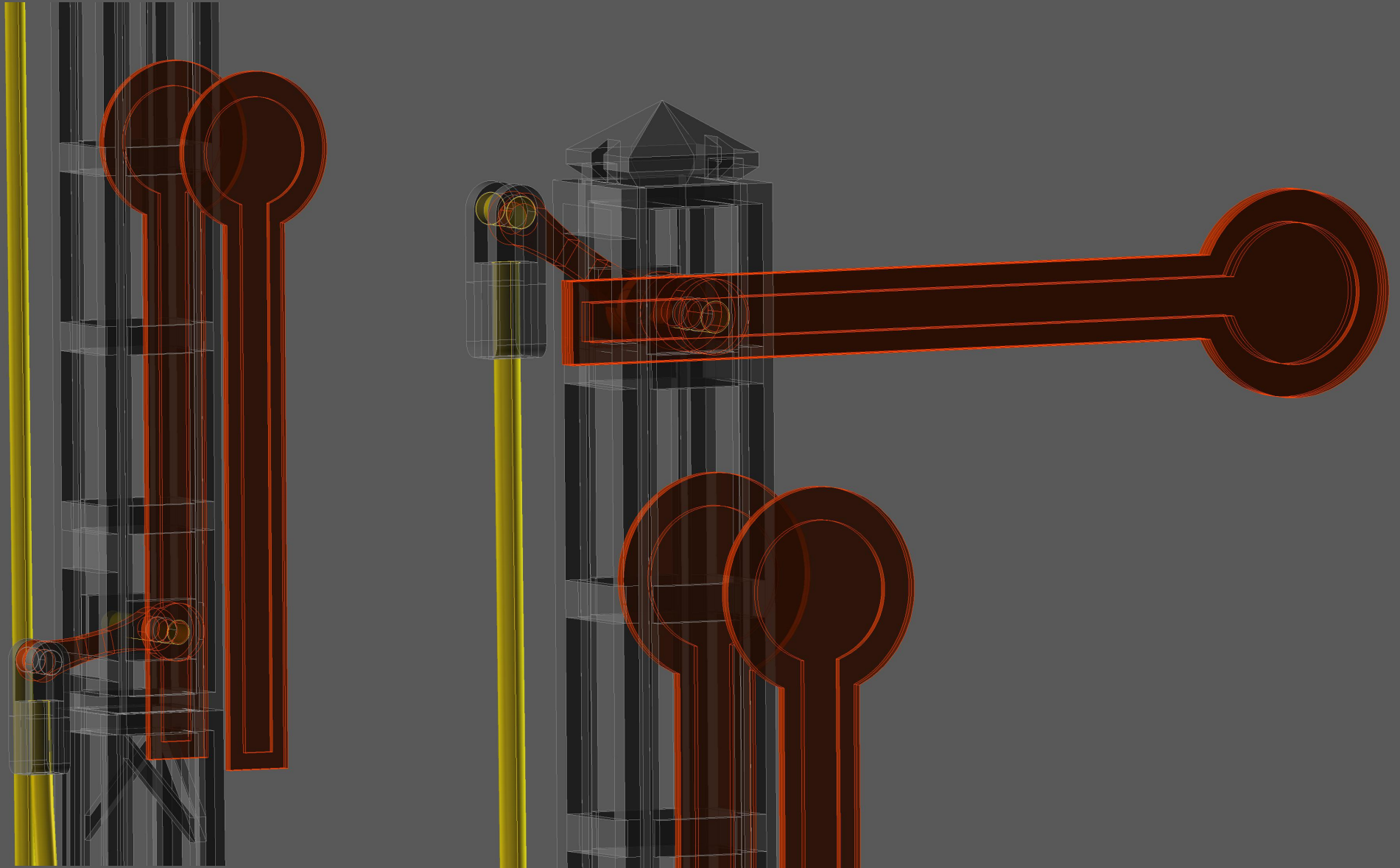

# 3D PRINTABLE MODEL

# SEMAPHORE-01

03.2015

EUROREPRAP.EU

