

For 12 V Motors: Speed control and stall protection

Small and handy power tools with 12 V supply are becoming more and more common in hobby labs. These tools become even more versatile with a little additional electronics.

Small, high-speed 12 V drills are now standard equipment in workshop and lab. The range of application of these machines for PCB machining can be considerably extended if the speed can be adjusted over a wide range. However with a normal, adjustable power supply unit, the torque of the motor decreases with the speed.

The circuit described here allows speed control of a DC motor over an extremely wide range; the speed remains load-independent even in the lowest range. A motor current limit prevents damage to the motor and the supply unit in case of overload. The actuator is designed as a switching controller, which reduces its power loss, especially when drilling at low speed and high torque. The sample device was developed for a Bühler motor type 13.40.11, but as tests have shown, it is suitable for any other 12 V motor with a maximum current consumption of 4 A.

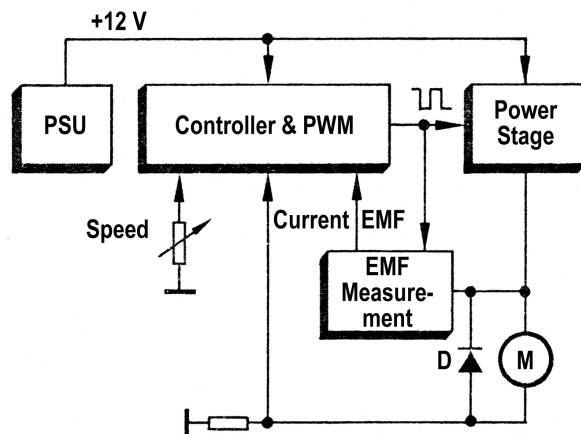

① Block diagram for a DC motor control system with speed control and adjustable stall protection

The circuit's operation can be seen from the block diagram (Fig. 1): The motor is supplied with a square-wave voltage the duty cycle of which is variable. After the induction current has decayed, the EMF of the motor (= open-circuit voltage in generator operation) is measured during the pauses between pulses, and then fed to the controller as an actual value proportional to the speed. The controller activates the motor output stage via the pulse width modulator in such a way that the motor EMF and thus the speed remain constant regardless of the load. To prevent the motor from being damaged in the event of prolonged stalling, an adjustable current limiter is provided.

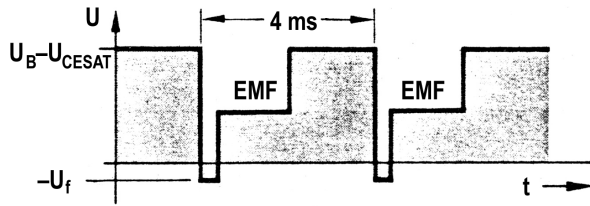

② PWM motor voltage

The motor voltage diagram illustrates how the circuit works (Fig. 2). During the 'on' phase of the output stage, virtually the rectifier's output voltage after the rectifier present at the motor. After the output stage is disabled, the armature voltage drops (due to the inductance of the motor) until the free-wheeling diode D conducts at $-U_f$ and the stored energy is dissipated. After that, the armature voltage rises to the EMF given by the motor's speed and specs. This voltage is then sampled and used for regulation.

Since the switching frequency is low (250 Hz), the switching losses can be kept small with simple means; there is practically no radio interference. However, some motors produce audible buzzing sounds with PWM control. This flaw, however, has no influence on the motor's longevity.

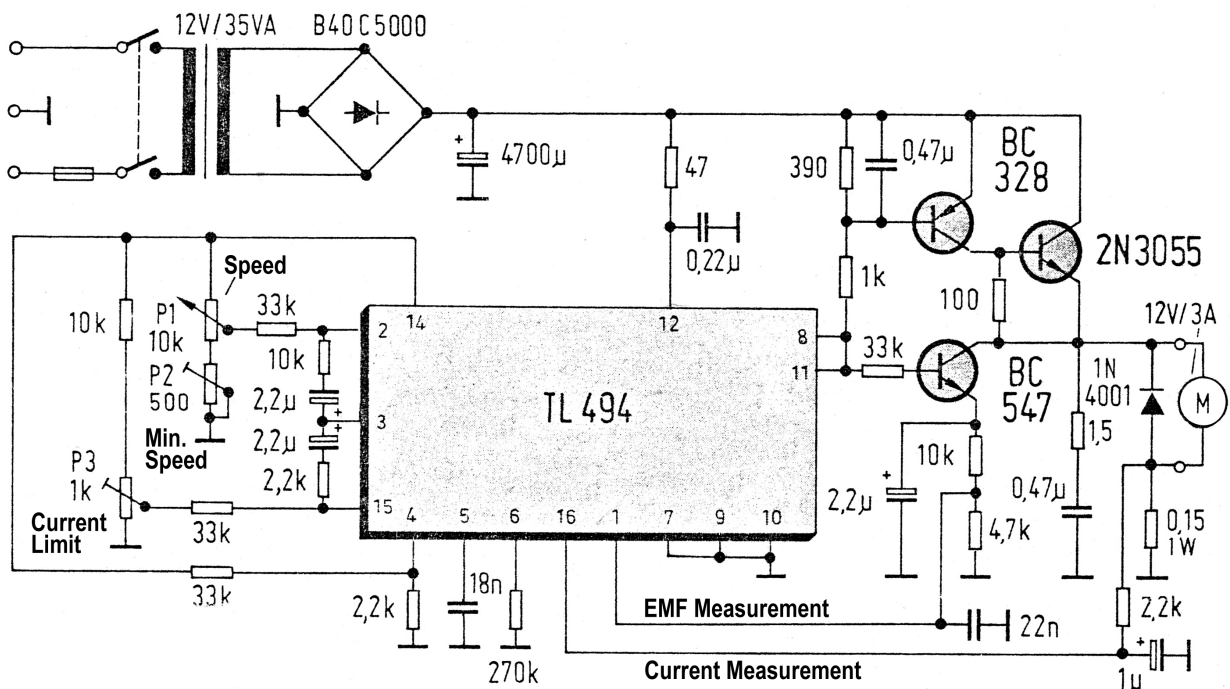

③ Overall diagram with speed control, adjustable minimum speed and stall protection (current limiter)

A transformer with bridge rectifier and smoothing capacitor supplies the voltage for the unit. The entire control circuit with clock generator, pulse width modulator, two opamps and the voltage reference is combined in the TL494 chip (Fig. 3).

This component, originally developed for switch-mode power supplies, is operated here with a clock frequency of 250 Hz. Although the TL494's minimum oscillator frequency is specified at 1 kHz, the circuit still works perfectly at 250 Hz. Its open-collector output (pins 8 and 11) drives the power output stage, consisting of a BC328 and a 2N3055. The 2N3055 needs a small heat sink to dissipate the switching losses of about 5 W.

The capacitor at the base of the BC328 and the RC element from the collector of the 2N3055 to ground suppress oscillations that can occur with the motor's inductive load. Parallel to the motor is a free-wheeling diode D. The BC547 with the surrounding components serves as sample-and-hold element used for EMF measurement. The measured EMF voltage is divided and fed to pin 1 of the TL494, a small capacitor short-circuits interference.

The speed setpoint is derived from the internal 5 V reference (pin 14) of the TL 494 and fed to the setpoint input (pin 2). The RC element between pins 2 and 3 configures the integrated op amp as a PI (proportional-integral) controller. To allow sufficient time for the EMF measurement, the TL494's minimum sensing period is increased by a bias voltage at pin 4.

The motor current is sensed with a 0.15 Ohm resistor and, after smoothing with an RC element, fed to the second opamp in the TL494 (pin 16). The setpoint can be adapted to the motor in use with a trimmer pot. The control behaviour in constant current mode is determined with the RC element from pin 3 to pin 15.

The circuit can be built on matrix board or on the PCB suggested here (Figs. 4 and 5). After powering up, check the clock frequency at pin 5 (250 Hz) and set the current limit potentiometer to its centre position. When a motor is connected, it must be possible to adjust its speed from zero to the maximum value; it must also remain stable during load changes.

The minimum speed at which the motor runs without jerking can be set with the 500 Ohm trimmer pot. Finally, with the motor blocked, the maximum current consumption can be set to the desired value. The easiest way to do this is to measure the voltage drop across the 0.15 Ohm current sensing resistor.

Jochen Jirmann

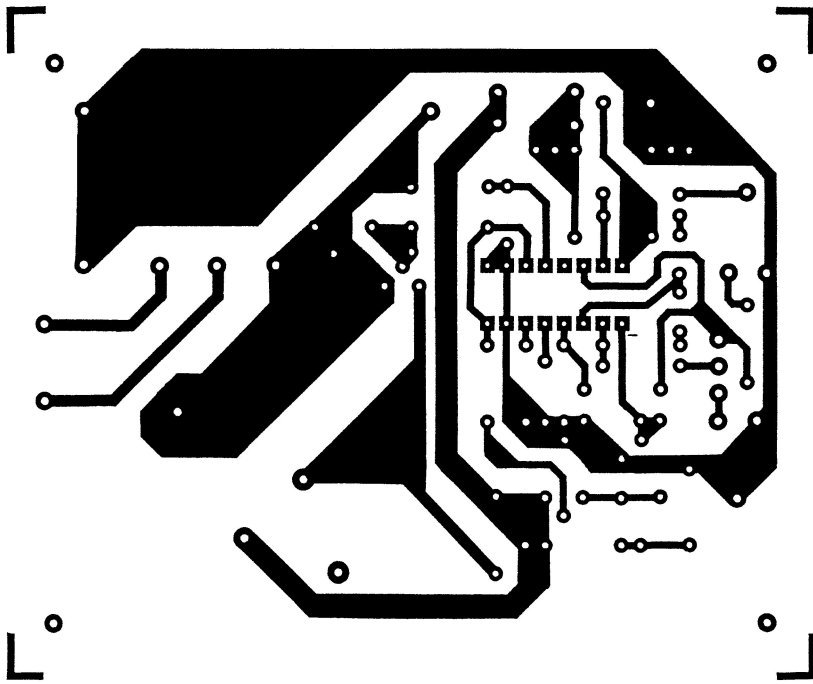

(4) PCB layout

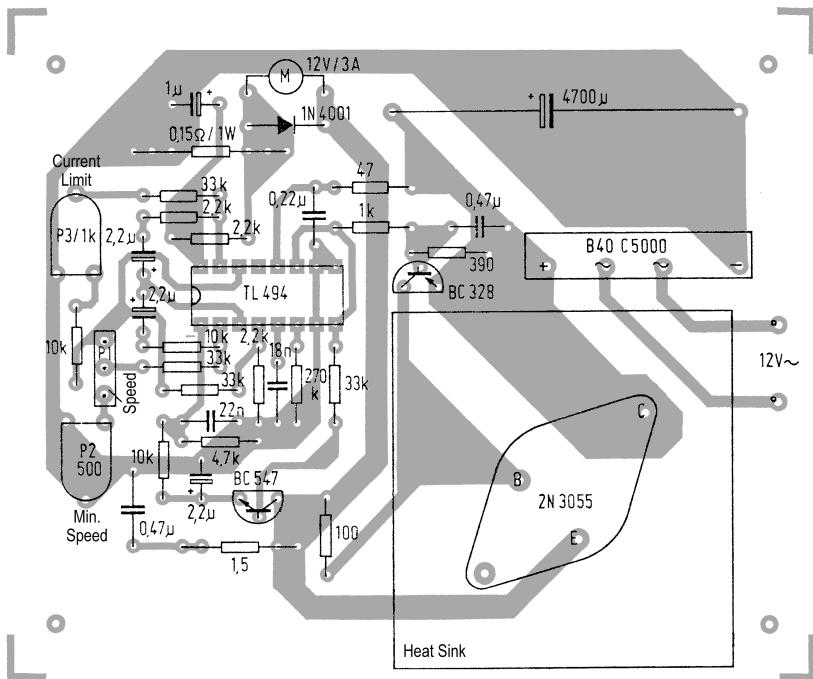

(5) Component layout. Only a mains transformer (12 V/3 A) has to be connected.