



Model

Parameters Run Reset

- Tormach
- Roughing waterline
- Finishing waterline

2D Geometry

Machining

Simulation



Setup

Main parameters

- Approach/Return
  - Approach reference po: Short
  - Return reference point: Short
  - Tool change position: From the previous op
  - Workpiece setup: From the previous op
  - Workpiece CS: From the previous op
  - Local CS: Off
- Rotary Axis
  - A (Axis A Position)
- Linear Axis
  - X (Axis X Position)
  - XX (Rotary Table Position)
  - Y (Axis Y Position)
  - Z (Axis Z Position)

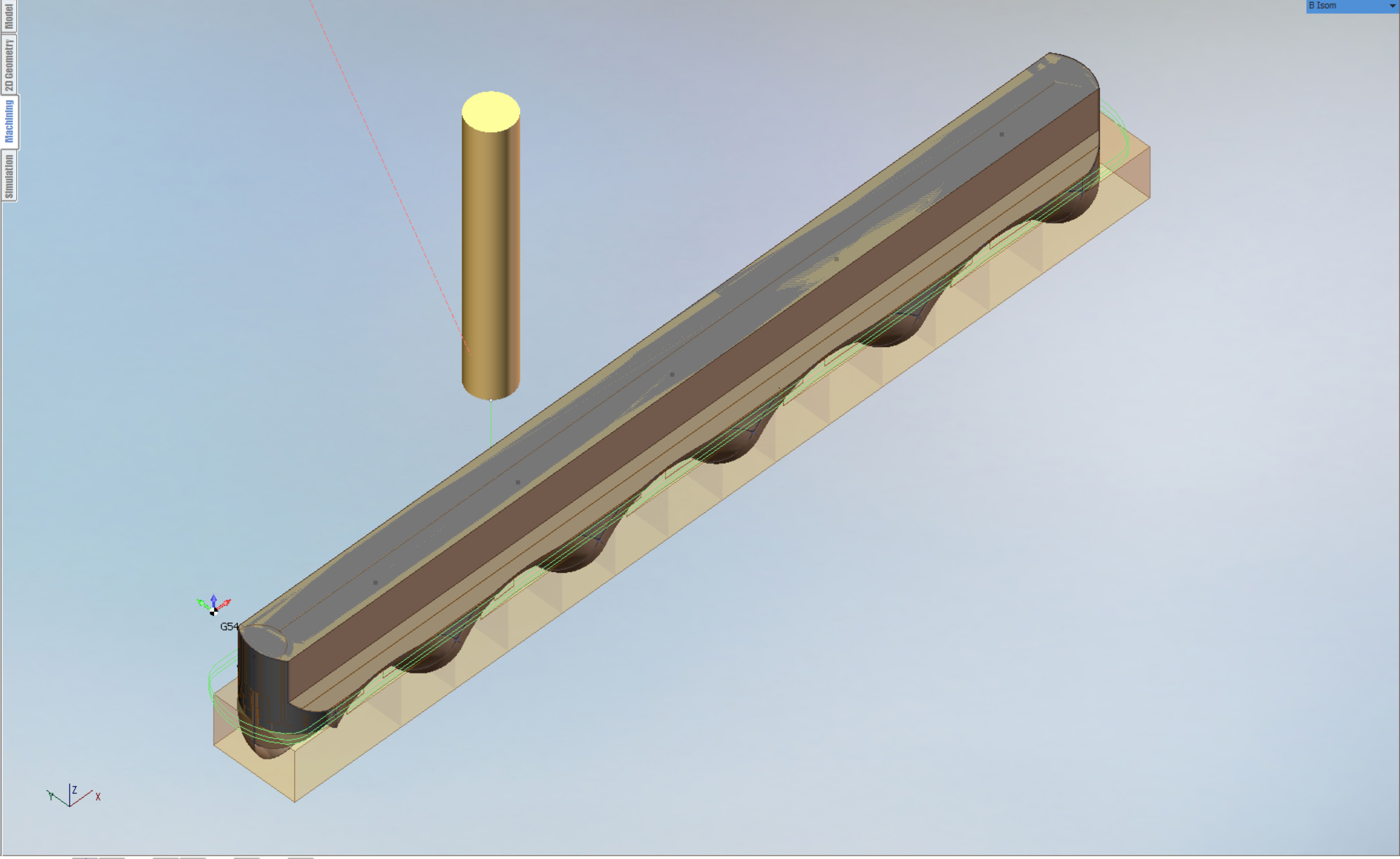

Tools list Postprocessor

