

STEERING SYSTEM

INTRODUCTION:

By taking less weight and steering ratio into consideration we have decided to take a steering system called PITMAN ARM steering

SELECTION OF STEERING SYSTEM

PARAMETER	PITMAN ARM	RACK AND PINION
COMPLEXITY	Less complex. Can be easily machined.	More complex than pitman arm. System of gears are used.
DURABILITY	Contacting surfaces are less which leads to high durability.	More wear and tear takes place due to gears.
VIBRATION	Vibration is less.	More vibration is transferred
WEIGHT	Less weight compared to other steering systems.	More weight.
TURNING SENSITIVITY	Quick turns can be achieved in sharp corners since the steering ratio used is 1:1.	During turning 3 to 4 complete revolutions are required from lock to lock.

STEERING RATIO

The steering ratio is a ratio between the steering wheel turning angle to the wheel turning angle. We are using a steering ratio of 1:1. i.e., The wheel turning angle is same as that of the steering wheel.

Advantage of using 1:1 steering ratio

- Less effort can be put by the driver.
- Quick turn in the sharp corners in the race track.

TURNING RADIUS

The circular arc formed by the turning path radius of the front outside tire of a vehicle.

Turning radius $r = \frac{\text{Track width} + \text{Wheel base}}{2}$

$$2 \sin \theta$$

where, θ = average steer angle.

Also we have one more relation by sine law,

$$\frac{r}{\sin 90^\circ} = \frac{\text{wheel base}}{\sin \theta}$$

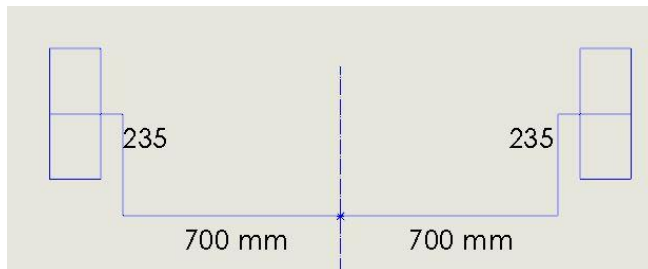
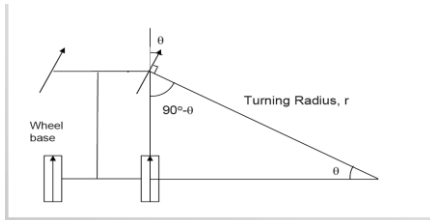

By analysis of various suspension in suspension analyser.

Camber angle: 2° (Negative)

The angle of wheel with respect to vertical axis from front view

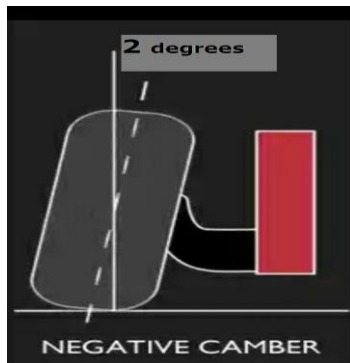

Advantages:

- Easy to turn
- Easy handling
- Better traction
- It generates camber thrust during acceleration it will reduce the over contact of tire with roads.

Caster Angle: 0° (Neutral Caster)

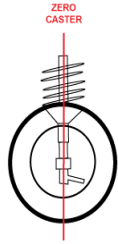

Advantages:

- Better stability
- Better control

Steering axis Inclination / King Pin Inclination: 5° (Positive Inclination)

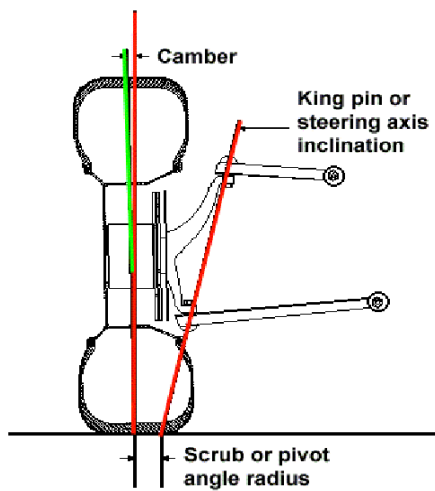

Advantages:

- weight stabilization
- Steady movement of vehicle on a straight line and in turns
- Increases controllability

Advantages of higher scrub radius:

- Control while steering
- Less responsive
- Good for On throttle steering

Toe in angle: 1° (Positive)

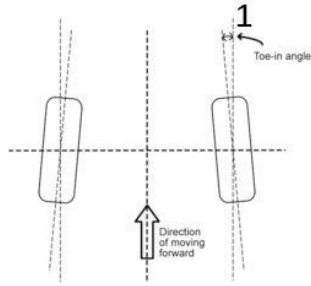

- Creates straight driving characteristics
- Prevent excessive tyre wear
- Increases straight line stability
- Decreases rolling resistance

Maximum Turning angle:

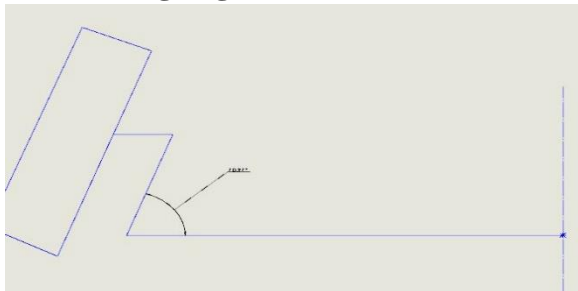

King pin to wheel axle orientation: Neutral

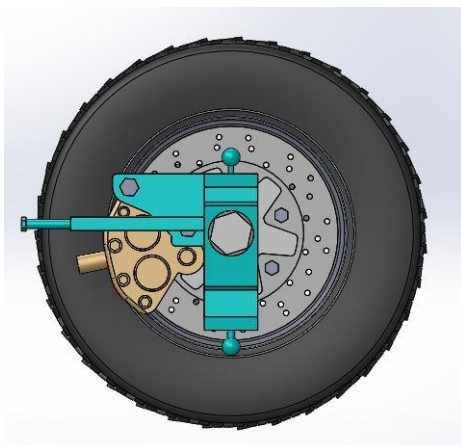

ACKERMAN ERROR: A good steering system must satisfy Ackerman condition. During turns slight variation is unavoidable. Large variation will lead to steering system failure. The below representation shows variation of ackerman for the amount of steering. This was analysed using Suspension analyser giving condition as steering.

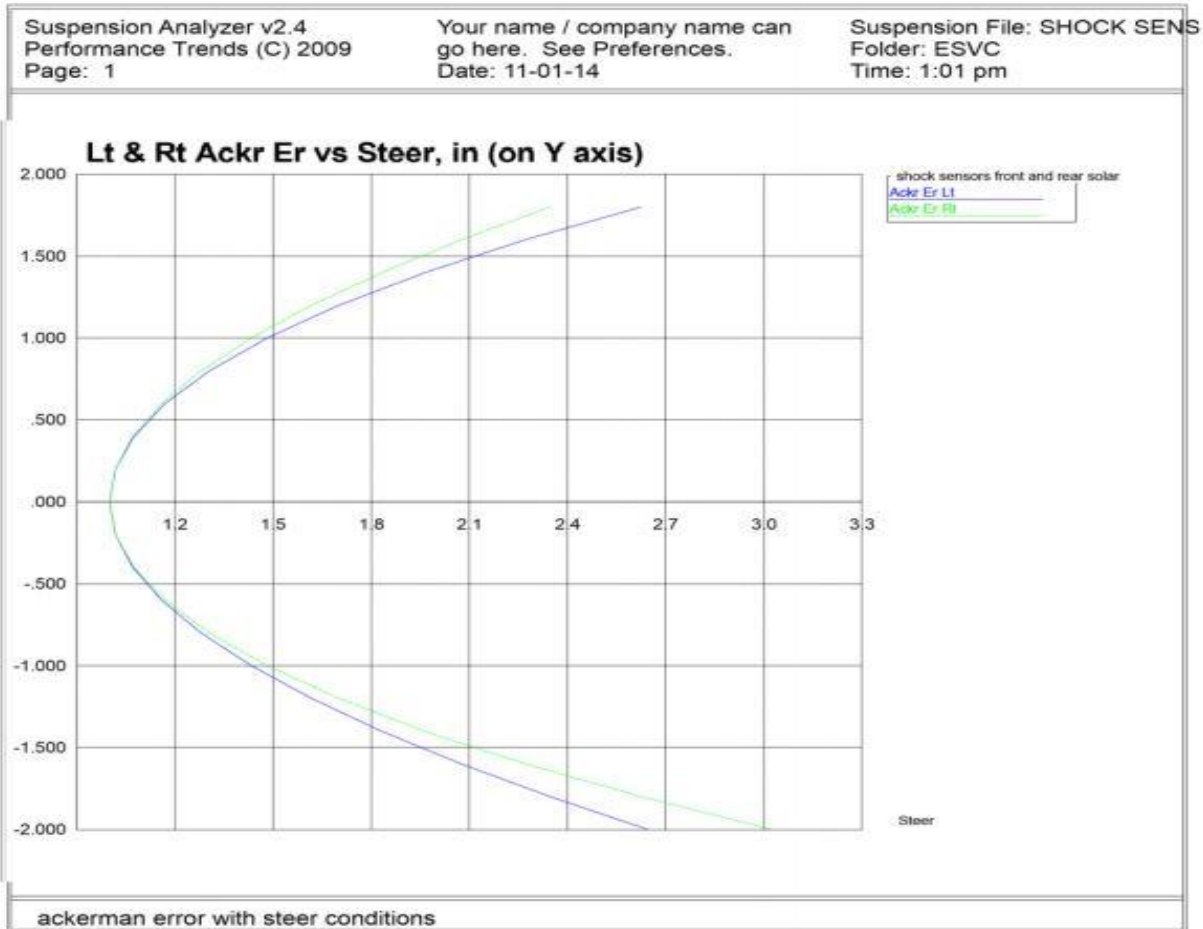

From the above graph its clear that the ackerman variation/error is minimal under steering which represents a good steering system design

STEERING SYSTEM

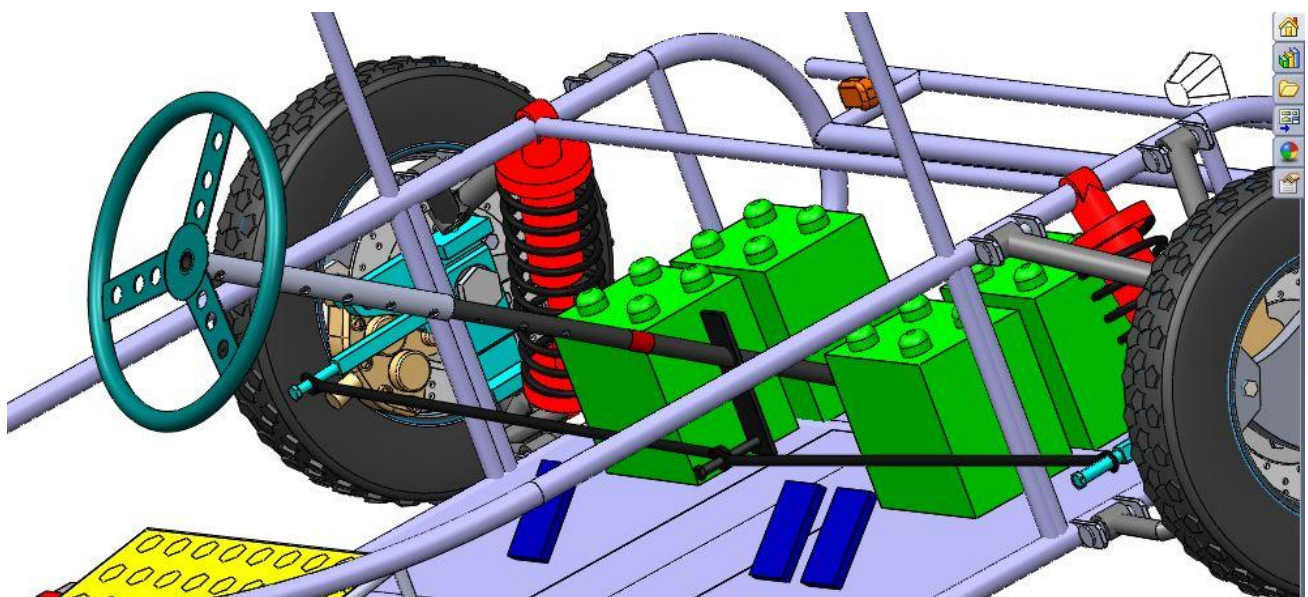

STEERING PARAMETER

Turning radius	140inch
Steering column height	24inch
Steering column length	34inch
Maximum steering angle	71°
Tie rod length	700mm
Short arm length	235mm
Short arm angle	0°
Kingpin inclination	5°
steering type	Pitman arm
Steer travel	90°(Each side)
Steering Ratio	1:1.26