

TGAM

ThinkGear // Features + Technical Specifications

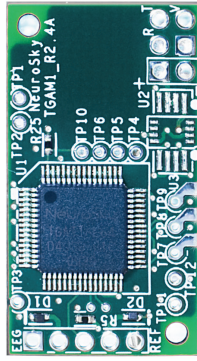

Main Benefit

The TGAM is NeuroSky's primary brainwave sensor ASIC module designed for mass market applications. The TGAM processes and outputs EEG frequency spectrums, EEG signal quality, raw EEG, and three NeuroSky eSense meters attention; meditation; and eyeblinks. With simple dry electrodes, this module is excellent for use in toys, video games, and wellness devices because of its low power consumption, which is suitable for portable battery-driven applications.

Overview

The TGAM module contains the TGAT, the chip that revolutionized an industry, with the Mattel MindFlex being named to TIME Magazine's 100 Best Toys of All Time. With over one million in circulation, it is the world's first EEG (electroencephalography) sensor designed for consumer use. It connects to dry electrodes needed for mass market needs (as opposed to conventional medical wet sensors). Its advanced filtering technology allows for high noise immunity, making the device usable for almost all individuals and in almost all settings.

TGAM: ThinkGear ASIC Module

- Directly connects to dry electrode (as opposed to conventional medical wet sensors)
- One EEG channel with three contacts: EEG; REF; and GND
- Improper fit detected through "Poor Signal Quality" warning from ASIC to reset if off the head for four consecutive seconds, or if it is receiving a poor signal for seven consecutive seconds
- Advanced filtering technology with high noise immunity
- Low power consumption suitable for portable battery-driven applications
- Max power consumption 15mA @ 3.3V
- Raw EEG data output at 512 bits per second

Measures

- Raw brainwave signal
- Processing and output of EEG power spectrums (Alpha, Beta, etc.)
- Processing and output of NeuroSky proprietary eSense meter for Attention, Meditation, and other future meters
- EEG/ECG signal quality analysis (can be used to detect poor contact and whether the device is off the head)
- Eyeblink detection

Physical

- Dimensions (Max) 2.79cm x 1.52cm x 0.25cm
- Weight (Max) 130 mg

UART (serial) standard output interface

- 1200, 9600, 57600 output baud rate
- 8bits
- Parity: none
- Stop Bit: 1

Specs

- 512 bits per second sampling frequency
- 3-100Hz frequency range
- ESD Protection: 4kV Contact Discharge; 8kV Air Discharge
- Max Power Consumption: 15mA @ 3.3V
- Operating voltage 2.97 ~3.63V

Configurable Options AC Noise Filter

- 50 Hz
- 60 Hz

Output & Baud Rate:

- 1200 Baud with Attention, Meditation, EEG Powers (alpha, beta, etc) and Poor Signal Quality
- 9600 Baud with Attention, Meditation, EEG Powers (alpha, beta, etc) and Poor Signal Quality
- 57600 Baud with Attention, Meditation, EEG Powers (alpha, beta, etc) and Poor Signal Quality and Raw EEG wave

To be used with:

Electrodes

- Maximum surface area of ~150mm² (but less surface area is optimal)
- Ag/AgCl, Stainless Steel, Gold, or/and Silver (both solid and plated material works)
- EEG electrode located above the left or right eye on the forehead
- Ground and reference electrodes located behind the ear or at the earlobe
- Have enough pressure to prevent movement, with a minimum of 0.8 PSI

Electrodes

- Length of less than 12 inches, the longer the higher the susceptibility to noise
- Shielding (not necessary for the ground)
- Thinner than AWG28

Mechanical Drawing

The dimensions and major components of the TGAM is shown in the mechanical drawing in *Figure 1*. There are two mounting holes at the upper right and lower left corner. They can be used to secure the TGAM to your system housing.

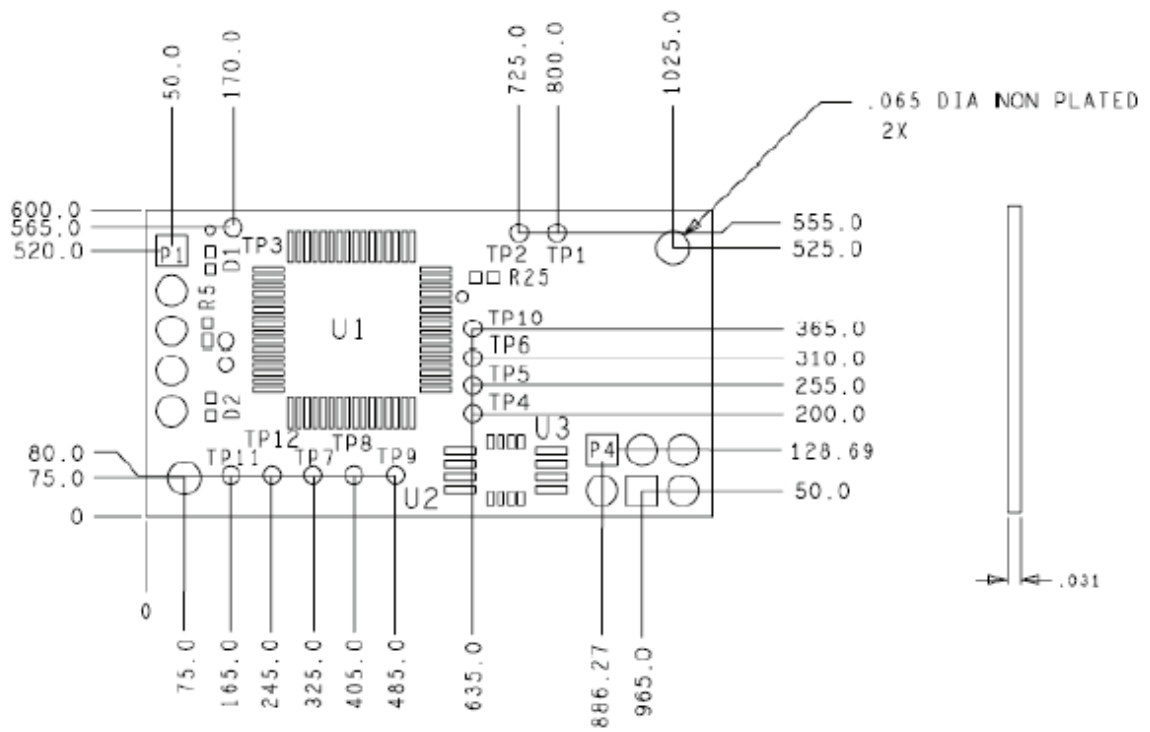

Fig 1 Mechanical Drawing & Board Thickness

Board Layout

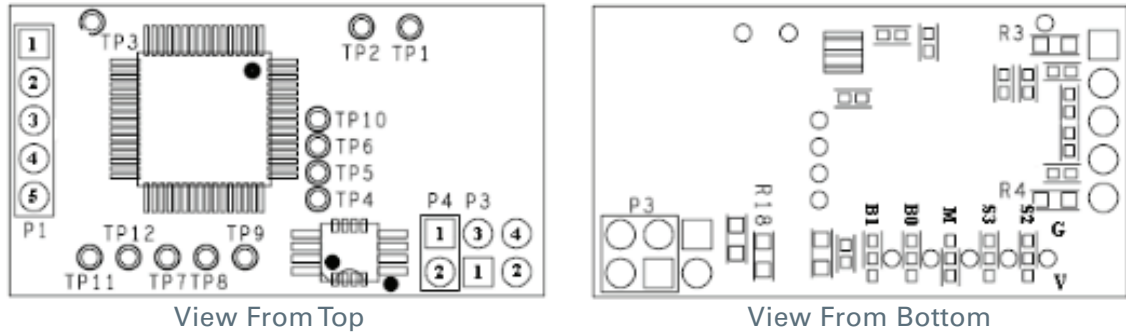

Fig 2 Board Layout Note: Labels in "" indicated on PCB for convenience

Header p1 (Electrode)

- Pin 1 - EEG Electrode "EEG"
- Pin 2 - EEG Shield
- Pin 3 - Ground Electrode
- Pin 4 - Reference Shield
- Pin 5 - Reference Electrode "REF"

Header p4 (Power)

- Pin 1 - VCC "+"
- Pin 2 - GND "-"

Header p3 (UART/Serial)

- Pin 1 - GND "-"
- Pin 2 - VCC "+"
- Pin 3 - RXD "R"
- Pin 4 - TXD "T"

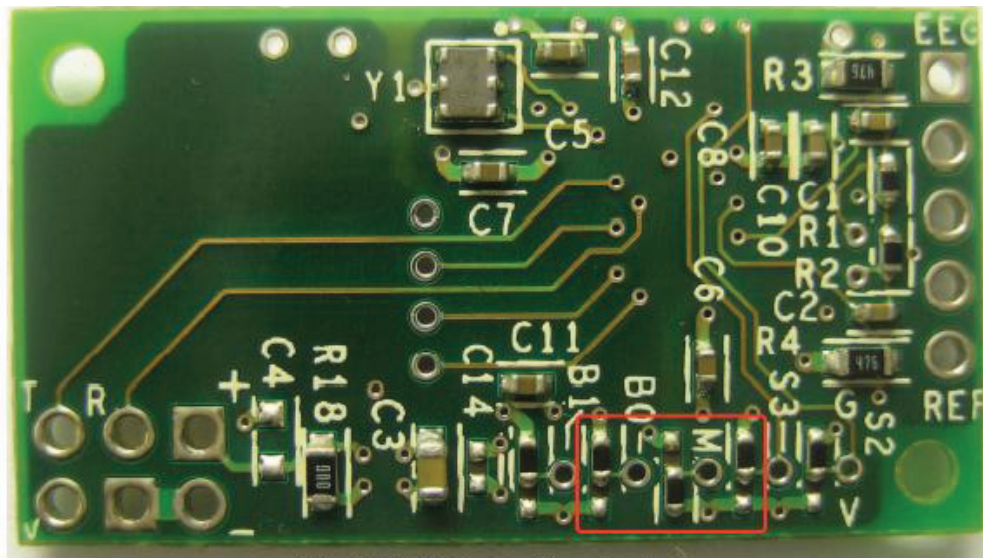
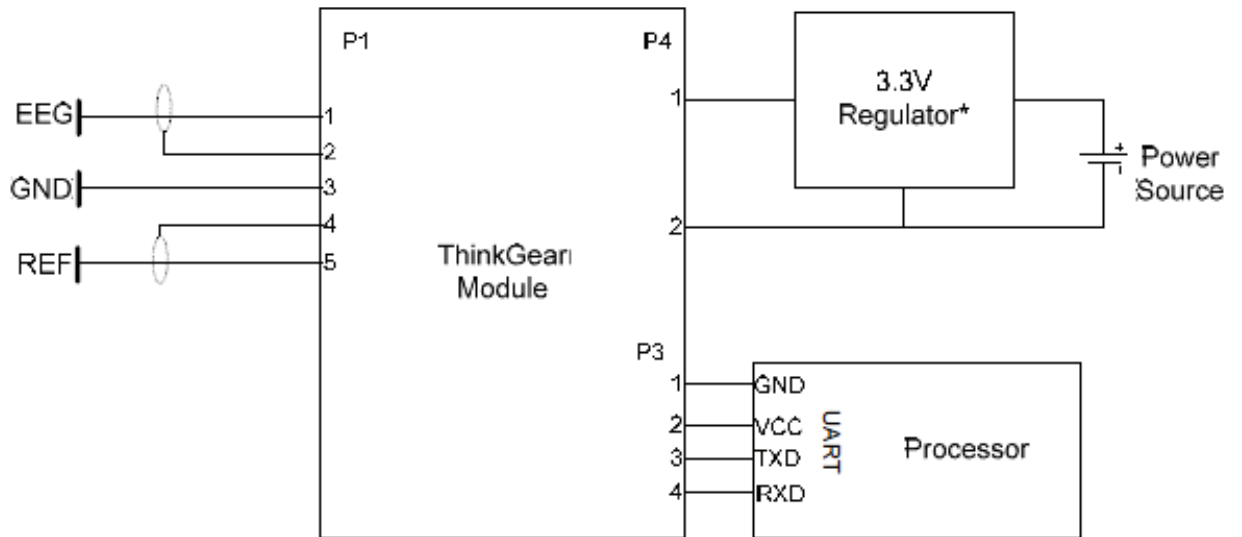

Fig 3 TGAM Configuration Pads * Normal Output mode includes the following output: poor quality value, EEG value, attention value, and meditation value

BR1	BR2	Function
GND	GND	9600 Baud with Normal* Output Mode
GND	VCC	1200 Baud with Normal* Output Mode
VCC	GND	57.6k Baud with Normal* + Raw Output Mode
VCC	VCC	N/A

Example Design

This example design uses 2 AAA batteries to power a TGAM module. Both the EEG and REF electrodes are connected with shielded wires to TGAM, and both of the shielded ground wires are connected to the UART ports of a processor.



*Fig 4 Example Schematic * Normal Output mode includes the following output: poor quality value, EEG value, attention value, and meditation value*