

**TeeBot\_MAX!!  
Simple, Portable ... Folding  
3D printer**

BY:

EMMANUEL ADETUTU

EINDHOVEN

TE NETHERLANDS

 **3DStuffsNL**  
DREAM & CREATE

## TABLE OF CONTENTS

ABOUT The MANUAL.....	2
The design & Specification.....	3
Specification.....	2
List of Materials Needed.....	3
Fastners.....	4
Printed parts.....	11
Smooth & Threaded ROds.....	13
Aluminium frame.....	13
print bed support.....	0
print bed support.....	1
The Build... Part 1 (Main frame).....	4
The Build... Part 2 (Print platform).....	10
The Build... Part 3 (Assembling the X Axis).....	15
The Build... Part 4 (Assembling the Z Axis).....	20
The Build Part 5 (Extruder carriage & belt).....	27
The Build Part 6 (ELECTRONICS).....	32

---

## ABOUT THE MANUAL.

This manual provides you with a visual step by step guide on how to build or assemble TeeBotMax 3D printer. For more build photos please visit my blog, you will have to source the material/parts needed for your build according to the design.

Many will like to start with a complete/ partial kit, you can grab one directly here ([www.3dstuffs.nl/webstore/](http://www.3dstuffs.nl/webstore/))

Please report any error detected in this documentation.

I do all of my drawing in Sketchup and a big fan of the software.

Feel free to get in touch, if you have related questions, collaboration enquiry, or just simply talk 3D printing

For photos and videos of the 3D printer in action, visit my web blog

### How to contact

Twitter : [@teebotmax](https://twitter.com/teebotmax)

Google plus [TeebotMax](#)

Web Blog [tutuemmaWordpress](https://tutuemma.wordpress.com/) (<https://tutuemma.wordpress.com/>)

You can grab a 3D printer kit or needed parts here ([www.3dstuffs.nl/webstore/](http://www.3dstuffs.nl/webstore/))

I hope this guide helps or inspire you in building or assembling your own 3D printer!! If you do please send me a photo of your build.

## THE DESIGN & SPECIFICATION.

The Idea was to design and build a 3D printer which is simple to assemble, easy to move around and travel with, using simple easy to get materials and equally strong and precise.

Many open source designed 3D printer have inspired me in the design of TeeBotMax. Many thanks for sharing: to all the open source developers worldwide over.

\*\*Special thanks to - Josef Prusa (Prusa I3), Emmanuel Gilloz (FoldaRap), Richard Horne (Richrap), Reifsnnyderb (J head Hotend) just to mention a few.

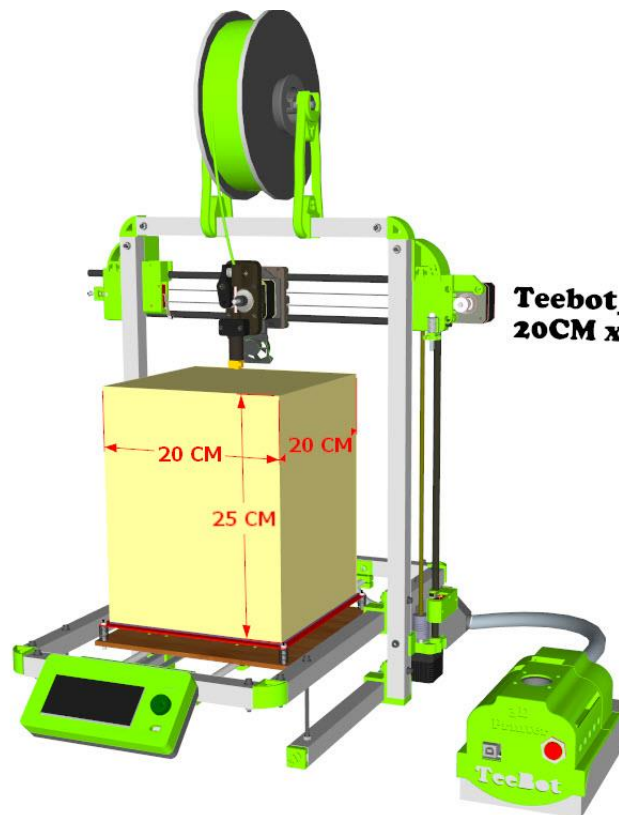

**Teebot\_Max: Large 3D print area  
20CM x 20CM x 25CM**

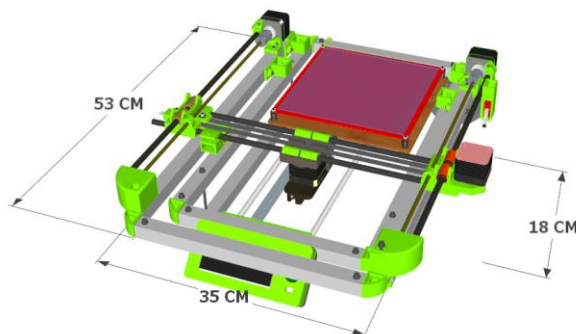

**TEEBOTMAX FOLDED**

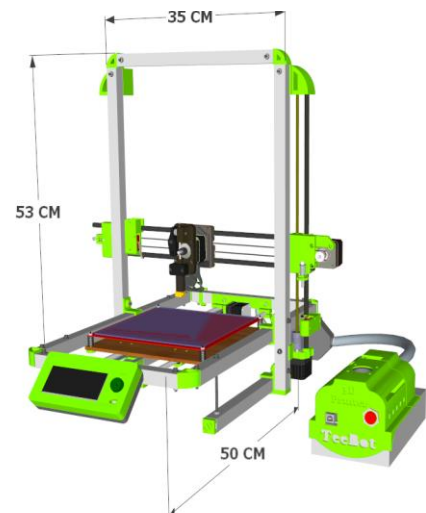

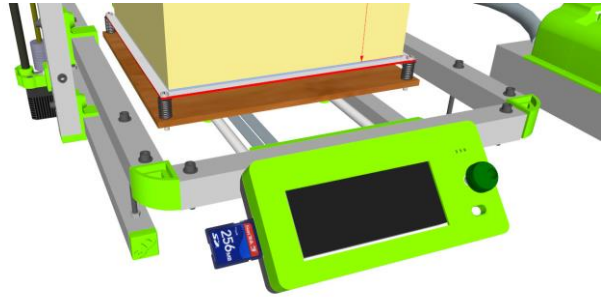
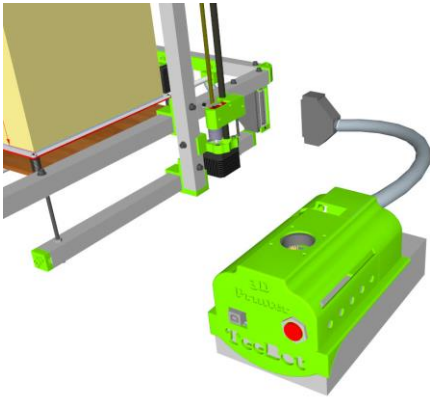

---

## SPECIFICATION.

- **Build Cost:** 350 ~500 Euro (Depending on source of materials/parts)
- **Build time:** Approximately 1 full day.
- **Filament type:** Compatible with 3mm/1.75mm, ABS/PLA/Flexible\_filament
- **Print Speed:** 120mm/s
- **Nozzle:** J head type 0.4mm
- **Tested Layer height/resolution:** 0.1mm
- **Power supply:** 12v 20a
- **Weight:** ~7kg

## LIST OF MATERIALS NEEDED.

SN	Material	Description	Quantity	Note/Source
1	All Printed plastic parts	You can print or Buy	1 set	
2	Extruder kit (TeeStruder)	Direct drive extruder.	1 set	
3	Printer Frame aluminum	20mm square	3.4 meters	
4	8mm Smooth rods	Used in all Axis	3 meters	
5	Linear bearing Lm8uu	8 mm	11 Pcs	
6	Springs Heatbed exturder.	O.D: 10mm	6 Pcs	
7	624 Bearing	Used as idlers	5 Pcs	
8	Threaded rods	5mm diameter	1 meter	
9	Flexible shaft coupler	5mm X 5mm	5 Pcs	
10	Heated Bed	12v Heated bed	1 Pcs	
	Print Glass/ mirror	20cm x 20cm	1pcs	
11	Complete Electronics Board	Ramps 1.4	1 Set	
12	Cooling Fan	4Cm X 4Cm X 1Cm	2 Pcs	
13	Power Supply	12v with min of 15A	1 Set	
14	Hotend	J head type	1 Set	
15	100k Thermistor.	Heated_bed & extruder.	2 Pcs	
16	Limit switch	One for each axis	3	
17	Ramps LCD controller	Print without a PC/Laptop	1	
18	GT2 Timing Belt	Drive's the X & Y axis	2 meters	
19	Pulley	Gt2 Pulley	2	
20	Stepper Motors	Nema 17	5 Pcs	
	Binder Clips	standard	4 Pcs	

For a complete detail list of fasters please see the section below

---

## FASTNERS.

### Footer

- M8 x 110mm (4pcs)
- M8 Nuts (12pcs)
- M8 Washer (16pcs four on each)

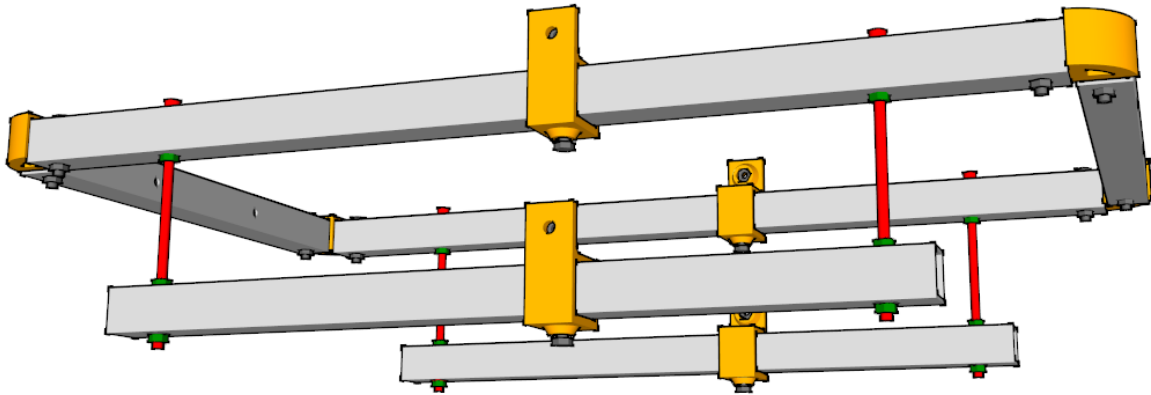

### Z Axis Top

- M5 x 60mm (2pcs)
- M5 Nut (2pcs)
- M4 x 25mm (2pcs)
- M4 nut (2pcs)
- M4 washer (4pcs)

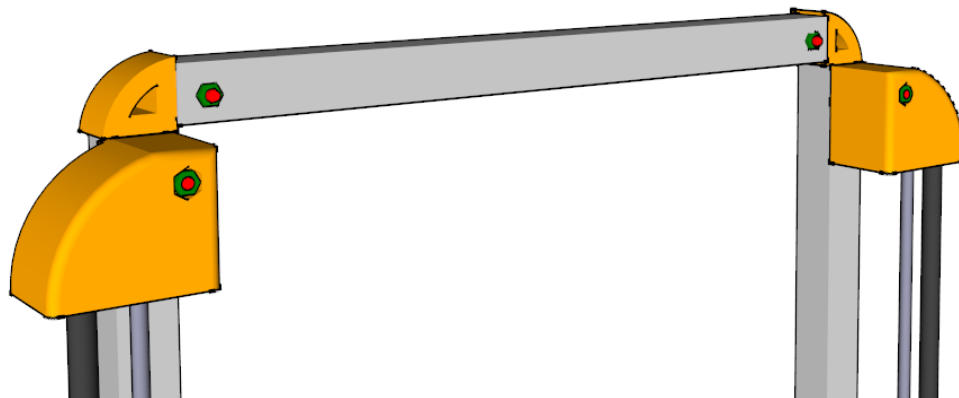



## Z Axis Bottom

- M4 x 30mm (4pcs)
- M4 washer (4pcs)
- M4 Nut (4pcs)

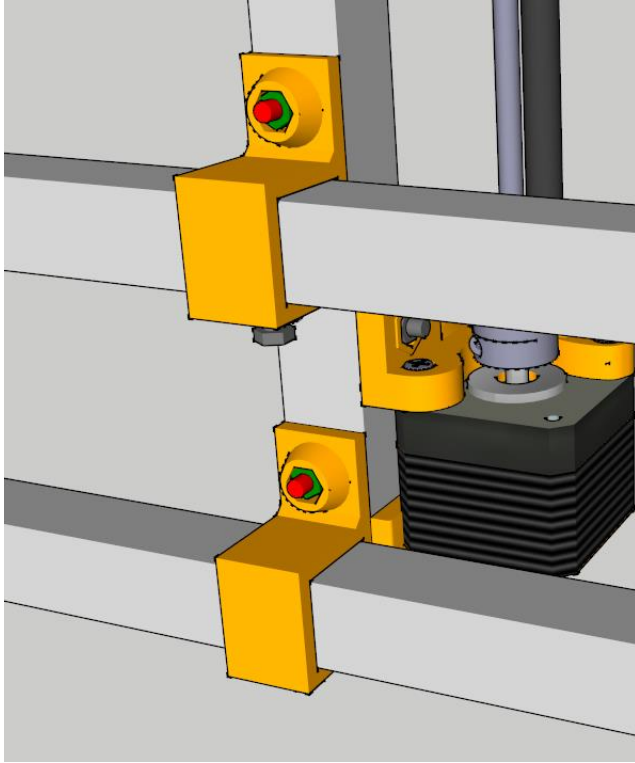

## Z Axis lock

- M4 x 10mm (4pcs)
- M4 nuts (4pcs)

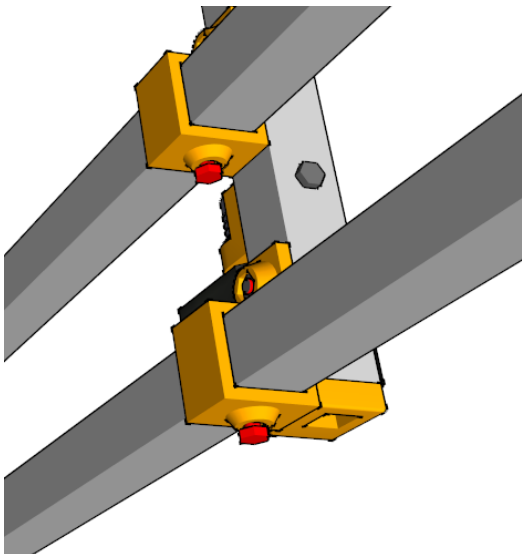

## Z Motor Holder

- M4 x 30mm (2pcs)
- M4 Nuts (2pcs)
- M4 Washer (2pcs)
- M3 x 10mm (6pcs)

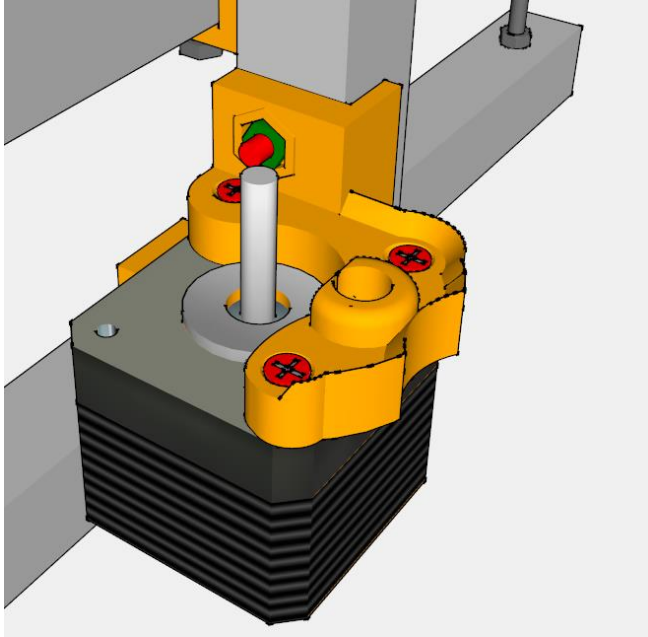

## Four corner

- M4 x 25mm (8pcs)
- M4 Nuts (8pcs)
- M4 washers (16pcs)

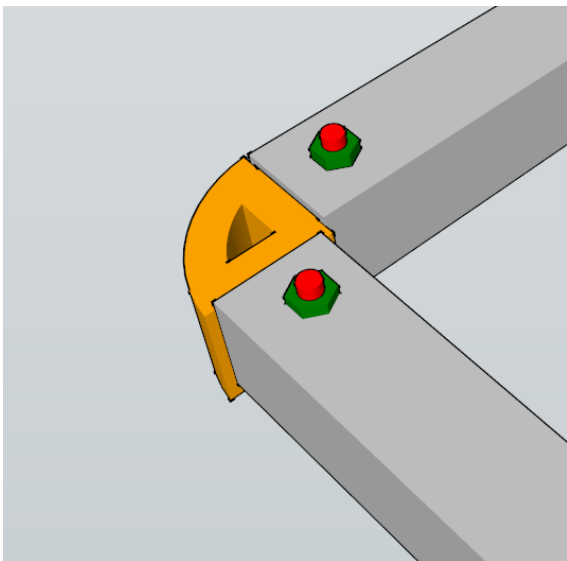

## X Axis

- M3 x 10mm (3pcs)
- Flat head M4 x 25mm (2pcs)
- M4 Nut (2pcs)
- M3 x 20mm (1pcs)
- M3 nut (2pcs)

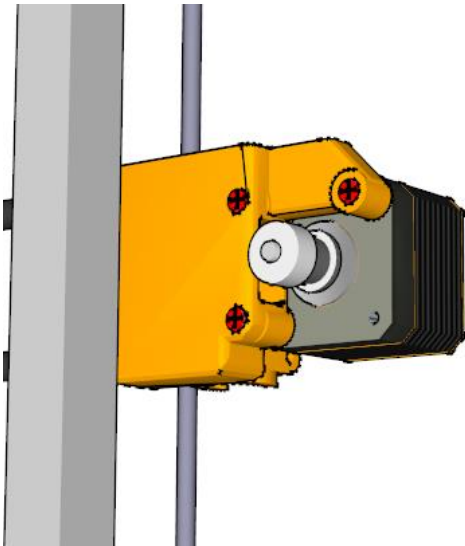
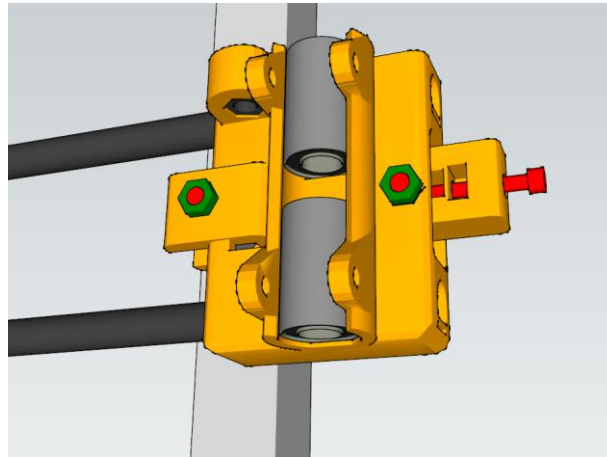
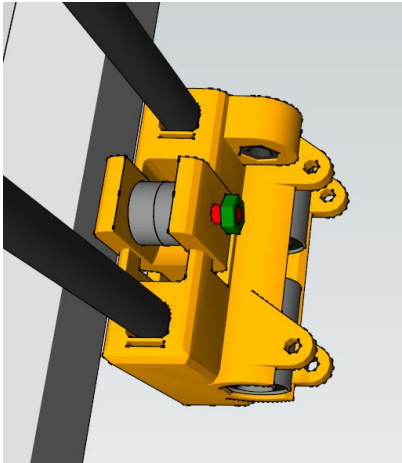

## Y axis

- M4 x 30mm (1pcs)
- M4 Nuts (1pcs)
- M3 x 30mm (4pcs)
- M3 nuts (4pcs)
- M3 washer (8pcs)
- M3 x 10mm (3pcs)

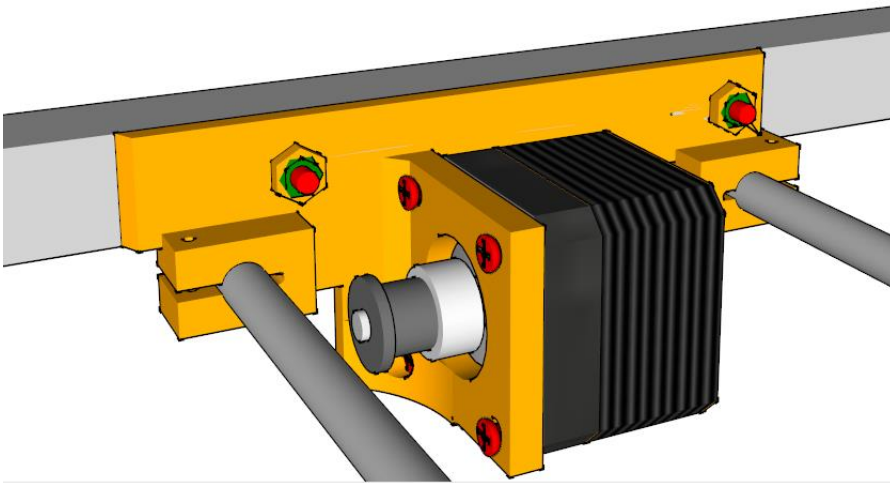
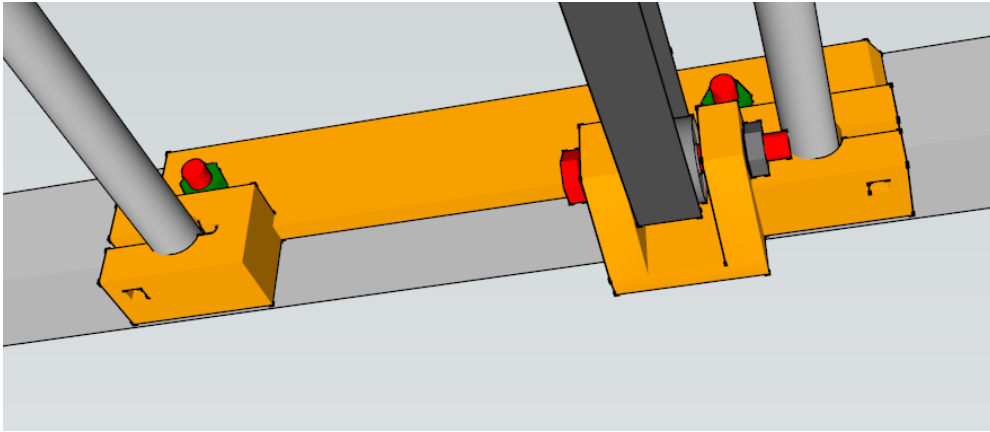

## Heat Bed

- M3 x 30mm (4pcs)
- M3 nuts (8pcs)
- M3 x 16mm (8pcs)
- M3 washer (8pcs)
- M3 nuts (8pcs)

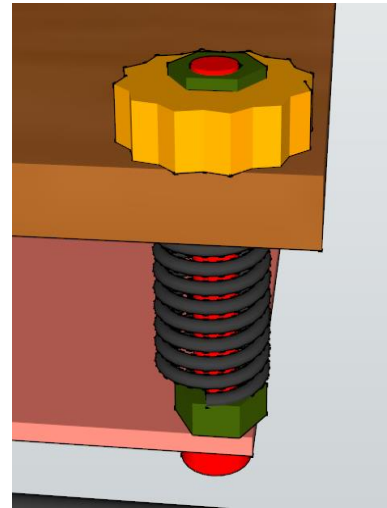
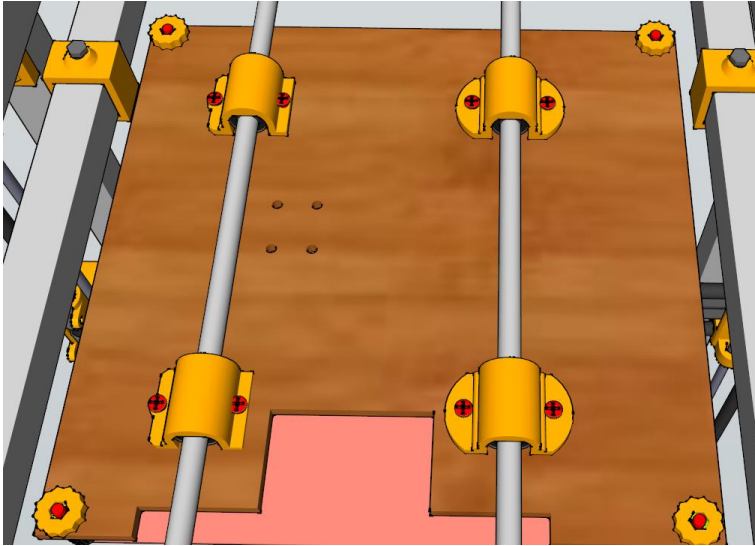

## X Axis carriage

- M3 x 20mm fan (2pcs)
- M3 washer (4pcs)
- M3 nut (2pcs)
- M4 x 25mm (4pcs) mount
- M4 nuts (4pcs)
- M 5 nuts (2pcs) X\_axis lift

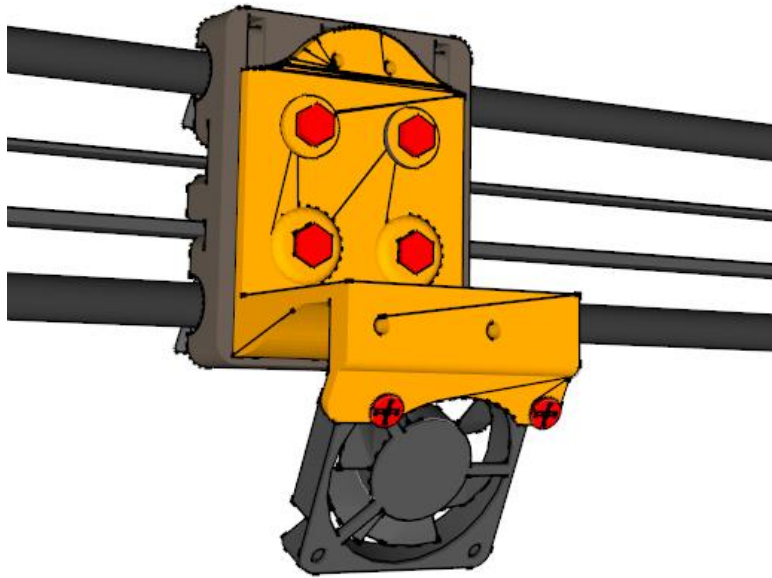

PRINTED PARTS.

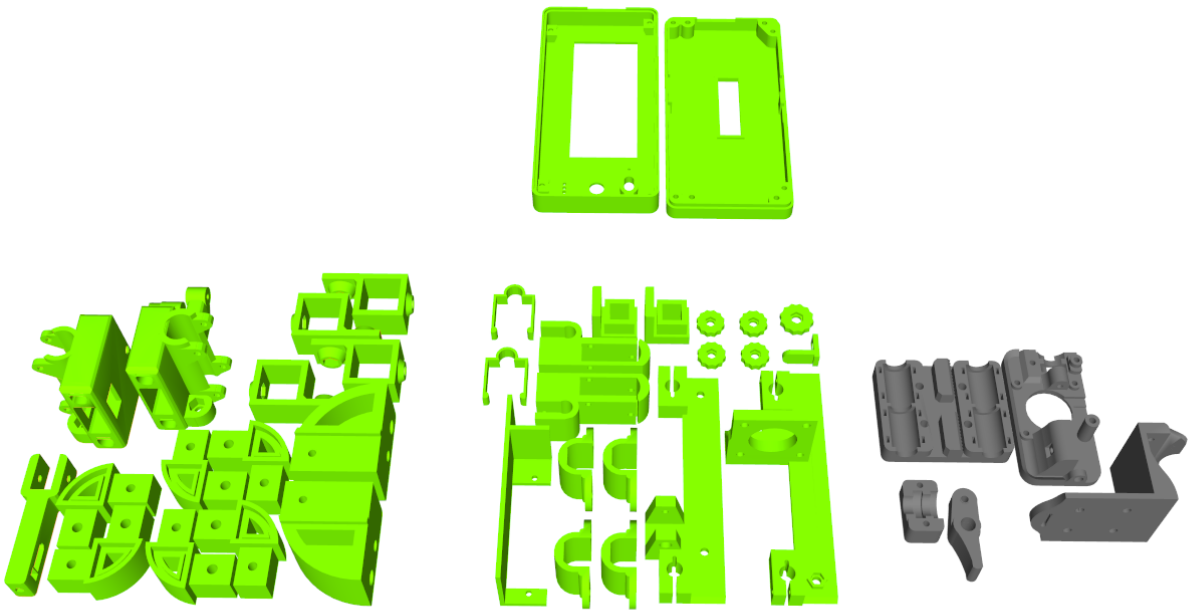

1 x X\_Ends



1 x X\_Motor\_Ends



1 x X\_Motor\_Iddler



1 x  
Z\_Rod\_Holder\_R

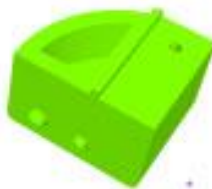

1 x  
Z\_Rod\_Holder\_L



1 x  
SD\_RAMPS\_CASE



4 X Connectors



6 X Corner



1 X Y\_End\_Motor



1 X Y\_Idler



4 X Foot\_Cap



2 X Z\_Foot\_Cap



4 X Bearing\_Holder



4 X Bed\_Knob



1 X Smart\_Zlevel



1 X Z\_End\_Motor



1 set Limit\_Holder



8 X Cable\_Holder



### SMOOTH & THREADED RODS.

- 2x Smooth rod  $\varnothing 8$  x 460mm
- 4x Smooth rod  $\varnothing 8$  x 420mm
- 2x Threaded rod M5 x 400mm

### ALUMINIUM FRAME.

The frame pipes are cut out of 2cm square tubing. 9 Pcs

- A. 25cm x 2Pcs {short main frame}
- B. 46cm x 2Pcs {Long main frame}
- C. 50cm x 2Pcs {Long folding arms}
- D. 30cm x 1Pcs {Folding arms connect}
- E. 36cm x 2Pcs {Foot pipes}

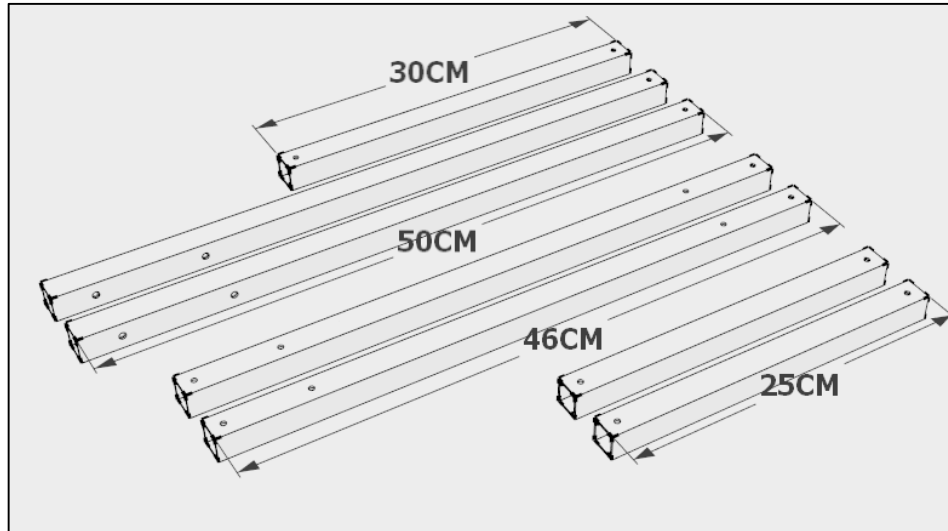

## Short main frame

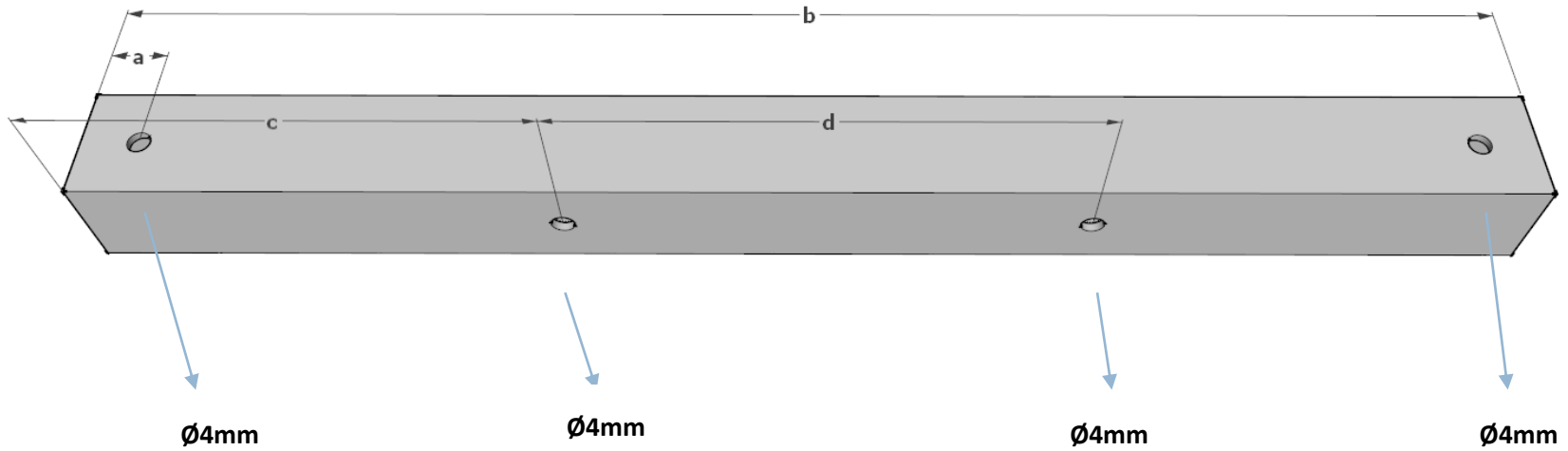

a = 1.0cm

b = 25.0cm

c = 8.2cm

d = 9.2cm

All hole size 4mm diameter

Drawn By: Emmanuel Adetutu

Project: TeeBotMax 3D printer

Part: Main frame

Quantity: 2

### Long main frame

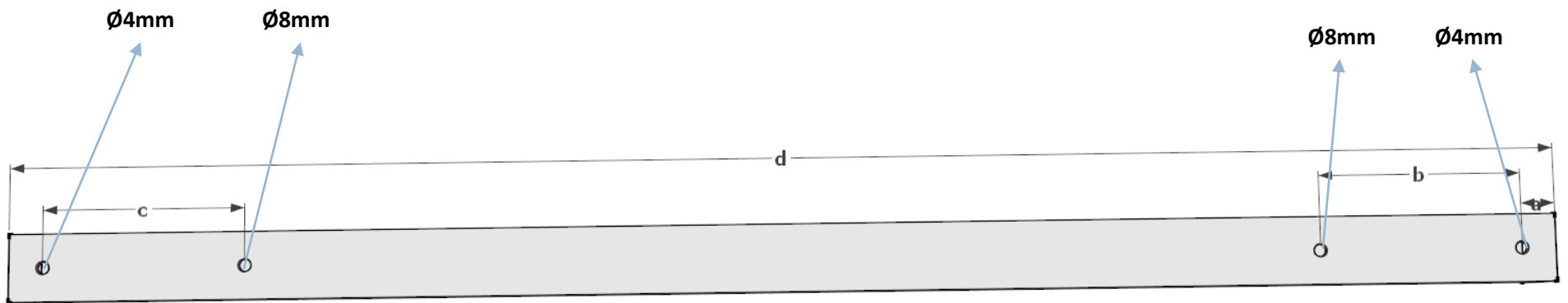

- a = 1.0 cm
- b = 6.0 cm
- c = 6.0cm
- d = 46.0cm

Project: TeeBotMax 3D printer
Part: Main frame
Quantity: 2

## Long folding arms

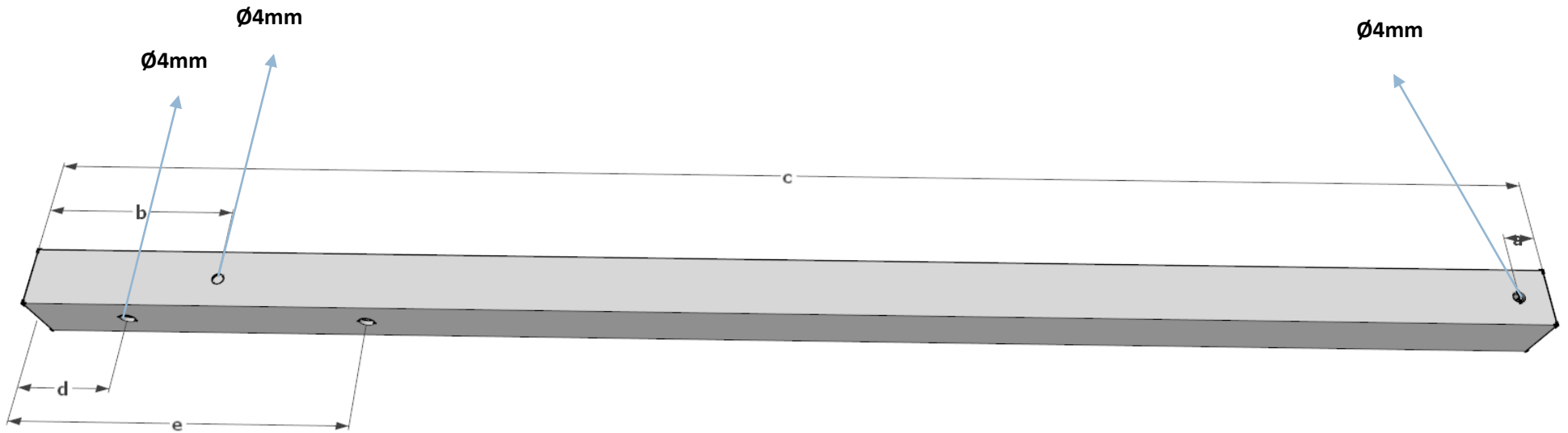

a = 1.0cm

b = 6.2cm

c = 50.0cm

d = 3.0cm

e = 11.0cm

Drawn By: Emmanuel Adetutu
Project: TeeBotMax 3D printer
Part: Z axis frame
Quantity: 2

### Short folding arms

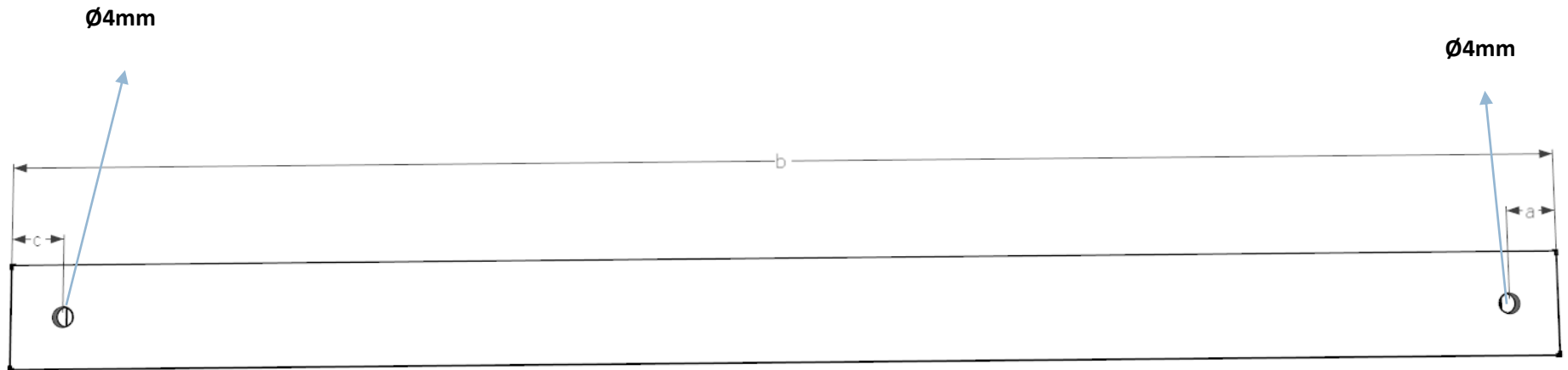

$a = 1.0\text{cm}$

$b = 30.0\text{cm}$

$c = 1.0\text{cm}$

Drawn By: Emmanuel Adetutu

Project: TeeBotMax 3D printer

Part: Z axis frame top

Quantity: 1

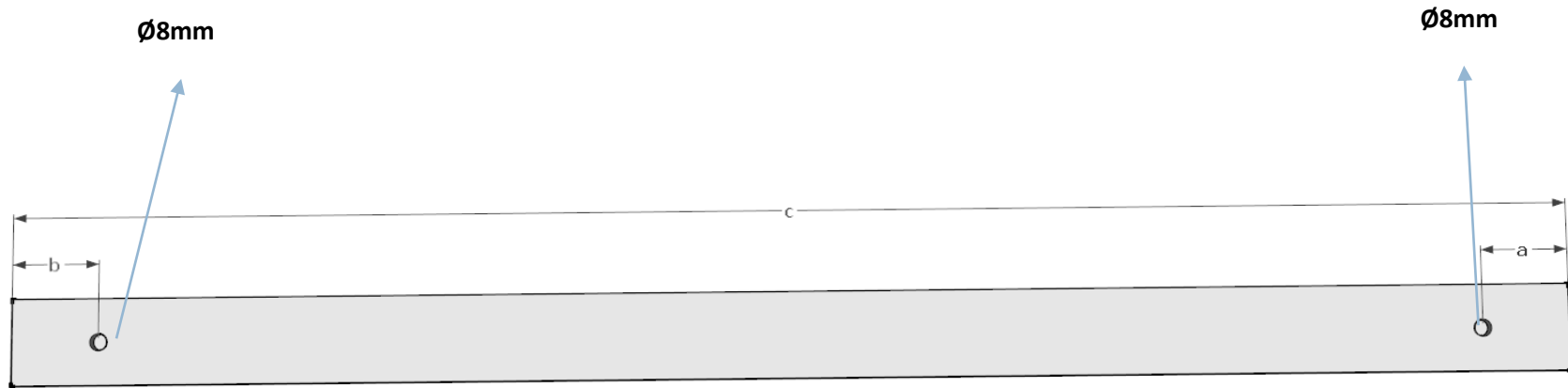

$a = 2.0\text{cm}$

$b = 2.0\text{cm}$

$c = 36.0\text{cm}$

The hole size 8mm diameter

Drawn By: Emmanuel Adetutu

Project: TeeBotMax 3D printer

Part: footer

Quantity: 2

# PRINT BED SUPPORT

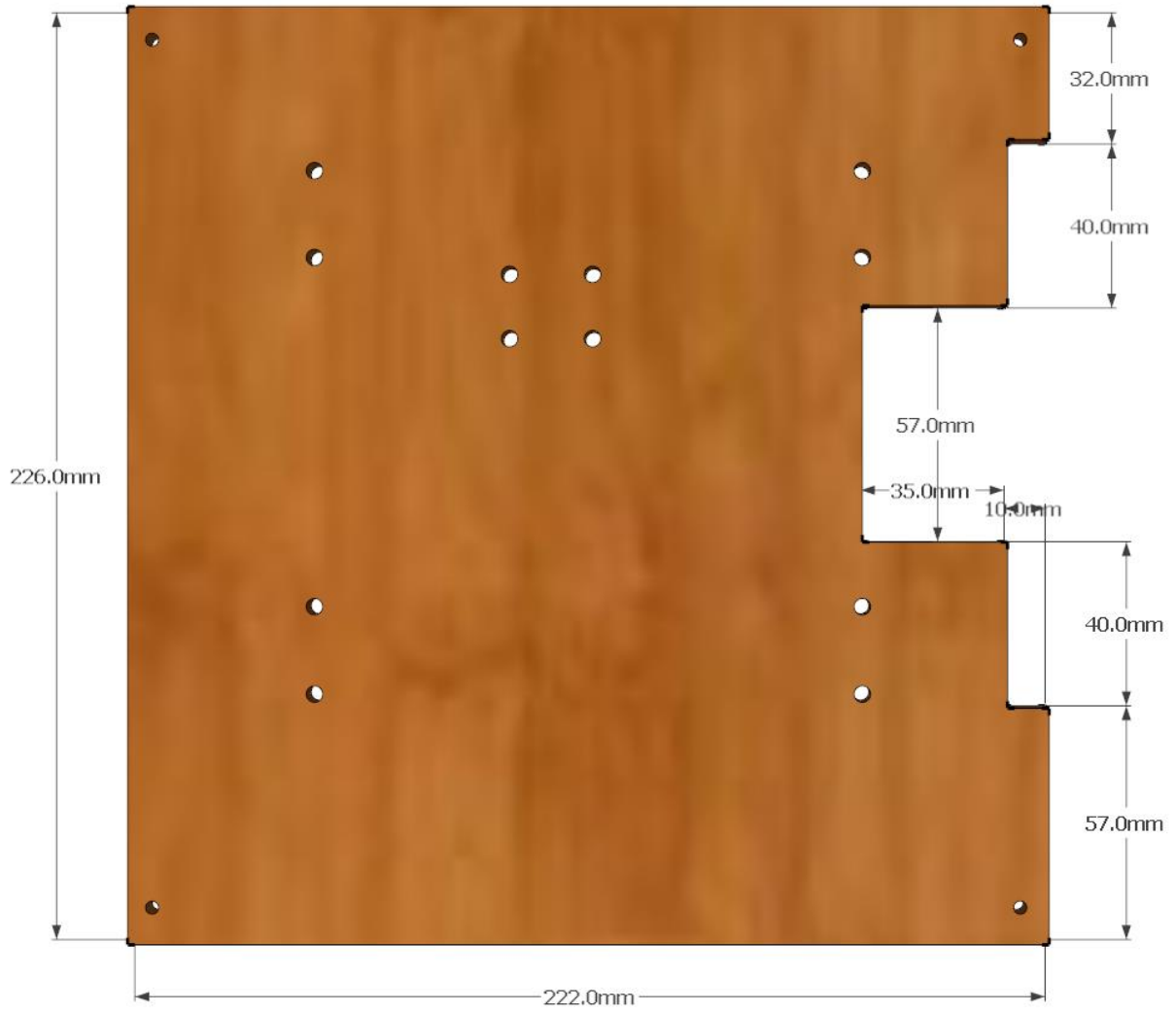

PRINT BED SUPPORT

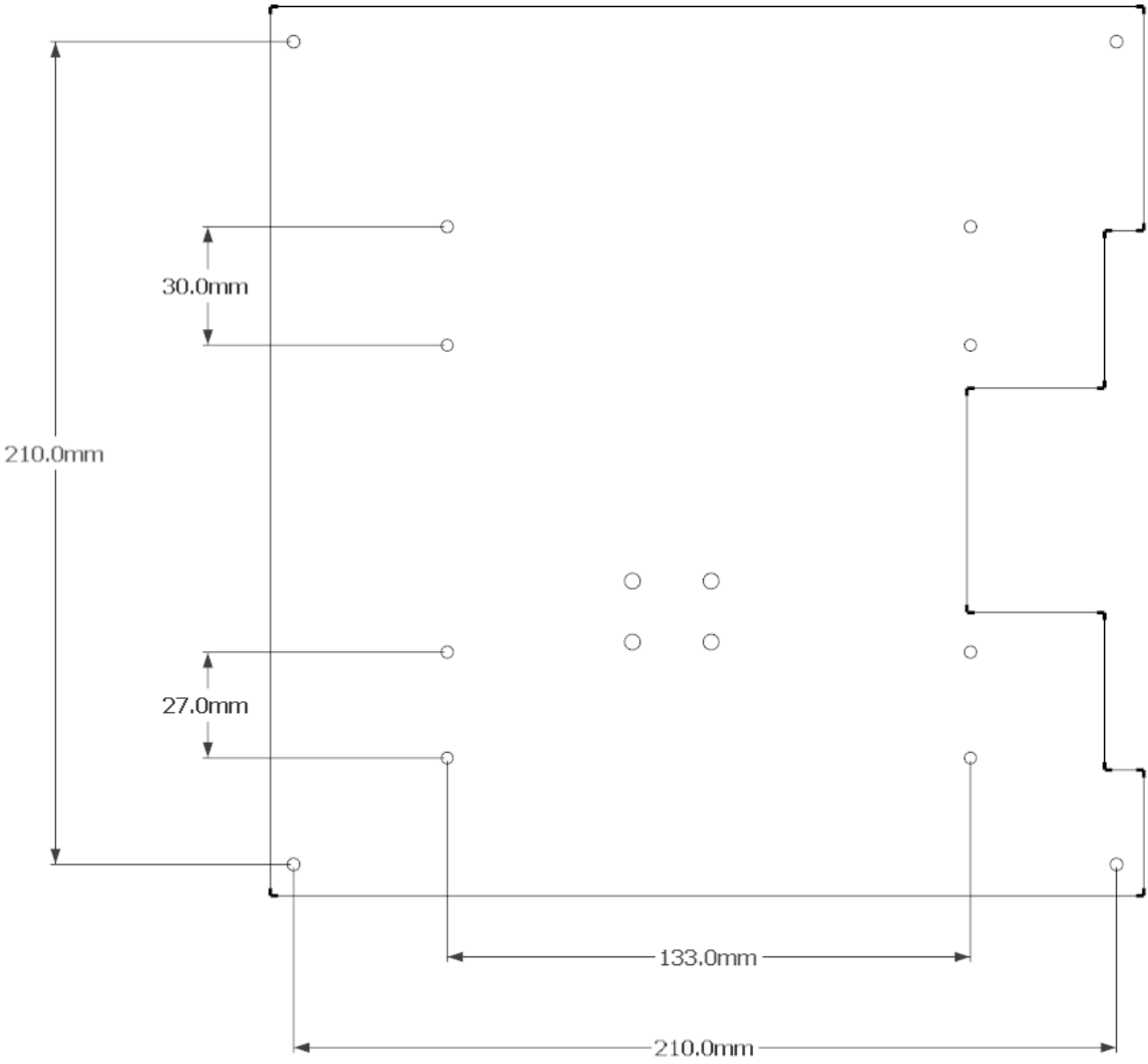



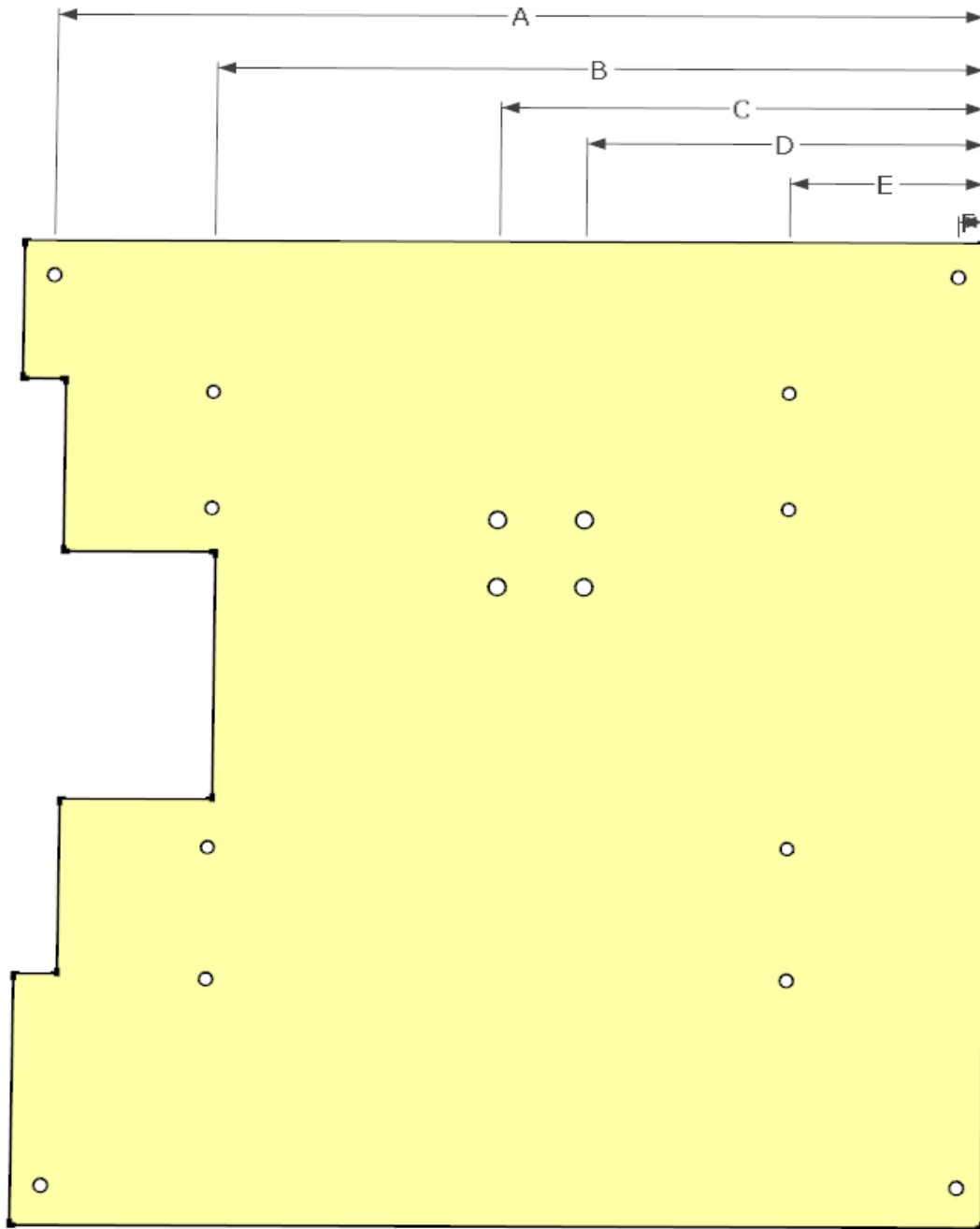

A = 215mm

B = 178mm

C = 112mm

D = 92mm

E = 45mm

F = 6mm

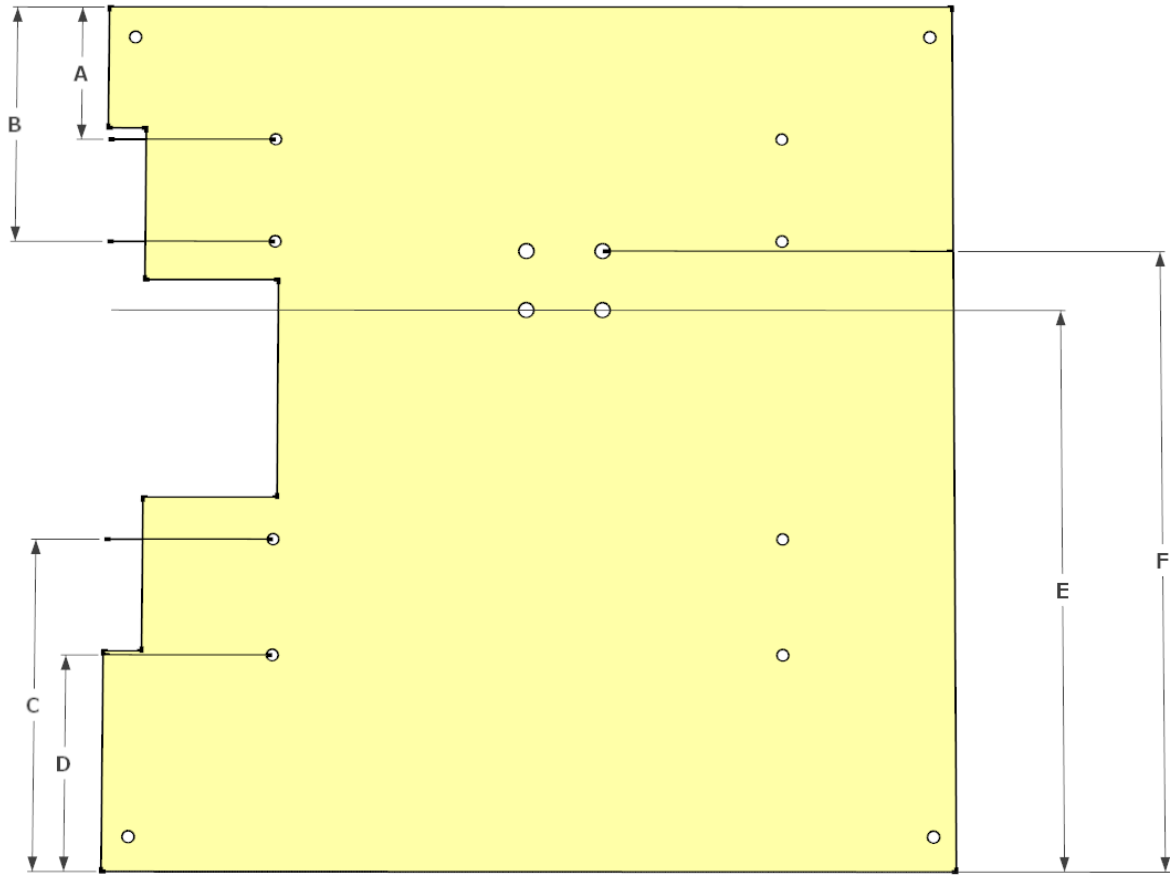

A = 35mm

B = 62mm

C = 86mm

D = 56mm

E = 146 mm

F = 162mm

---

## THE BUILD... PART 1 (MAIN FRAME)

1. Insert 2pcs of the 4m nuts in one of the connectors as shown below, repeat for all 4 connector.

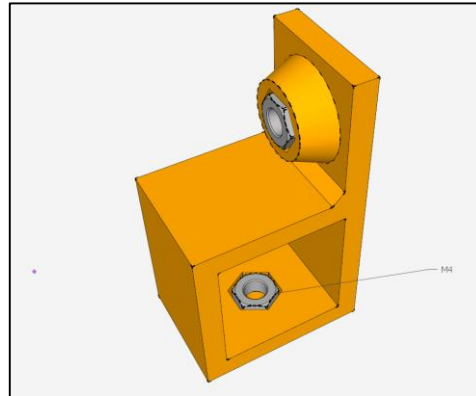

**4 X**

2. Insert 2 of the connectors into the 46cm and 36cm pipe.

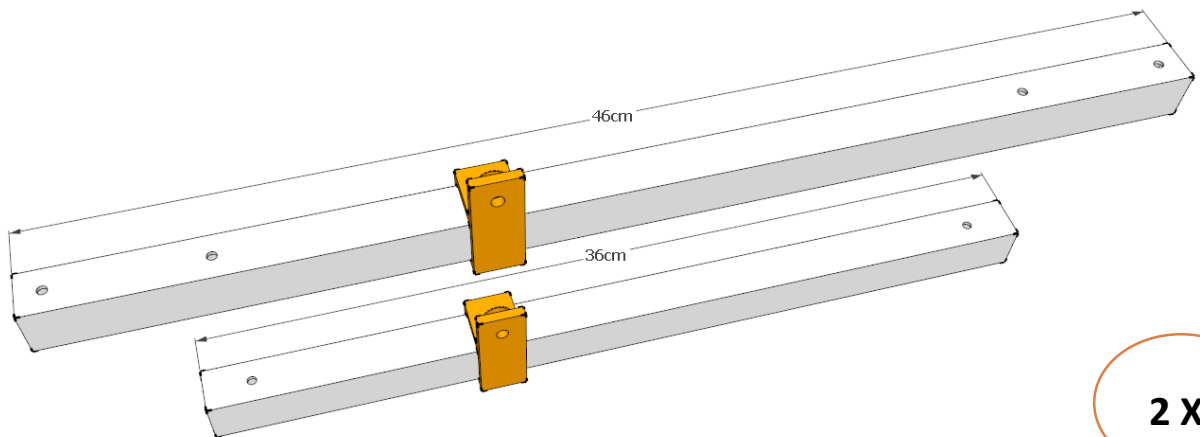

**2 X**

3. Thread the M8 bolt into the pipes using 3 nuts and 4 washers. Ensure that the distance between the pipes is 6cm.

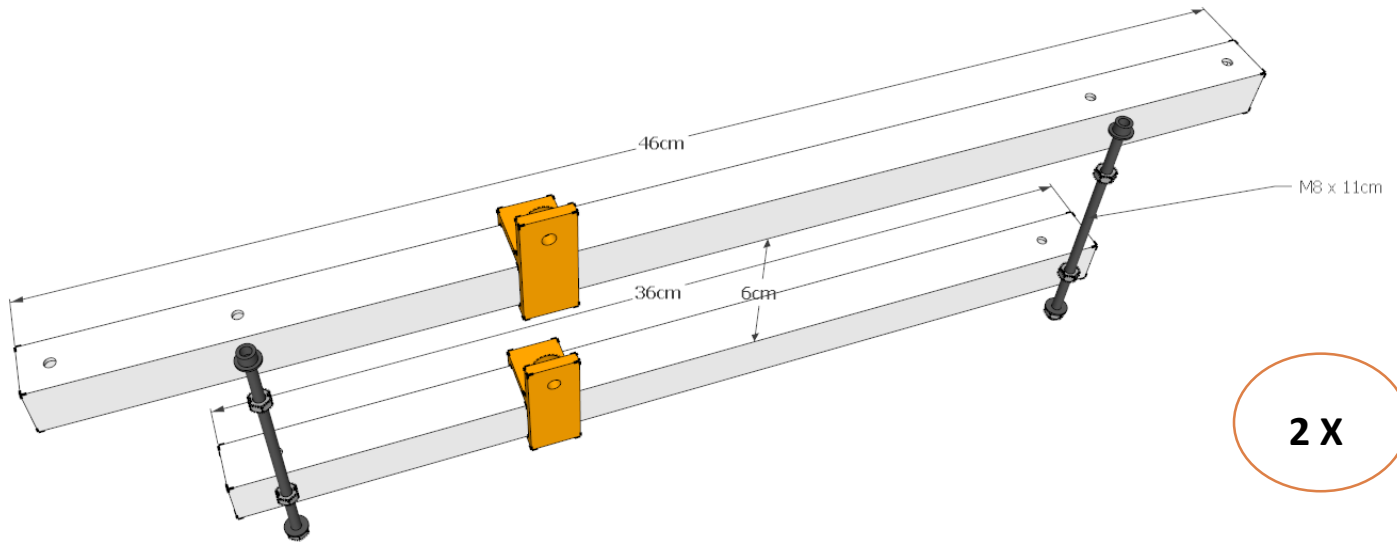

4. Using M4 x 10mm bolts lock the plastics in place 25cm from the tip of the longer pipe and 20cm from the smaller one as shown below.

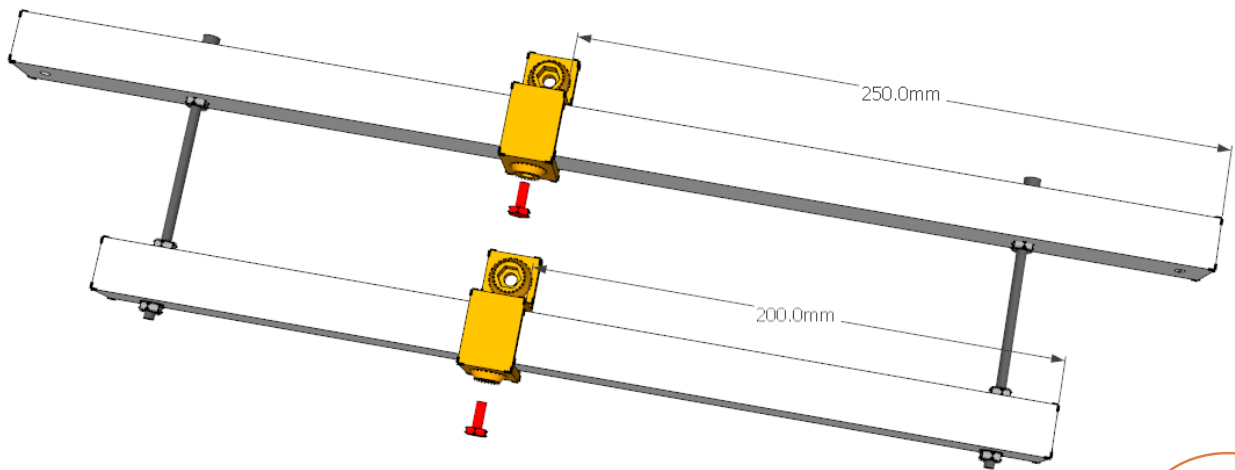

5. Assemble the Y Axis idler as shown below, using the 624 bearing, one M4 bolt and 2 M3 bolts.

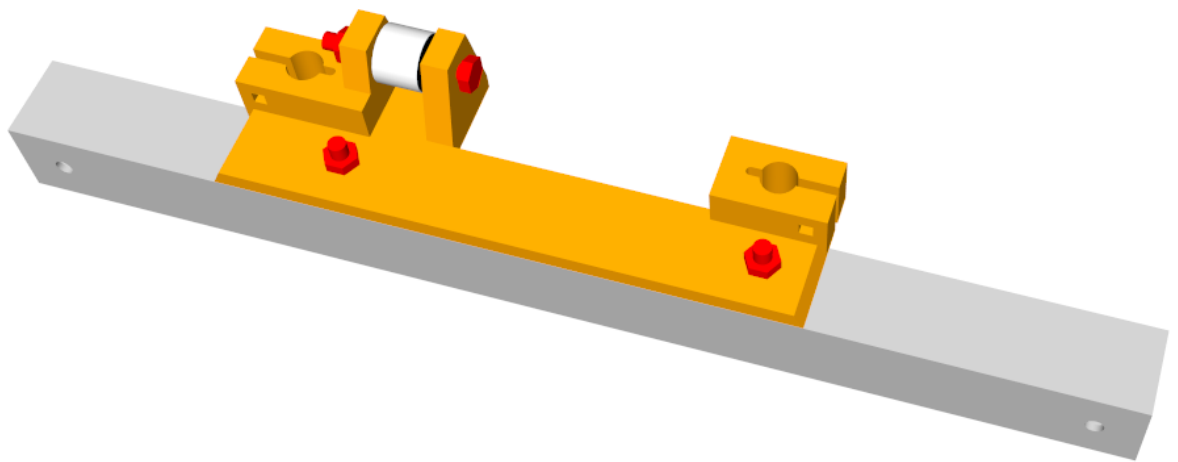
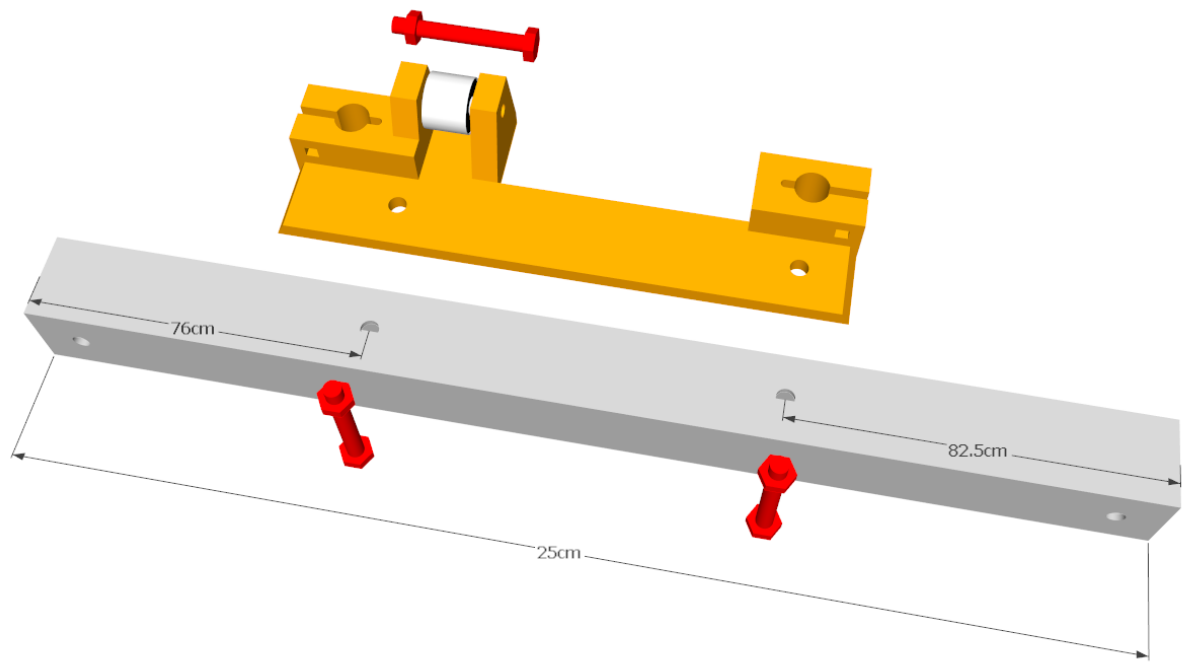

6. Assemble the Y Axis Motor end as shown below, using the stepper motor, M3 x 30mm and pulley

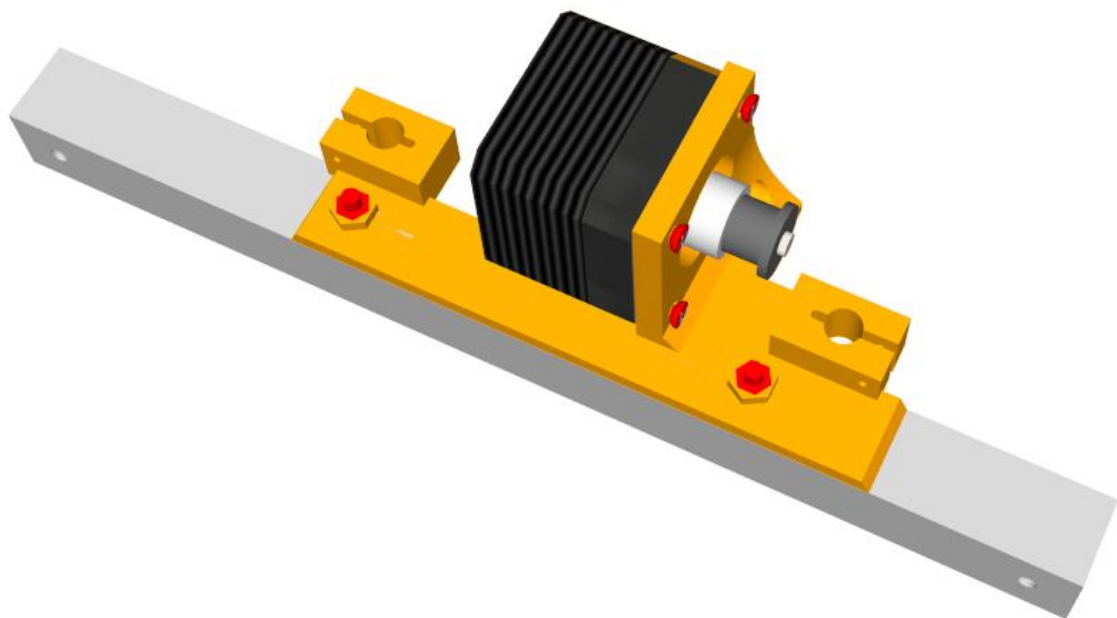
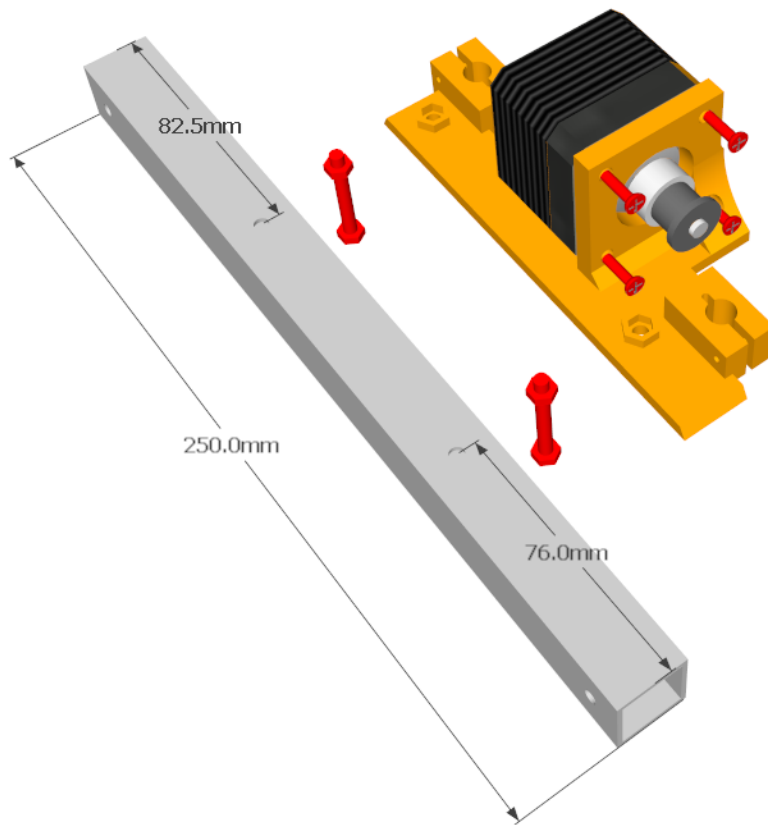

7. Insert the corner piece into each end of the Y Axis frame pipes using the M4 x 25mm bolts, washers and nuts.

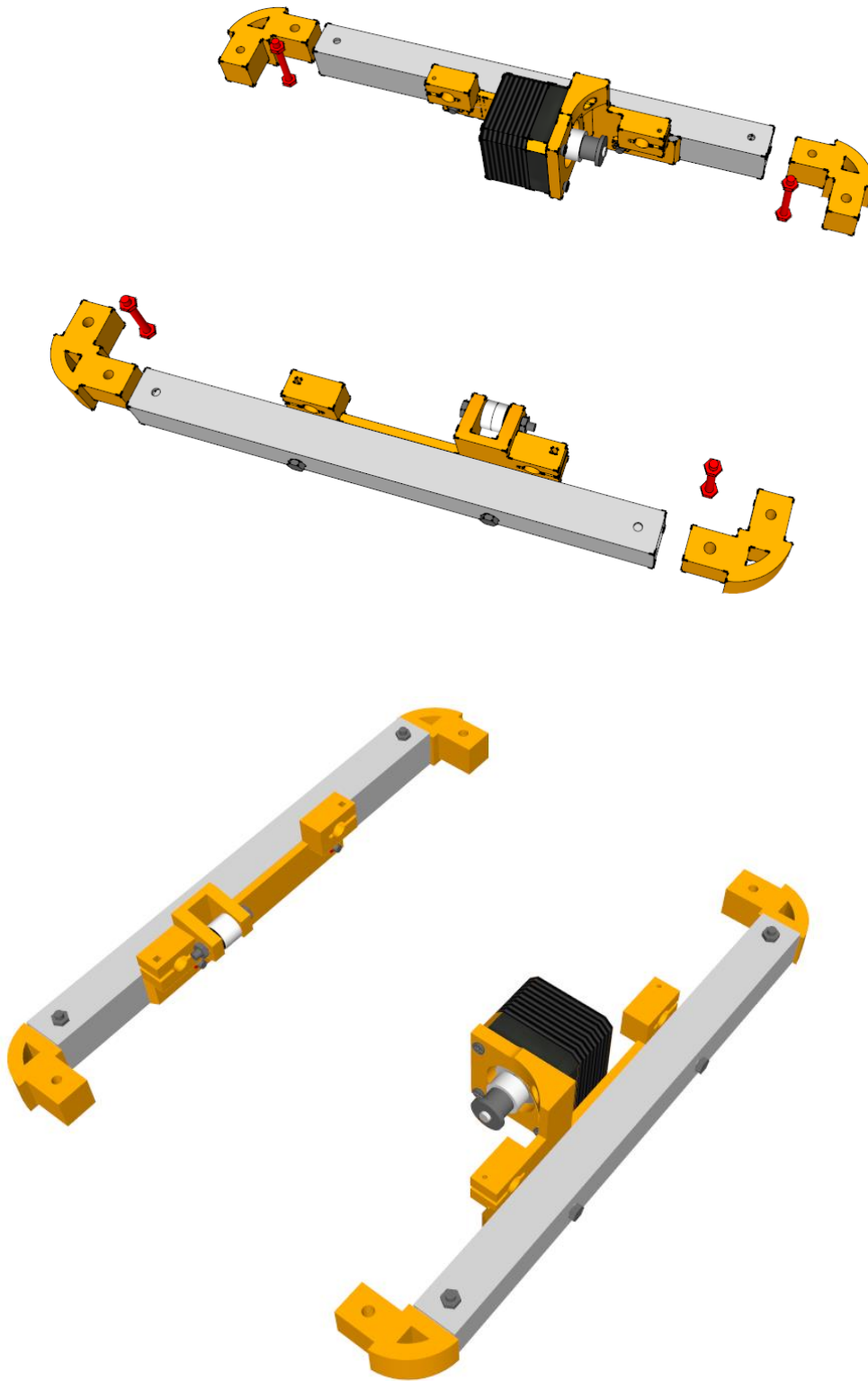

8. Connect all four parts together using 4 M4 x 25 bolts, washers and nuts

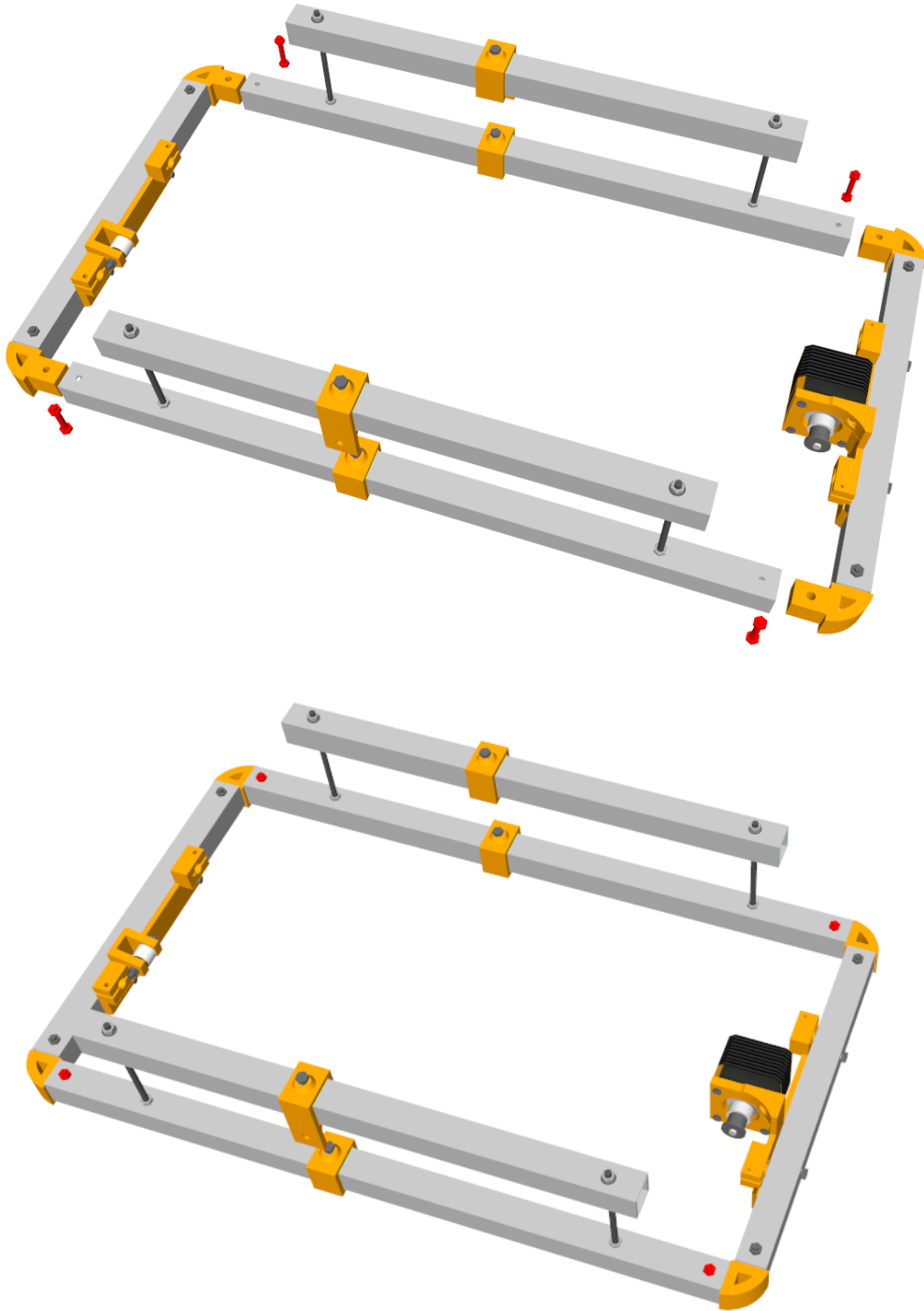

Congrats if you made it this far. !! This completes the build of the main frame make sure all corner joints are tightly fitted and squared. The feet might wobble/shake a bit it is fine, when the Z axis frame is installed it will fix this.



---

## THE BUILD... PART 2 (PRINT PLATFORM)

1. Using 4 Lm8uu linear bearings and the 46 cm smooth rods, Insert the rods half way and then insert the bearing. You might need an 8mm drill set in reverse motion to make the holes fit.

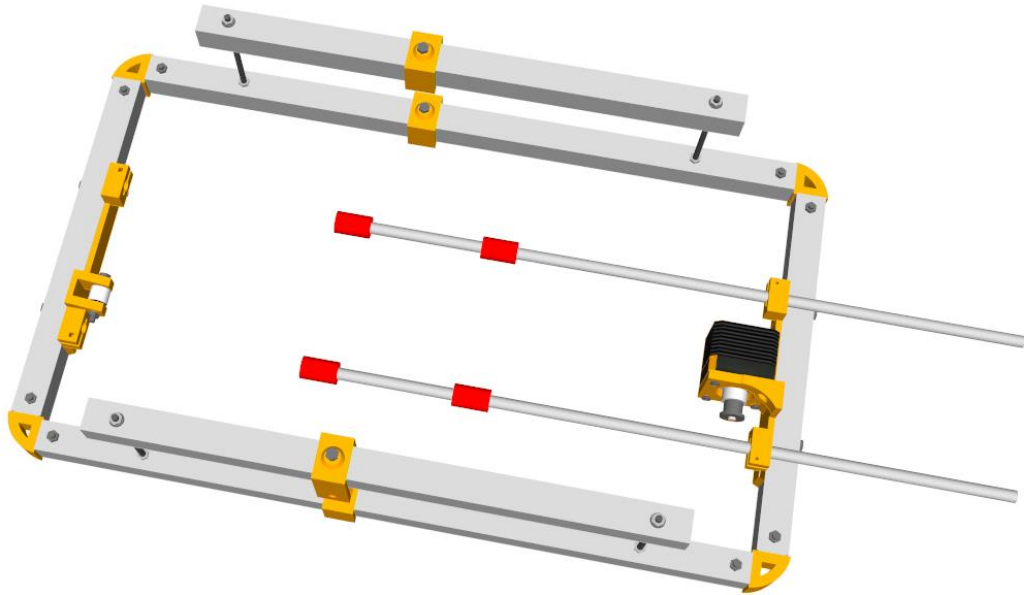

If needed use small zip ties to lock tight the smooth rods in place, normally this should not be needed.

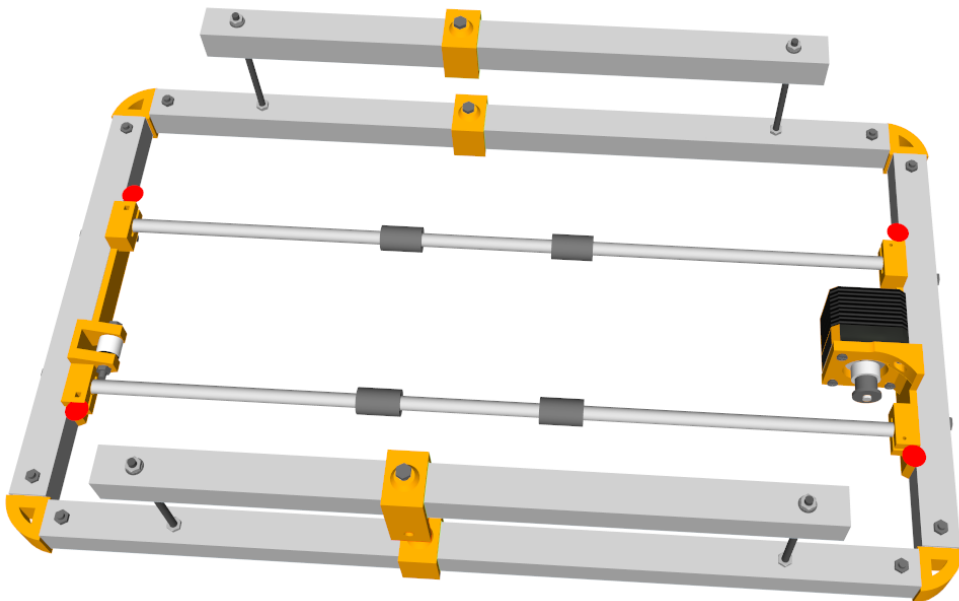

2. Take the build platform and place under the bearing secure the bearing in place using the bearing holder and two m3 x 20mm each

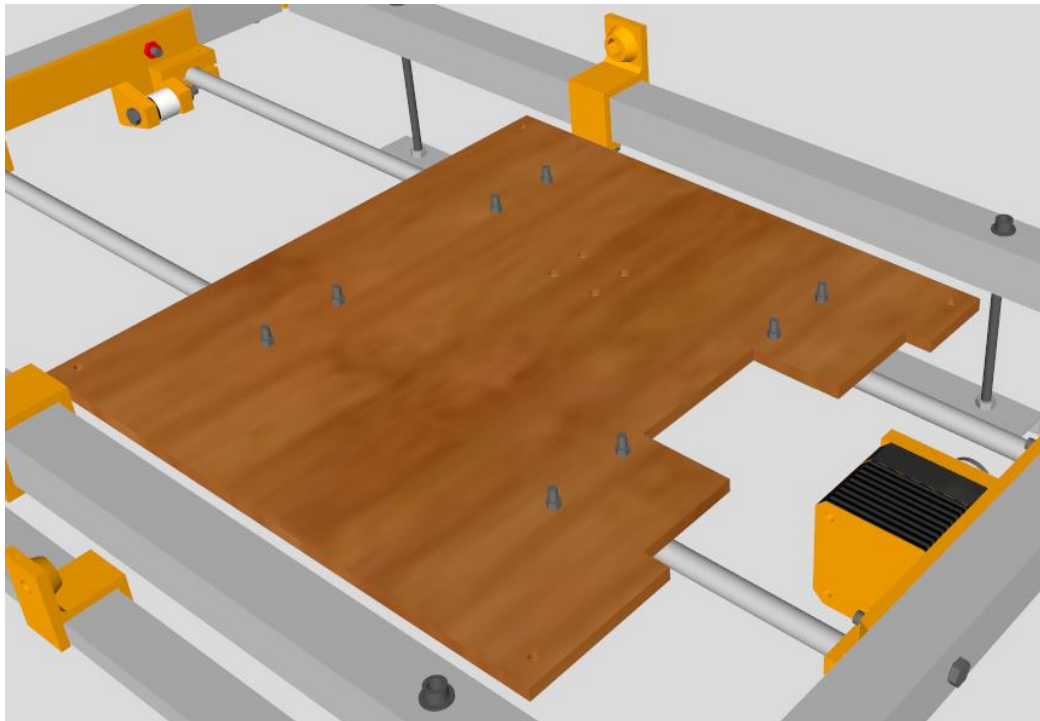
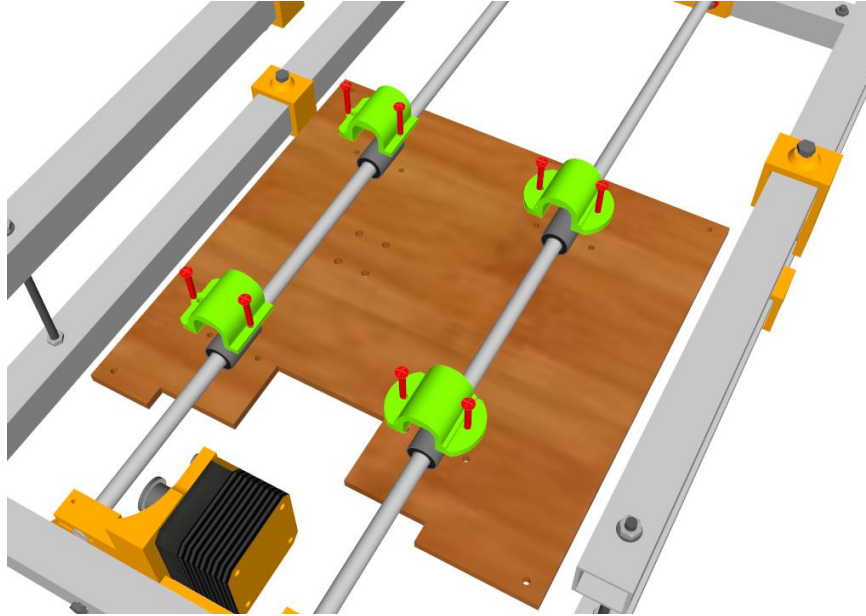

3. Belt installation. Install the belt by folding one end of the belt and using a zip tie to hold it in place across the print platform.

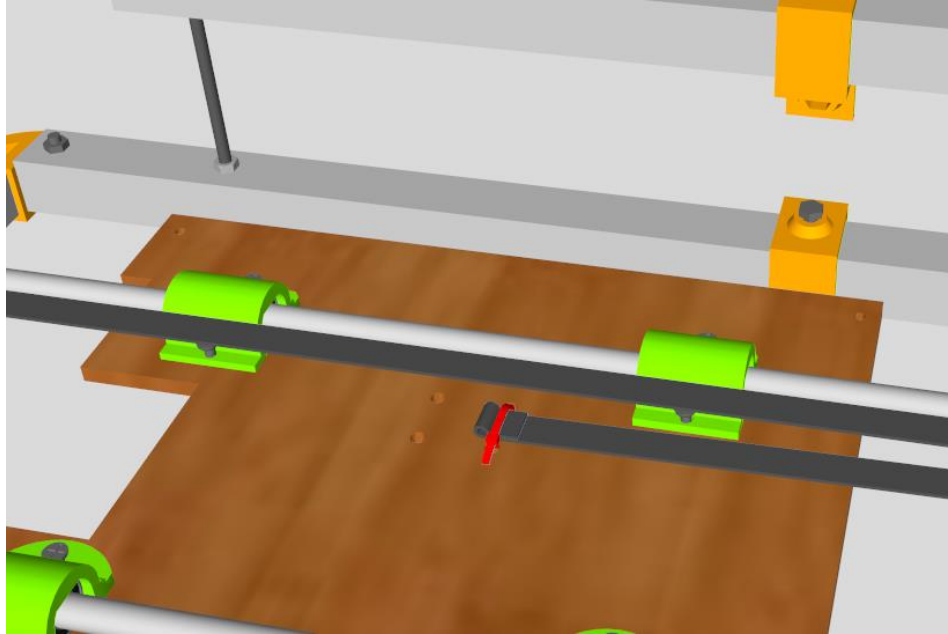

Next bring the second end close to the installed end (about 2cm spacing) using another zip tie make a notch and tie it, this time not across the build platform, only the belt

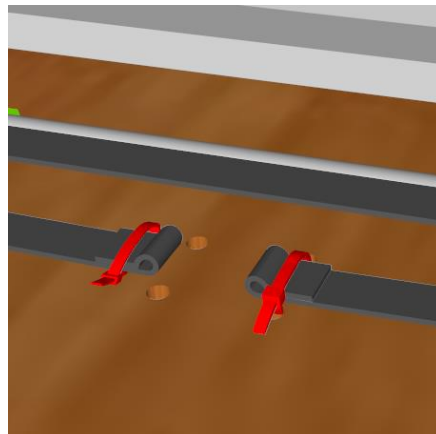

Next use a third zip tie to connect the two belt together.

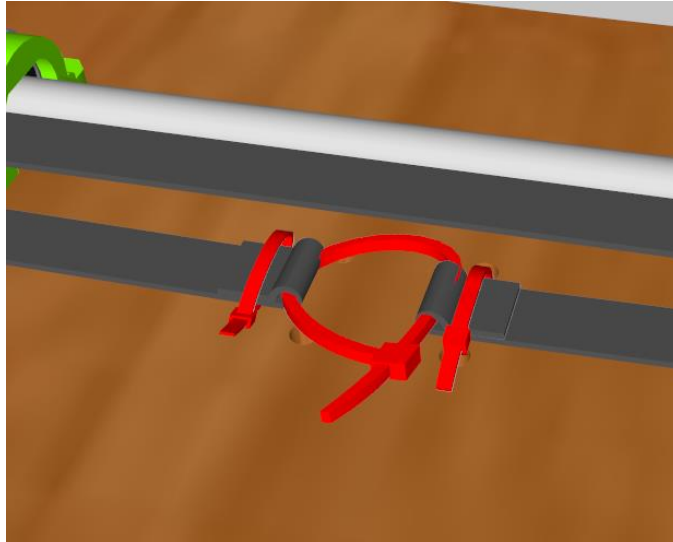

This step complete the build for the Y axis.

Assuming all goes well this is what the machine should look like now.

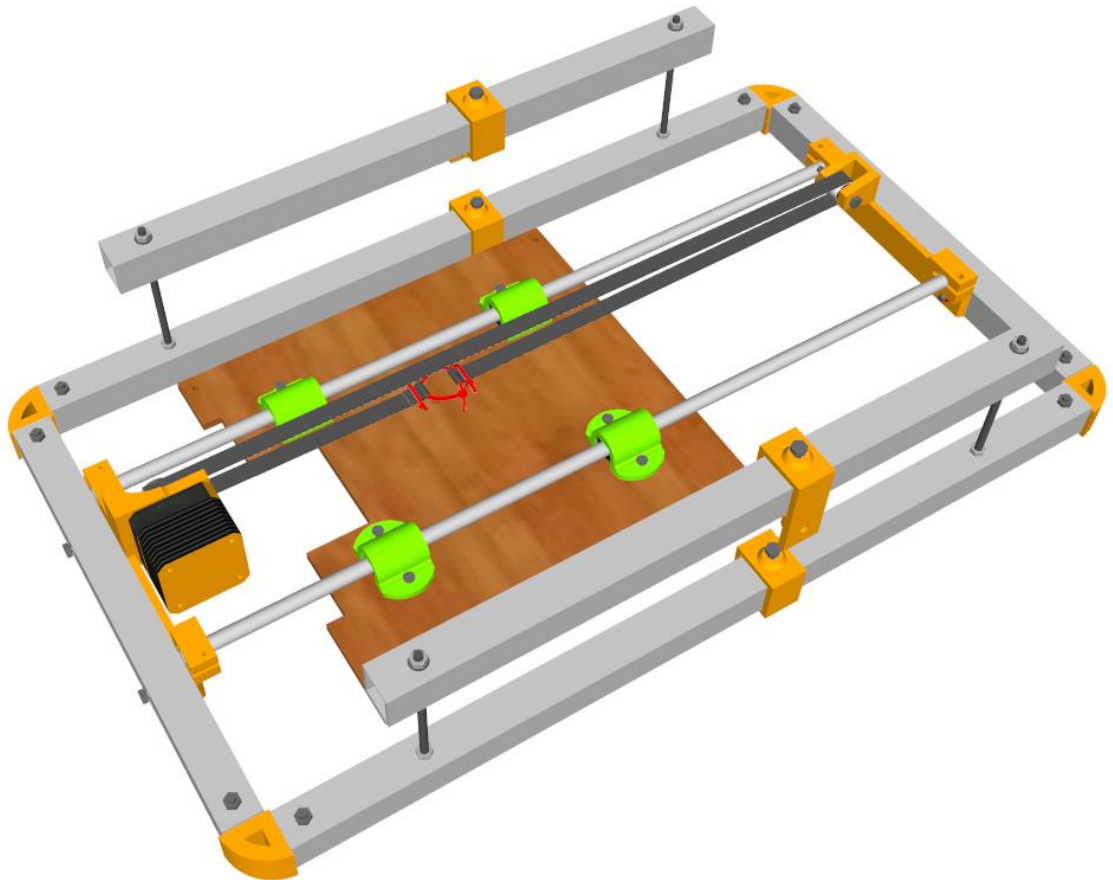

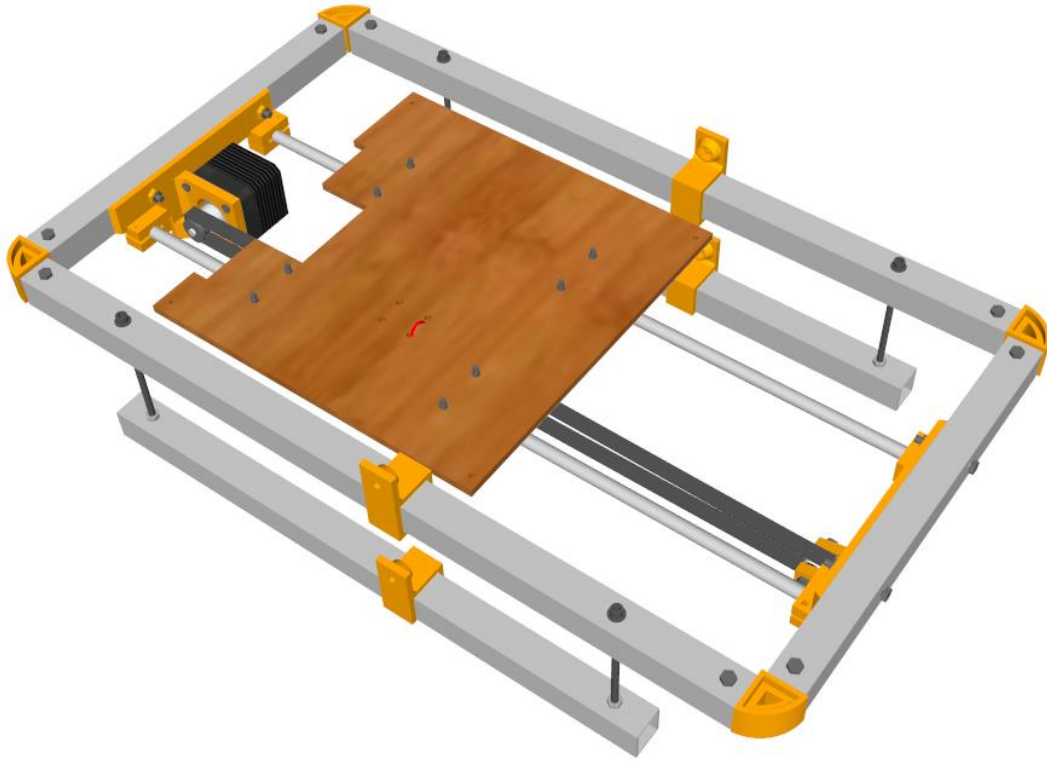

---

## THE BUILD... PART 3 (ASSEMBLING THE X AXIS)

In this part we will put together the X axis.

1. Place bearings into the X\_Ends and X\_Motor\_Ends, the bearing will go in with gentle force, sometimes it help to use a hot air pistol or air drier to warm up the plastics.

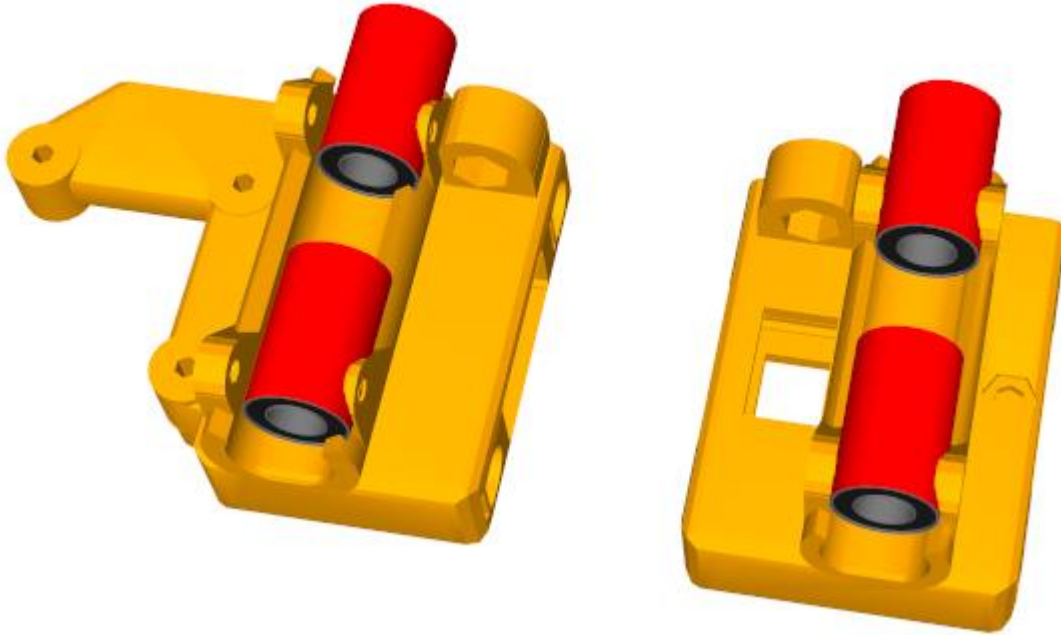

2. Install one of the stepper motors using 3 M3 X 10mm screws.



3. On the E\_End idler thread in one of the M3 x 25mm screw about half way.

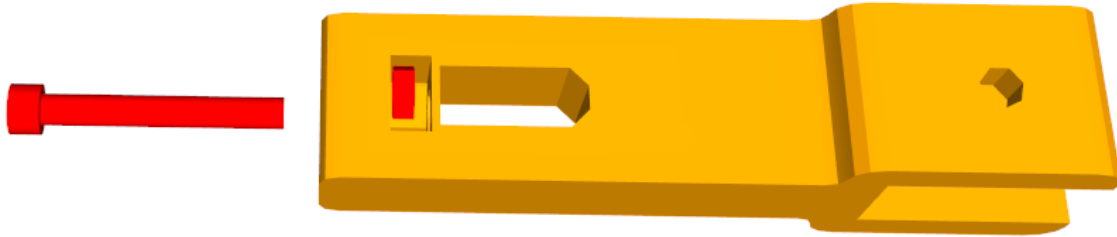

4. Insert 2 bearings with an M4 X 25mm screw and lock it in place with a washer & nut.

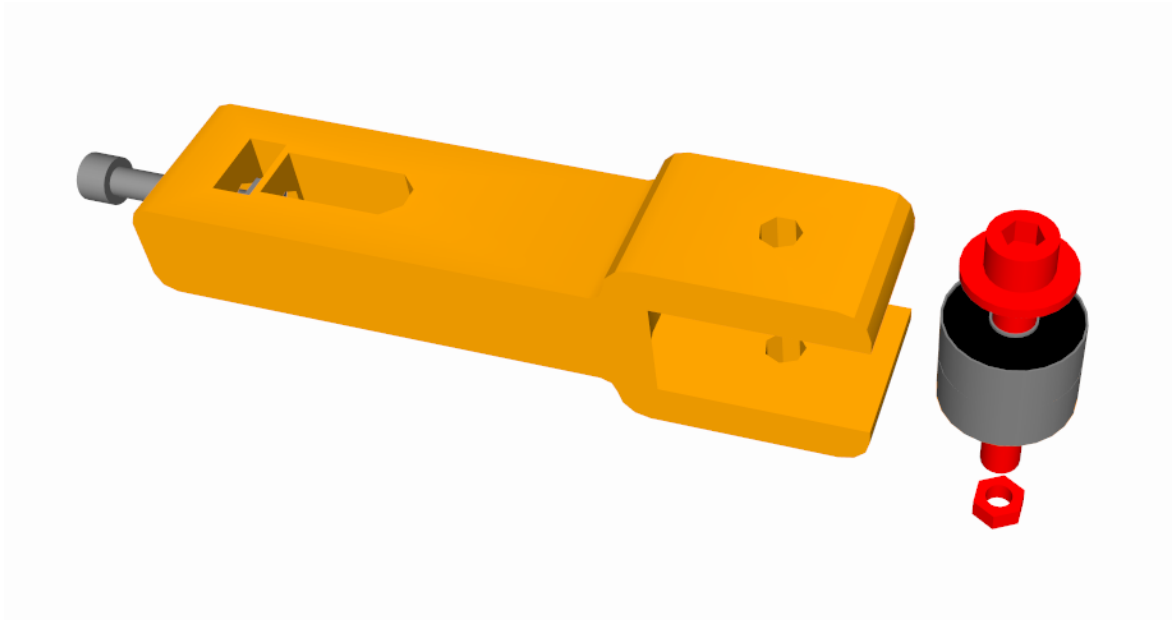

5. Put the assembly into the X\_END

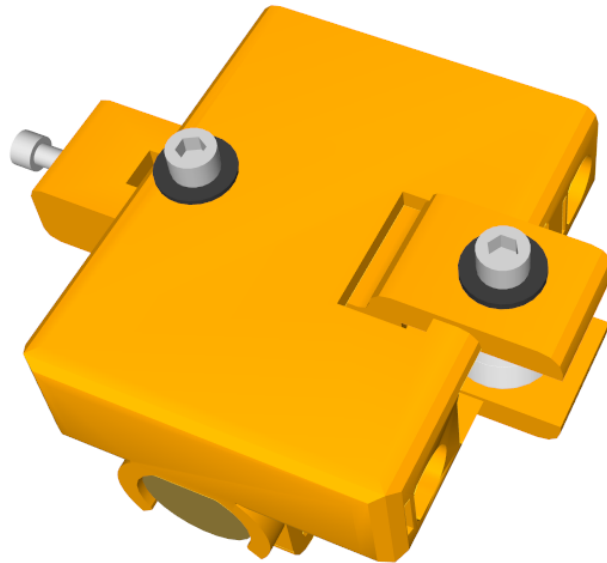

6. Insert the two X smooth rods into the X axis motor end all the way down.

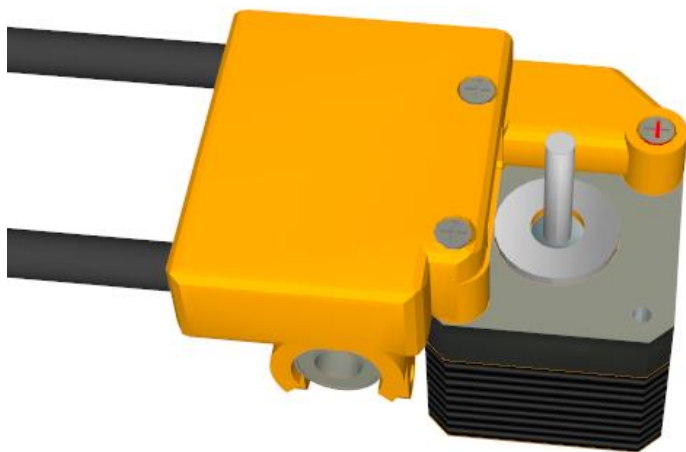



7. Insert the X axis Idler\_END into the rods, ensure that the distant between the plastics is 33Cm. Insert 4 LM8UU bearing in the rods as shown..

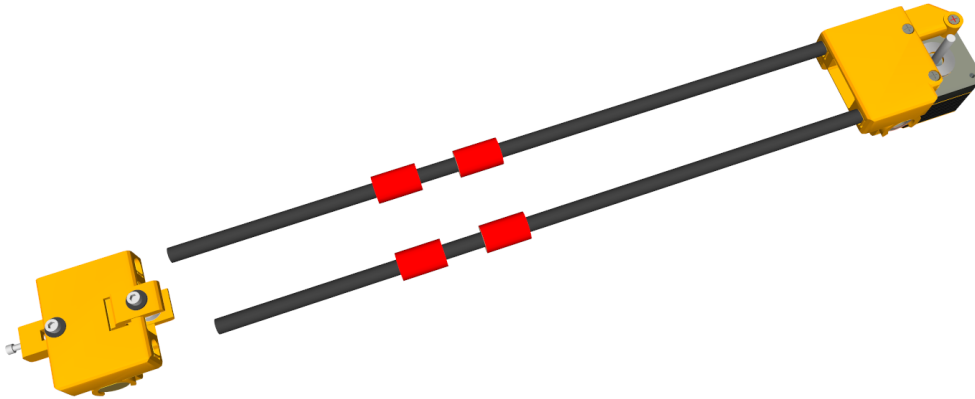

- 8.

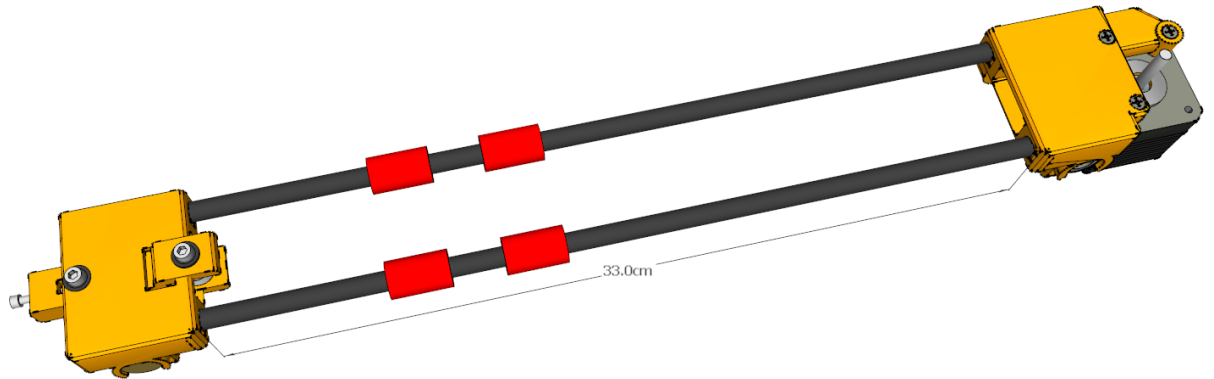

9. Place/press 5MM nuts into the X\_axis ends. If hole is tight use a soldering iron to warm up the nuts while pressing, it is important to keep the nut as flat as possible as this might affect the smooth movement of the Z axis.

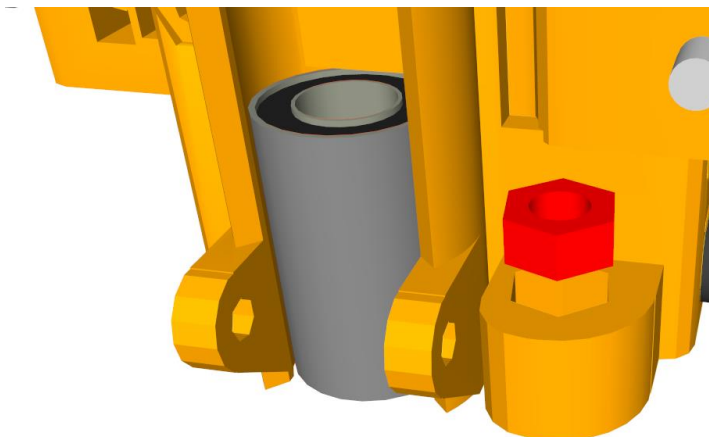

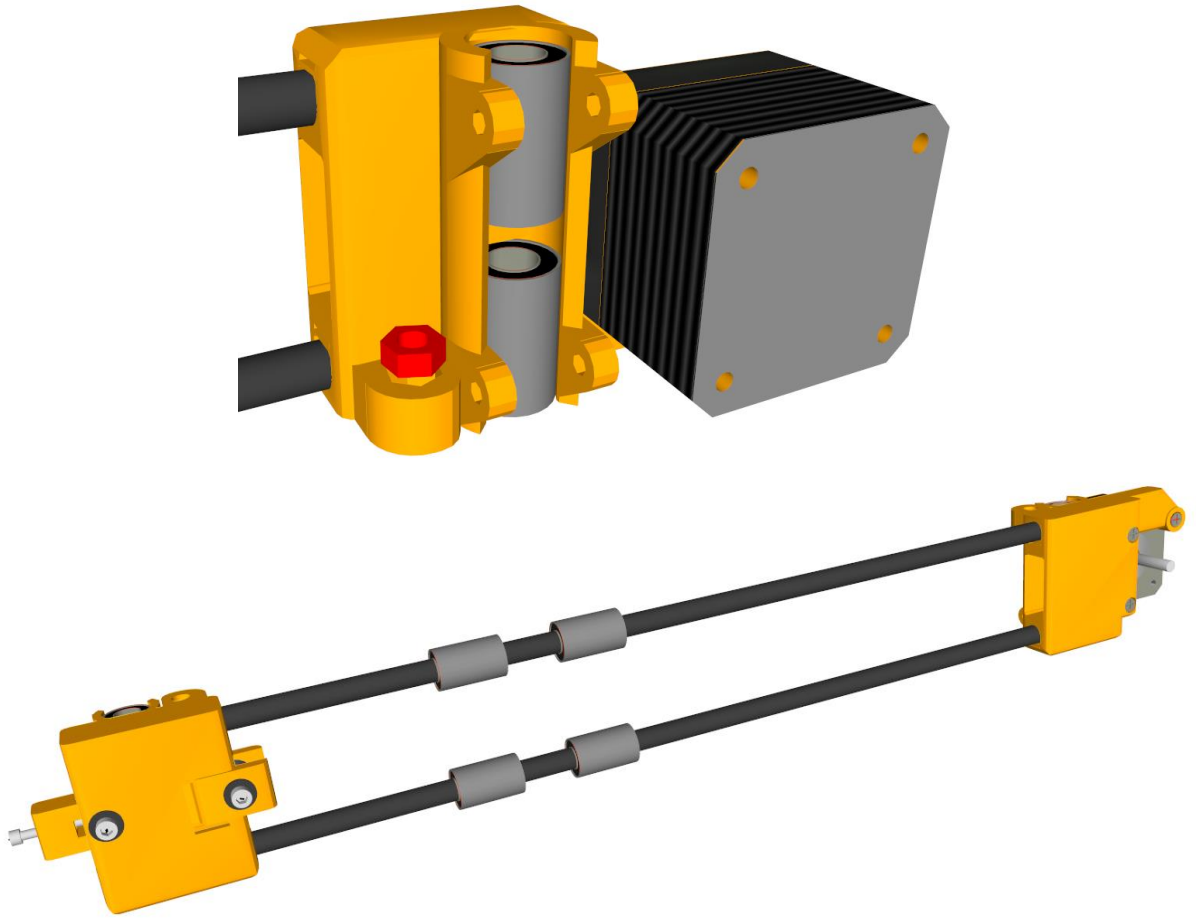

---

## THE BUILD... PART 4 (ASSEMBLING THE Z AXIS)

In this part of the build you will put together the Z axis by installing first the two side pipes and then the motors.

1. Insert the Z\_Foot\_Cap into each of the Z Pipes

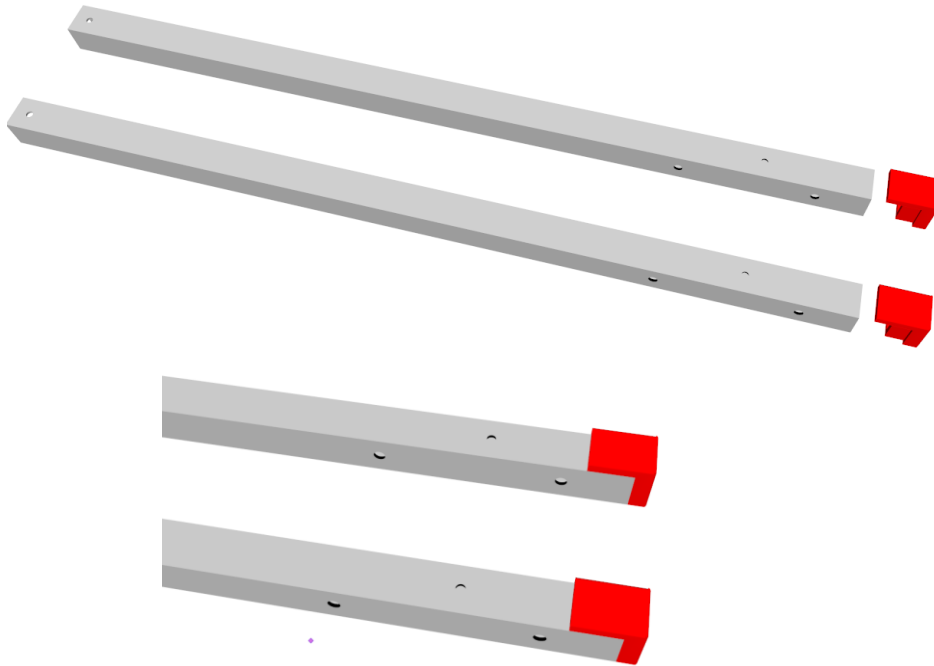

2. Mount and screw the two side pipes, take note of the hole facing

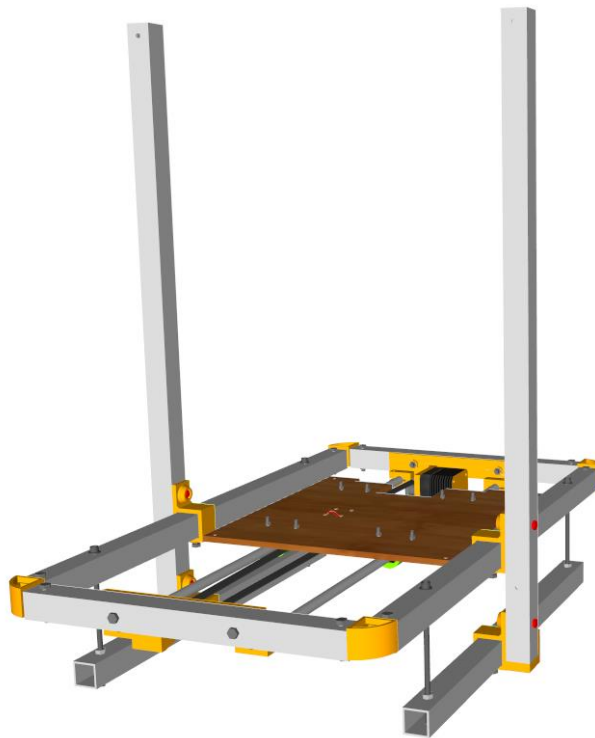
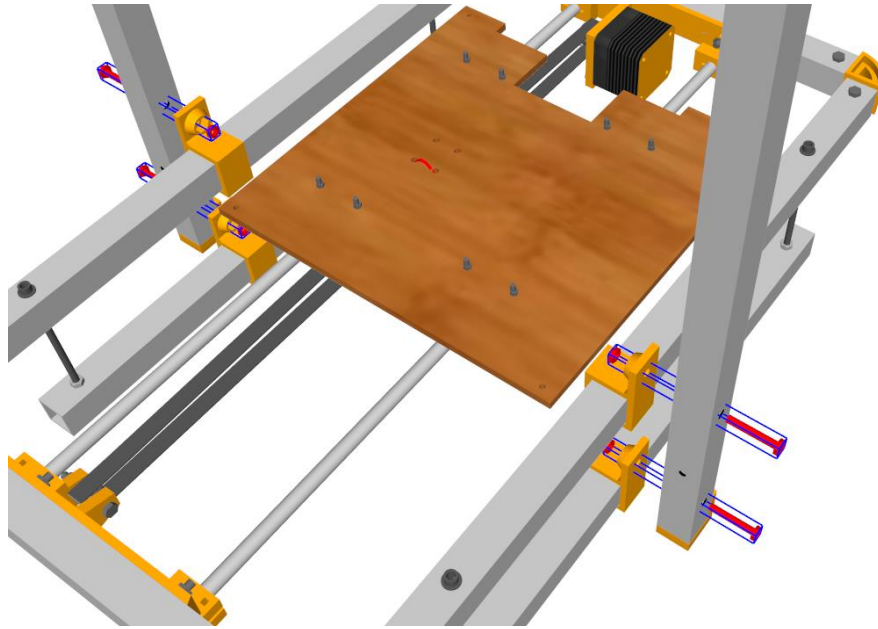

3. Insert and screw the top nine, leaving the lower holes unattached.



4. Prepare the 2 Z axis motors by using 3 M3 x 10 screws

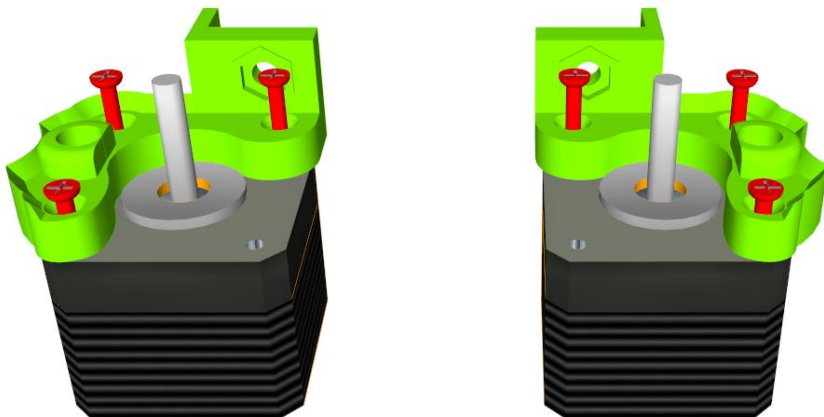

5. Insert the flexible shaft couplers half way and tighten them



6. Install the assembled motors. Not the direction it is facing!!

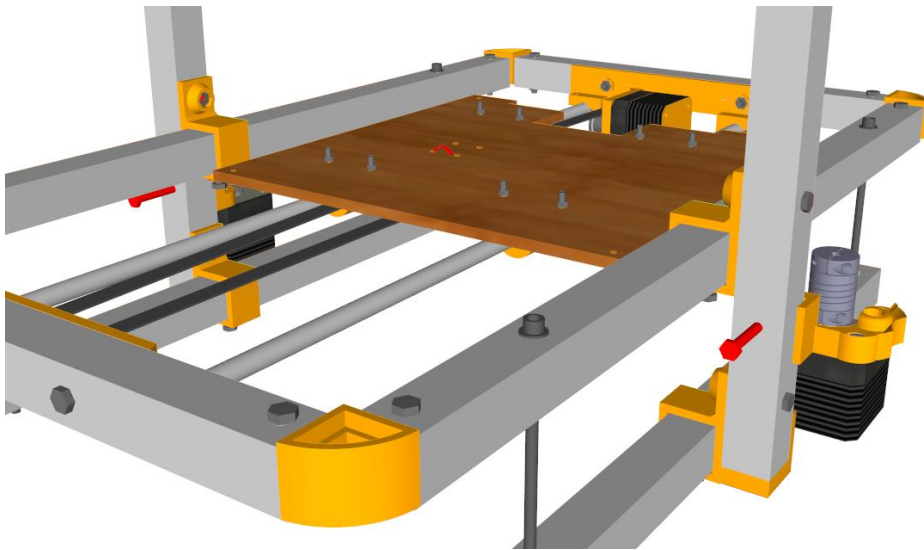

7. Insert the the 8MM smooth rods )X cm).

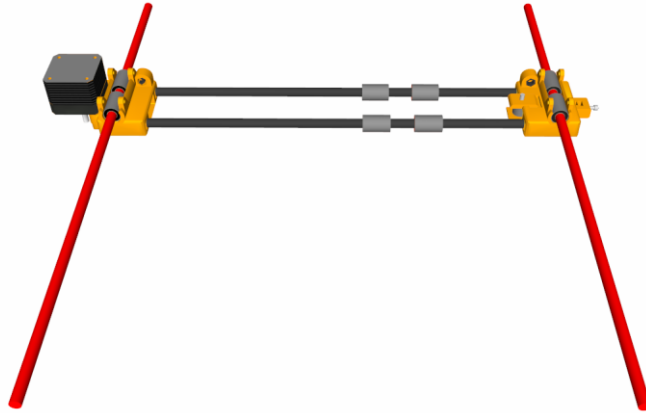

8. Carefully guide the rods into the Z axis motors. Allow the X axis to sit on the bed frame

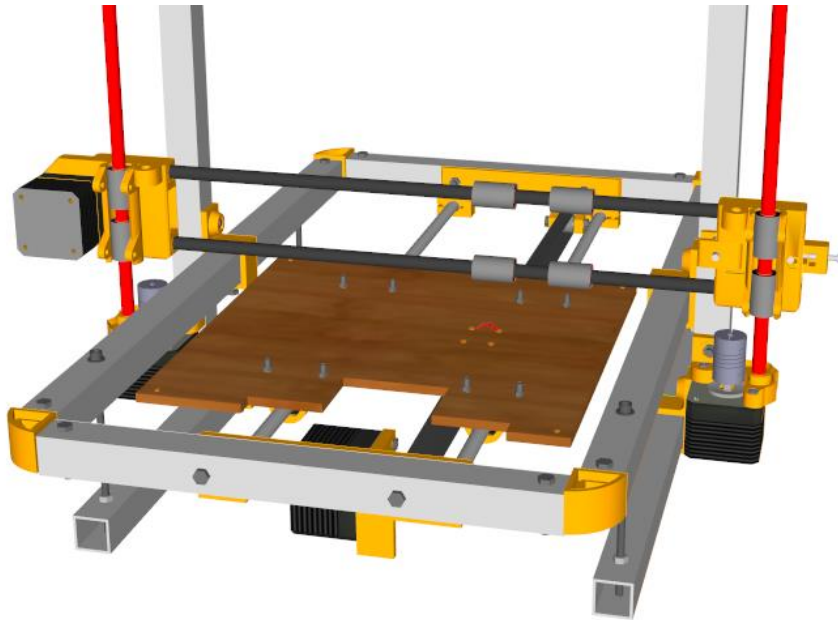

9. Tread in the 5MM threaded rod on each axis and lock it in place using the grub screw on the coupler.

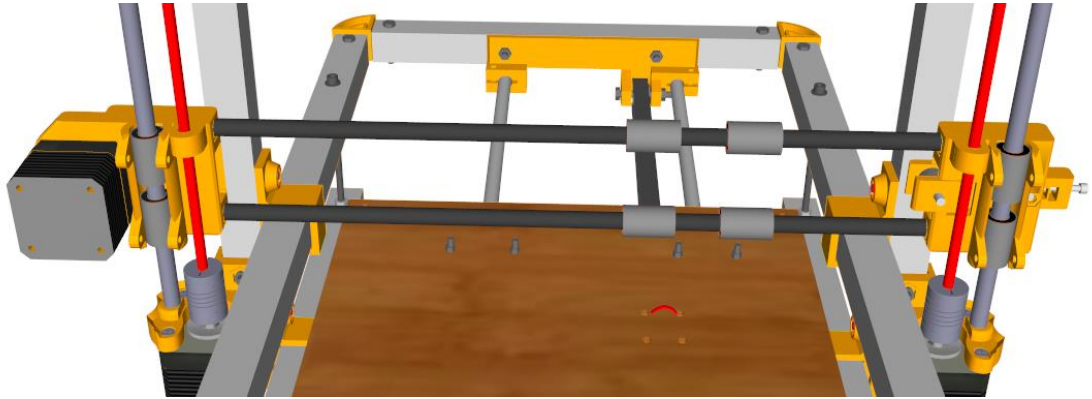

10. Place the Z\_Rod\_Holders on each side and lock in place using the 5MM x 6cm screw.

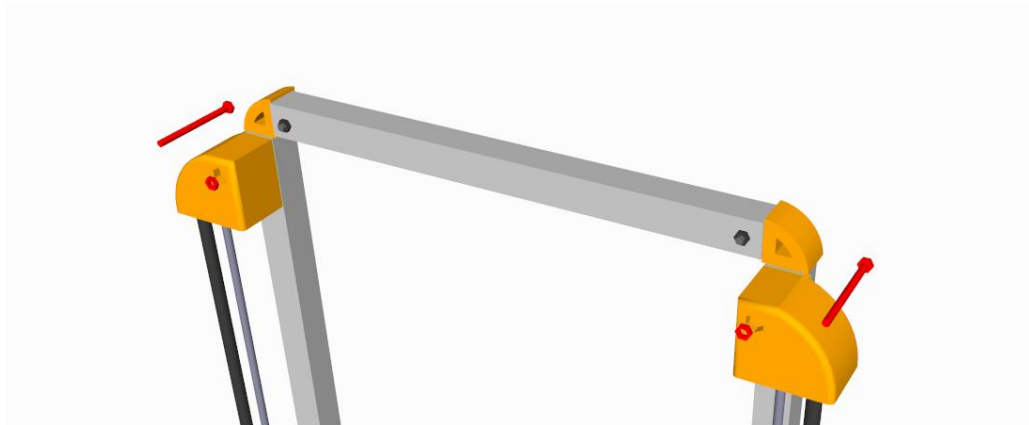



Congrats if you made it this far !!



---

## THE BUILD PART 5 (EXTRUDER CARRIAGE & BELT)

1. Place the X\_Carriage over the 4 pcs of bearing and tie in-place using zip ties

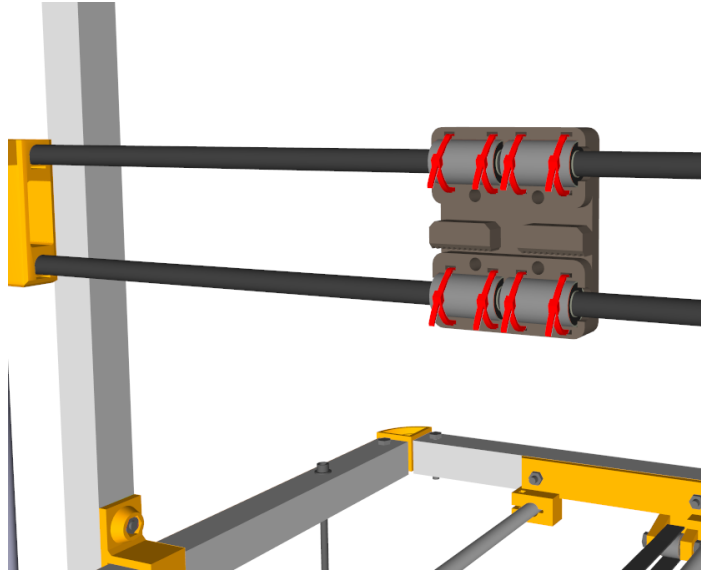

2. Insert the X axis pulley and lock it in place after centralizing it through the belt passage way.

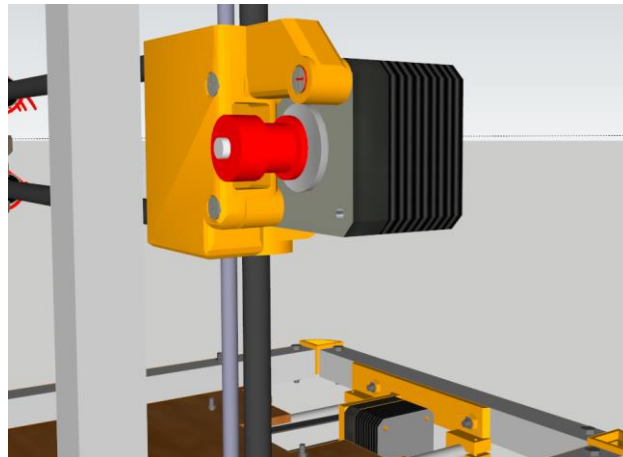

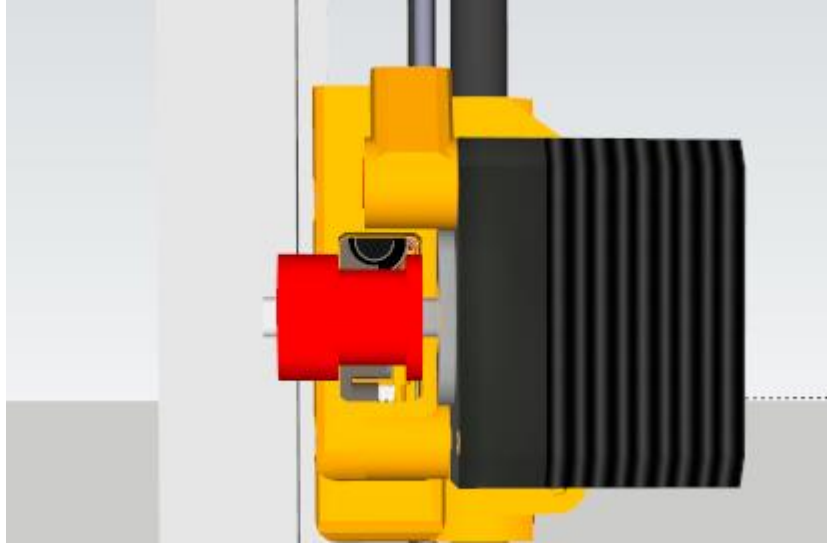

3. Pass the belt through both X ends and as tight as you can, then tension the belt using the 4MM screw on the belt tensioner

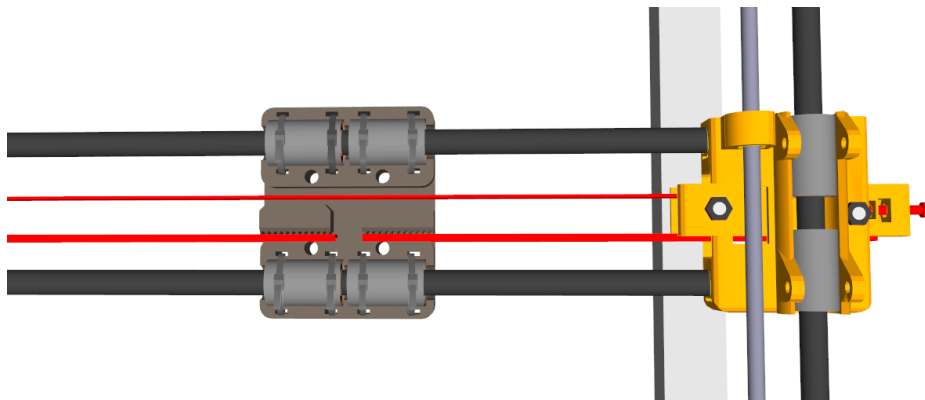

4. Assemble the Extruder sit and fan as shown below.

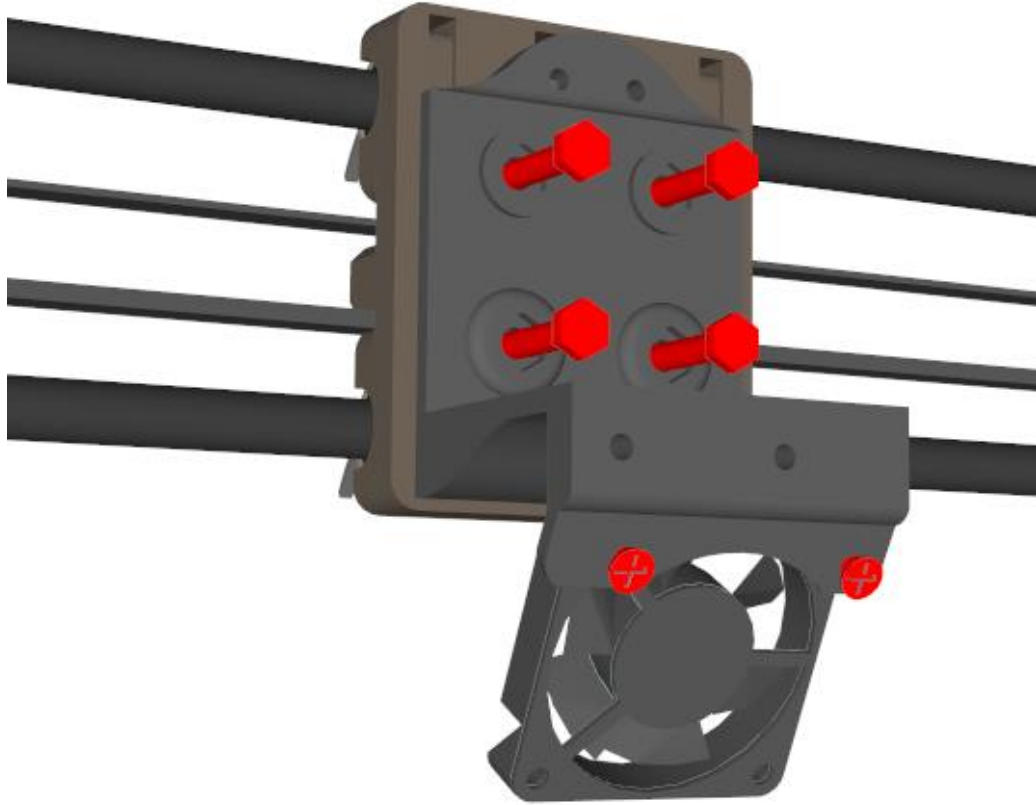

5. If you are using the TeeStruder direc drive extruder with j type hot end, assemble the extruder using the guide here [reprap wiki TeeStruder](http://reprap.org/wiki/TeeStruder) (<http://reprap.org/wiki/TeeStruder>).

6. Mount the assembled extruder on then extruder sit.

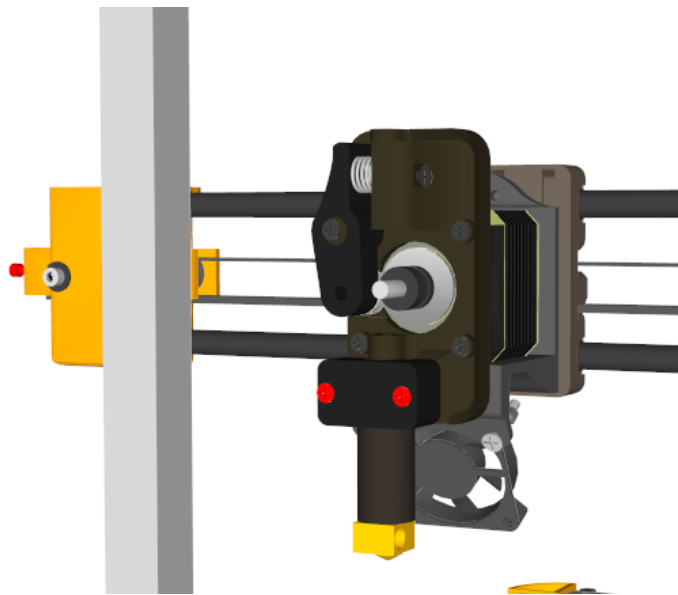

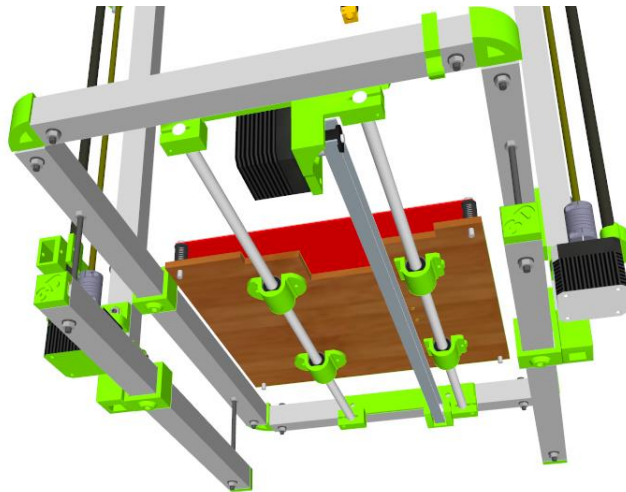
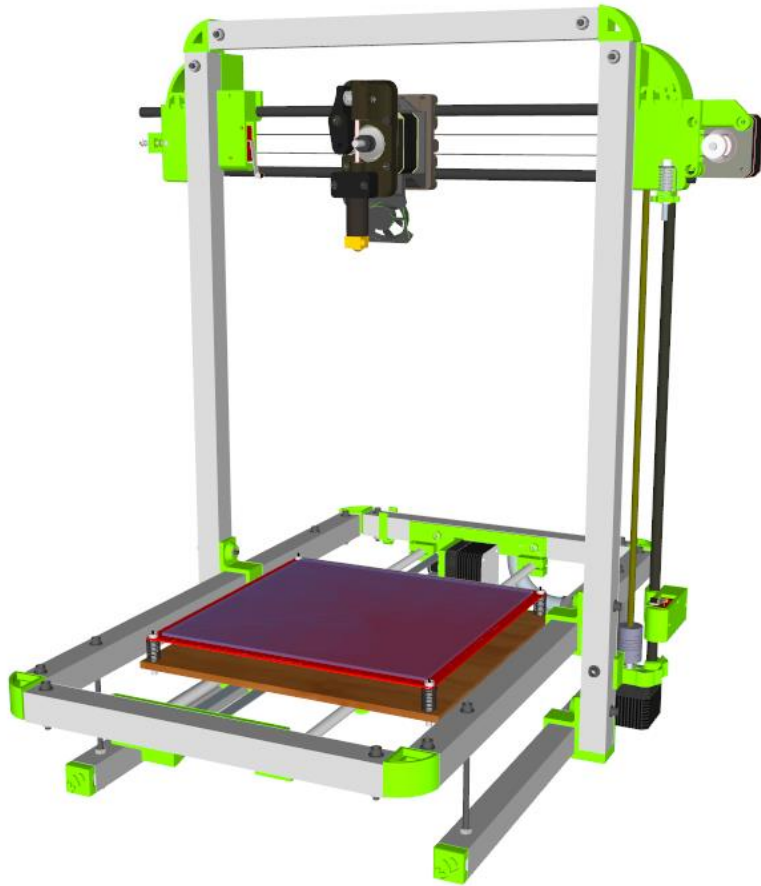

# THE BUILD PART 6 (ELECTRONICS)

How you wire/connect the electronics of the printer heavily depends on the type of control board you use.

Here is a schema overview for the most common board, RAMPS1.4

## RepRap Arduino Mega Pololu Shield 1.4

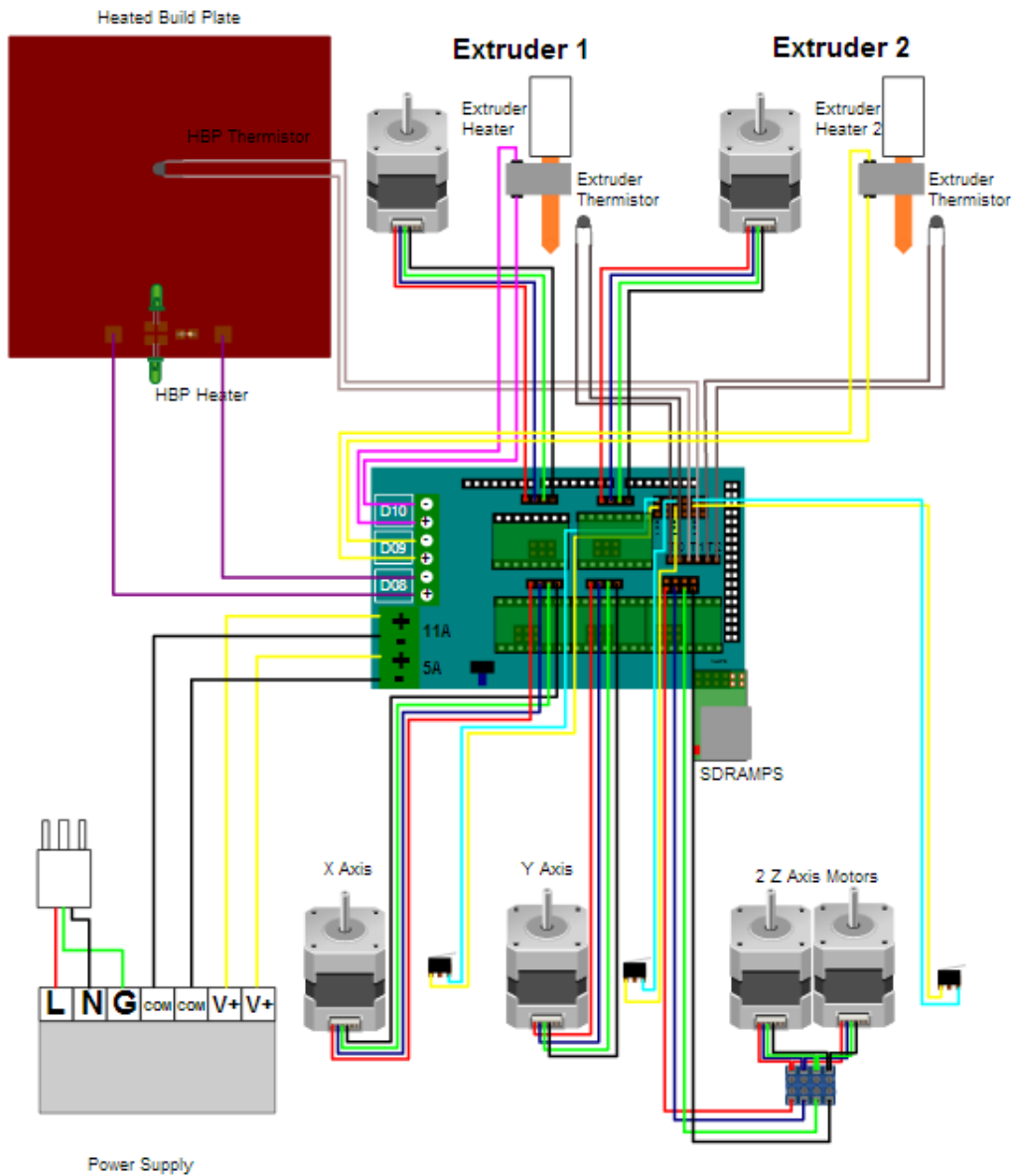

The firmware: this is the piece of code in the control board that interprets movements and instruction. If you are new to 3D printing I advise you use [Sprinter](#) and later move to use Erik Zalm [marlin](#), which basically sprinter on steroids☺.

The weblog contains a link to where you can download Marlin which is already configured for TeeBotMax. The kit supply should already have been flashed with the correct marlin firmware.

I separated the board from the printer using 37 pin Dsub connector, this allows for easy packing of the 3D printer, also you can use the same electronics board for more than one 3D printer☺.

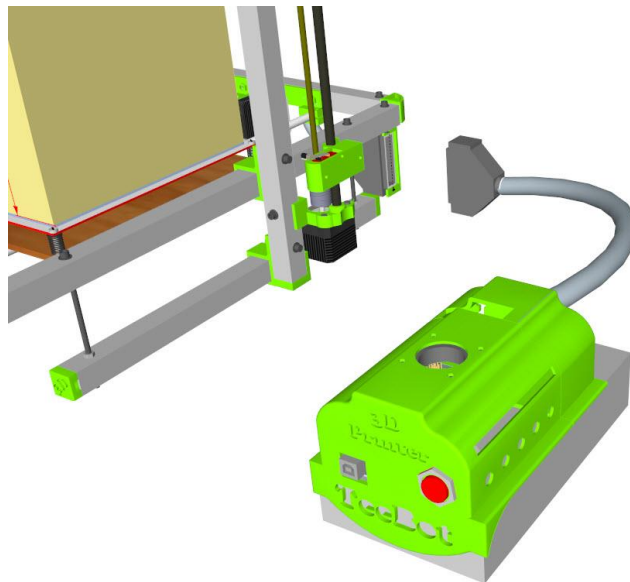

I hope this guide helps or inspire you in building or assembling your own 3D printer!! If you do please send me a photo of your build.