Getting Started Instructions for the TALP1000B

MEMS Solutions, DLP

ABSTRACT

The TALP1000B is a high performance micromirror designed for use in multiple light steering applications. The large 2-axis micromirror is constructed of single crystal silicon, which has no grain boundaries and is virtually defect free. This produces a hinge with no work hardening and gives the TALP1000B superior reliability characteristics. The gold coated optically active surface of the TALP1000B provides excellent reflectivity in the 700 nm to 10 μ m wavelength range. The mirror's large size, large radius of curvature and high reflectivity make it easy to incorporate into many optical designs.

The electromagnetic drive of the TALP1000B allows low voltage and low power actuation. The mirror can be driven using an analog drive resulting in precise pointing resolution over the entire range of motion. Each rotation axis of the device is individually and independently actuated.

Integrated position feedback on the TALP1000B is optical based and provides greater than 13 bit pointing precision. Additionally, the position feedback can be used in conjunction with a servo loop to achieve <5 millisecond mirror switch times.

The ceramic circuit board base provides a mechanically rigid design, and the three point mounting interface allows precise and repeatable assembly into system hardware. The compact size of the TALP1000B is ideal for systems with small footprint requirements.

1 Initial Bench-Top Operation

At a practical level, it is best to become familiar with this mirror and its operation by following these simple steps:

1. Fabricate or configure a fixture to mechanically capture the mirror and hold it in a bench-top test configuration. The mirror's mechanical interface is specified in the data sheet. Alternatively, a small clamp can be used to capture the mirror's package (ceramic circuit board) as long as care is taken not to clamp hard enough to damage the package.
2. Configure the bench-top test system with a visible laser incident on the center of the mirror and projected onto a screen at a known distance from the mirror. We suggest placing the incident laser beam in the horizontal plane that passes through the center of the mirror. Mark the rotation scan angle on the screen for ± 15 degrees in small increments (0.5 degrees or so). Mark off the scan angles for both the horizontal and vertical scan directions.
3. Configure a function generator and amplifier (if needed) to supply a maximum of ≈ 50 mA at 4 V_{peak}. A schematic of the TALP1000B circuit and pin function is shown below. The drive (pins 1, 2, 11 and 12) is magnetic with no ground but a voltage difference applied between the matched drive pins (1 and 2, 11 and 12) produces a current which rotates the mirror. When positive voltage is applied to pin 1 (lower voltage returned from pin 2), a beam reflected off of the mirror rotates in the westerly direction. When positive voltage is applied to pin 12 (lower voltage returned from pin 11), a beam reflected off of the mirror rotates in the northerly direction. North and west arrows are on both sides of the package (see the interface drawing on the data sheet).

Table 1.

| TERMINAL | |
|----------|---------------------|
| NO. | NAME |
| 1 | West |
| 2 | East |
| 3 | Det/LED/TSensor Vdd |
| 4 | Det/Temp Sensor Grd |
| 5 | NW Output |
| 6 | SW Output |
| 7 | SE Output |
| 8 | NE Output |
| 9 | Temp Sensor Read |
| 10 | LED Drive |
| 11 | South |
| 12 | North |

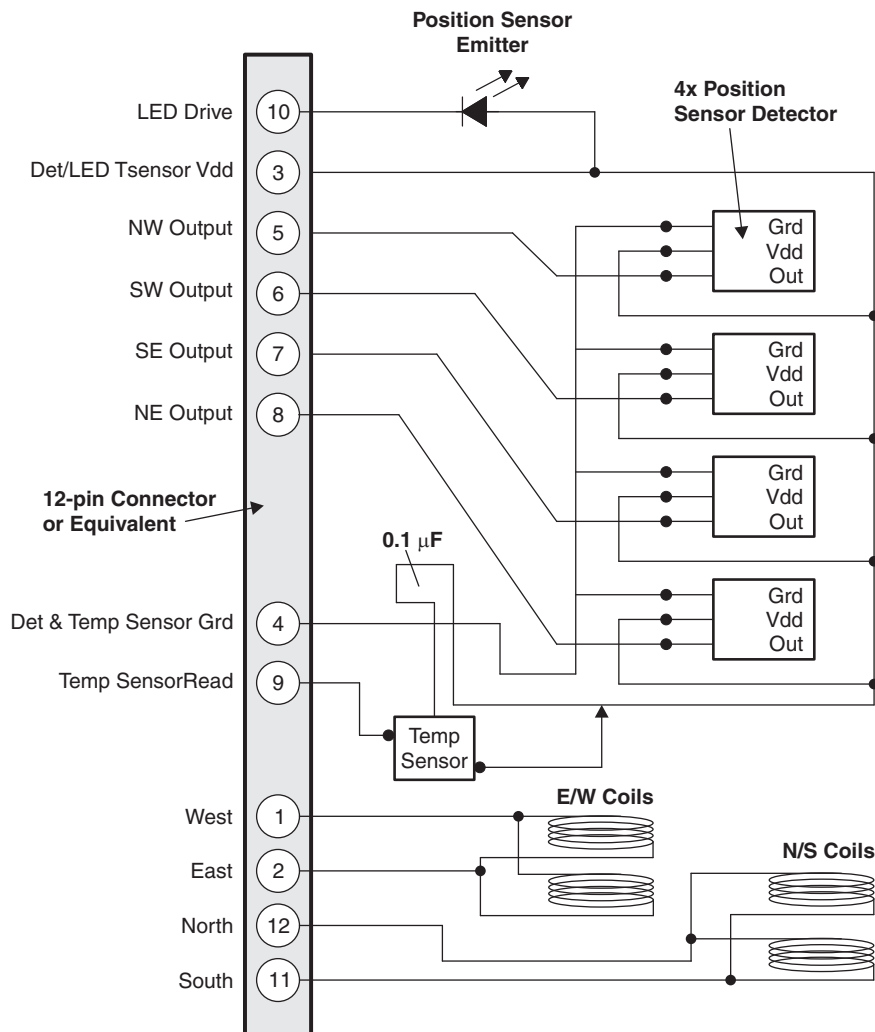
4. Scanning operation:

- a. Set the function generator drive frequency to 5 Hz. Apply a 0.5 Vrms sine wave across pins 1 and 2 by starting at zero volts and gradually increasing the voltage until 0.5 Vrms is reached.

- b. Slowly increase the drive voltage while watching the scanned beam on the screen until the scanned beam reaches ± 10 degrees optical (remember that the mirror's mechanical rotation is of the optical scan angle and ± 10 degrees optical corresponds to ± 5 degrees mechanical rotation of the mirror).
- c. Vary the scanning frequency up and down and become familiar with the mirrors function. As the drive frequency approaches the mirror resonance frequency for a particular axis, the efficiency of the drive dramatically increases and the drive voltage must be dramatically lowered so the mirror is not driven into the rotation stops. Operation is possible near, at, or above resonance but care must be taken not to overdrive the mirror.

WARNING

Care must be taken when driving the mirror to guarantee that the mirror's rotational amplitude does not exceed ± 5 degrees mechanical (± 10 degrees optical).

- d. Set the function generator/amplifier to drive across pins 11 and 12 and repeat steps a-c above and become familiar with the mirror operation in this axis.
 - e. Optional: Configure a dual independent drive for both axes and become familiar with the mirror operation while scanning both axes.
5. Be careful to avoid start stop transients when starting or stopping the sinusoidal drive voltage. If one sets the 50Hz drive power to a voltage that produces a large 50 Hz mirror rotation (4 to 5 degrees mechanical motion) then the mirror will operate for many thousands of hours without problem. However, if one powers the sine drive power supply down or up at a time when the voltage output is significant, then a voltage step occurs that will excite the mirror's resonance and can result in quite large rotation angles (enough to cause the mirror to hit the ceramic circuit board which serves as a rotation stop). There are two ways to avoid this: a) power up or down only when the drive voltage is near zero (shown in the drawing below), b) reduce the amplitude of the sine drive before powering up or down.

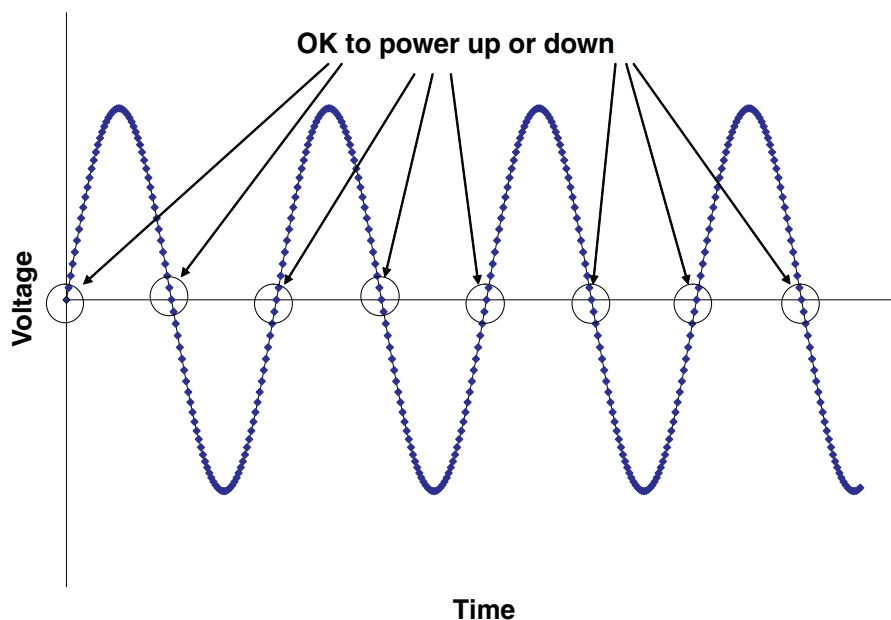

6. Pointing Operation
 - a. Configure the drive so that a DC voltage/current can be applied. Apply 0.2 V DC across the pins 1 and 2 as a step from 0 V.

-
- Note:** 1) The mirror moves and then rings down to a steady state position over several seconds.
 2) The step in voltage excites motion at resonance and there is overshoot produced by the step in voltage.
-

- b. Slowly Increase the DC drive voltage while watching the beam position until 5 degrees scan angle is reached (2.5 degrees mechanical angle). Now turn off the DC voltage and then turn it back on. Note the overshoot to approximately 10 degrees optical (remember that the mirror's mechanical rotation is half of the optical scan angle and ± 10 degrees optical corresponds to ± 5 degrees mechanical rotation of the mirror). A control loop using the mirror's internal position feedback (IPF) can be used to avoid the overshoot and ringing.

WARNING

Care must be taken to insure that the mirror's rotational amplitude (including the overshoot from ringing does not exceed +/-5 degrees mechanical (± 10 degrees optical)).

- c. Set the voltage source to drive across pins 11 and 12 and repeat steps a) and b) above and become familiar with the mirror operation in this axis.
 d. Optional: Configure a dual independent drive for both axes and become familiar with the mirror operation while pointing using both axes.

[Figure 1](#) and [Figure 2](#) show the north-south and east-west rotation versus drive voltage curves for a typical TALP1000B mirror.

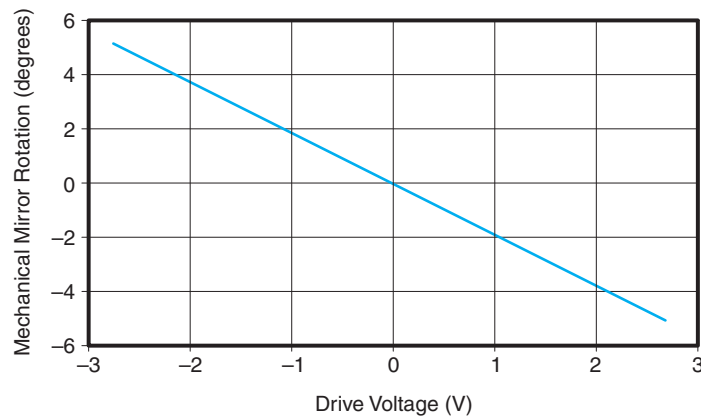

Figure 1. North-South Drive

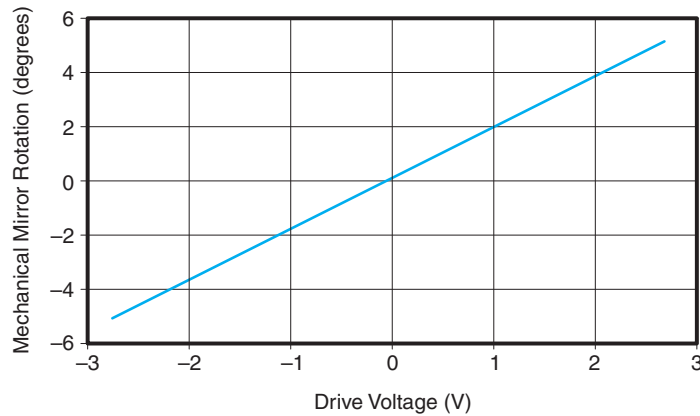
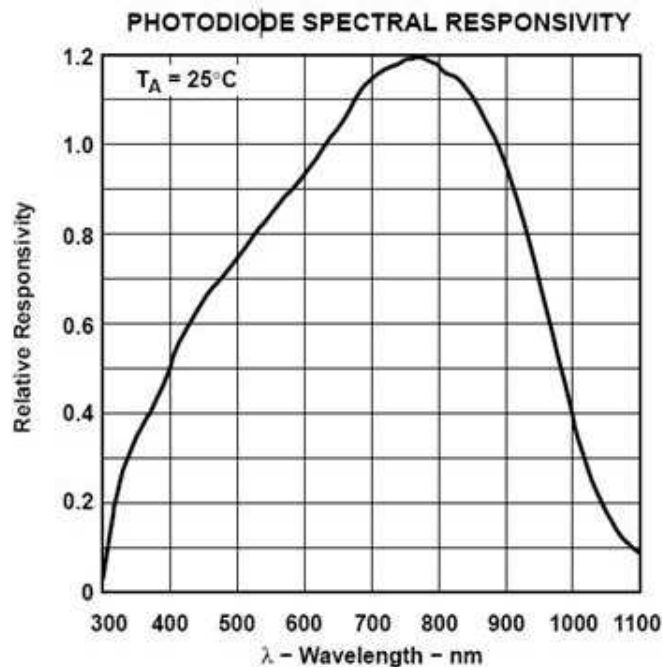

Figure 2. East-West Drive

2 Internal Position Feedback (IPF)

The position sensor outputs of the TALP1000B are generated by an LED and four photodiodes (light to voltage detectors) arranged below the mirror. As the mirror rotates the light intensity at each detector varies and this variation is used to determine the position of the mirror. Note the photodiode spectral responsivity for the four Si detectors shown below. Any light from the signal (laser) beam which spills over onto the open gaps around the mirror or ambient light which is between 300 and 1200 nm can interfere with the operation of the IPF. The feedback is still functional with external illumination that interferes with the IPF but at lower performance than specified and with the following caveats: 1) care must be taken not to saturate the detectors, 2) any variation in the external illumination (from windows or other sources) will cause drift in the IPF signal 3) SNR will be lower than specified. We recommend placing the bench top test equipment in a darkened room and switching off the visible laser when measuring IPF signals (a 1.5 micron laser need not be turned off as it will not produce a signal in the Si detectors).



To determine the mirror's position using the IPF one can construct a mirror position versus feedback signal as follows:

1. Power (+5 V) and ground must be supplied to pins 3 and 4 for the IPF to function.

2. The LED drive pin (10) must be held at a voltage sufficiently below 5 V so that the LED pulls ≈ 12 mA of current.
3. With the mirror in its quiescent (zero current flowing in the drive coils) position, measure the output of the NE, SE, NW, and SW detectors. The position sensor parameter for the east-west direction is then $IPF_x = (NE + SE - NW - SW) / (NE + SE + NW + SW)$ and the position sensor parameter for the north-south direction is then $IPF_y = (NE - SE + NW - SW) / (NE + SE + NW + SW)$ where NE, SE, NW and SW denote the voltage outputs of the north east, south east, north west and south west detectors (pins 8, 7, 5, and 6 respectively).
4. Move the mirror to another position in the East-West direction by applying a current through the East-West coils. Record the mirror angle detector values and calculate the IPF parameters as in step 3 above. In the table below data was taken after every 2mA step in East-West drive current. Make sure that sufficient time elapses after mirror motion to allow the mirror to stop moving and then take the measurements.
5. Repeat step 4 while driving the North South coils at increments of 2 mA.
6. Construct a table of detector outputs, IPF parameters and mirror position similar to the tables below. The inner reflective surface or "Mirror" is suspended by hinges and moves independently in the East-West direction. The gimbals and inner reflective surface are suspended by hinges and move together in the North-South direction. In the following table the East-West deflection is called "Mirror" deflection and the North-South deflection is called "Gimbals" deflection.

Table 2. Mirror Deflection with Gimbal Coil Current = 0 mA

| EAST-WEST CURRENT (mA) | EAST-WEST VOLTAGE (V) | NORTH-SOUTH CURRENT (mA) | NW DETECTOR OUT (V) | NE DETECTOR OUT (V) | SE DETECTOR OUT (V) | SW DETECTOR OUT (V) | IPFx WITH EAST-WEST MOTION | IPFy WITH EAST-WEST MOTION | EAST-WEST ANGLE (deg) | NORTH-SOUTH ANGLE (deg) |
|------------------------|-----------------------|--------------------------|---------------------|---------------------|---------------------|---------------------|----------------------------|----------------------------|-----------------------|-------------------------|
| 0 | 0 | 0 | 1.441 | 1.649 | 1.722 | 1.585 | -0.054 | 0.034 | 0.05 | 0.02 |
| 2 | 0.132 | 0 | 1.458 | 1.634 | 1.711 | 1.602 | -0.044 | 0.034 | -0.21 | 0.02 |
| 4 | 0.264 | 0 | 1.475 | 1.617 | 1.698 | 1.618 | -0.035 | 0.035 | -0.46 | 0.02 |
| 6 | 0.396 | 0 | 1.491 | 1.6 | 1.684 | 1.634 | -0.025 | 0.035 | -0.71 | 0.01 |
| 8 | 0.528 | 0 | 1.507 | 1.583 | 1.669 | 1.65 | -0.015 | 0.036 | -0.94 | 0.01 |
| 10 | 0.66 | 0 | 1.522 | 1.565 | 1.653 | 1.664 | -0.005 | 0.036 | -1.19 | 0.01 |
| 12 | 0.792 | 0 | 1.537 | 1.547 | 1.636 | 1.679 | 0.005 | 0.036 | -1.45 | 0 |
| 14 | 0.924 | 0 | 1.552 | 1.528 | 1.619 | 1.693 | 0.015 | 0.036 | -1.7 | 0 |
| 16 | 1.056 | 0 | 1.566 | 1.508 | 1.602 | 1.706 | 0.025 | 0.037 | -1.95 | 0 |
| 18 | 1.188 | 0 | 1.58 | 1.488 | 1.586 | 1.719 | 0.035 | 0.037 | -2.2 | -0.01 |
| 20 | 1.32 | 0 | 1.594 | 1.468 | 1.569 | 1.732 | 0.046 | 0.038 | -2.45 | -0.01 |
| 22 | 1.452 | 0 | 1.607 | 1.446 | 1.552 | 1.745 | 0.056 | 0.038 | -2.71 | -0.02 |
| 24 | 1.584 | 0 | 1.621 | 1.424 | 1.536 | 1.758 | 0.066 | 0.039 | -2.97 | -0.02 |
| 26 | 1.716 | 0 | 1.634 | 1.402 | 1.519 | 1.77 | 0.076 | 0.04 | -3.22 | -0.03 |
| 28 | 1.848 | 0 | 1.648 | 1.379 | 1.502 | 1.783 | 0.087 | 0.041 | -3.48 | -0.03 |
| 30 | 1.98 | 0 | 1.662 | 1.356 | 1.484 | 1.795 | 0.098 | 0.042 | -3.75 | -0.04 |
| 32 | 2.112 | 0 | 1.675 | 1.333 | 1.467 | 1.807 | 0.109 | 0.042 | -4.01 | -0.04 |
| 34 | 2.244 | 0 | 1.687 | 1.31 | 1.448 | 1.818 | 0.119 | 0.043 | -4.28 | -0.05 |
| 36 | 2.376 | 0 | 1.699 | 1.287 | 1.429 | 1.829 | 0.13 | 0.044 | -4.56 | 0.06 |
| 38 | 2.508 | 0 | 1.711 | 1.264 | 1.41 | 1.839 | 0.141 | 0.044 | -4.84 | -0.07 |
| 40 | 2.64 | 0 | 1.721 | 1.241 | 1.389 | 1.849 | 0.152 | 0.044 | -5.12 | -0.07 |
| -2 | -0.132 | 0 | 1.429 | 1.669 | 1.74 | 1.573 | -0.063 | 0.034 | 0.27 | 0.02 |
| -4 | -0.264 | 0 | 1.414 | 1.687 | 1.756 | 1.56 | -0.073 | 0.033 | 0.52 | 0.02 |
| -6 | -0.396 | 0 | 1.4 | 1.705 | 1.771 | 1.545 | -0.083 | 0.033 | 0.77 | 0.04 |
| -8 | -0.528 | 0 | 1.384 | 1.722 | 1.786 | 1.53 | -0.092 | 0.033 | 1.02 | 0.03 |
| -10 | -0.66 | 0 | 1.369 | 1.738 | 1.8 | 1.515 | -0.102 | 0.032 | 1.26 | 0.04 |
| -12 | -0.792 | 0 | 1.353 | 1.754 | 1.814 | 1.5 | -0.111 | 0.032 | 1.46 | 0.03 |
| -14 | -0.924 | 0 | 1.336 | 1.769 | 1.828 | 1.483 | -0.121 | 0.032 | 1.69 | 0.03 |
| -16 | -1.056 | 0 | 1.319 | 1.785 | 1.841 | 1.466 | -0.131 | 0.032 | 1.92 | 0.02 |
| -18 | -1.188 | 0 | 1.302 | 1.8 | 1.854 | 1.45 | -0.141 | 0.032 | 2.15 | 0.03 |
| -20 | -1.32 | 0 | 1.285 | 1.814 | 1.867 | 1.434 | -0.15 | 0.032 | 2.45 | 0.03 |
| -22 | -1.452 | 0 | 1.268 | 1.829 | 1.88 | 1.418 | -0.16 | 0.031 | 2.71 | 0.03 |
| -24 | -1.584 | 0 | 1.251 | 1.844 | 1.893 | 1.403 | -0.169 | 0.032 | 2.96 | 0.03 |
| -26 | -1.716 | 0 | 1.234 | 1.858 | 1.906 | 1.388 | -0.179 | 0.032 | 3.22 | 0.02 |
| -28 | -1.848 | 0 | 1.217 | 1.872 | 1.919 | 1.373 | -0.188 | 0.032 | 3.48 | 0.02 |
| -30 | -1.98 | 0 | 1.199 | 1.887 | 1.932 | 1.357 | -0.198 | 0.032 | 3.73 | 0.02 |
| -32 | -2.112 | 0 | 1.182 | 1.901 | 1.945 | 1.341 | -0.208 | 0.032 | 3.99 | 0.02 |
| -34 | -2.244 | 0 | 1.165 | 1.914 | 1.958 | 1.326 | -0.217 | 0.032 | 4.25 | 0.02 |
| -36 | -2.376 | 0 | 1.148 | 1.927 | 1.97 | 1.309 | -0.226 | 0.032 | 4.51 | 0.02 |
| -38 | -2.508 | 0 | 1.131 | 1.94 | 1.981 | 1.293 | -0.236 | 0.032 | 4.77 | 0.02 |
| -40 | -2.64 | 0 | 1.114 | 1.952 | 1.993 | 1.276 | -0.246 | 0.032 | 5.03 | 0.01 |
| -42 | -2.772 | 0 | 1.096 | 1.964 | 2.004 | 1.258 | -0.255 | 0.032 | 5.3 | 0.01 |

Table 3. Gimbal Deflection with Mirror Coil Current = 0 mA

| EAST-WEST CURRENT (mA) | NORTH-SOUTH CURRENT (mA) | NORTH-SOUTH VOLTAGE (V) | NW DETECTOR OUT (V) | NE DETECTOR OUT (V) | SE DETECTOR OUT (V) | SW DETECTOR OUT (V) | IPFx WITH NORTH-SOUTH MOTION | IPFy WITH NORTH-SOUTH MOTION | EAST-WEST ANGLE (deg) | NORTH-SOUTH ANGLE (deg) |
|------------------------|--------------------------|-------------------------|---------------------|---------------------|---------------------|---------------------|------------------------------|------------------------------|-----------------------|-------------------------|
| 0 | 0 | 0.000 | 1.444 | 1.652 | 1.726 | 1.588 | -0.054 | 0.034 | -0.04 | 0.02 |
| 0 | 2 | 0.131 | 1.464 | 1.672 | 1.712 | 1.573 | -0.054 | 0.023 | -0.03 | 0.3 |
| 0 | 4 | 0.261 | 1.485 | 1.692 | 1.697 | 1.556 | -0.054 | 0.012 | -0.03 | 0.57 |
| 0 | 6 | 0.392 | 1.504 | 1.712 | 1.681 | 1.539 | -0.054 | 0.001 | -0.03 | 0.84 |
| 0 | 8 | 0.522 | 1.524 | 1.73 | 1.663 | 1.521 | -0.054 | -0.011 | -0.02 | 1.12 |
| 0 | 10 | 0.653 | 1.543 | 1.749 | 1.645 | 1.502 | -0.054 | -0.022 | -0.01 | 1.41 |
| 0 | 12 | 0.784 | 1.561 | 1.767 | 1.626 | 1.483 | -0.054 | -0.034 | 0 | 1.68 |
| 0 | 14 | 0.914 | 1.579 | 1.784 | 1.607 | 1.464 | -0.054 | -0.046 | 0 | 1.97 |
| 0 | 16 | 1.045 | 1.597 | 1.801 | 1.588 | 1.445 | -0.054 | -0.057 | 0.01 | 2.26 |
| 0 | 18 | 1.175 | 1.615 | 1.818 | 1.57 | 1.425 | -0.054 | -0.068 | 0.02 | 2.54 |
| 0 | 20 | 1.306 | 1.632 | 1.835 | 1.553 | 1.406 | -0.054 | -0.079 | 0.03 | 2.82 |
| 0 | 22 | 1.437 | 1.649 | 1.852 | 1.537 | 1.387 | -0.055 | -0.09 | 0.05 | 3.11 |
| 0 | 24 | 1.567 | 1.666 | 1.868 | 1.521 | 1.369 | -0.055 | -0.1 | 0.06 | 3.4 |
| 0 | 26 | 1.698 | 1.682 | 1.883 | 1.504 | 1.352 | -0.055 | -0.11 | 0.07 | 3.68 |
| 0 | 28 | 1.828 | 1.699 | 1.899 | 1.487 | 1.334 | -0.055 | -0.121 | 0.09 | 3.98 |
| 0 | 30 | 1.959 | 1.716 | 1.915 | 1.47 | 1.315 | -0.055 | -0.132 | 0.11 | 4.27 |
| 0 | 32 | 2.090 | 1.732 | 1.93 | 1.453 | 1.296 | -0.055 | -0.142 | 0.13 | 4.58 |
| 0 | 34 | 2.220 | 1.749 | 1.946 | 1.435 | 1.279 | -0.055 | -0.153 | 0.15 | 4.88 |
| 0 | 36 | 2.351 | 1.766 | 1.962 | 1.418 | 1.26 | -0.055 | -0.164 | 0.18 | 5.19 |
| 0 | -2 | -0.131 | 1.426 | 1.634 | 1.743 | 1.606 | -0.054 | 0.045 | -0.04 | -0.25 |
| 0 | -4 | -0.261 | 1.408 | 1.615 | 1.76 | 1.625 | -0.054 | 0.056 | -0.04 | -0.52 |
| 0 | -6 | -0.392 | 1.388 | 1.596 | 1.776 | 1.642 | -0.053 | 0.068 | -0.04 | -0.8 |
| 0 | -8 | -0.522 | 1.369 | 1.577 | 1.793 | 1.659 | -0.053 | 0.079 | -0.05 | -1.06 |
| 0 | -10 | -0.653 | 1.349 | 1.558 | 1.808 | 1.674 | -0.054 | 0.09 | -0.05 | -1.33 |
| 0 | -12 | -0.784 | 1.329 | 1.539 | 1.823 | 1.689 | -0.054 | 0.101 | -0.04 | -1.62 |
| 0 | -14 | -0.914 | 1.31 | 1.521 | 1.836 | 1.703 | -0.054 | 0.111 | -0.04 | -1.89 |
| 0 | -16 | -1.045 | 1.291 | 1.503 | 1.849 | 1.716 | -0.054 | 0.122 | -0.04 | -2.17 |
| 0 | -18 | -1.175 | 1.272 | 1.483 | 1.863 | 1.73 | -0.054 | 0.132 | -0.04 | -2.45 |
| 0 | -20 | -1.306 | 1.253 | 1.462 | 1.877 | 1.745 | -0.054 | 0.143 | -0.03 | -2.72 |
| 0 | -22 | -1.437 | 1.233 | 1.44 | 1.891 | 1.758 | -0.054 | 0.154 | -0.02 | -3.01 |
| 0 | -24 | -1.567 | 1.213 | 1.419 | 1.905 | 1.772 | -0.054 | 0.166 | -0.01 | -3.29 |
| 0 | -26 | -1.698 | 1.193 | 1.396 | 1.919 | 1.785 | -0.053 | 0.177 | -0.01 | -3.57 |
| 0 | -28 | -1.828 | 1.173 | 1.371 | 1.932 | 1.798 | -0.053 | 0.189 | 0 | -3.86 |
| 0 | -30 | -1.959 | 1.152 | 1.346 | 1.945 | 1.81 | -0.053 | 0.201 | 0.02 | -4.15 |
| 0 | -32 | -2.090 | 1.131 | 1.322 | 1.958 | 1.823 | -0.052 | 0.213 | 0.03 | -4.45 |
| 0 | -34 | -2.220 | 1.111 | 1.298 | 1.971 | 1.835 | -0.052 | 0.225 | 0.04 | -4.74 |
| 0 | -36 | -2.351 | 1.091 | 1.276 | 1.983 | 1.846 | -0.052 | 0.236 | 0.05 | -5.04 |
| 0 | -38 | -2.481 | 1.07 | 1.255 | 1.995 | 1.858 | -0.052 | 0.247 | 0.07 | -5.34 |

7. Plots of the IPF parameters versus mirror position can then be constructed as shown in [Figure 3](#).

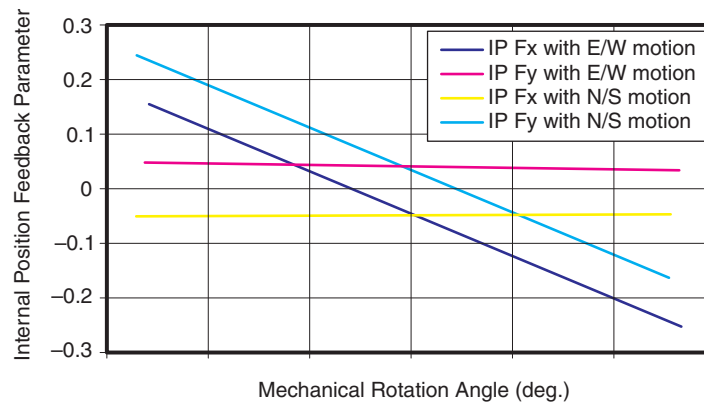

Figure 3. Position Feedback

8. This process constitutes a mapping between the mirror position space (angle of rotation) and the IPF space (IPFx and IPFy parameters). With this mapping, one can now use the IPF parameters to determine mirror position. The IPF parameters can also be used as inputs for a control loop to reduce unwanted motion of the mirror (ringing) with step current inputs into the coils. Note that, for this example, the IPF parameter mapping was done only for independent motion of the mirror (East-West) and gimbals (North-South). In some cases it may be beneficial to extend the mapping along lines with both mirror and gimbals motion so that the gap between extrapolated points is smaller.

3 Frequently Asked Question

- What precautions should be taken when handling the mirror?
Use handling techniques appropriate for precision optical components. The mirror hinges are robust to shocks of 500G but the hinges are thin and can not withstand direct contact to the mirror. The rare earth magnets on the mirror are very strong and will be attracted to ferromagnetic material such as iron or nickel containing tools; be sure to keep such tools at a distance of at least inch from the mirror.
- Should a voltage or current source drive circuit be used?
The choice of a voltage or current source drive depends on the application but the current source has the advantage of better thermal stability. The variation of the coil resistance with temperature will cause variations in the angle versus voltage curves over temperature which is undesirable for most applications.
- How do I use the temperature sensor to measure temperature?
The datasheet for the temperature can be found by following this link:
<http://www.alldatasheet.com/datasheet-pdf/pdf/8986/NSC/LM61.html> .

IMPORTANT NOTICE

Texas Instruments Incorporated and its subsidiaries (TI) reserve the right to make corrections, modifications, enhancements, improvements, and other changes to its products and services at any time and to discontinue any product or service without notice. Customers should obtain the latest relevant information before placing orders and should verify that such information is current and complete. All products are sold subject to TI's terms and conditions of sale supplied at the time of order acknowledgment.

TI warrants performance of its hardware products to the specifications applicable at the time of sale in accordance with TI's standard warranty. Testing and other quality control techniques are used to the extent TI deems necessary to support this warranty. Except where mandated by government requirements, testing of all parameters of each product is not necessarily performed.

TI assumes no liability for applications assistance or customer product design. Customers are responsible for their products and applications using TI components. To minimize the risks associated with customer products and applications, customers should provide adequate design and operating safeguards.

TI does not warrant or represent that any license, either express or implied, is granted under any TI patent right, copyright, mask work right, or other TI intellectual property right relating to any combination, machine, or process in which TI products or services are used. Information published by TI regarding third-party products or services does not constitute a license from TI to use such products or services or a warranty or endorsement thereof. Use of such information may require a license from a third party under the patents or other intellectual property of the third party, or a license from TI under the patents or other intellectual property of TI.

Reproduction of TI information in TI data books or data sheets is permissible only if reproduction is without alteration and is accompanied by all associated warranties, conditions, limitations, and notices. Reproduction of this information with alteration is an unfair and deceptive business practice. TI is not responsible or liable for such altered documentation. Information of third parties may be subject to additional restrictions.

Resale of TI products or services with statements different from or beyond the parameters stated by TI for that product or service voids all express and any implied warranties for the associated TI product or service and is an unfair and deceptive business practice. TI is not responsible or liable for any such statements.

TI products are not authorized for use in safety-critical applications (such as life support) where a failure of the TI product would reasonably be expected to cause severe personal injury or death, unless officers of the parties have executed an agreement specifically governing such use. Buyers represent that they have all necessary expertise in the safety and regulatory ramifications of their applications, and acknowledge and agree that they are solely responsible for all legal, regulatory and safety-related requirements concerning their products and any use of TI products in such safety-critical applications, notwithstanding any applications-related information or support that may be provided by TI. Further, Buyers must fully indemnify TI and its representatives against any damages arising out of the use of TI products in such safety-critical applications.

TI products are neither designed nor intended for use in military/aerospace applications or environments unless the TI products are specifically designated by TI as military-grade or "enhanced plastic." Only products designated by TI as military-grade meet military specifications. Buyers acknowledge and agree that any such use of TI products which TI has not designated as military-grade is solely at the Buyer's risk, and that they are solely responsible for compliance with all legal and regulatory requirements in connection with such use.

TI products are neither designed nor intended for use in automotive applications or environments unless the specific TI products are designated by TI as compliant with ISO/TS 16949 requirements. Buyers acknowledge and agree that, if they use any non-designated products in automotive applications, TI will not be responsible for any failure to meet such requirements.

Following are URLs where you can obtain information on other Texas Instruments products and application solutions:

Products

| | |
|-----------------------------|--|
| Amplifiers | amplifier.ti.com |
| Data Converters | dataconverter.ti.com |
| DLP® Products | www.dlp.com |
| DSP | dsp.ti.com |
| Clocks and Timers | www.ti.com/clocks |
| Interface | interface.ti.com |
| Logic | logic.ti.com |
| Power Mgmt | power.ti.com |
| Microcontrollers | microcontroller.ti.com |
| RFID | www.ti-rfid.com |
| RF/IF and ZigBee® Solutions | www.ti.com/lprf |

Applications

| | |
|--------------------|--|
| Audio | www.ti.com/audio |
| Automotive | www.ti.com/automotive |
| Broadband | www.ti.com/broadband |
| Digital Control | www.ti.com/digitalcontrol |
| Medical | www.ti.com/medical |
| Military | www.ti.com/military |
| Optical Networking | www.ti.com/opticalnetwork |
| Security | www.ti.com/security |
| Telephony | www.ti.com/telephony |
| Video & Imaging | www.ti.com/video |
| Wireless | www.ti.com/wireless |

Mailing Address: Texas Instruments, Post Office Box 655303, Dallas, Texas 75265
Copyright © 2009, Texas Instruments Incorporated