



TRESTLE TABLE

Plans and Instruction



Index

The Legs	3
Center of the Leg	4
Bottom Feet	5
Upper Table Support	6
Assembly of the Legs	7
Center Stretcher	8
Tusk Mortise	9
Upper Support Rail	10
Glue up the Base	11
The Tusks	12
The Top	13
Breadboard Ends	14
The Drawbore	15
Shaping the Top	16
Bottom Chamfer / Mount the Top	17
The Finish	18



The Legs

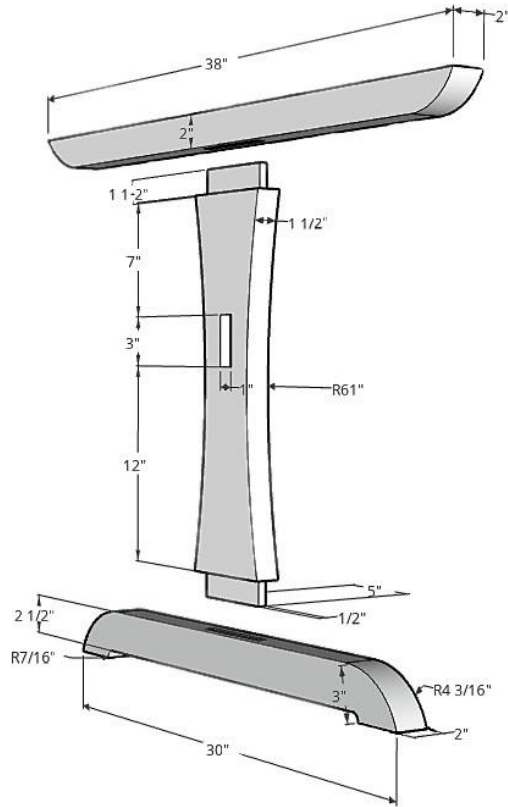

The legs are comprised of 3 individual pieces that are assembled using Mortise and Tenon joinery.

The material of choice on this project is Poplar. Although the plan is to paint this base, this material could easily be replaced with your species of choice.

There are no specialty woodworking tools to Create this leg.

The Center of the Leg

The final stock material for the leg is 25" long, 6" wide, and 1 1/2" thick.

To get the mortise, rip the stock lengthwise and glue in 1" blocks leaving the 3" needed for the center stretcher at the locations indicated in the plans.

Cut the tenons on each end. Centered tenons are 1 1/2" long, 5" wide, and 1/2" thick.

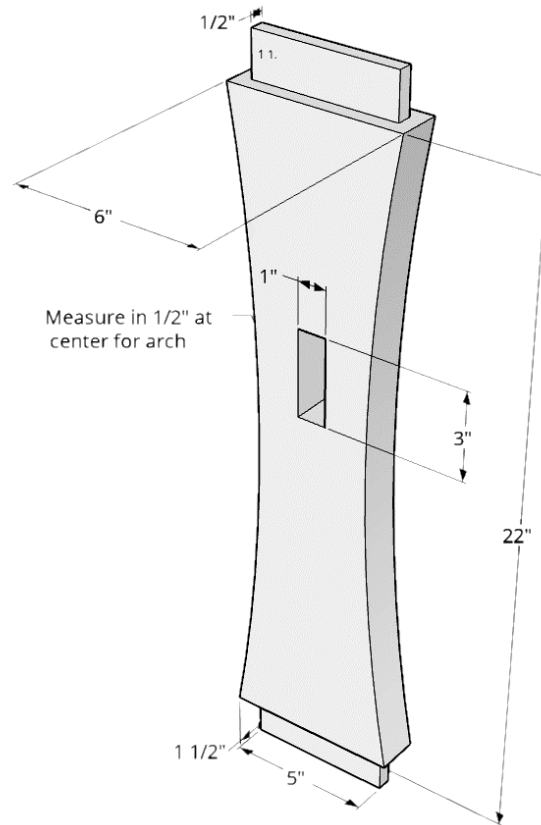

To cut the curves, locate center along the length (approximately 12 1/2") and measure in 1/2".

Draw an arc connecting the 3 points and cut.

Add edge treatments of your choosing to only the curved part of the legs.

Bottom Feet

The Final stock for the feet is 30" long, 3" wide, and 2" thick.

To create the foot pads, measure in 3" from each end and strike a line. Measure up 1/2" and create a radius of your choosing. Remove the material in the middle.

Create a centered mortise that is 5" wide by 1/2" to accept the tenon cut in the previous step.

The outer curves are cut to a 4 3/16" radius. This radius can be changed to meet your preference.

Apply edge treatments to all sides.

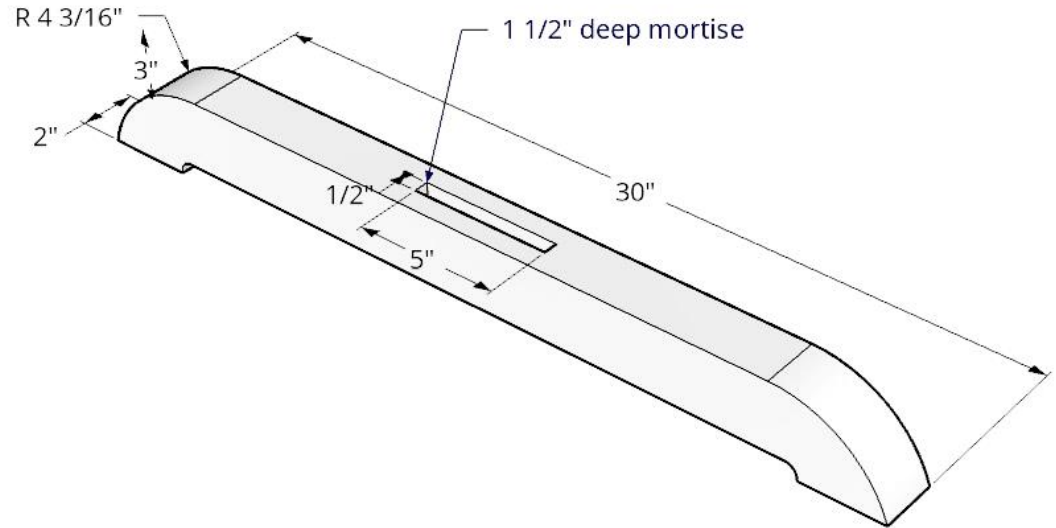

Upper Table Support

The Final stock for the feet is 38" long, 2" wide, and 2" thick.

Create a centered mortise that is 5" wide by 1/2" to accept the tenon cut in the previous step.

The outer curves are cut to meet your preference.

Apply edge treatments to the mortise side of the support rail only.

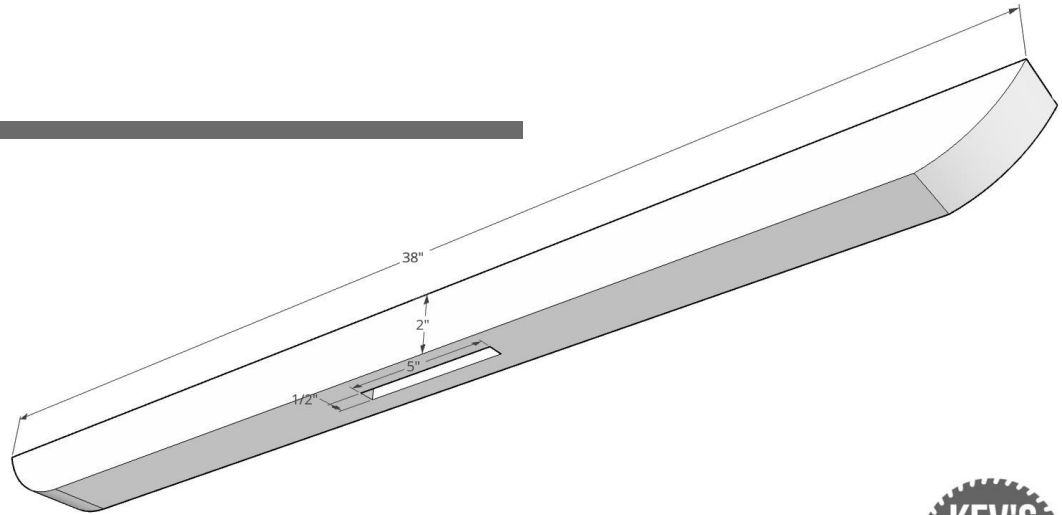

Assembly of the Legs

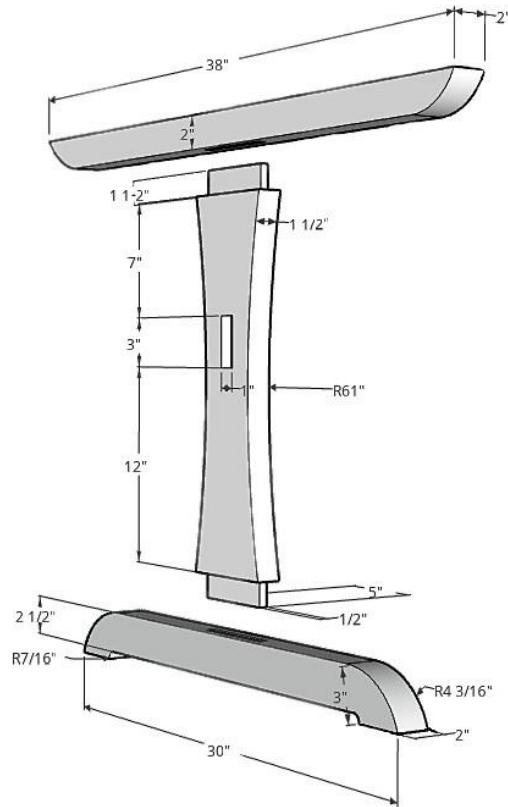

Ensure that the tenons fit properly into the mortises created in the previous steps.

Apply glue and appropriate clamps and allow to cure

Once glue is fully cured, remove from clamps, sand, and prepare for finish.

The Final stock for the center stretcher is 50 3/4" long, 4" wide, and 2" thick.

Center Stretcher

Create centered tenons on each end that are 3 1/8" long, 3" wide, and 1" thick. Ensure these fit properly into the mortises created in the legs.

Measure up 1" at the center of the stretcher to create the arc. This can be cut and sanded at this point.

Create centered tenons on each end that are 3 1/8" long, 3" wide, and 1" thick. Ensure these fit properly into the mortises created in the legs.

Mortises should be 1/2" from the end, 1 1/4" long, and 3/8" wide.

Add an angled mortise wall to the outside edge of each mortise.

The angle should be ~7 degrees. Whatever angle you choose will be needed later to create the tusks.

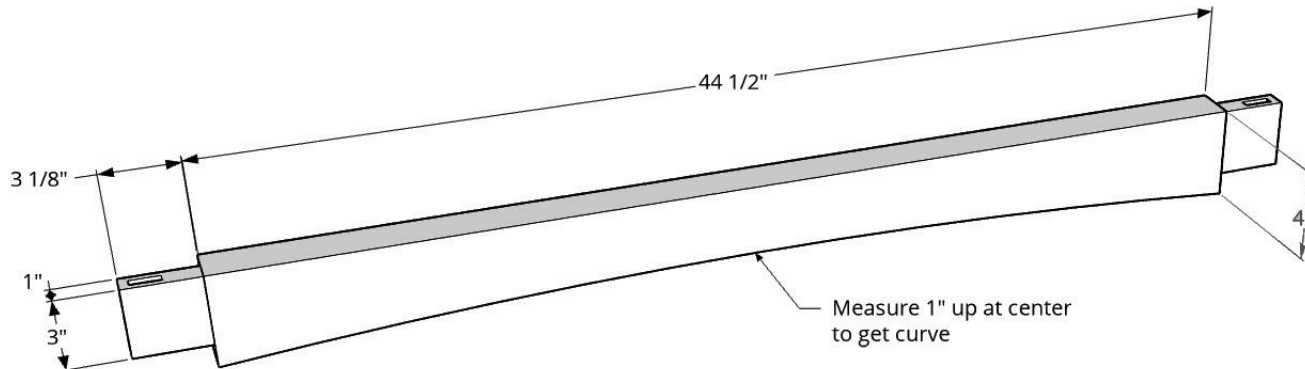

Tusk Mortise

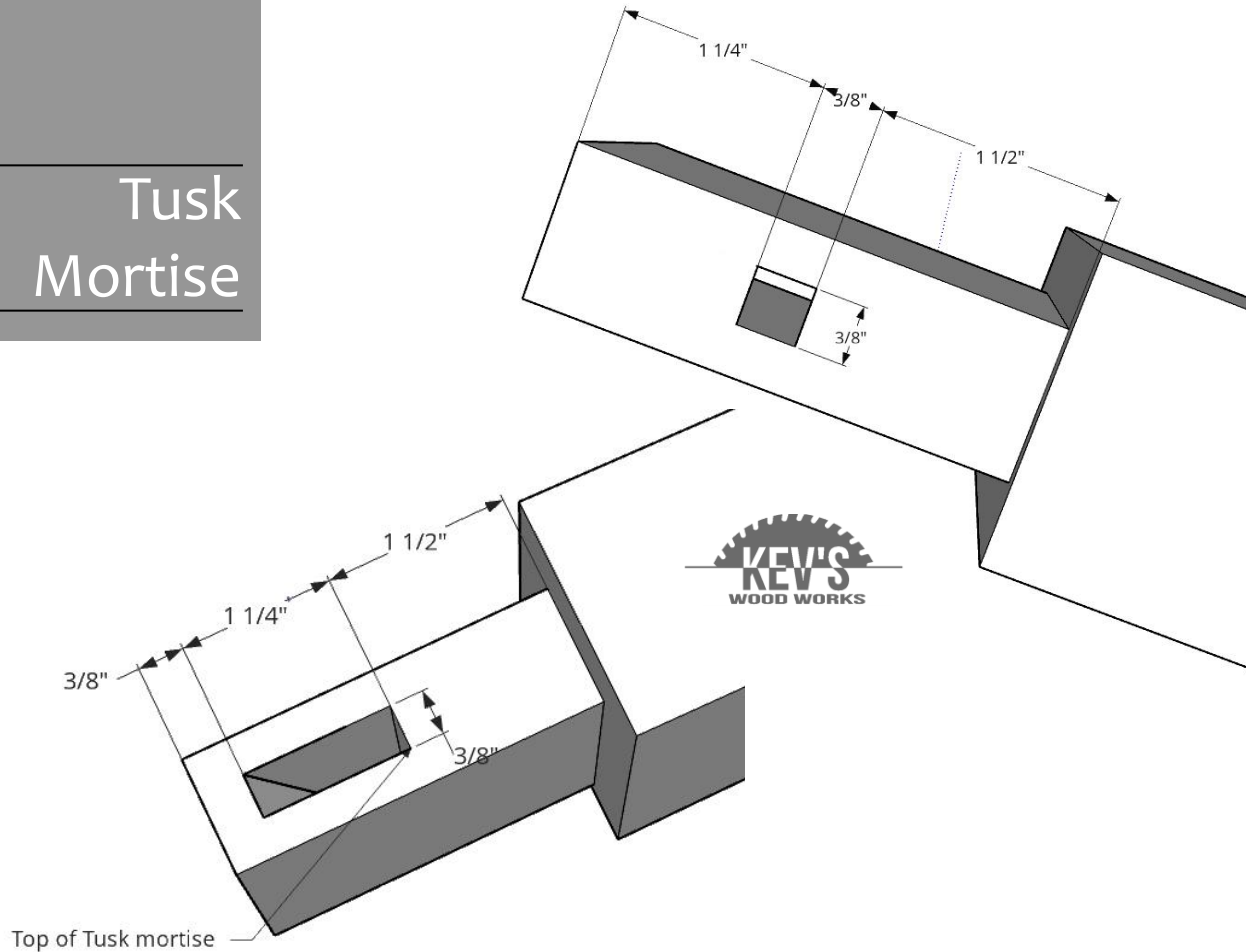

The layout for the tusk mortise is different on the top and the bottom.

This is to account for the ~7 degree taper on the tusks.

Cut mortises ensuring that the taper is in place.

Ensure that the back of the mortise fits flush with the leg center mortise.

Upper Support Rail

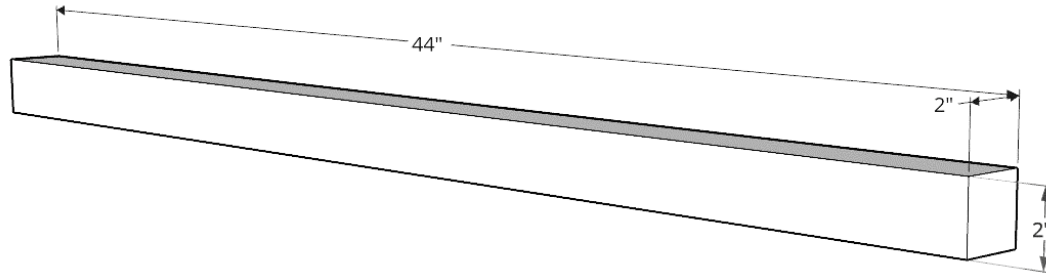

The Final stock for the upper support rail is 44” long, 2” wide, and 2” thick.

Note: If you’re using traditional Mortise and Tenon joinery here, allow extra length to account for that joinery.

Locate domino location on the upper support rail as well as the upper table support.

Apply edge treatments to the bottom side of the support rail only.



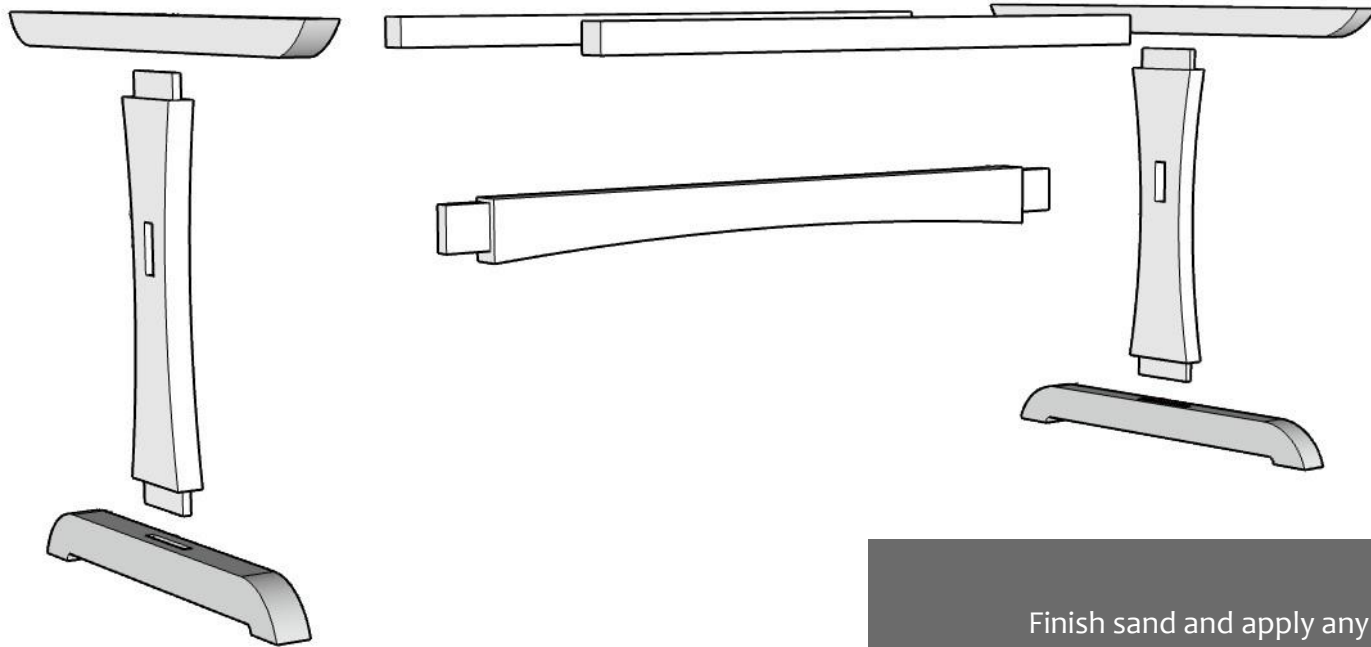

Glue Up the Base

Glue up and clamp the base.
Finish sand and apply any edge treatments in previous steps.

The Tusks

The final stock for the tusks should be 7" long, 1 1/2" wide, and 3/8" thick.

Material of choice:
either match the top or the base.

Cut the angle previously used in the stretcher tenons on one long side of the tusk.

Apply round or profile of choice on the upper front corner.

Ensure a proper fit and make any corrections necessary.

Sand any sharp edges and prep for finish.

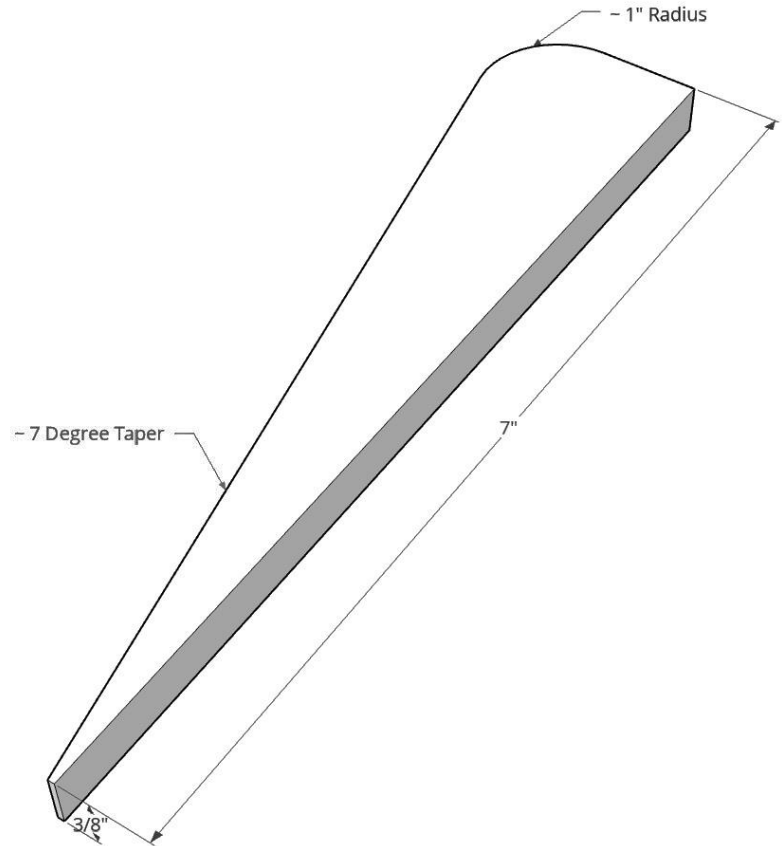

The Top

Preparing for the Breadboard Ends

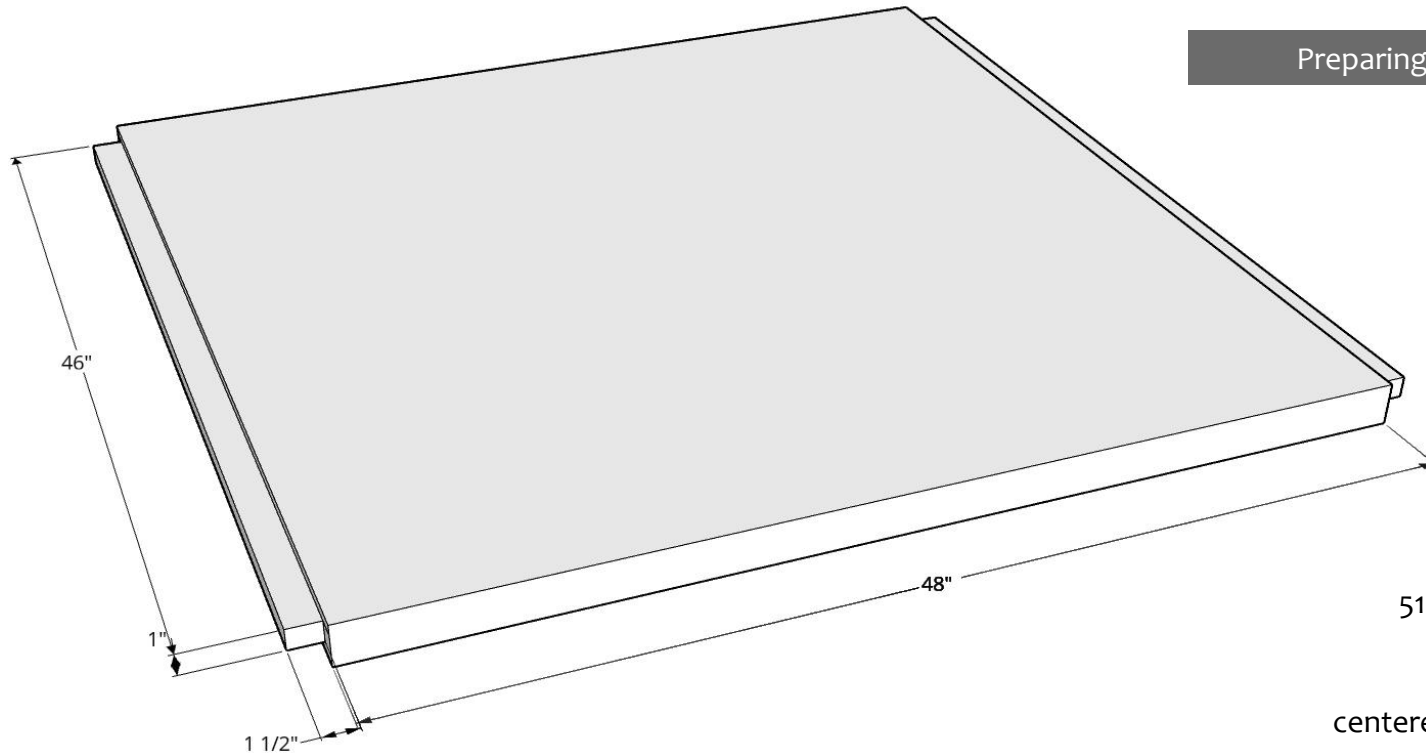

The final stock for the top is 51" long, 48" wide, and 2" thick.

Create a 1" tenon on each end centered on the thickness of the top.

Remove 1" from each end of the tenon. This will be covered by the Breadboard end in a future step.

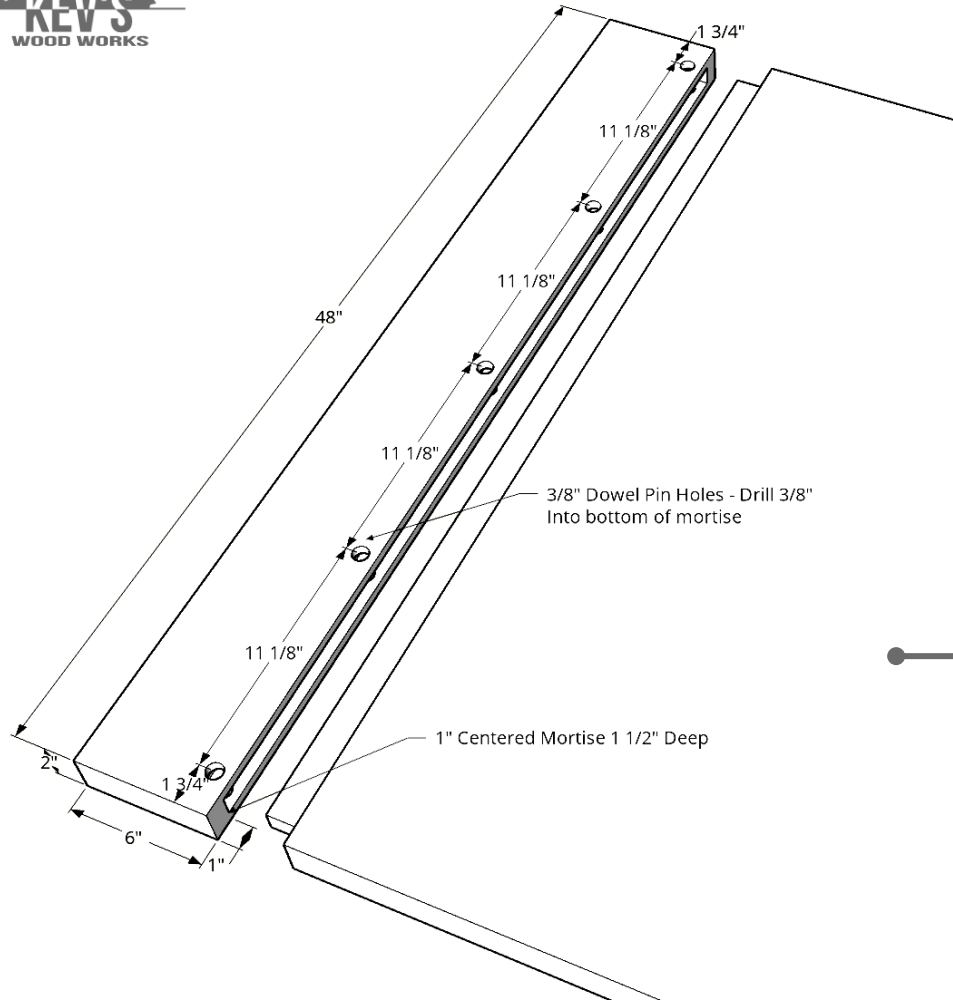

Breadboard Ends

●————● The final stock for the Breadboard ends is 48" long, 6" wide, and 2" thick.

●————● Create a 1" centered mortise that is 1 1/2" deep. The mortise starts and stops 1" from each end. Ensure this mortise fits on the tenon created on the tabletop.

●————● Locate the 3/8" dowel pin locations and drill to a depth of 3/8" into the bottom of the mortise. Don't drill all the way through and do not drill these holes in the tenon since a draw bore tenon method will be used.

The Drawbore

Dry fit the breadboard ends on the tabletop and clamp in place.

↪ Use a $\frac{3}{8}$ " brad point bit to locate placement on the tabletop tenon.

Don't drill.

Remove the breadboard end and mark the center locations $\frac{1}{16}$ " closer to the shoulder of the tabletop. Drill these locations.

↪ Elongate all the holes except for the center hole. Do not elongate this hole. *Only elongate side to side adding about $\frac{1}{8}$ " to $\frac{3}{16}$ " to the width.*

Apply glue to the center section only, install the breadboard and clamp in place.

↪ Install the pins and allow glue to dry. *The outer pins may seem difficult to drive in but, they will go.*

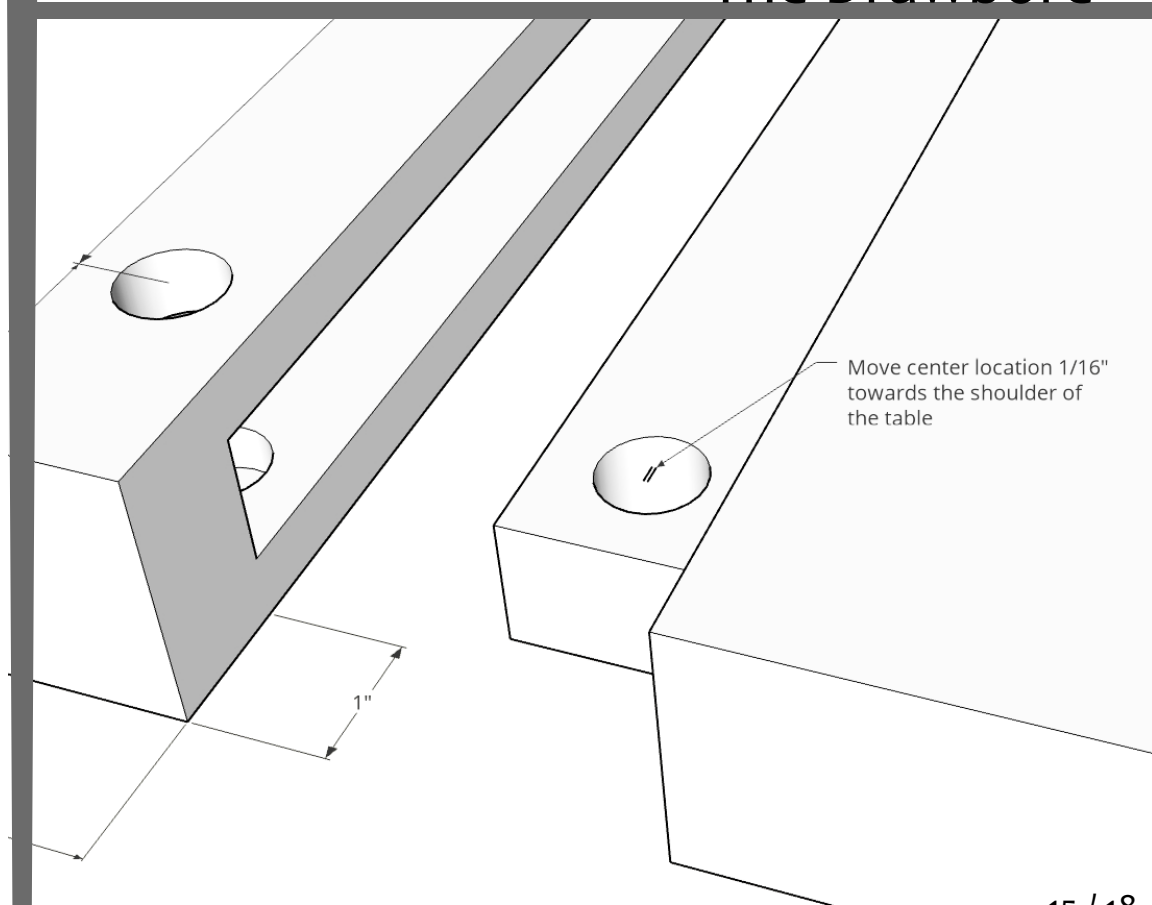

Shaping The Top

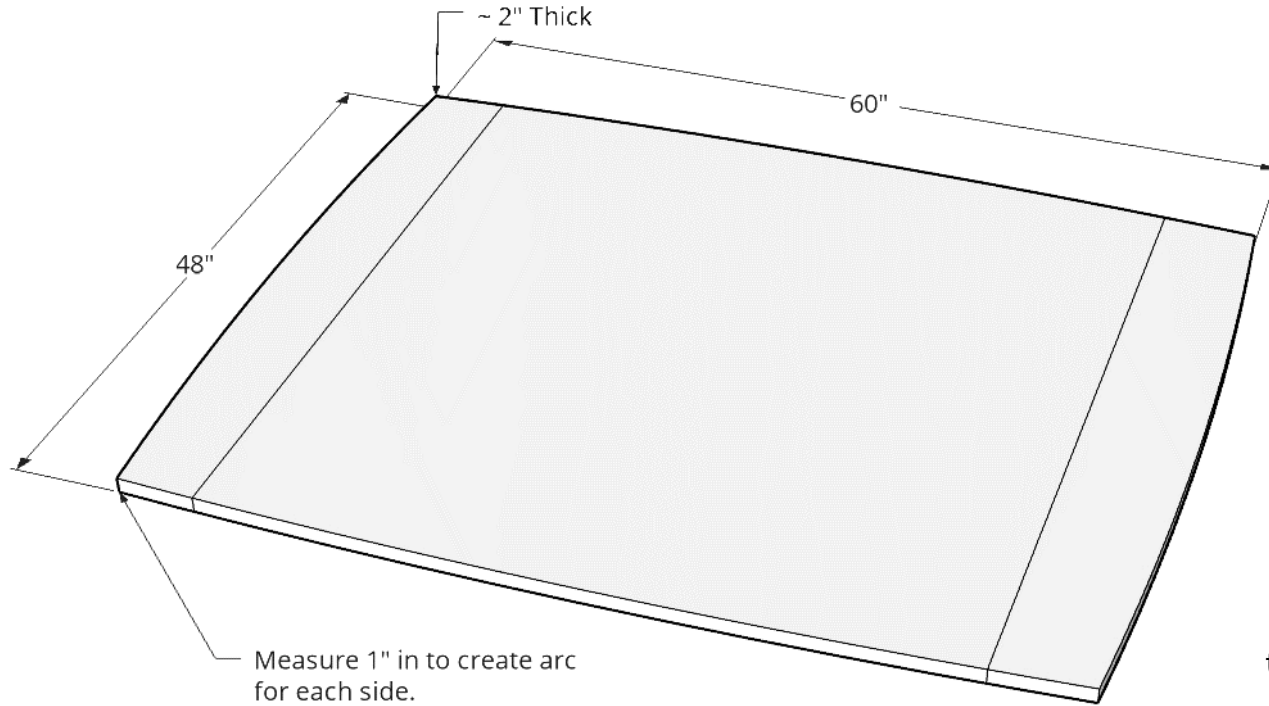

Measure in ~1" from each corner and make a mark. Locate the center of each side. Use these marks to create the curve.

Note: This is a decorative element and may be changed to fit your table..

Cut and sand to your lines.

Note: Another method would be to create a template for each side to mark the lines. Cut close to the lines and then use the template to flush trim.

Apply desired edge treatment to the tabletop.

The Bottom Chamfer

Draw a line ~1" down from the top.

Draw another line ~1 1/2" in from the side.

Shape the chamfer.

Note: This can be done with a handheld power planer, power carved, or done by hand.

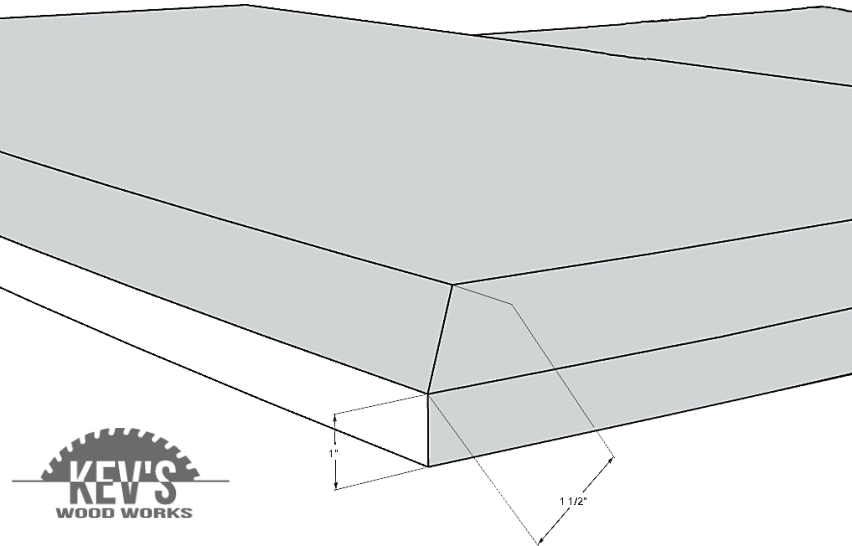

Mount the Top

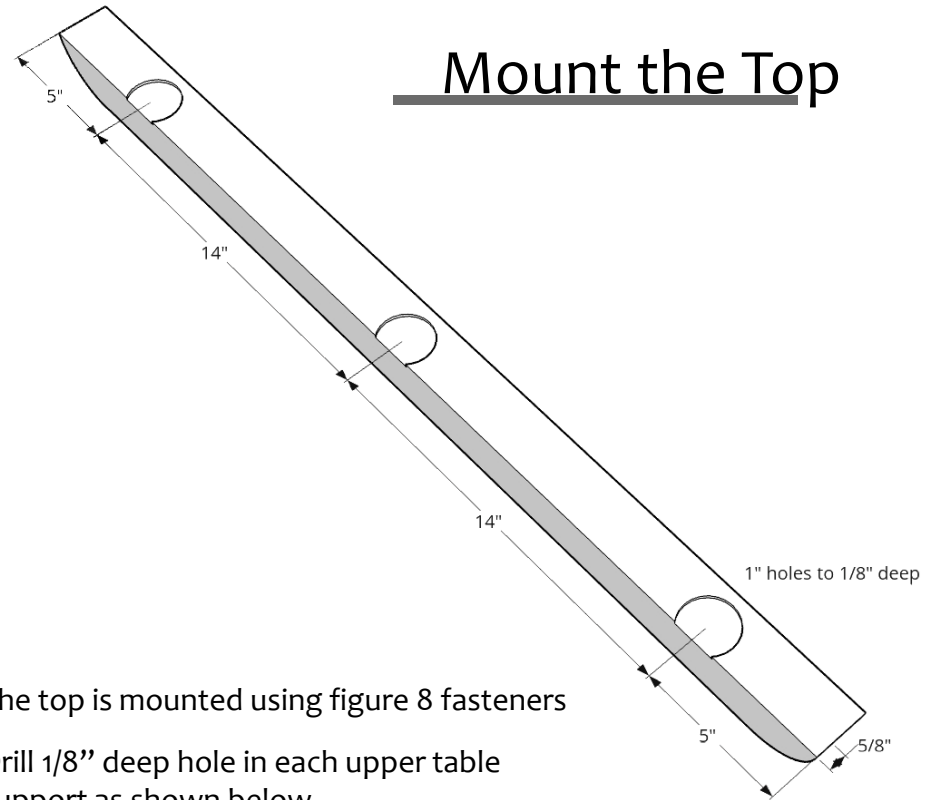

The top is mounted using figure 8 fasteners

Drill 1/8" deep hole in each upper table support as shown below.

Use a #8 screw to fasten them to the table support

Note: Ensure that the Figure 8s are oriented towards the center of the table.



The Finish

Finish sand and apply finish of choice.

