

# CHAPTER 11

## WIRE ROPE AND SLINGS

This chapter provides requirements for the fabrication and use of wire rope and slings used in hoisting and rigging and implements the requirements of ASME B30.9, Slings (for latest ASME standards, see <http://catalog.asme.org/home.cfm?Category=CS>).

11.1	GENERAL .....	11-1
11.2	WIRE ROPE .....	11-4
11.2.1	Wire-Rope Lays .....	11-4
11.2.2	Wire-Rope Cores .....	11-4
11.2.3	Wire Rope for General Purposes .....	11-4
11.2.3.1	6 x 19 Classification .....	11-4
11.2.3.2	6 x 37 Classification .....	11-5
11.2.4	Wire-Rope Inspections .....	11-5
11.2.5	Wire-Rope Maintenance .....	11-5
11.3	SLINGS .....	11-8
11.3.1	General .....	11-8
11.3.1.1	Load Angle Factor .....	11-8
11.3.1.2	Safe Load .....	11-8
11.3.1.3	Design Factor .....	11-10
11.3.1.4	Sling Care .....	11-10
11.3.1.5	Sling Storage .....	11-10
11.3.1.6	Inspections .....	11-10
11.3.1.7	Sling Periodic Inspection Records .....	11-10
11.3.2	Wire-Rope Slings .....	11-10
11.3.2.1	Removal from Service Criteria .....	11-20
11.3.2.2	Proof-Testing .....	11-20
11.3.2.3	Operation .....	11-20
11.3.2.4	Critical Lifts .....	11-24
11.3.3	Alloy Steel-Chain Slings .....	11-25
11.3.3.1	Removal from Service Criteria .....	11-25
11.3.3.2	Proof-Testing .....	11-26
11.3.3.3	Operation .....	11-28
11.3.3.4	Critical Lifts .....	11-29
11.3.4	Metal-Mesh Slings .....	11-29
11.3.4.1	Removal from Service Criteria .....	11-32
11.3.4.2	Proof-Testing .....	11-32
11.3.4.3	Operation .....	11-32
11.3.4.4	Critical Lifts .....	11-33
11.3.5	Synthetic-Web Slings .....	11-33
11.3.5.1	Removal from Service Criteria .....	11-36
11.3.5.2	Proof-Testing .....	11-36
11.3.5.3	Operation .....	11-40
11.3.5.4	Critical Lifts .....	11-40
11.3.6	Synthetic Roundslings .....	11-40
11.3.6.1	Removal from Service Criteria .....	11-41
11.3.6.2	Proof-Testing .....	11-42
11.3.6.3	Operation .....	11-42
11.3.6.4	Critical Lifts .....	11-43

INTENTIONALLY BLANK

---

## 11.1 GENERAL

---

- a. The information in this section provides guidance for safely handling lifted loads. Diagrams are used to illustrate hoisting and rigging principles and good and bad rigging practices. This is not a rigging textbook; the information should be applied only by qualified riggers.
- b. Wire rope and slings that have been irreversibly damaged or removed from service shall be made unusable for hoisting and rigging operations before being discarded.
- c. Load tables are representative only and are not exact for all materials or all manufacturers.
- d. Prior to rigging a load, determine the weight of the load:
1. From markings on the load.
  2. By weighing, if the load is still on a truck or railroad car.
  3. From drawings or other documentation.
  4. By calculation, using the load dimensions and the weights of common materials in Table 11-1.
- e. Determine the center of gravity of the load as accurately as possible:
1. From drawings or other documentation.
  2. From markings on the load.
  3. By calculation.
- f. Determine the best method to attach the load and select the appropriate lifting devices (e.g., wire-rope, steel-chain, metal-mesh, or synthetic-web slings).
- g. Bending a wire rope over a fixed object such as a pin or a shackle has an effect on the capacity of the rope: the outside wires and strands of a bend have to stretch farther and therefore take a greater percentage of the load.
- h. There is a convenient method for estimating the efficiency of the rope as it passes over the bend. This method uses the ratio (R) of the diameter (D) of the object (sheave, pin, corner) about which the wire rope is being bent to the diameter (d) of the rope. The efficiency of the bend can then be estimated using the formula shown in Figure 11-1. Note that the efficiency decreases quickly as the ratio of the diameters decreases.
- i. Aside from efficiency, there are other reasons to avoid sharp bends in wire rope including physical damage to the rope, reduction of service life, and damage to the object about which the rope is bent.
- j. When the ratio of the diameter of the bend to the nominal rope diameter (D/d ratio) is small, the strength efficiency factor is lower than when the D/d ratio is relatively large. Load tables do not take into account such factors as abnormal temperatures, excessive corrosion, and vibration.
- k. Determine the appropriate ratings of the device to be used, allowing for:
1. *The number of sling legs* – Note that a sling leg completely doubled back on itself constitutes two sling legs.
  2. *The angle between the horizontal surface of the load and the sling leg* – The smaller the angle, the smaller the lifting capacity of the equipment
  3. *Wear* – The reduction in strength of the equipment due to normal wear.
- l. The working load limit (WLL) of wire ropes and slings shall not be exceeded in their as configured application.

Table 11-1. Weights of Common Materials.

Name of Metal	Weight (lb/ft <sup>3</sup> )	Name of Metal	Weight (lb/ft <sup>3</sup> )
Aluminum	166	Bluestone	160
Antimony	418	Brick, pressed	150
Bismuth	613	Brick, common	125
Brass, cast	504	Cement, Portland (packed)	100-120
Brass, rolled	523	Cement, Portland (loose)	70-90
Copper, cast	550	Cement, slag (packed)	80-100
Copper, rolled	555	Cement, slag (loose)	55-75
Gold, 24-carat	1,204	Chalk	156
Iron, Cast	450	Charcoal	15-34
Iron, wrought	480	Cinder concrete	110
Lead, commercial	712	Clay, ordinary	120-150
Mercury, 60 degrees F	846	Coal, hard, solid	93.5
Silver	655	Coal, hard, broken	54
Steel	490	Coal, soft, solid	84
Tin, cast	458	Coal, soft, broken	54
Uranium	1,163	Coke, loose	23-32
Zinc	437	Concrete or stone	140-155
		Earth, rammed	90-100
<b><u>Name of wood</u></b>		Granite	165-170
		Gravel	117-125
Ash	35	Lime, quick (ground loose)	53
Beech	37	Limestone	170
Birch	40	Marble	164
Cedar	22	Plaster of paris (cast)	80
Cherry	30	Sand	90-106
Chestnut	26	Sandstone	151
Cork	15	Shale	162
Cypress	27	Slate	160-180
Ebony	71	Terra-cotta	110
Elm	30	Traprock	170
Fir, Balsam	22	Water	65
Hemlock	31		
Maple, Oak	62		
Pine, Poplar	30		

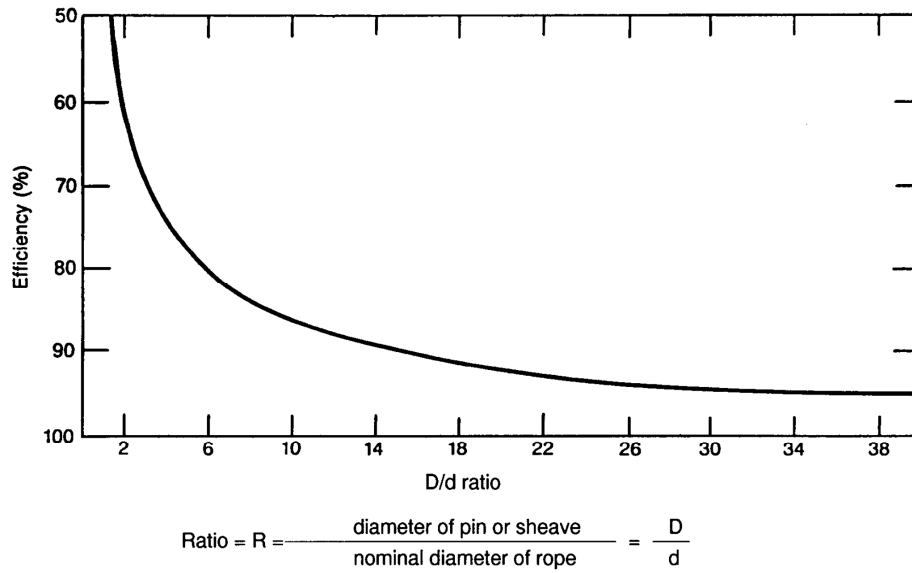

Figure 11-1. Efficiency of wire rope when bent and statically loaded to destruction over sheaves and pins of various diameters.

## 11.2 WIRE ROPE

### 11.2.1 WIRE-ROPE LAYS

- In a right-lay rope, the strands twist to the right around the core like a conventional screw thread; in a left-lay rope, the strands twist to the left.
- A rope has a lang lay when the strands and the individual wires have the same lay direction. When the strands and the wires have an opposite lay direction, the rope has a regular lay.
- A standard wire rope, unless otherwise stated, is understood to be right regular lay. With few exceptions, all wire rope is made right lay. Left-lay rope is a special-purpose rope.
- Figure 11-2 shows ropes with right and left lays combined with regular and lang lays.
- Lay length is the lengthwise distance measured along a wire rope in which a strand makes one complete revolution about the rope's axis.

- Strand Core – This type of core has a single strand used as the core. This type is generally confined to the smaller ropes as a substitute for IWRC. The strand core may or may not have the same cross section as the surrounding strands.

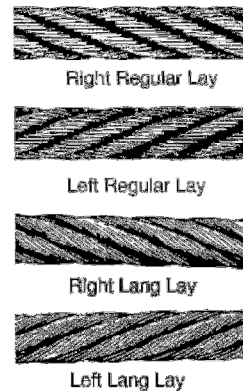

Figure 11-2. Wire-Rope lays.

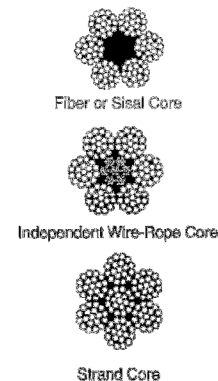

Figure 11-3. Wire-rope cores.

### 11.2.2 WIRE-ROPE CORES

- Wire rope consists of multistrand metal wires wrapped around a suitable core material. Wire-rope cores are carefully designed and must be precisely manufactured to close tolerances to ensure a perfect fit in the rope. The most common types of cores include the following (see Figure 11-3):
  - Fiber Core (FC) or Sisal Core – Sisalanna is the most common fiber that is used in the manufacture of wire-rope cores. In smaller ropes, cotton and jute are sometimes used for the core.
  - Independent Wire-Rope Core (IWRC) – The primary function of the core is to provide adequate support for the strands. As the name implies, an IWRC is a separate small-diameter wire rope that is used as the core for a larger wire rope. When severe crushing or flattening of the rope is encountered, an IWRC is usually specified.

### 11.2.3 WIRE ROPE FOR GENERAL PURPOSES

#### 11.2.3.1 6 x 19 Classification

- Most applications can use a rope from this classification; it is the most versatile of all ropes made. Figure 11-4 shows four varieties of 6 x 19 wire ropes with FCs and IWRCs. Table 11-2 provides breaking strengths for 6 x 19 wire ropes with FC and IWRC cores.

- b. The principle types of ropes in this classification include:

1. 6 x 19F – The most popular and versatile of all wire ropes and the most flexible is the 6 x 19F classification. This rope is considered the perfect compromise between maximum abrasion resistance and maximum flexibility.
2. 6 x 16F – Slightly more abrasion resistant than the 6 x 19F, the 6 x 16F makes an excellent rope for small draglines and similar uses. The resistance to wear is gained by a slight sacrifice in flexibility.
3. 6 x 19 Seale – The 6 x 19 Seale is a rugged wire rope for applications involving heavy wear. Car pullers often use this rope, and it is widely used for slushers and drag scrapers.
4. 6 x 19 Warrington – The alternating large and small outer wires make this rope an all-around performer. The 6 x 19 Warrington is used for general-purpose hoisting, churn drills, and miscellaneous slings.

#### 11.2.3.2 6 x 37 Classification

- a. When sheaves and drums are fairly small and abrasive conditions are not severe, the ropes in this classification will show better performance than the coarser 6 x 19 construction. Under conditions of repeated bending, they will outlast a 6 x 19 rope; when abrasion is severe, the small outer wires quickly show the effect. Figure 11-5 show three varieties of 6 x 37 wire rope with FC and IWRC cores. Table 11-3 provides breaking strengths for 6 x 37 wire ropes with FC and IWRC cores.
- b. The principal types of ropes in this classification include:
  1. 6 x 37 2-operation – A 6 x 37 2-operation strand has 18 outer wires. This construction is used on industrial equipment, for flexible slings, and in miscellaneous hoisting.

2. 6 x 29F – A 6 x 29F is used for applications requiring a flexible rope slightly more resistant to wear than the 6 x 37 2-operation rope.
3. 6 x 41 – A 6 x 41 rope is used widely for ropes over 1-in. diameter in the 6 x 37 classification.

#### 11.2.4 WIRE-ROPE INSPECTIONS

A qualified inspector shall inspect wire ropes at least annually. Inspection requirements vary depending on what type of equipment the wire ropes are used on. Refer to other sections in this standard, based on the equipment being used, for specific inspection requirements.

#### 11.2.5 WIRE-ROPE MAINTENANCE

Personnel using wire rope shall ensure proper care by doing the following:

- a. Store rope to prevent damage or deterioration.
- b. Unreel or uncoil rope as recommended by the rope manufacturer or a qualified person and with care to avoid kinking or inducing a twist.
- c. Before cutting a rope, use some method to prevent unlaying of the strands. Heat-affected zones of flame cut wire rope shall not be allowed to bear load.
- d. During installation, avoid dragging the rope in the dirt or around objects that will scrape, nick, crush, or induce sharp bends.
- e. Unless prohibited by other considerations, maintain rope in a well-lubricated condition. The object of rope lubrication is to reduce internal friction and to prevent corrosion. Ensure that lubricant applied as part of a maintenance program is compatible with the original lubricant and is also a type that does not hinder visual inspection. Those sections of rope in contact with sheaves or otherwise hidden during inspection and maintenance procedures require special attention when lubricating rope.

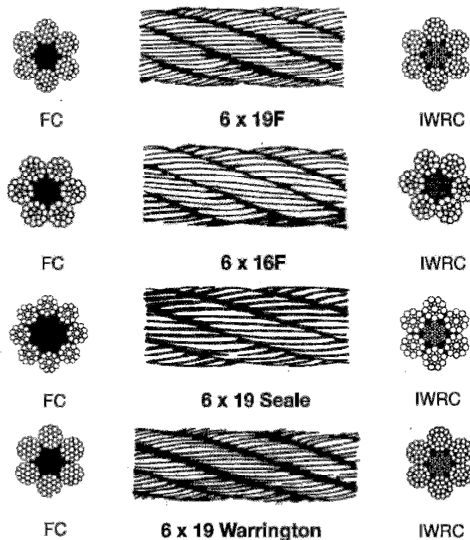

Figure 11-4. 6 x 19 classification of wire rope.

Table 11-2. Breaking strength of wire rope (6 x 19 classification).

Rope diameter (in.)	Weight (lb. per ft.)	Breaking strength in tons of 2,000 lb.		Rope diameter (in.)	Weight (lb. per ft.)	Breaking strength in tons of 2,000 lb.	
		Plow steel	Improved plow steel			Plow steel	Improved plow steel
3/16	0.06	1.3	1.5	3/16	0.07	1.4	1.6
1/4	0.10	2.4	2.7	1/4	0.11	2.6	2.9
5/16	0.16	3.8	4.1	5/16	0.18	4.1	4.4
3/8	0.23	5.4	6.0	3/8	0.25	5.8	6.5
7/16	0.31	7.0	8.0	7/16	0.34	7.5	8.6
1/2	0.40	10.0	11.0	1/2	0.44	10.8	11.8
9/16	0.51	11.7	13.3	9/16	0.56	12.6	14.3
5/8	0.63	15.0	16.5	5/8	0.69	16.1	17.7
3/4	0.90	21.5	23.8	3/4	0.99	23.1	25.6
7/8	1.23	28.3	32.0	7/8	1.35	30.4	34.4
1	1.60	38.0	41.7	1	1.76	40.8	44.8
1 1/8	2.03	48.5	53.0	1 1/8	2.23	52.1	57.0
1 1/4	2.50	60.0	65.0	1 1/4	2.75	64.5	70.4
1 3/8	3.03	73.5	81.0	1 3/8	3.33	79.0	87.1
1 1/2	3.60	88.5	96.0	1 1/2	3.96	95.1	103.0
1 5/8	4.23	103.0	113.0	1 5/8	4.65	111.0	122.0
1 3/4	4.90	119.0	130.0	1 3/4	5.39	128.0	140.0
1 7/8	5.63	138.0	152.0	1 7/8	6.19	148.0	163.0
2	6.40	154.0	169.0	2	7.04	166.0	182.0
2 1/4	8.10	193.0	210.0	2 1/4	8.91	208.0	226.0
2 1/2	10.00	235.0	260.0	2 1/2	11.00	253.0	280.0
2 3/4	12.10	280.0	305.0	2 3/4	13.30	301.0	328.0



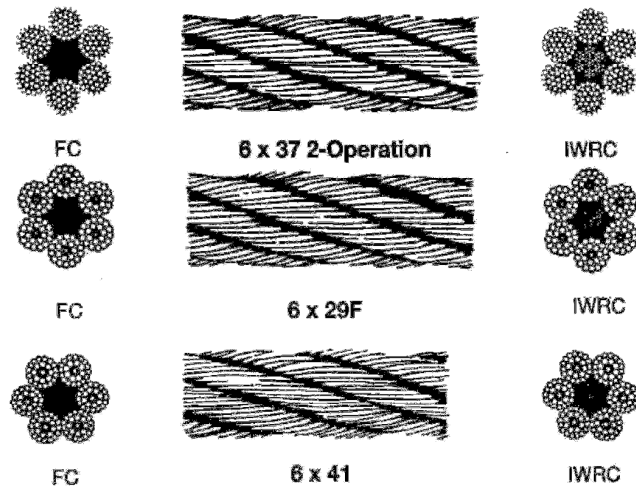

Figure 11-5. 6 x 37 classification of wire rope.

Table 11-3. Breaking strength of wire rope (6 x 37 classification).

Rope diameter (in.)	Weight (lb. per ft.)	Breaking strength in tons of 2,000 lb.		Rope diameter (in.)	Weight (lb. per ft.)	Breaking strength in tons of 2,000 lb.	
		Plow steel	Improved plow steel			Plow steel	Improved plow steel
1/4	0.10	2.2	2.5	1/4	0.11	2.4	2.7
5/16	0.16	3.8	4.0	5/16	0.18	4.1	4.3
3/8	0.22	5.0	5.5	3/8	0.24	5.4	5.9
7/16	0.30	6.9	7.5	7/16	0.33	7.4	8.1
1/2	0.39	9.2	10.0	1/2	0.43	9.9	10.8
9/16	0.49	11.4	12.5	9/16	0.54	12.3	13.4
5/8	0.61	14.5	16.0	5/8	0.67	15.6	17.2
3/4	0.87	20.2	22.2	3/4	0.96	21.7	23.9
7/8	1.19	27.5	30.2	7/8	1.30	29.6	32.5
1	1.55	36.0	39.5	1	1.1	38.7	42.5
1 1/8	1.96	44.0	49.0	1 1/8	2.16	47.3	52.7
1 1/4	2.42	55.0	61.0	1 1/4	2.66	59.1	65.6
1 3/8	2.93	68.5	74.5	1 3/8	3.22	73.6	80.1
1 1/2	3.49	82.0	90.0	1 1/2	3.84	88.1	96.7
1 5/8	4.09	96.5	105.5	1 5/8	4.50	104.0	113.0
1 3/4	4.75	110.0	121.0	1 3/4	5.23	118.0	130.0
1 7/8	5.45	129.0	142.0	1 7/8	6.00	139.0	153.0
2	6.20	142.0	155.0	2	6.82	153.0	167.0
2 1/4	7.85	182.0	201.0	2 1/4	8.64	196.0	216.0
2 1/2	9.69	225.0	245.0	2 1/2	10.66	242.0	263.0
2 3/4	11.72	269.0	293.0	2 3/4	12.89	289.0	315.0
3	13.95	323.0	353.0	3	15.35	347.0	379.0

## 11.3 SLINGS

### 11.3.1 GENERAL

- a. Slings shall have a minimum design factor appropriate to the type of material as specified in the appropriate section. Features that affect the rated capacity of the sling and that shall be considered in calculating the design factor are:
1. Nominal breaking strength of material from which it is constructed.
  2. Splicing or end-attachment.
  3. Number of parts in the sling.
  4. Type of hitch (e.g., straight pull, choker hitch, or basket hitch).
  5. Angle of loading and load center of gravity.
  6. Diameter of curvature around which the sling is bent.
- b. The center of gravity of an object is a point around which the entire weight may be concentrated. To make a level lift, the crane hook or point of suspension must be directly above this point. While slight variations are usually permissible, if the crane hook is too far to one side of the center of gravity, dangerous tilting will result and should be corrected at once. For this reason, when the center of gravity is closer to one point of the sling attachment than to the other, the slings must be of unequal length. Sling stresses and sling angles will also be unequal (see Figure 11-6).
- c. Rigging shall be configured such that slings do not reeve or slip through the hook. To attach the load, locate the center of gravity, position the crane hook directly above the center of gravity, and then rig the load so that it will lift level and true.

### 11.3.1.1 Load Angle Factor

- a. The following is an example of selecting a sling using the load angle factors shown in Figure 11-7.
1. Load = 1,000 lb.
  2. Sling = 2-legged bridle.
  3. Angle with horizontal = 45 degrees.
  4. Load angle factor from Figure 11-7 = 1.414
- b. Each of the two legs would lift 500 lb if a vertical lift were made. However, there is a 45 sling angle involved. Therefore, the 500-lb load would be multiplied by the load-angle factor in the chart, giving a total of 707 lb (500 lb x 1.414) tension in each sling leg. Each sling leg, therefore, must have a rated capacity of at least 707 lb.

### 11.3.1.2 Safe Load

- a. The rated capacity or working load limit (WLL) of a sling varies depending on the type of hitch. The rated capacity tables in this section show the applications for which the various safe loads apply when the slings are new. All ratings are in pounds (lbs).
- b. Figures 11-8 and 11-9 provide information for determining the total rated capacity of 3-leg slings so as not to introduce a working load in direct tension in any leg greater than that permitted. Two legs should be considered to carry the load because in normal lifting practice, the load will not be uniformly distributed on all legs. If rigging techniques, verified by a qualified rigger, ensure that the load is evenly distributed then full use of three legs is allowed. Special rigging techniques verified by a qualified engineer shall be required to prove that a load is evenly distributed over four or more sling legs.

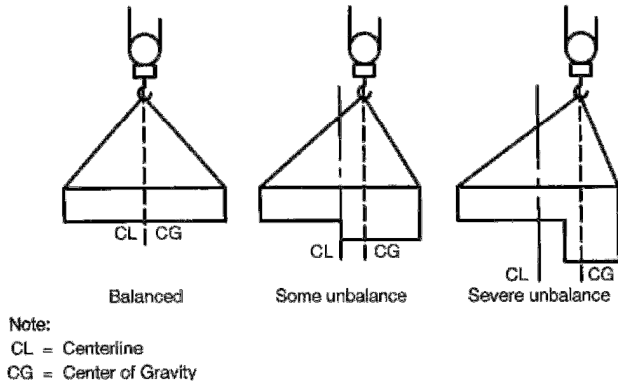

Figure 11-6. Balancing Loads

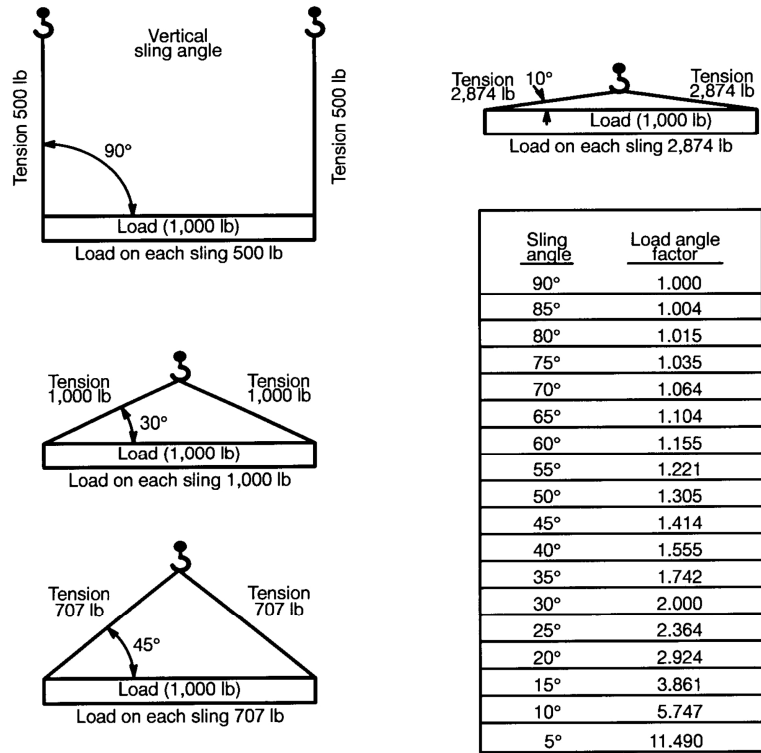

Figure 11-7. Relationship of load angle and lifting efficiency.

### 11.3.1.3 Design Factor

In general, a design factor of 5:1 is maintained throughout this section with the exception of alloy steel chain slings. Also, certain sling fittings, such as hooks (which will deform beyond usefulness before breaking) cannot be assigned a definite numerical design factor. In such cases, suitable safe loads are listed, based on wide experience and sound engineering practice.

### 11.3.1.4 Slings Care

Proper care and usage are essential for maximum service and safety. Wire-rope slings shall be protected from sharp bends and cutting edges by means of corner saddles, burlap padding, or wood blocking. Overloading shall be avoided, as shall sudden dynamic loading that can build up a momentary overload sufficient to break the sling.

### 11.3.1.5 Slings Storage

Personnel using slings shall ensure that they are stored properly as follows:

- a. Slings should be stored in racks (preferably vertical) and in designated locations when not in use. Do not store slings in a location where they will be subjected to mechanical damage, corrosive action, moisture, extreme heat, or kinking. Slings may require segregated storage as determined on a case-by-case basis.
- b. Before storage and periodically during storage, wipe slings clean to remove as much dirt and abrasive grit as possible and relubricate wire rope and chain slings to extend their useful life. Chains should not be lubricated when in use.
- c. Do not store metal-mesh slings in areas where the temperature exceeds 550 degrees F (288 degrees C) or 200 degrees F (93 degrees C) if elastomer covered.
- d. Do not store synthetic-web slings where the temperature exceeds 200 degrees F (93 degrees C).

### 11.3.1.6 Inspections

- a. Sling users shall visually inspect all slings each day they are used or prior to use if the sling has not been in regular service (records are not required). In addition, a periodic inspection shall be made at least annually by a qualified inspector. More frequent intervals for periodic inspections should be established if necessary as determined by a qualified person based upon:
  1. Frequency of sling use.
  2. Severity of service conditions.
  3. Nature of lifts being made.
  4. Experience gained on the service life of slings used in similar circumstances.
- b. Users shall carefully note any deterioration that could result in an appreciable loss of original strength and determine whether further use of the sling would constitute a safety hazard. Removal from service criteria are provided for each type of sling in their respective sections.

### 11.3.1.7 Slings Periodic Inspection Records

Individual site programs shall describe how inspections are recorded. These records may include an external coded mark on the individual sling tag (e.g. date, annually changed color stripe, etc.) indicating both periodicity and the satisfactory completion of the required inspection, or a written record as acceptable documentation.

## 11.3.2 WIRE-ROPE SLINGS

- a. In general, wire-rope slings are made up of 6 x 19 or 6 x 37 classification wire rope. Rotation-resistant wire rope shall not be used for wire-rope slings. Different kinds of slings have been developed for specific purposes. These are divided into different groups or types as follows:
  1. Endless-loop slings (grommet construction) and single-part slings with single-rope legs, double-rope legs, or multiple-part rope legs.

2. Two-leg bridle slings with single-rope legs, equalizing double-rope legs, or multiple-part tope legs.
  3. Three-leg bridle slings.
  4. Four-leg bridle slings.
  5. Special slings and combinations.
- b. The total load that can be safely lifted with slings depends on the rating of the slings and the manner in which they are attached to the load. Consult Tables 11-4 through 11-9 and Figure 11-10.
- c. Braided slings are made by braiding ordinary wire ropes together, thus making them more flexible than wire-rope slings. The size of a braided sling is determined by the diameter of one wire rope and the number of ropes in the cross section of the slings.
- d. The design factor for wire-rope slings shall be a minimum of 5:1 based upon breaking strength.
- e. When a wire rope sling is used in a choker hitch, the normal angle formed in the rope body as it passes through the choking eye is 120 degrees or greater [do not confuse the choke angle with the angle of inclination of the load (see Figure 11-10)]. Rated load in load capacity Tables 11-4 through 11-9 are for angles of 120 degrees or greater. For smaller angles, reduce the rated load to the percentages given in Figure 11-10.

When legs are not of equal length, use smallest H/L ratio

NOTE: Load may be supported on only 2 legs while 3rd leg balances it. Therefore, the required SWL is determined by the following:

Total Rated Capacity = WLL (of single vertical hitch) x H/L x 2

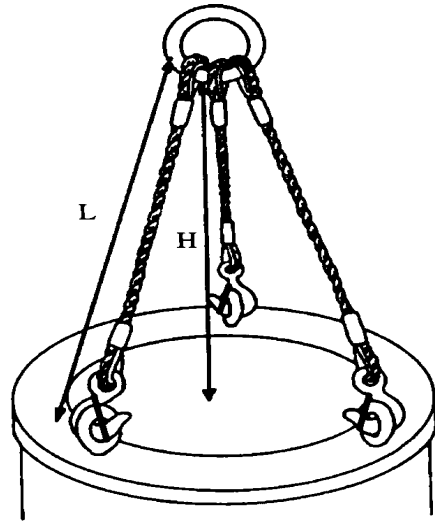

Figure 11-8. Determination of capacity – 3-leg bridle sling.

When legs are not of equal length, use smallest H/L ratio.

NOTE: Load may be carried by only 2 legs while other 2 legs balance it. Therefore, the required SWL is determined by the following:

Total Rated Capacity = WLL (of single vertical hitch) x H/L x 2

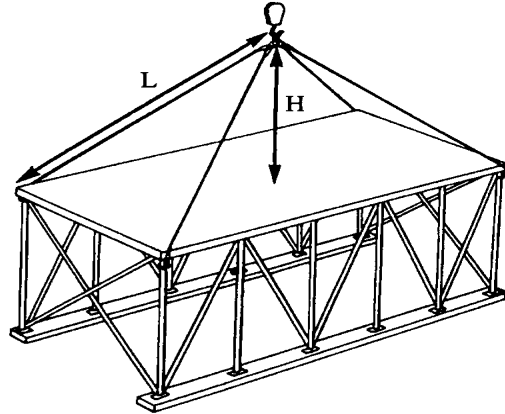



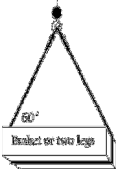



Figure 11-9. Determination of capacity – 4-leg bridle sling.

**Table 11-4. Load capacity of wire-rope slings.  
Hand tuck splice (IWRC) in pounds Design Factor = 5:1**

							
<b>Dia. in inches</b>	<b>Vertical</b>	<b>Choker</b>	<b>Basket or two legs</b>				<b>Dia. in inches</b>
1/4	1,100	820	2,200	1,800	1,500	1,100	1/4
5/16	1,600	1,280	3,200	2,800	2,200	1,600	5/16
3/8	2,400	1,840	4,800	4,000	3,200	2,400	3/8
7/16	3,000	2,400	6,000	5,400	4,400	3,000	7/16
1/2	4,000	3,200	8,000	6,800	5,600	4,000	1/2
9/16	5,000	4,000	10,000	8,600	7,000	5,000	9/16
5/8	6,000	5,000	12,000	10,400	8,400	6,000	5/8
3/4	8,400	7,200	16,800	14,600	11,800	8,400	3/4
7/8	11,000	9,600	22,000	19,200	15,600	11,000	7/8
1	14,000	12,600	28,000	24,000	20,000	14,000	1
1 1/8	18,000	15,800	36,000	32,000	26,000	18,000	1 1/8
*1 1/4	22,000	19,400	44,000	36,000	30,000	22,000	*1 1/4
*1 3/8	26,000	24,000	52,000	44,000	36,000	26,000	*1 3/8
*1 1/2	32,000	28,000	64,000	52,000	42,000	32,000	*1 1/2
*1 5/8	36,000	32,000	72,000	62,000	50,000	36,000	*1 5/8
*1 3/4	42,000	38,000	84,000	70,000	58,000	42,000	*1 3/4
*2	56,000	48,000	112,000	92,000	74,000	56,000	*2
Wire Rope/6 x 19 and *6 x 37 IPS IWRC							

## Notes:





- (1) These values only apply when the D/d ratio is 25 or greater (choker and basket hitches)

D = Diameter of curvature around which the body of the sling is bent

d = Diameter of rope

- (2) Choker hitch values apply only to choke angles greater than 120 degrees.

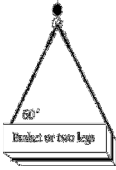
**Table 11-5. Load capacity of wire-rope slings.  
Hand tuck splice (Fiber Core) in pounds Design Factor = 5:1**

							
<b>Dia. in inches</b>	<b>Vertical</b>	<b>Choker</b>	<b>Basket or two legs</b>				<b>Dia. in inches</b>
1/4	980	760	1,960	1,700	1,400	980	1/4
5/16	1,500	1,200	3,040	2,600	2,200	1,500	5/16
3/8	2,200	1,700	4,400	3,600	3,000	2,200	3/8
7/16	2,800	2,400	5,600	5,000	4,000	2,800	7/16
1/2	3,600	3,000	7,200	6,400	5,200	3,600	1/2
9/16	4,600	3,800	9,200	8,000	6,400	4,600	9/16
5/8	5,600	4,600	11,200	9,600	8,000	5,600	5/8
3/4	7,800	6,600	15,600	13,600	11,000	7,800	3/4
7/8	10,400	9,000	20,080	17,800	14,600	10,400	7/8
1	13,400	11,800	26,800	22,000	18,800	13,400	1
1 1/8	16,800	14,800	33,600	28,000	24,000	16,800	1 1/8
*1 1/4	20,000	18,000	40,000	34,000	28,000	20,000	*1 1/4
*1 3/8	24,000	22,000	48,000	42,000	34,000	24,000	*1 3/8
*1 1/2	30,000	26,000	60,000	52,000	42,000	30,000	*1 1/2
*1 5/8	34,000	30,000	68,000	58,000	48,000	34,000	*1 5/8
*1 3/4	40,000	34,000	80,000	70,000	56,000	40,000	*1 3/4
*2	52,000	44,000	104,000	90,000	74,000	52,000	*2
Wire Rope/6 x 19 and *6 x 37 IPS FC							

## Notes:

- (1) These values only apply when the D/d ratio is 25 or greater (choker and basket hitches)





D = Diameter of curvature around which the body of the sling is bent

d = Diameter of rope

- (2) Choker hitch values apply only to choke angles greater than 120 degrees.

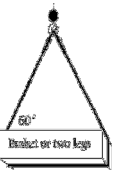
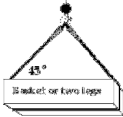

**Table 11-6. Load capacity of wire-rope slings.  
Mechanical splice (IWRC) in pounds Design Factor = 5:1**

							
<b>Dia. in inches</b>	<b>Vertical</b>	<b>Choker</b>	<b>Basket or two legs</b>				<b>Dia. in inches</b>
1/4	1,100	840	2,200	1,940	1,580	1,100	1/4
5/16	1,700	1,300	3,400	3,000	2,400	1,700	5/16
3/8	2,400	1,860	4,800	4,200	3,600	2,400	3/8
7/16	3,400	2,500	3,800	5,800	4,800	3,400	7/16
1/2	4,400	3,200	8,800	7,600	6,200	4,400	1/2
9/16	5,500	4,200	11,000	9,600	7,700	5,500	9/16
5/8	6,800	5,000	13,600	11,800	9,600	6,800	5/8
3/4	9,700	7,200	19,400	16,800	13,600	9,700	3/4
7/8	13,000	9,800	26,000	22,000	18,300	13,000	7/8
1	17,000	12,800	34,000	30,000	24,000	17,000	1
1 1/8	20,000	15,600	40,000	36,000	30,000	20,000	1 1/8
*1 1/4	25,000	18,400	50,000	42,000	34,000	25,000	*1 1/4
*1 3/8	30,000	24,000	60,000	52,000	42,000	30,000	*1 3/8
*1 1/2	36,000	28,000	72,000	64,000	50,000	32,000	*1 1/2
*1 5/8	42,000	32,000	84,000	70,000	58,000	42,000	*1 5/8
*1 3/4	50,000	38,000	100,000	82,000	66,000	50,000	*1 3/4
*2	64,000	48,000	128,000	106,000	86,000	64,000	*2

## Notes:





- (1) These values only apply when the D/d ratio is 25 or greater (choker and basket hitches)

D = Diameter of curvature around which the body of the sling is bent

d = Diameter of rope

- (2) Choker hitch values apply only to choke angles greater than 120 degrees.

**Table 11-7. Load capacity of wire-rope slings.  
8-part braided rope in pounds Design Factor = 5:1**

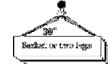
						
<b>Dia. in inches</b>	<b>Vertical</b>	<b>Choker</b>	<b>Basket or two legs</b>			<b>Dia. in inches</b>
*1/8	1,900	1,400	3,200	2,600	1,900	*1/8
*3/16	4,200	3,000	7,200	5,800	4,200	*3/16
3/16	3,400	2,600	6,000	4,800	3,400	3/16
1/4	6,200	4,600	10,600	8,600	6,200	1/4
5/16	9,600	7,200	16,600	13,400	9,600	5/16
3/8	13,600	10,200	24,000	19,400	13,600	3/8
7/16	18,000	13,800	32,000	26,000	18,600	7/16
1/2	24,000	18,000	42,000	34,000	24,000	1/2
9/16	30,000	22,000	52,000	42,000	30,000	9/16
5/8	38,000	28,000	64,000	52,000	38,000	5/8
3/4	54,000	40,000	92,000	76,000	54,000	3/4
7/8	72,000	54,000	124,000	102,000	72,000	7/8
1	94,000	70,000	162,000	132,000	94,000	1
Wire Rope/6 x 19 IPS and *7 x 7 Galvanized Aircraft Grade						

## Notes:







- (1) These values only apply when the D/d ratio is 25 or greater (choker and basket hitches)

D = Diameter of curvature around which the body of the sling is bent

d = Diameter of rope

- (2) Choker hitch values apply only to choke angles greater than 120 degrees.

**Table 11-8. Load capacity of wire-rope slings.  
Cable laid grommet-hand tucked in pounds Design Factor = 5:1**

Dia. in inches	 Vertical	 Choker	 Basket or two legs	 60 degrees	 45 degrees	 30 degrees	Dia. in inches
*3/8	2,600	1,900	5,000	4,400	3,600	2,600	*3/8
*9/16	5,600	4,200	11,200	9,800	8,000	5,600	*9/16
*5/8	7,800	6,000	15,800	13,600	11,200	6,800	*5/8
3/4	10,200	7,600	20,000	17,600	14,400	10,200	3/4
15/16	15,800	11,800	32,000	28,000	22,000	15,800	15/16
1 1/8	22,000	16,800	44,000	38,000	32,000	22,000	1 1/8
1 5/16	30,000	22,000	60,000	52,000	42,000	30,000	1 5/16
1 1/2	38,000	28,000	78,000	66,000	54,000	38,000	1 1/2
1 11/16	48,000	36,000	98,000	84,000	68,000	48,000	1 11/16
1 7/8	60,000	44,000	120,000	104,000	84,000	60,000	1 7/8
2 1/4	84,000	62,000	168,000	146,000	118,000	84,000	2 1/4
2 5/8	112,000	84,000	224,000	194,000	158,000	112,000	2 5/8
3	144,000	108,000	286,000	248,000	202,000	144,000	3
Wire Rope/*7 x 6 x 7 and 7 x 6 x 19 IPS IWRC							

## Notes:







- (1) These values only apply when the D/d ratio is 10 or greater (choker and basket hitches)

D = Diameter of curvature around which the body of the sling is bent

d = Diameter of rope

- (2) Choker hitch values apply only to choke angles greater than 120 degrees.

**Table 11-9. Load capacity of wire-rope slings.  
Strand laid grommet-hand tucked in pounds Design Factor = 5:1**

							
<b>Dia. in inches</b>	<b>Vertical</b>	<b>Choker</b>	<b>Basket or two legs</b>	<b>60 degrees</b>	<b>45 degrees</b>	<b>30 degrees</b>	<b>Dia. in inches</b>
1/4	1,840	1,320	3,600	3,200	2,600	1,840	1/4
3/8	4,000	3,000	8,000	7,000	5,800	4,000	3/8
1/2	7,000	5,200	14,000	12,200	10,000	7,000	1/2
5/8	10,800	8,000	22,000	18,800	15,200	10,800	5/8
3/4	15,200	11,400	30,000	26,000	22,000	15,200	3/4
7/8	20,000	15,200	40,000	34,000	28,000	20,000	7/8

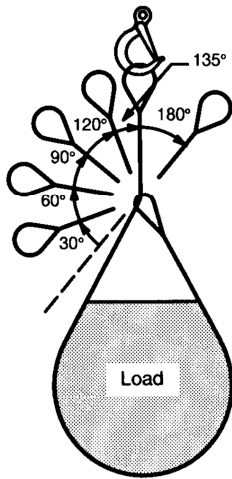

Angle of choke in degrees	Rated capacity IWRC and FC rope percent **
Over 120	100
90-120	87
60-89	74
30-59	62
0-29	49

\*\*Percent of sling rated capacity in a choker hitch

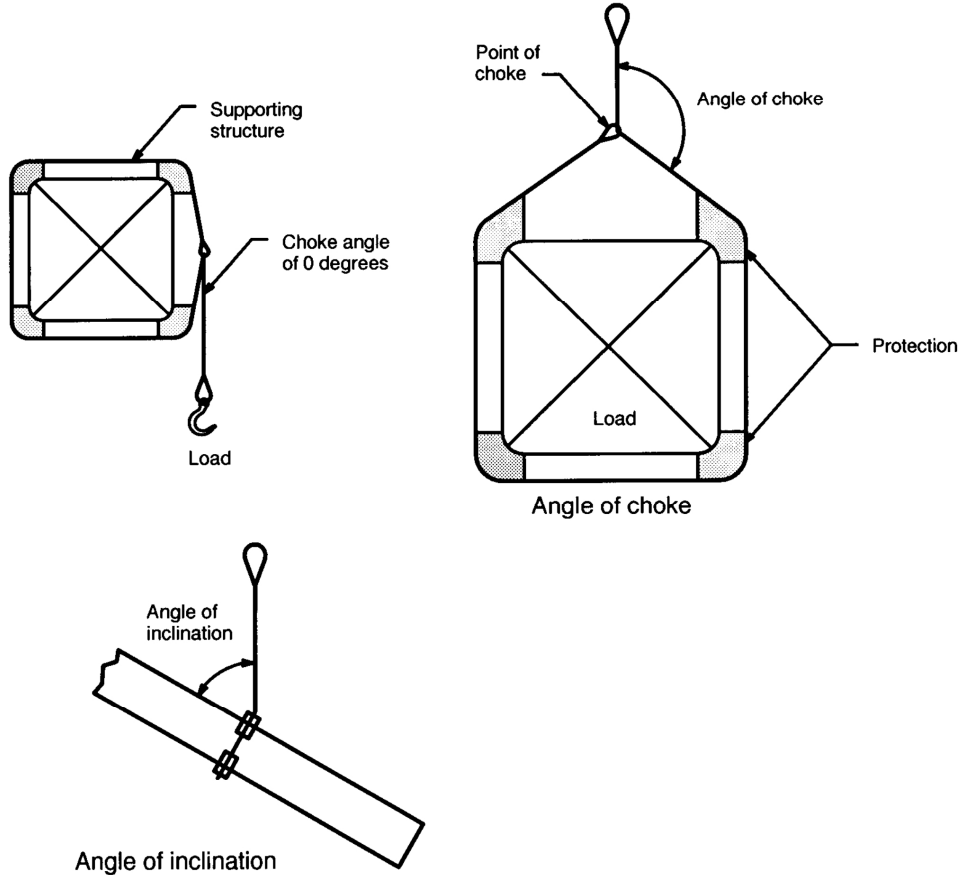

Reprinted from ASME B30.9-2006 by permission of The American Society of Mechanical Engineers. All rights reserved.

Figure 11-10. Choker hitch rated capacity adjustment.

**11.3.2.1 Removal from Service Criteria**

- a. Wire rope slings shall be immediately removed from service if any of the following conditions are present:
1. Missing or illegible sling identification
  2. Broken wires
    - i. For strand-laid and single-part slings, ten randomly distributed broken wires in one rope lay, or five broken wires in one strand in one rope lay.
    - ii. For cable-laid slings, 20 broken wires per lay.
    - iii. For six-part braided slings, 20 broken wires per braid.
    - iv. For eight-part braided slings, 40 broken wires per braid
  3. Severe localized abrasion or scraping
  4. Kinking, crushing, birdcaging, or any other damage resulting in damage to the rope structure
  5. Evidence of heat damage
  6. End attachments that are cracked, deformed, or worn to the extent that the strength of the sling is substantially affected
  7. Severe corrosion of the rope, end attachments, or fittings
  8. For hooks, removal criteria as stated in Section 12.2.
  9. Other conditions, including visible damage, that cause doubt as to the continued use of the sling

**11.3.2.2 Proof-Testing**

- a. All swaged socket and poured socket sling assemblies shall be proof-tested to the wire

rope or fitting manufacturer's recommendations but in no case greater than 50 percent of the component wire rope's or structural strand's nominal strength. All other sling assemblies shall be proof-tested when specified by the purchaser.

- b. As a minimum, the proof load shall be equal to the rated capacity but shall not exceed:
1. 125 percent of the vertical rated capacity for single-let, hand-tucked slings.
  2. 200 percent of the vertical rated capacity for mechanical-splice single-leg slings and endless slings.
- c. The proof-load for multiple-leg bridle slings assemblies shall be applied to the individual leg and shall be in accordance with paragraph a. and b. as applicable.
- d. Master links to which multiple-leg slings are connected shall be proof-loaded to 200 percent times the force applied by the combined legs.
- e. Welded end attachments shall not be used unless proof-tested at 2 times rated capacity prior to initial use.
- f. Test loads described above shall be accurate to within -5 percent, +0 percent of stipulated values. A written letter of certification by the manufacturer or a pull test witnessed and certified in writing by a qualified person is acceptable.

**11.3.2.3 Operation**

- a. The following shall apply to all personnel who use wire-rope slings:
1. Start and stop slowly; sudden starts and stops dramatically increase the stresses in hoist ropes and slings. Lift slowly until the load is suspended to minimize swinging.

**DOE-STD-1090-2007**

2. Loads shall be set on blocks. Do not pull a sling from under a load that is resting on the sling.
3. Ensure that wire-rope slings are protected against weather, chemicals, solvents, and high temperatures.
4. Permanently remove from service fiber-core rope slings that have been exposed to temperatures in excess of 180 degrees F (82 degrees C).
5. When wire rope slings of any grade are to be used at temperatures above 400 degrees F (204 degrees C) or below -60 degrees F (-51 degrees C), the sling manufacturer should be consulted.
6. Extremely low temperatures (less than 0 degrees F) may cause brittle fractures. Under these conditions, sudden loading should be avoided and the rope should be carefully observed while the load is being applied.
7. Do not use knotted slings.
8. Do not use single-let wire-rope slings unless proper precautions are taken to prevent suspended loads from rotating.
9. Rigging shall be configured such that slings do not reeve or slip through the hook.
10. Do not make a complete turn of wire rope around the crane hook.
11. Use protector pads or blocking at sharp corners.
12. Keep hands and fingers out of the area between the sling and the load.
13. Ensure that the weight of the load is within the rated capacity of the sling.
14. Do not use damaged slings.
15. Ensure that all personnel stand clear of the suspended load.
16. Avoid shock loading.
17. In a basket hitch, ensure that the load is balanced to prevent slippage.
18. Avoid handling hot material with wire-rope slings.
19. Use shackles or adjustable choker hooks when making choker hitches.
20. Store slings on racks away from moisture and acids when not in use.
21. Ensure that damaged wire-rope slings are rendered unusable, removed from service, discarded, and replaced with new slings.
22. Before use and before storage, check wire-rope slings for:
  - i. Broken or cut wires or strands.
  - ii. Rust or corrosion.
  - iii. Kinks.
  - iv. Broken seizing wire.
  - v. Damage to swaged fittings.
  - vi. Other signs of damage or abuse.
23. The capacity of wire-rope slings is derated by the manufacturer by applying the efficiency factors such as those given in Figure 11-11.
24. Do not use wire-rope clips to fabricate wire-rope slings except where the application of slings prevents the use of prefabricated slings and where the specific application is designed by a qualified person. Fabrication of wire rope slings for construction applications is also prohibited (See Section 15.4.2). Slings made with wire rope clips should not be used as a choker hitch (see Figures 11-12 and 11-13).

DOE-STD-1090-2007

- |  |   |
|--|---|
| <p>25. If wire-rope clips are used to fabricate slings, the capacity of the sling shall be derated in accordance with the clip manufacturer's recommendations. Manufacturer's recommendations shall also be followed with regard to clip spacing, number of clips, and torque values.</p> <p>26. Wire rope clips used to fabricate wire rope slings shall be of drop-forged steel. Malleable cast iron clips shall not be used.</p> <p>27. Wire rope clips attached with U-bolts shall have the U-bolt over the dead end of the rope and the live rope resting in the clip saddle. Clips shall be tightened evenly to the recommended torque. After the initial load is applied to the rope, the clip nuts shall be retightened to the recommended torque to compensate for any decrease in rope diameter caused by the load. Rope clip nuts should be retightened periodically to compensate for any further decrease in rope diameter during usage.</p> <p>28. At a minimum, wire-rope slings shall be marked with the following information:</p> <ul style="list-style-type: none"><li>i. Name of trademark of manufacturer</li></ul> | <ul style="list-style-type: none"><li>ii. Rated capacity for the type of hitch(es)</li><li>iii. Diameter or size</li></ul> <p>29. Sling identification shall be maintained by the user so as to be legible during the life of the sling.</p> <p>30. Slings made of rope with 6 x 19 and 6 x 37 construction and cable-laid slings shall have a minimum clear length of rope 10 times the rope diameter between splices, sleeves, or end fittings.</p> <p>31. Braided slings shall have a minimum clear length of rope 40 times the component (individual) rope diameter between the loops or end fittings.</p> <p>32. Grommets and endless slings shall have a minimum circumferential length of 96 times the body diameter of the grommet or endless sling.</p> <p>33. Other configurations may be used provided a qualified engineer provides a documented evaluation, including a destructive pull test in the configuration to be used, as well as use limitations. Minimum design factor of 5:1 shall be maintained.</p> |
|--|---|



Efficiencies of wire rope fittings or fastenings  
in percentages of strength of rope:

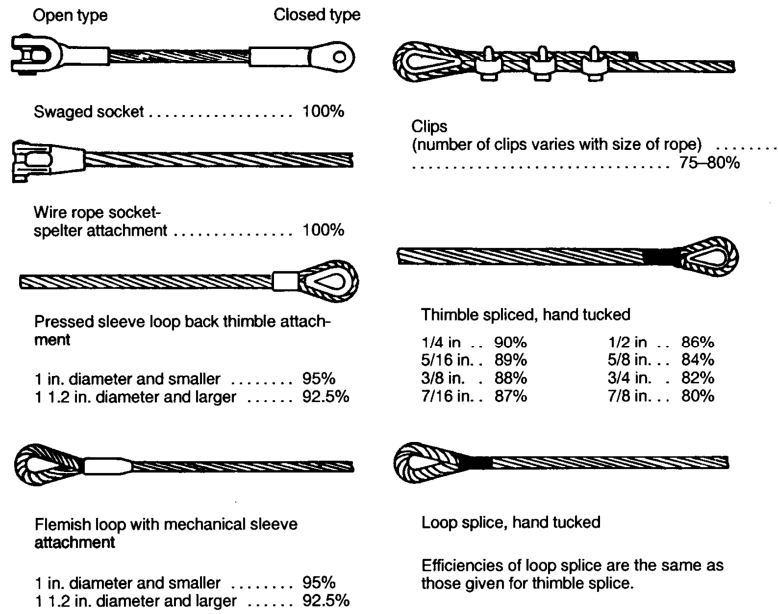
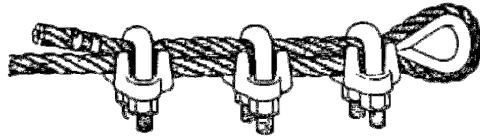
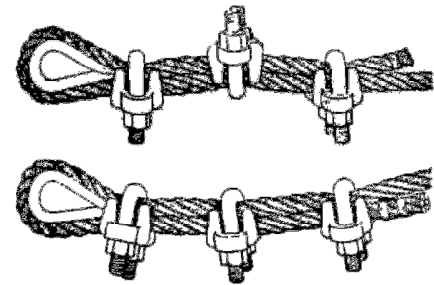

Figure 11-11. Wire-rope fastenings.



Note that the base of the clip bears against the live end of the wire rope, while the “U” of the bolt presses against the dead end.

Figure 11-12. Wire-rope clips – right Way.



The “U” of the clips shall not bear against the live end of the wire rope because of the possibility of the rope being kinked or crushed.

Figure 11-13. Wire-rope clips – wrong way.

**11.3.2.4 Critical Lifts**

See chapter 2, "Critical Lifts," for critical lift requirements.

1. All provisions of paragraph 11.3.2.3.a also shall apply to critical lifts.
2. Wire-rope slings used for critical-lift service shall have an initial proof test. If proof testing cannot be verified, the wire-rope sling(s) shall be proof tested before being used to make a critical lift. As a minimum, the proof load shall be equal to the rated capacity, but shall not exceed:
  - i. The wire rope or fitting manufacturers' recommendations, but in no case greater than 50 percent of the component wire rope's or structural strands' nominal strength, for all swaged socket and poured socket sling assemblies.
  - ii. 125 percent of the vertical rated capacity of single-leg, hand-tucked slings.
  - iii. 200 percent of the vertical rated capacity for mechanical-spliced single-let slings and endless slings.
  - iv. The proof-load for multiple-leg bridle slings assemblies shall be applied to the individual leg and shall be in accordance with paragraph I, ii, and iii, as applicable.
  - v. Master links to which multiple-leg slings are connected shall be proof-loaded to 200 percent times the force applied by the combined legs.
  - vi. Test weights shall be accurate to within  $-5$  percent,  $+0$  percent of stipulated values.
3. Wire-rope sling eyes with thimbles shall be made with a thimble having a ratio of thimble diameter (D) to rope diameter (d) of 3 or more (D/d greater than or equal 3).
  4. Do not use wedge sockets or wire-rope clips on slings used for critical lifts.
  5. Ensure that working loads of wire-rope slings do not exceed their rated capacities.
  6. Do not splice slings together.
  7. Use thimble eyes for slings to be joined end-to-end.
  8. Locate sling eyes so that:
    - i. Adequate clearance is maintained between the attached slings and other parts or surfaces of the component or equipment.
    - ii. There is no interference with the functioning of hoisting, rigging, or handling equipment.
    - iii. Maximum accessibility to the eye is maintained.
    - iv. Attached slings can converge over the center of gravity of the lift.
    - v. Proper stability can be maintained during lifting and positioning of the item at the installation site.
    - vi. The plane of the slinging eye is coincident with the plane of the sling under loaded conditions within  $\pm 5$  degrees.
    - vii. Sling angles are not less than 45 degrees with the horizontal.
  9. In addition to marking requirements listed for ordinary lifts, other items may need to be marked as determined on a case-by-case basis, such as the reach, type, weight of the sling assembly, and rated capacity.

### 11.3.3 ALLOY STEEL-CHAIN SLINGS

- a. This section applies to slings made from grade 80 and 100 alloy chain manufactured and tested in accordance with National Association of Chain Manufacturers welded steel chain specifications – 1990. If chain other than this is used, it shall be used in accordance with the recommendations of the chain manufacturer.
- b. Alloy Steel-chain slings differ from wire-rope slings in that components using wire are replaced by link chain. Other sling components are similar. Chain slings are more rugged and flexible, but less shock resistant than wire-rope or braided slings. This size is measured by the link stock.
- c. Two basic types with many variations are used: basket type and hook type. An example of each is shown in Figure 11-14.

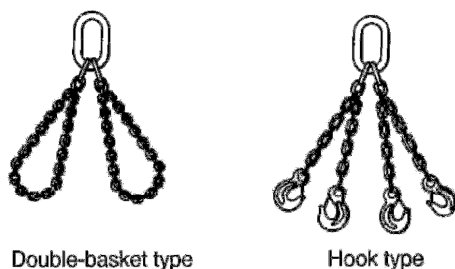

**Figure 11-14. Types of chain slings.**

- d. Alloy-steel-chain slings shall not be heated above 1,000 degrees F (537 degrees C) after being received from the manufacturer.
- e. When exposed to service temperatures in excess of 600 degrees F (315 degrees C), reduce working load limits in accordance with the chain manufacturer's recommendations.
- f. Extremely low temperatures (less than 0 degrees F) may cause brittle fractures. Under these conditions, sudden loading should be avoided and the load should be lifted a very short distance while the chains are carefully inspected.
- g. The design factor for steel-chain slings shall be a minimum of 4:1 based upon breaking strength.
- h. Chains should be stored in racks or in designated locations when not in use. Chains should never be stored in damp or dirty places, nor in places exposed to the weather. For long-term storage, they should receive a coating of oil. The ends of all empty chains should be hooked onto the hoist hook or bull ring.
- i. Chains should not be lubricated when in use because this might make them dangerous to handle. Chains should be cleaned periodically to remove abrasive grit and to facilitate inspection.
- j. The total load that can be lifted safely with steel-chain slings depends on the manner by which the slings are attached to the load. If all legs of a steel-chain sling are hooked back into the master link, the safe-load capacity of the whole sling may be increased by 100 percent if the capacity of the master link is not exceeded.
- k. The safe-load level of any chain sling is a function of three basic factors: size and number of legs, condition of chain and other components, and sling angle between legs and horizontal. Table 11-10 shows safe loads in pounds per leg which can be carried by various chain-sling arrangements. Note the effect of very low hook height and wide leg spreads.
- l. Hooks, rings, oblong links, pear shaped links, welded or mechanical coupling links and other attachments shall have a rated capacity at least equal to that of the alloy steel chain with which they are used or the sling shall not be used in excess of the rated capacity of the weakest component.

#### 11.3.3.1 Removal from Service Criteria





- a. Missing or illegible sling identification.
- b. Cracks or breaks.

- c. Excessive wear, nicks, or gouges. Minimum thickness on chain links shall not be below the values listed in Table 11-11.
- d. Stretched chain links or components.
- e. Bent, twisted, or deformed chain links or components.
- f. Evidence of heat damage.
- g. Excessive pitting or corrosion.
- h. Lack of ability of chain or components to hinge (articulate) freely.
- i. Weld splatter.
- j. For hooks, removal criteria as stated in Chapter 12.
- k. Other conditions, including visible damage, that cause doubt as to the continued use of the sling.

#### 11.3.3.2 Proof-Testing

- a. Single-leg and endless alloy-steel chain slings shall be certified as having been proof-tested to 200 percent of the rated capacity prior to initial use.
- b. The proof load for multiple-let bridle slings shall be applied to the individual legs and shall be 200 percent of the vertical rated capacity of a single-leg sling.
- c. Master links to which multiple-leg slings are connected shall be proof-loaded to 200 percent multiplied by the force applied by the combined legs.
- d. Test loads shall be accurate to within -5 percent, +0 percent of stipulated values. Either certification by the manufacturer or a pull test certified by a qualified person is acceptable.

Table 11-10. Rated load for Grade 80 Alloy Steel Chain Slings

Size in inches	 Single Leg	 60° Two Legs	 45° Two Legs	 30° Two Legs
9/32	3,500	6,100	4,900	3,500
3/8	7,100	12,300	10,000	7,100
1/2	12,000	20,800	17,000	12,000
5/8	18,100	31,300	25,600	18,100
3/4	28,300	49,000	40,000	28,300
7/8	34,200	59,200	48,400	34,200
1	47,700	82,600	67,400	47,700
1 1/4	72,300	125,200	102,200	72,500

Reprinted from ASME B30.9-2006 by permission of The American Society of Mechanical Engineers. All rights reserved.

Notes:

- (1) Other grades of proof tested steel chain include Proof Coil (grade 28), Hi-Test (Grade 43) chain and Transport (Grade 70) chain. These grades are not recommended for overhead lifting and therefore are not covered in the applicable standards.
- (2) Rating of multi-leg slings adjusted for angle of loading between the inclined leg and the horizontal plane of the load.

**Table 11-11. Minimum allowable thickness at any point on a link**

Nominal Chain or Coupling Link Size		Minimum Allowable Thickness at Any Point on the Link	
in.	mm	in.	mm
$\frac{7}{32}$	5.5	0.189	4.80
$\frac{9}{32}$	7	0.239	6.07
$\frac{5}{16}$	8	0.273	6.93
$\frac{3}{8}$	10	0.342	8.69
$\frac{1}{2}$	13	0.443	11.26
$\frac{5}{8}$	16	0.546	13.87
$\frac{3}{4}$	20	0.687	17.45
$\frac{7}{8}$	22	0.750	19.05
1	26	0.887	22.53
$1\frac{1}{4}$	32	1.091	27.71

Reprinted from ASME B30.9-2006 by permission of The American Society of Mechanical Engineers. All rights reserved.

### 11.3.3.3 Operation

- a. The following shall apply to all personnel who use steel-chain slings:
1. Do not set a load on a sling or pull a sling from under a load. Place wooden blocks or other supports under the load to provide sufficient clearance for the chain.
  2. Shorten chain slings by hooking back into the chain, into the master link, or with grab hooks. Do not shorten by knotting, twisting, bolting, or inserting the tip of the hook into a link.
  3. Do not hammer a chain to force it into position.
  4. Protect chain slings from sharp corners that might bend the links. Use a suitable pad to prevent gouging or bending of the chain links, as well as possible scarring of the load.
  5. When making choker hitches with chain slings, always face the hook opening out and away from the pull of the sling so that the hooks will not slip out when slack is taken out of the sling.

6. Do not weld or perform local repairs on chain slings. All defective chain slings should be returned, through a formal procedure, to the manufacturer for examination, repair, and recertification.
7. Avoid sudden loading of chain slings.
8. Maintain latches on hooks in good condition.
9. If a chain sling does not look safe, do not use it. Do not assume that a chain sling is safe because it looks new; look for stretched links. If in doubt, check with the supervisor.
10. Do not carry loads on the point or tip of a hook.
11. Avoid unbalanced loads.
12. Do not use homemade links, makeshift fasteners formed from bolts, rods, and the like, or other nonstandard attachments.
13. Do not use makeshift or field-fabricated hooks on steel-chain slings.
14. Hook the ends of all empty chain onto the hoist hook or bull ring.
15. Each steel-chain sling shall be marked, at a minimum, with:
  - i. Nominal Chain Size
  - ii. Grade
  - iii. Rated load for the type(s) of hitch(es) used and the angle on which the rating is based
  - iv. Length (Reach)
  - v. Number of legs.
  - vi. Name or trademark of manufacturer

- 16. Where slings have more than one leg, ensure that the tag is affixed to the master link.
- 17. Ensure that the working load does not exceed the rated capacity of the sling.

- b. The carbon steel used in metal-mesh slings shall be processed to produce the required mechanical properties.
- c. The material used for stainless-steel metal-mesh slings shall conform, at least, to the American Iron and Steel Institute standards for Type-302 or Type-304 stainless steel. Other materials may be used. When metal-mesh slings are produced from such materials, however, the sling manufacturer should be consulted for specific data.
- d. The handle shall be designed to ensure:
  - 1. At least the same rated capacity as the fabric.
  - 2. No visible permanent deformation after proof-testing.
- e. The fabric and handles shall be so joined that:
  - 1. The rated capacity of the sling is not reduced.
  - 2. The load is evenly distributed across the width of the fabric.
  - 3. Sharp edges do not damage the fabric.
- f. Metal-mesh slings may be painted, plated, impregnated with elastomers such as neoprene or polyvinyl chloride (PVC), or otherwise suitably coated. The coating shall not diminish the rated capacity of a sling.
- g. The design factor for metal-mesh slings shall be a minimum of 5:1 based upon breaking strength.
- h. Metal-mesh slings shall not be used to lift loads greater than the rated capacity, properly derated for other than straight-pull configurations (Table 11-13.).
- i. Except for elastomer-impregnated slings, all metal-mesh slings covered by this section may be used without derating in a temperature range from -20 degrees F (-29 degrees C) to 550 degrees F (288 degrees C).

**11.3.3.4 Critical Lifts**

See Chapter 2, “Critical Lifts,” for critical lift requirements.

- a. Single-leg and endless alloy-steel chain slings used for critical-lift service shall have an initial proof test of 200 percent of the vertical rated capacity. If proof testing cannot be verified, the sling(s) shall be proof tested before being used to make a critical lift.
- b. The proof load for multiple-leg bridle slings shall be applied to the individual legs and shall be 200 percent of the vertical rated capacity of a single-leg sling.
- c. Master links to which multiple-leg slings are connected shall be proof-loaded to 200 percent multiplied by the force applied by the combined legs.

**11.3.4 METAL-MESH SLINGS**

- a. Metal-mesh slings (Figure 11-15) shall be classified with the designations shown in Table 11-12, based on types of duty and material classification.

**Table 11-12. Metal-mesh sling Designations.**

Type Designation	Classification	
Heavy duty	Carbon steel	35-CS
	Stainless steel	35-SS
Medium duty	Carbon steel	43-CS
	Stainless steel	43-SS
Light duty	Carbon steel	59-CS
	Stainless steel	59-SS

- j. All metal-mesh slings covered by this section and impregnated with PVC or neoprene shall be used only in a temperature range from 0 degrees F (-18 degrees C) to 200 degrees F (93 degrees C).
- k. For operation at temperatures outside these ranges or for other impregnations, consult the manufacturer for specific data.

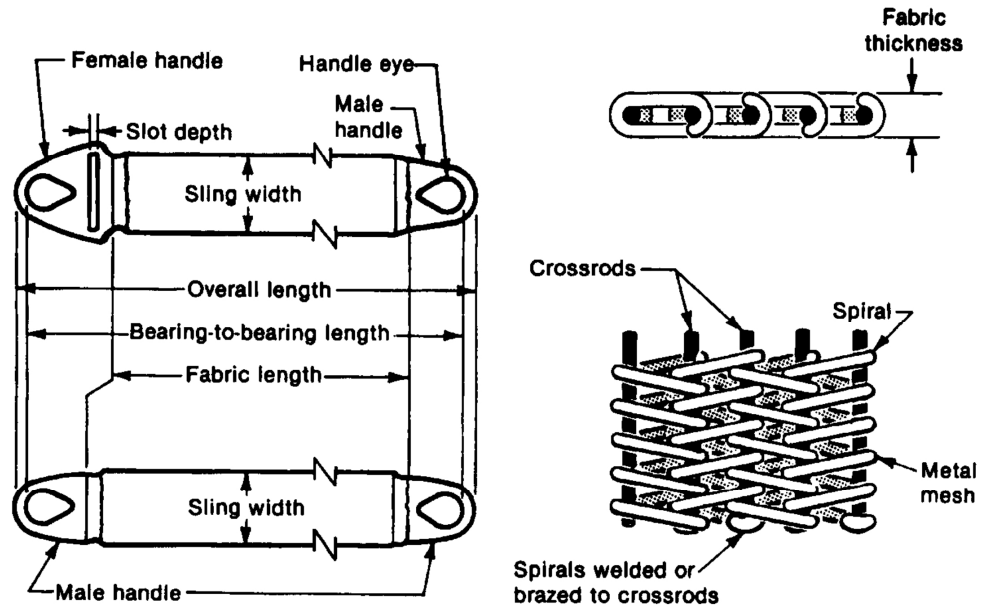







Figure 11-15. Typical metal-mesh sling.

Reprinted from ASME B30.9-2006 by permission of The American Society of Mechanical Engineers. All rights reserved.



**Table 11-13. Load capacity of carbon and stainless-steel metal-mesh slings in pounds.  
Design Factor = 5:1**

						
Sling width (in.)	Vertical or choker	Basket or two legs	60° Basket or two legs	45° Basket or two legs	30° Basket or two legs	Sling width (in.)
Heavy duty 10-ga 35 spirals/ft of mesh width						
2	1,500	3,000	2,600	2,100	1,500	2
3	2,700	5,400	4,700	3,800	2,700	3
4	4,000	8,000	6,900	5,600	4,000	4
6	6,000	12,000	10,400	8,400	6,000	6
8	8,000	16,000	13,800	11,300	8,000	8
10	10,000	20,000	17,000	14,100	10,000	10
12	12,000	24,000	20,700	16,900	12,000	12
14	14,000	28,000	24,200	19,700	14,000	14
16	16,000	32,000	27,700	22,600	16,000	16
Medium duty 12-ga 43 spirals/ft of mesh width						
2	1,350	2,700	2,300	1,900	1,400	2
3	2,000	4,000	3,500	2,800	2,000	3
4	2,700	5,400	4,700	3,800	2,700	4
6	4,500	9,000	7,800	6,400	4,500	6
8	6,000	12,000	10,400	8,500	6,000	8
10	7,500	15,000	13,000	10,600	7,500	10
12	9,000	18,000	15,600	12,700	9,000	12
14	10,500	21,000	18,200	14,800	10,500	14
16	12,000	24,000	20,800	17,000	12,000	16
Light duty 14-ga 59 spirals/ft of mesh width						
2	900	1,800	1,600	1,300	900	2
3	1,400	2,800	2,400	2,000	1,400	3
4	2,000	4,000	3,500	2,800	2,000	4
6	3,000	6,000	5,200	4,200	3,000	6
8	4,000	8,000	6,900	5,700	4,000	8
10	5,000	10,000	8,600	7,100	5,000	10
12	6,000	12,000	10,400	8,500	6,000	12
14	7,000	14,000	12,100	9,900	7,000	14
16	8,000	16,000	13,900	11,300	8,000	16

**11.3.4.1 Removal from Service Criteria**

Metal-mesh slings shall be removed from service if any of the following defects are present:

- a. Missing or illegible sling identification
- b. Broken weld or a broken brazed joint along the sling edge
- c. Broken wire in any part of the mesh.
- d. Reduction in wire diameter of 25% due to abrasion or 15% due to corrosion.
- e. Lack of flexibility due to distortion of the mesh
- f. Distortion of the choker fitting so the depth of the slot is increased by more than 10%.
- g. Distortion of either end fitting so the width of the eye opening is decreased by more than 10%.
- h. A 15% reduction of the original cross-sectional area of any point around the hook opening of the end fitting.
- i. Visible distortion of either end fitting out of its plane.
- j. Cracked end fitting.
- k. Slings in which the spirals are locked or without free articulation shall not be used.
- l. Fittings that are pitted, corroded, cracked, bent, twisted, gouged, or broken.
- m. Other conditions, including visible damage, that cause doubt as to the continued use of the sling.

**11.3.4.2 Proof-Testing**

- a. Metal-mesh slings shall be certified as having been proof-tested to 200 percent of their rated capacity prior to initial use.

- b. Coated slings shall be proof-tested prior to being coated.
- c. Test loads shall be accurate to within -5 percent, +0 percent of stipulated values. Either certification by the manufacturer or a pull test certified by a qualified person is acceptable.

**11.3.4.3 Operation**

- a. The following shall apply to all personnel who use metal-mesh slings:
  1. Ensure that the weight of the load is within the rated capacity of the sling.
  2. Ensure that metal-mesh slings have suitable characteristics and rated capacity for the load and environment.
- b. Metal-mesh slings should be long enough to provide the maximum practical angle between the sling leg and the horizontal (minimum practical angle at the crane hook if vertical angles are used).
- c. Do not shorten metal-mesh slings with knots, bolts, or other unapproved methods.
- d. Do not use damaged slings.
- e. Securely hitch metal-mesh slings to the load.
- f. Ensure that sharp corners are padded.
- g. Keep hands and fingers out of the area between the sling and the load.
- h. Ensure that all personnel stand clear of the suspended load.
- i. Avoid shock loading.
- j. Do not pull metal-mesh slings from under a load when the load is resting on the sling.
- k. Do not store metal-mesh slings in an area where they will be subjected to mechanical damage or corrosive action.

- l. Avoid twisting and kinking of the legs.
- m. In a choker hitch, ensure that metal-mesh slings are long enough so that the female handle chokes freely on the mesh, never on the handle.
- n. In a choker hitch, ensure that the load is balanced. When this cannot be done, consult the manufacturer for a derating factor or for other means of handling this type of load.
- o. In a basket hitch, ensure that the load is balanced to prevent slippage.
- p. Do not use metal-mesh slings in which the spirals are locked or are without free articulation.
- q. Never hammer a sling to straighten a spiral or cross rod or to force a spiral into position.
- r. Metal-mesh slings used in pairs should be attached to a spreader beam.
- s. Ensure that all metal-mesh slings have a permanently affixed metal identification tag or tags containing the following information:
  - 1. Manufacturer's name or trademark.
  - 2. Rated load for the type(s) of hitch(es) used and the angle upon which it is based.
  - 3. Width and gauge.

shall be 200 percent of the vertical rated capacity of a single-leg sling.

- c. Master links to which multiple-leg slings are connected shall be proof-loaded to 200 percent multiplied by the force applied by the combined legs.

### 11.3.5 SYNTHETIC-WEB SLINGS

- a. Synthetic web shall possess the following qualities:
  - 1. Be of sufficient strength to meet the sling manufacturer's requirements.
  - 2. Have uniform thickness and width.
  - 3. Have selvage edges and not be split from its woven width.
- b. The thread used in the manufacture of a synthetic-web sling shall be of the same type of material as the web.
- c. Fittings shall be:
  - 1. Of sufficient strength to sustain twice the rated capacity without permanent deformation.
  - 2. Of a minimum breaking strength equal to that of the sling.
  - 3. Free of all sharp edges that would in any way damage the webbing.
- d. The stitching in all load-bearing splices shall be of sufficient strength to maintain the sling design factor.
- e. Synthetic-web slings may be coated with elastomers, anti-fungicides, UV inhibitors or other treatments that will provide improved characteristics such as abrasion resistance, sealing of pores, increased coefficient of friction, and UV resistance.
- f. The design factor for synthetic-web slings shall be a minimum of 5:1 based upon breaking strength.

#### 11.3.4.4 Critical Lifts

See Chapter 2, "Critical Lifts," for critical lift requirements.

- a. Metal-mesh slings used for critical-lift service shall have an initial proof test of 200 percent of the vertical rated capacity. If proof testing cannot be verified, the sling(s) shall be proof tested before being used to make a critical lift.
- b. The proof load for multiple-leg bridle slings shall be applied to the individual legs and

- g. Rated capacities are affected by the type of hitch used and by the angle from the vertical when used as multi-legged slings or in basket hitches. The sling manufacturer shall supply data on these effects.
- h. Synthetic-web slings are available in a number of configurations as follows (see Figure 11-17):
1. *Endless or Grommet Sling* – Both ends of one piece of webbing are lapped and sewn to form a continuous piece. They can be used as vertical hitches, bridle hitches, in choker arrangements, or as basket slings.
  2. *Standard Eye and Eye* – Webbing is assembled and sewn to form a flat eye sling with an eye at each end and the eye openings in the same plane as the sling body. The eyes may either be full web width or may be tapered by being folded and sewn to a width narrower than the webbing width.
  3. *Twisted Eye* – An eye-and-eye type that has twisted terminations at both ends. The eye openings are at 90 degrees to the plane of the sling body. This configuration is also available with either full-width or tapered eyes.
  4. *Metal End Fittings* - In place of the sewn eyes, synthetic-web slings are also available with metal end fittings (see Figure 11-19). The most common are triangle and choker hardware. Combination hardware consists of a triangle for one end of the sling and a triangle/rectangle choker attachment for the other end. With this arrangement, both choker and basket hitches, as well as straight hitches, may be rigged. They help reduce wear in the sling eyes and thus lengthen sling life.
- i. Synthetic-web slings can be cut by repeated use around sharp-cornered objects. They eventually show signs of abrasion when they are repeatedly used to hoist rough-surfaced products. There are, however, protective devices offered by most sling manufacturers that minimize these effects (see Figure 11-20). Other protective devices include:
1. Buffer strips of leather, nylon, or other materials that are sewn on the body of a sling protect against wear. While offering some resistance to wear and cutting, leather is subject to weathering and gradual deterioration. Leather is not recommended in lengths over 6 ft due to the different stretching characteristics of the leather and webbing. On the other hand, nylon-web wear pads are more resistant to weathering, oils, grease, and most alkalis; and they stretch in the same ratio as the sling body.
  2. Edge guards consist of strips of webbing or leather sewn around each edge of the sling. This is necessary for certain applications where the sling edges are subject to damage.
  3. Sleeve- or sliding-tube-type wear pads are available for slings used to handle material having sharp edges. They can be positioned on the sling where required, do not move when the sling stretches, adjust to the load, and cover both sides of the sling.
  4. Eye buffers can be attached at the bearing point of the sling eye. This attachment increases the longevity of the fabric sling.
  5. Coatings can be applied to provide added resistance to abrasion and chemical damage. These treatments also increase the coefficient of friction, affording a better grip when loads with slippery surfaces are to be handled.
- j. The synthetic-web sling capacities listed in Tables 11-14 and 11-15 are approximations only and are based on nylon or polyester webbing having breaking strengths between 6,800 and 9,800 lb/in. of webbing width. The capacities are also based on a 5:1 design factor and assume that the end fittings are of adequate strength.

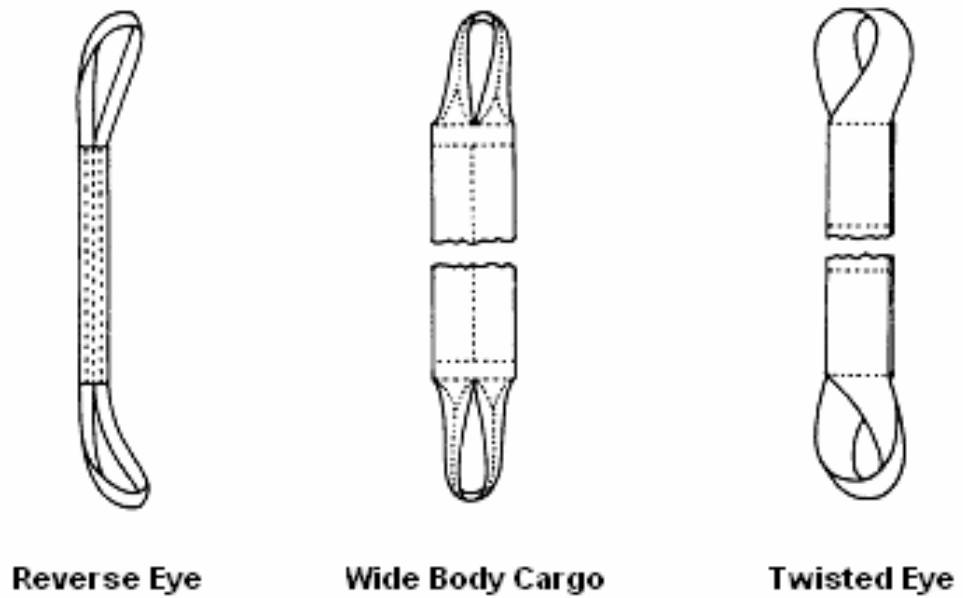
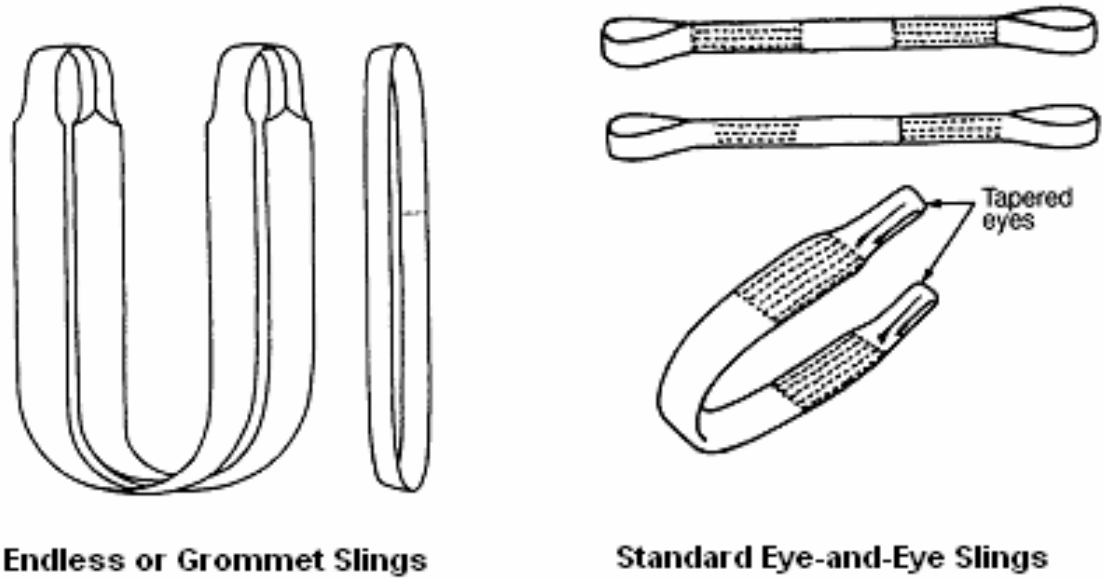
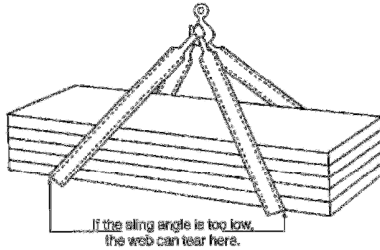

Figure 11-17. Synthetic-web sling types.

- k. Although safe working loads for bridle hitches in the choker or double-basket configuration are provided, they should be used only with extreme caution because, as the sling angle decreases, one edge of the web will take all the load, producing a risk of tearing (see Figure 11-18).



**Figure 11-18. Effect of low sling angle.**

- l. Synthetic-web slings shall be used in accordance with the sling manufacturer's recommendation.
- m. Conventional three-strand natural or synthetic fiber rope slings are NOT recommended for lifting service, and should be used only if conventional sling types are not suitable for a unique application. The requirements of ASME B 30.9 ("Slings"), Section 9-4, and 29 CFR 1910.184(h) shall be followed.
- n. Tiedown and/or ratchet strap shall not be used as synthetic-web slings. Only synthetic-web slings constructed from webbing approved for sling construction by the manufacturer or other qualified person shall be used at DOE locations.

#### 11.3.5.1 Removal from Service Criteria

Slings shall be immediately removed from service if any of the following defects are visible:

- a. Acid or caustic burns.

- b. Melting or charring of any part of the surface.
- c. Snags, punctures, tears, or cuts.
- d. Broken or worn stitching in load bearing splices.
- e. Excessive abrasive wear.
- f. Knots in any part of the sling.
- g. Excessive pitting or corrosion, or cracked, distorted, or broken fittings.
- h. Discoloration, brittle or stiff areas on any part of the sling that may indicate chemical or UV damage.
- i. Other visible damage that causes doubt as to the strength of the sling.
- j. Missing or illegible sling identification.

#### 11.3.5.2 Proof-Testing

- a. For single or multiple leg slings and endless slings, each leg shall be proof loaded to 2 times the single-leg vertical hitch rated load.
- b. The proof load for fittings attached to single legs shall be a minimum of 2 times the single-leg vertical hitch rated load.
- c. Master links for two leg bridle slings shall be proof loaded to a minimum of 4 times the single leg vertical hitch rated load.
- d. Master links for three leg bridle slings shall be proof loaded to a minimum of 6 times the single leg vertical hitch rated load.
- e. Master links for four leg bridle slings shall be proof loaded to a minimum of 8 times the single leg vertical hitch rated load.

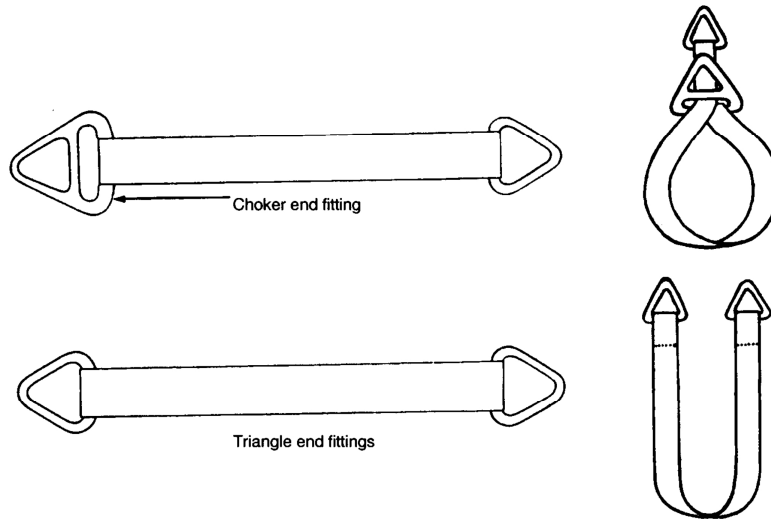
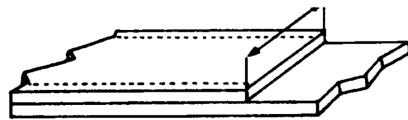

Figure 11-19. Examples of Metal End Fittings



**REGULAR.** This is the type of edge protection that is sewn on to give fixed protection at expected wear points. They can be sewn anywhere on the sling, at any length on one side, or on both sides.





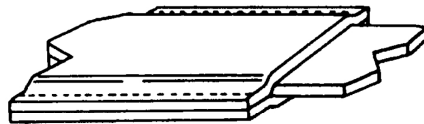



**EDGE GUARD.** A strip of webbing or leather is sewn around each edge of the sling. This is necessary for certain applications where the sling edges are subject to damage.

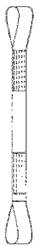

**SLEEVE.** Sometimes called sleeve or sliding-tube type wear pads, these pads are ideal for handling material with sharp edges because the sleeve does not move when the sling stretches and adjusts to the load. Sleeves cover both sides of the sling and can be shifted to points of expected maximum wear.

Figure 11-20. Examples of Web and edge protectors

**Table 11-14. Typical load capacity of Class 5 synthetic web slings in pounds.  
Design Factor 5:1  
(Regular eye and eye, twisted eye, triangle fittings, choker fittings)**







Web width (in.)	 Vertical	 Choker	 Basket or two legs	 60° Basket or two legs	 45° Basket or two legs	 30° Basket or two legs	Web width (in.)
Single Ply Web Slings (6,800 lb/in. material)							
1	1,100	880	2,200	1,900	1,600	1,100	1
2	2,200	1,760	4,400	3,800	3,100	2,200	2
3	3,300	2,640	6,600	5,700	4,700	3,300	3
4	4,400	3,520	8,800	7,600	6,200	4,400	4
5	5,500	4,400	11,000	9,500	7,800	5,500	5
6	6,600	5,280	13,200	11,400	9,300	6,600	6
Double Ply Web slings (6,800 lb/in. material)							
1	2,200	1,760	4,400	3,800	3,100	2,200	1
2	4,400	3,520	8,800	7,620	6,200	4,400	2
3	6,600	5,280	13,200	11,400	9,300	6,600	3
4	8,200	6,560	16,400	14,200	11,600	8,200	4
5	10,200	8,160	20,400	17,700	14,400	10,200	5
6	12,300	9,840	24,600	21,300	17,400	12,300	6

Reprinted from ASME B30.9-2006 by permission of The American Society of Mechanical Engineers. All rights reserved.

- (1) For an endless sling with vertical hitch carrying a load of such size as to throw the legs more than 5 degrees off vertical, use rated load data for regular eye and eye sling, basket hitch and corresponding leg angles.
- (2) Follow manufacturer's capacities, they vary from manufacturer to manufacturer and from this chart.
- (3) Choker hitch values apply only to choke angles greater than 120 degrees.



**Table 11-15. Typical load capacity of Class 7 synthetic web slings in pounds.  
Design Factor 5:1  
(Regular eye, twisted eye, triangle fittings, choker fittings)**

Web width (in.)	 Vertical	 Choker	 Basket or two legs	 60° Basket or two legs	 45° Basket or two legs	 30° Basket or two legs	Web width (in.)
Single Ply Web Slings (9,800 lb/in. material)							
1	1,600	1,280	3,200	2,800	2,300	1,600	1
2	3,100	2,480	6,200	5,400	4,400	3,100	2
3	4,700	3,760	9,400	8,100	6,600	4,700	3
4	6,200	4,960	12,400	10,700	8,800	6,200	4
5	7,800	6,240	15,600	13,500	11,000	7,800	5
6	9,300	7,440	18,600	16,100	13,200	9,300	6
Double Ply Web slings (9,800 lb/in. material)							
1	3,100	2,480	6,200	5,400	4,400	3,100	1
2	6,200	4,960	12,400	10,700	8,800	6,200	2
3	8,800	7,040	17,600	15,200	12,400	8,800	3
4	11,000	8,800	22,000	19,100	15,600	11,000	4
5	13,700	10,960	27,400	23,700	19,400	13,700	5
6	16,500	13,200	33,000	28,600	23,000	16,500	6

Reprinted from ASME B30.9-2006 by permission of The American Society of Mechanical Engineers. All rights reserved.

- (1) For an endless sling with vertical hitch carrying a load of such size as to throw the legs more than 5 degrees off vertical, use rated load data for regular eye and eye sling, basket hitch and corresponding leg angles.
- (2) Follow manufacturer's capacities, they vary from manufacturer to manufacturer and from this chart.
- (3) Choker hitch values apply only to choke angles greater than 120 degrees.

**11.3.5.3 Operation**

The following shall apply to all personnel who use synthetic-web slings:

- a. Determine the weight of the load and center of gravity.
- b. Select a sling having suitable characteristics for the type of load, hitch, and environment.
- c. Ensure that slings with end fittings that are used in a choker hitch have sufficient length to that the choking action is on the body of the sling.
- d. In slings used in a basket hitch, balance the load to prevent slippage.
- e. Do not drag slings across the floor or over any abrasive surface.
- f. Do not twist or tie slings into knots.
- g. Protect slings from being cut by sharp corners, sharp edges, and highly abrasive surfaces.
- h. Do not pull slings from under loads when a load is resting on a sling.
- i. Do not use synthetic-web slings to lift loads in excess of the rated capacity. Properly derate for other than straight-pull configuration.
- j. Store synthetic-web slings to prevent mechanical or chemical damage.
- k. Do not use nylon slings where acid conditions exist.
- l. Do not use polyester and polypropylene slings where caustic conditions exist.
- m. Nylon and polyester slings shall not be used on contact with objects or at temperatures in excess of 194 degree F (90 degree C), or below -40 degree F (-40 degree C). Polypropylene slings shall not be used in contact with objects or at temperatures in

excess of 150 degree F (66 degree C), or below -40 degree F (-40 degree C). The sling manufacturer should be consulted for the temperature range of slings made from other synthetic yarns.

- n. Do not use aluminum fittings where acid or caustic fumes, vapors, sprays, mists or liquids are present.
- o. Ensure that each sling is permanently marked to show:
  1. Name or trademark of manufacturer.
  2. Manufacturer's code or stock number.
  3. Rated capacity for types of hitches used.
  4. Type of synthetic-web material.
- p. Synthetic web slings (e.g., Kevlar, K-Spec, nylon, polyester) may be used in radiation areas only when a qualified person ensures that the absorbed dose does not exceed 100,000 rad during the life of the sling.

**11.3.5.4 Critical Lifts**

See Chapter 2, "Critical Lifts," for critical lift requirements.

- a. Synthetic-web slings used for critical-lift service shall have an initial proof test of 200 percent of the vertical rated capacity. If proof testing cannot be verified, the sling(s) shall be proof tested before being used to make a critical lift.
- b. Proof testing shall be performed in accordance with Section 11.3.5.2, Proof-Testing.

**11.3.6 SYNTHETIC ROUNDSLINGS**

- a. Synthetic roundslings shall possess the following qualities:
  1. Core yarn shall be of a synthetic fiber wound together on a plurality of turns for even distribution of the load.

2. In general, the cover and core should be of the same type of material. However, in chemically active environments, the cover and core shall be of the same type of material.
  3. When the core and cover are the same yarn type, the thread should be of the same yarn type. When the cover and the core are of different yarn type, the thread should be of the same material as the core.
  4. Finishes and coatings shall be compatible with material of the core, cover, and thread and not impair the performance of the roundsling.
- b. Fittings shall be:
1. Of sufficient strength to sustain twice the rated capacity without permanent deformation.
  2. Of a minimum breaking strength equal to that of the roundsling.
  3. Free of all sharp edges that would in any way damage the roundsling.
  4. Compatible with the mechanical and environmental requirements imposed on the roundsling.
- c. The roundsling manufacturer should be consulted before roundslings are used in chemically active environments.
- d. Polyester slings shall not be used on contact with objects or at temperatures in excess of 194 degree F (90 degree C), or below -40 degree F (-40 degree C). Polypropylene slings shall not be used in contact with objects or at temperatures in excess of 150 degree F (66 degree C), or below -40 degree F (-40 degree C). The sling manufacturer should be consulted for the temperature range of slings made from other synthetic yarns.
- e. The design factor for synthetic roundslings shall be a minimum of 5:1 based on breaking strength.
  - f. Rated capacities are affected by the type of hitch used and by the angle from the vertical when used as multi-legged slings or in basket hitches. The sling manufacturer shall supply data on these effects.
  - g. Synthetic roundslings can be cut by repeated use around sharp-cornered objects. They eventually show signs of abrasion when they are repeatedly used to hoist rough-surfaced products. There are, however, protective devices offered by most sling manufacturers that minimize these effects.
  - h. The roundsling capacities listed in Table 11-16 are approximate only. The capacities are also based on a 5:1 design factor, and assume that the end fittings are of adequate strength.

**11.3.6.1 Removal from Service Criteria**

Synthetic roundslings shall be removed from service if any of the following defects are visible:

- a. Missing or illegible sling identification.
- b. Acid or caustic burns.
- c. Evidence of heat damage.
- d. Holes, tears, cuts, abrasive wear, or snags that expose the core yarns.
- e. Broken or damaged core yarns.
- f. Weld splatter that exposes core yarns.
- g. Roundslings that are knotted.
- h. Discoloration and brittle or stiff areas on any part of the sling, which may mean chemical or UV damage.
- i. Fittings that are pitted, corroded, cracked, bent, twisted, gouged or broken
- j. Hooks whose condition meets the removal criteria of Section 12.2.

- k. Other conditions, including visible damage, that may cause doubt as to the continued use of the sling.

### 11.3.6.2 Proof-Testing

- a. When specified by the purchaser, synthetic round slings of all types shall be certified as having been proof-tested prior to initial use.
  1. For single or multiple leg slings and endless slings, each leg shall be proof loaded to 2 times the single-leg vertical hitch rated load.
  2. The proof load for fittings attached to single legs shall be a minimum of 2 times the single-leg vertical hitch rated load.
  3. Master links for two leg bridle slings shall be proof loaded to a minimum of 4 times the single leg vertical hitch rated load.
  4. Master links for three leg bridle slings shall be proof loaded to a minimum of 6 times the single leg vertical hitch rated load.
  5. Master links for four leg bridle slings shall be proof loaded to a minimum of 8 times the single leg vertical hitch rated load.
- b. Test loads shall be accurate to within -5 percent, +0 percent of stipulated values. Either certification by the manufacturer or a pull test certified by a qualified person is acceptable.

### 11.3.6.3 Operation

The following shall apply to all personnel who use roundslings:

- a. Determine the weight and center of gravity of the load.
- b. Select a sling having suitable characteristics for the type of lad, hitch, and environment.

- c. Ensure that slings with end fittings that are used in a choker hitch have sufficient length so that the choking action is on the body of the sling.
- d. In slings used in a basket hitch, balance the load to prevent slippage.
- e. Do not drag slings across the floor or over any abrasive surface.
- f. Do not twist or tie slings into knots.
- g. Protect slings from being cut by sharp corners, sharp edges, and highly abrasive surfaces.
- h. Do not pull slings from under loads when a load is resting on a sling.
- i. Do not use roundslings to lift loads in excess of the rated capacity, properly derated for other than straight-pull configuration.
- j. When not in use, store slings to prevent mechanical, chemical or environmental damage.
- k. Personnel should never stand in line with or next to a roundslings that is under tension.
- l. If extreme temperatures are involved, ensure the guidance in 11.3.6.d is followed.
- m. Do not allow the load, hook, or any fitting to constrict, bunch, or pinch roundslings.
- n. Ensure that roundslings are not used as bridles on suspended personnel platforms.
- o. For multiple leg roundslings used with non-symmetrical loads, an analysis should be performed by a qualified person to prevent overloading of any leg.
- p. Ensure that each sling is permanently marked to show:
  1. Name or trademark of manufacturer.
  2. Manufacturer's code or stock number.





- 3. Rated loads for the type(s) of hitch(es) used and the angle upon which it is based.
- 4. Core material
- 5. Cover material, if different than core material.
- q. Synthetic roundslings (e.g., Kevlar, K-Spec, nylon, polyester) may be used in radiation areas only when a qualified person ensures that the absorbed dose does not exceed 100,000 rad during the life of the sling.

#### 11.3.6.4 Critical Lifts

See Chapter 2, "Critical Lifts," for critical lift requirements.

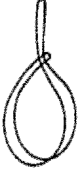
- a. Synthetic roundslings used for critical-lift service shall have an initial proof test of 200 percent of the vertical rated capacity. If proof testing cannot be verified, the sling(s) shall be proof tested before being used to make a critical lift.
- b. Proof testing shall be performed in accordance with Section 11.3.6.2, Proof-Testing.

**Table 11-16 - Load capacity of Single Leg Polyester Roundslings in pounds.  
Endless and Eye-and-Eye Type, Design Factor 5:1**

Size (Note 1)	 Vertical	 Choker	 Basket or two leg	 60 degrees	 45 degrees	 30 degrees
1	2,600	2,100	5,200	4,500	3,700	2,600
3/82	5,300	4,200	10,600	9,300	7,500	5,300
1/23	6,400	6,700	16,800	14,500	11,900	6,400
5/84	10,600	8,500	21,200	18,400	15,000	10,600
3/45	13,200	10,600	26,400	22,900	18,700	13,200
7/86	16,800	13,400	33,600	29,100	23,800	16,800
7	21,200	17,000	42,400	36,700	30,000	21,200
8	25,000	20,000	50,000	43,300	35,400	25,000
9	31,000	24,800	62,000	53,700	43,800	31,000
10	40,000	32,000	80,000	69,300	56,600	40,000
11	53,000	42,400	106,000	91,800	74,900	53,000
12	66,000	52,800	132,000	114,300	93,300	66,000
13	90,000	72,000	180,000	155,900	127,300	90,000

Reprinted from ASME B30.9-2006 by permission of The American Society of Mechanical Engineers. All rights reserved.

**NOTES:**

1. Roundslings are identified by the vertical rated load shown on the tag. The Size Number in this column has been adopted by the Web Sling and Tiedown Association to describe certain polyester roundslings. They are included for reference only. Other polyester roundslings may have different vertical rated loads.
2. Color guidelines for polyester roundsling covers are widely used to indicate the vertical rated load of roundslings; however, this is not followed by some manufacturers. Always select and use roundslings by the rated load as shown on the tag, never by color.