

# The Characters





Politecnico  
di Torino

# *Project book*

## *Material: Product components*

A.Y. 2022/2023

Professor. F.Valpreda, F. Alessio, S.Mauro, F.A.

Deorsola, G.L. Beccaria,

The characters: E.Bernocco, M. Di Lorenzo, G.

Ghione, E. Ilbay, A. Proposito



# ***Index***

## **1.0 Introduction**

*1.1 History of the Luxo lamp*

*1.2 Study luxo*

## **2.0 Study Concept**

*2.1 connection with the Luxo lamp*

*2.2 scenario*

*2.3 concept*

*2.4 case studies*

*2.5 guidelines of our lamp*

*2.6 personas*

*2.7 journey maps*

## **3.0 Project**

*3.1 needs, requirement and performance of the lamp*

*3.2 general and essential schemes*

*3.3 sketches*

*3.4 lamp kit: 3 bases and configurations*

*3.5 ergonomic studies*

*3.6 joint studies and functions*

*3.7 material of the lamp*

*3.8 logo design*

## **4.0 Light studies**

*4.1 light features*

*4.2 light parameters*

*4.3 case studies of light scattering*

*4.4 light beam adjustment system and dimension*

## **5.0 Final design**

*5.1 final renders*

*5.2 technical drawings*

## **6.0 Prototype**

*6.1 process development and prototype photos*

## **7.0 Sharing**

*7.1 open design methodology*

*7.2 open source within the course*

*7.3 workshop*

*7.4 next step*

*7.5 licence of use*

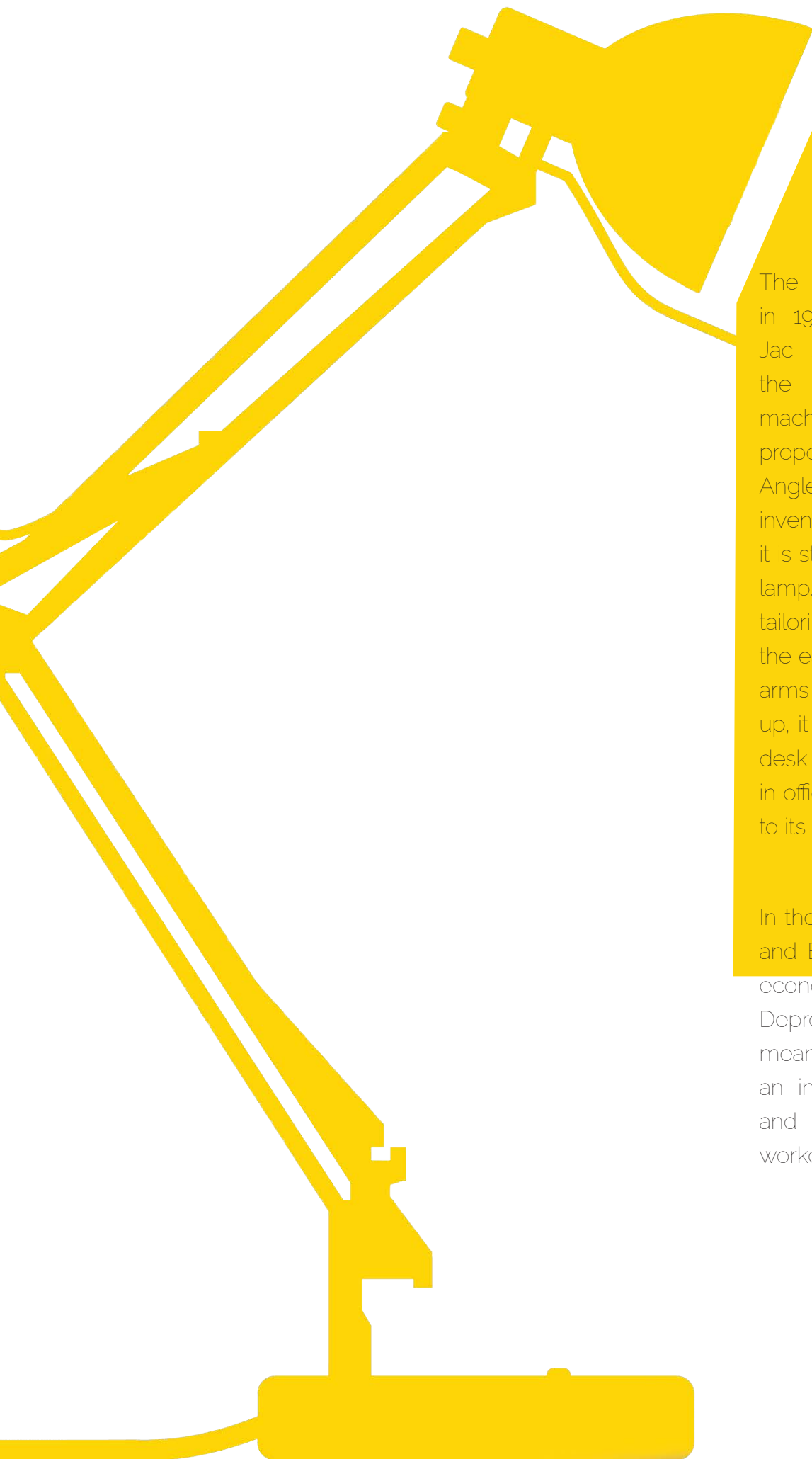

The Luxo lamp was born in 1937 from the mind of Jac Jacobsen, Founder of the homonymous textile machinery company. Initially proposed as a variant of the Anglepoise, a desk lamp invented a few years earlier, it is still used today as a desk lamp. Originally meant for tailoring work, because of the ease of movement of the arms while the machinist got up, it was also used for other desk works, finding wide use in offices and factories thanks to its price.

In the late 30s, both America and Europe were recovering economically from the Great Depression. This recovery meant, among other things, an increase in employment and greater attention to workers welfare.

At that time, design continued to be influenced by Fordism and industrial production, where particular attention was paid to materials and new technologies. The predominant style was functional minimalism, which can be summarized in the phrase "form follows function". At the same time in Norway (Jacobsen's native country) as in other Scandinavian countries, Scandinavian design was experiencing a period of great recognition. Its philosophy was based on the absolute consideration of the functionality and practicality of the object, favouring the essentiality of the form and sometimes, contact with the nature. The Luxo fits into this context, and from that it began to be known in Europe and North America, and produced mostly in Norway, Sweden and California. From a technical point of view, its functional system is very effective and userfriendly. The shape of the double-articulated quadrilateral arms allows a wide range of movements. Up-down and forward-backward movement without

modifying the position of the reflector which always moves parallel to itself. Furthermore, adequate solidity is guaranteed to support the entire structure without running the risk of overturning the lamp. Originally, it was created with a flat base surface that could be removed and screwed into a clamp attachment (again for desk based tasks, especially for architects). After some time, a floor base was developed, which meant that the lamp could be used to illuminate a larger area. In the years the Luxo has been re-designed in various ways ranging from chromatic variations to structural improvements. In 1986, it was chosen as the protagonist of a Pixar short film, which with its project demonstrated the strong narrative impact that can be created with a computer. To this day, the Luxo is still remembered as the Pixar lamp, which made it an iconic lamp that is still one of the most influential in the history of design.

# History of the Luxo lamp

At first glance, the Luxo lamp, appears simple, but in reality it is actually a lot of parts. Some of these parts can be disassembled easily, others are difficult and complex.

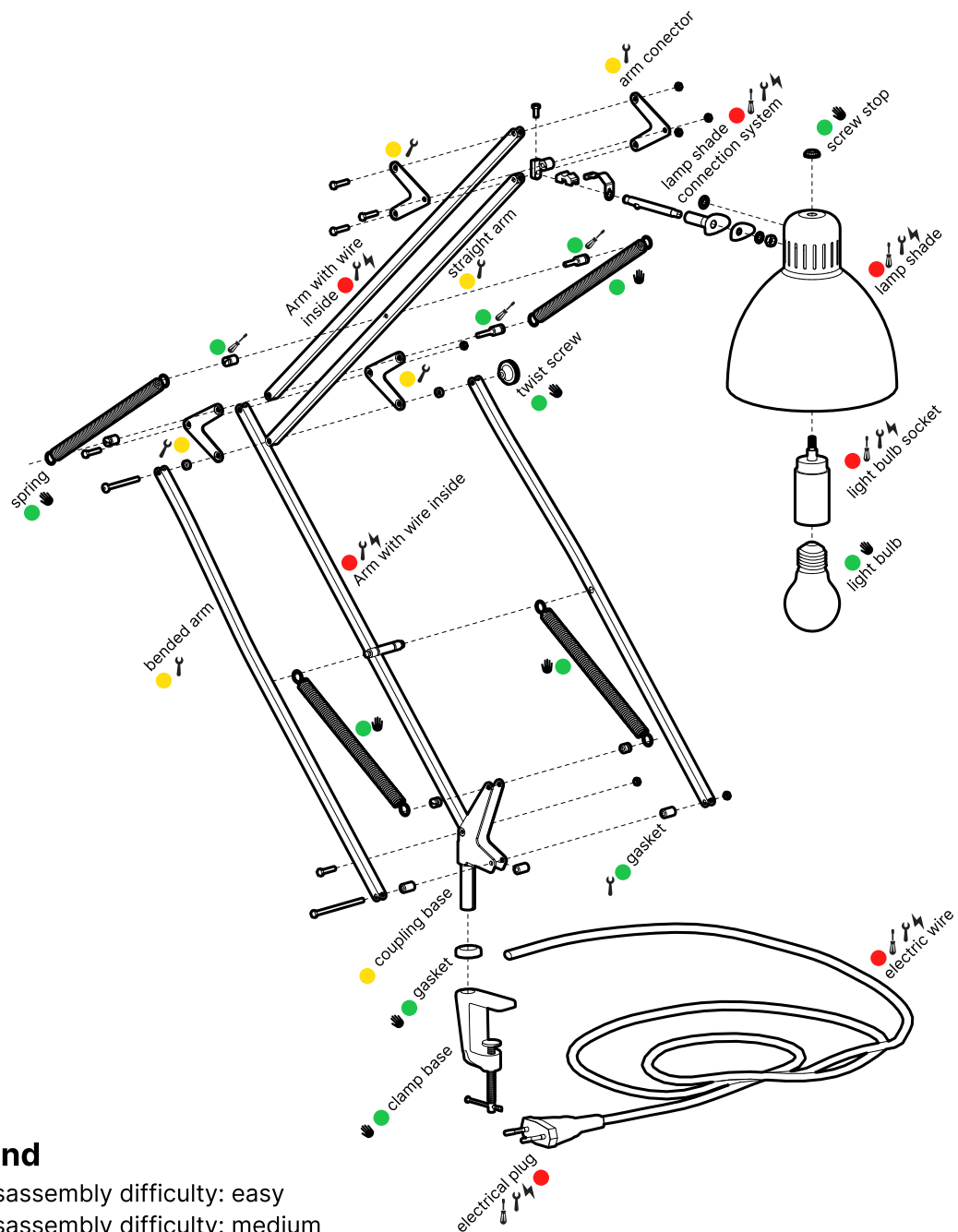

### Legend

- Disassembly difficulty: easy
- Disassembly difficulty: medium
- Disassembly difficulty: difficult



## Accessibility Analysis

The Luxo Lamp consists of 7 major assemblies:

Structural arm with electric wire, hollow structural arm, springs, clamp system, lampshade, bulb, and electric wire.

The bulb can be replaced easily according to the user's needs and demands. The clamp system is easy to adjust for the user. The lamp's position can be changed and it can be used on different surfaces like working desks, dinner tables, etc.

A hollow structural arm has the advantage of being light, it is made of metal and is hollow. This hollow part is used to hide most of the electrical cable, thus providing a cleaner appearance.

The two springs positioned outward of the arms are easy to replace with new ones when they are damaged. But, the one in between the arms is harder to replace because the arms have to be disassembled to replace it.

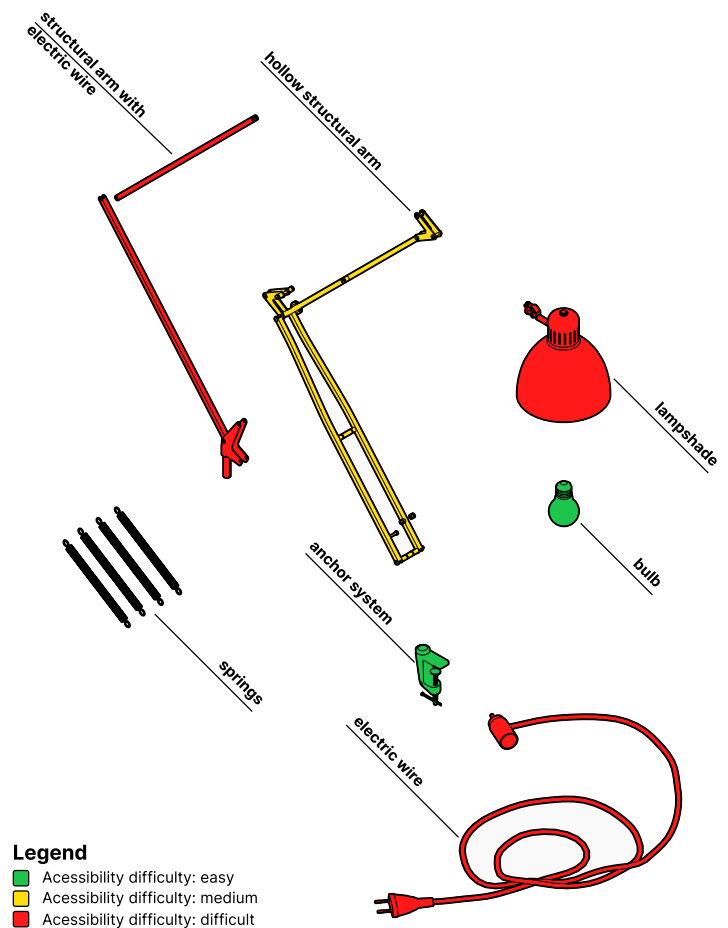

# Study luxo

## General scheme

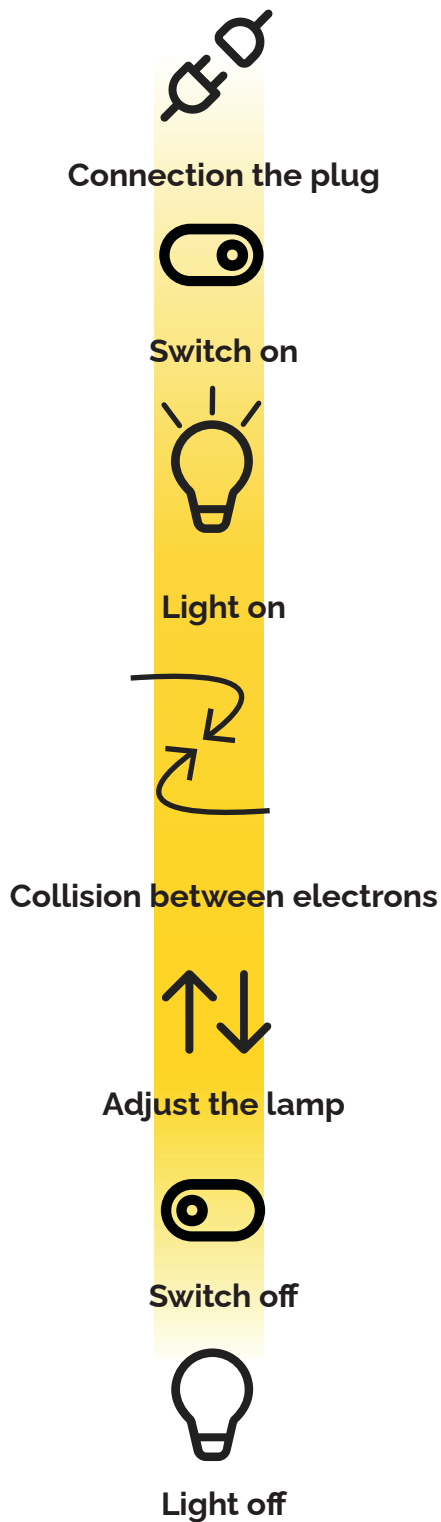

The use of the Luxo lamp starts with inserting the plug into the socket. Then, by switching it on, collisions between the electrons are ensured and the lamp lights up. The positioning of the lamp is adjusted according to the purpose of use, the area, and the anthropometric measurements of the user. After use, the lamp is switched off by pressing the button.

# Essential scheme

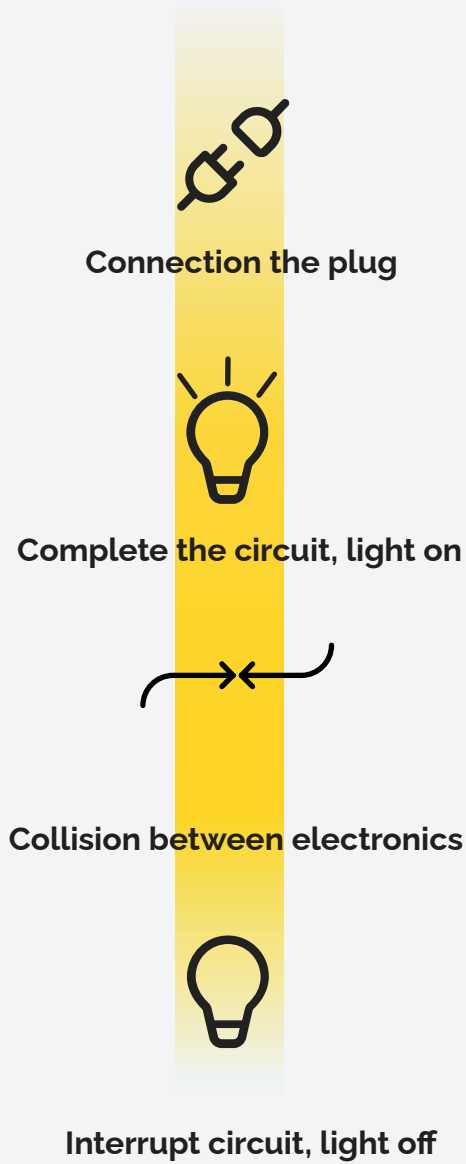

*Designer*

**Jac Jacobsen**

*Product*

**L-1/Naska/Anglepoise**

*Designing period*

**1936-1937**

# Current working scheme

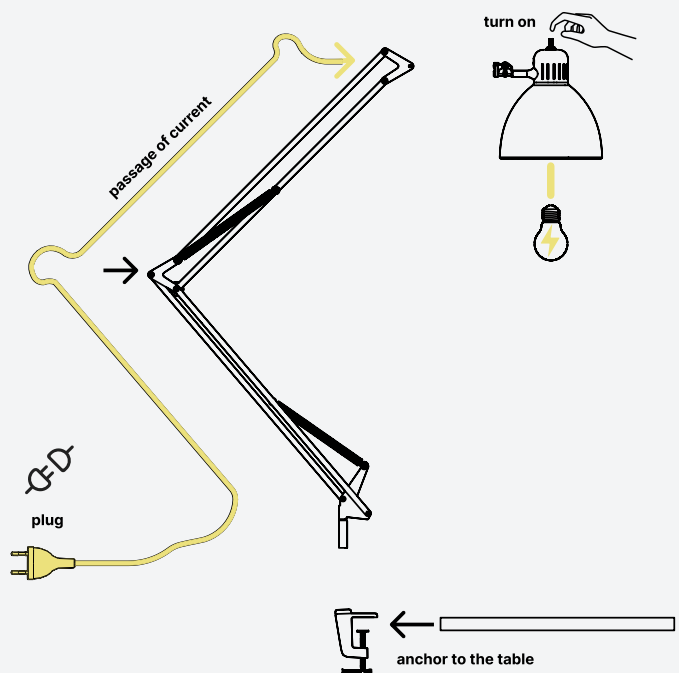

# Background analysis

The Luxo lamp can be used on surfaces by using different bases. These different bases also allow the lamp to be used for different purposes such as reading, working, and ambient lighting.

After the lamp is plugged into the socket, it is adjusted according to the activity to be done and it's ready to be used by switching the button. It can be used during the day when the light is not enough or the weather is bad. After dark, it can be used until the activity ends and it can be easily switched off.

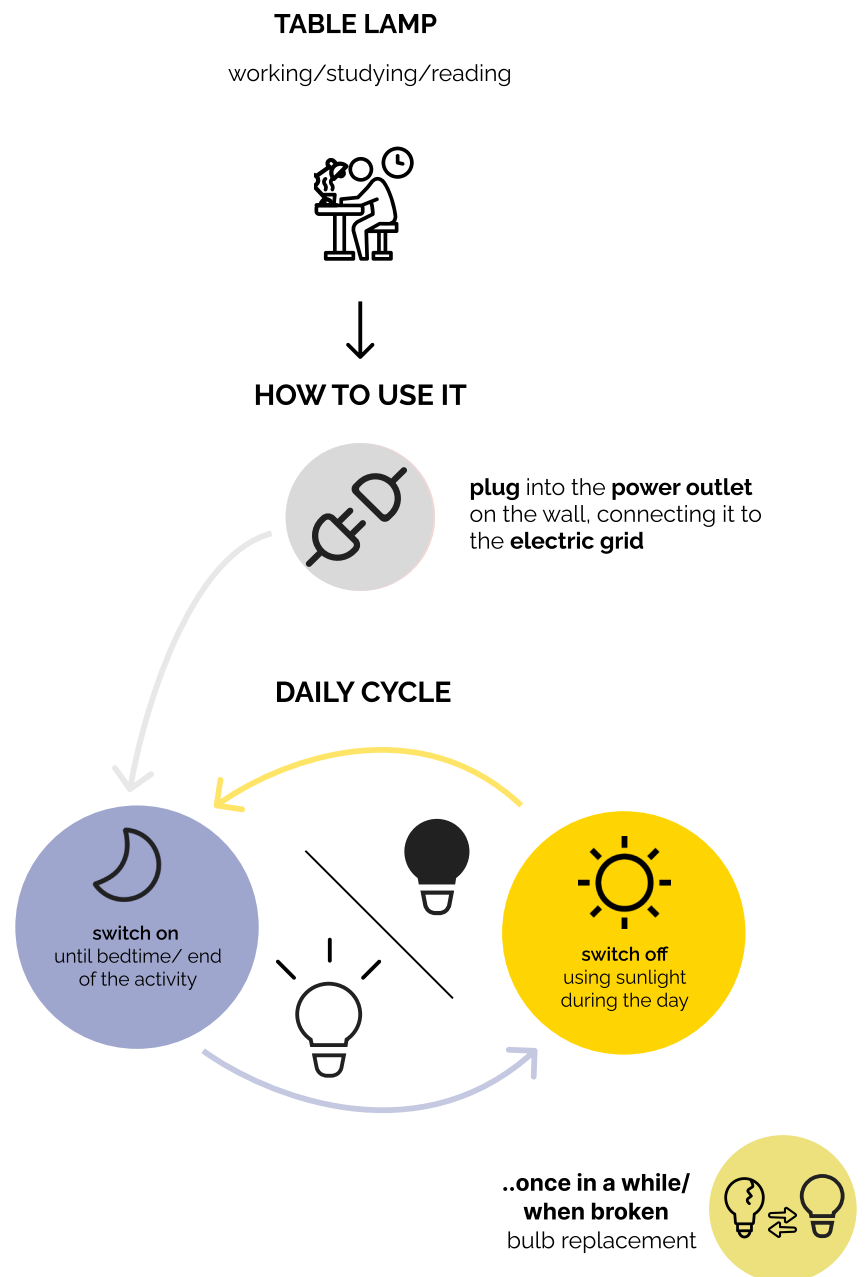

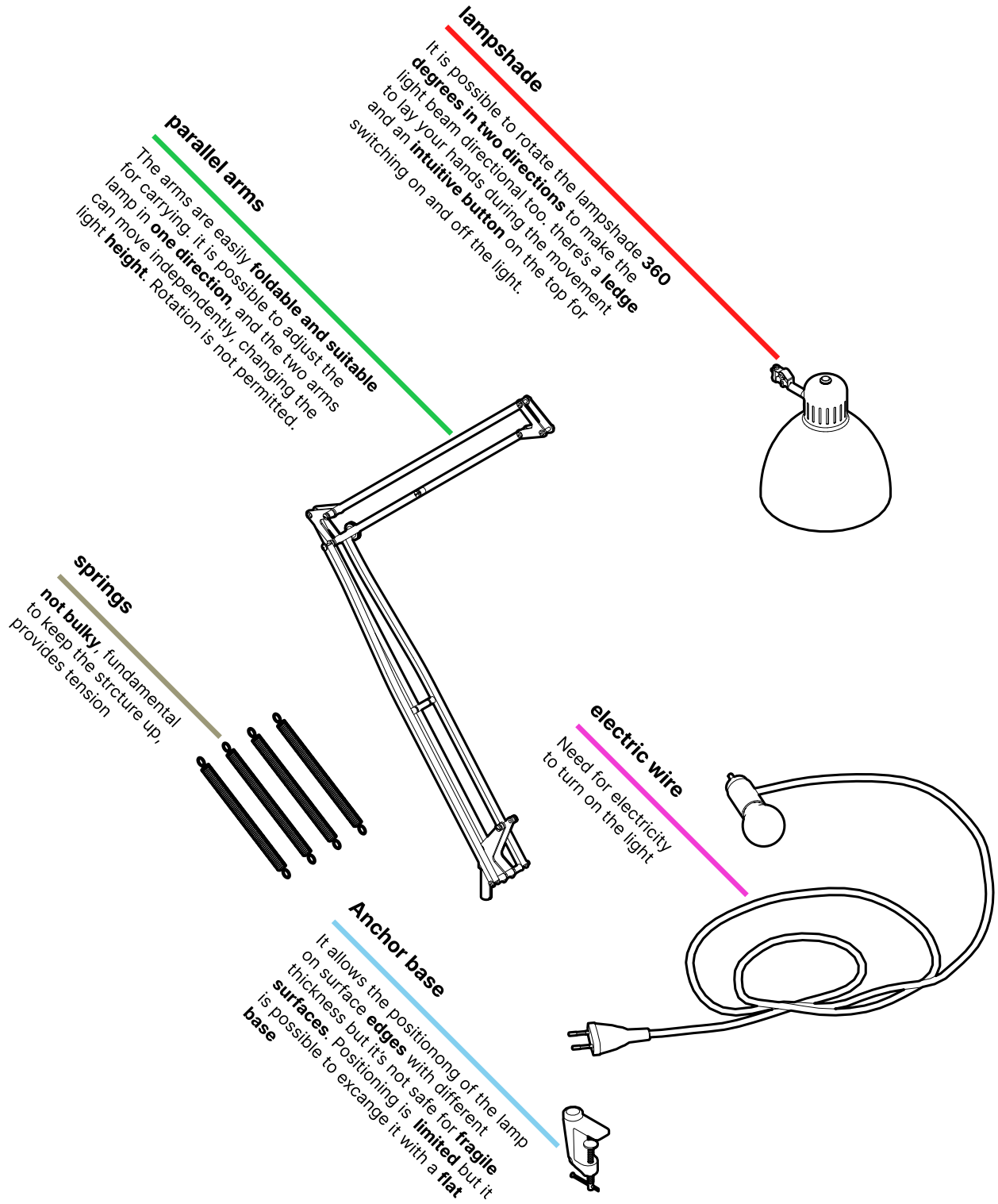

## Emotional and concept aspect



### **Shape**

The body is adjustable, this allows the use in various situations. Most of all the components are visible, light and essential in their form.

# 4/5

### **Shape Truthfulness**

The components that make up the lamp are essential and show their function, this makes the lamp adjustment intuitive.



### **Function**

When the light is on, a cozy, warm and at the same time focused atmosphere is created.



### **Light**

The light beam is highly directional and without glare or flickering. It evokes a sense of focus and warmth.



### **Material**

The metal components have a smooth and cold surface, the metal is painted and different color options are available. The material gives the lamp a feeling of solidity.

# 3/5

**Versatility**

Thanks to the clamp base the lamp can be attached to different surfaces this allows the lamp to adapt to different use cases. The versatility is reduced because the light intensity, temperature and color aren't adjustable.

# 4-5

**Ease of use**

The position of the light switch is intuitive since it's near the lampshade.

The clamp base it's easy to attach to the table. The tension on the arms is low, thanks to this the lamp is easily adjusted. The lamp is light and easy to move.

## Parallel arms

- Flexibility of movement

The independent **Rotation** of different parts of the structure is not possible due to the types of **constraints used**, the constraints allow a vertical movement

## Lampshade

- Swivel and movement

The user can adjust the lamp by **grabbing** the lampshade, the shape is easy to grab and the constraint used allow the **redirection** of the light beam

## Tension system

- Precise tension, easy to replace

The **springs** are the component that provide the tension needed to keep the structure in position, since they can deteriorate with time **changing them it's easy**.

## Lamp base

- Small and interchangeable

The clamp base has a small **footprint**, but it's not safe for **fragile** surfaces and positioning is limited to **edges**, the base of the structure has a coupling system that allows the insertion into a flat base by the user

## Wiring

- Electricity Needed

The light **depends** on the constant supply of **electricity**, provided by a cable plugged into a socket

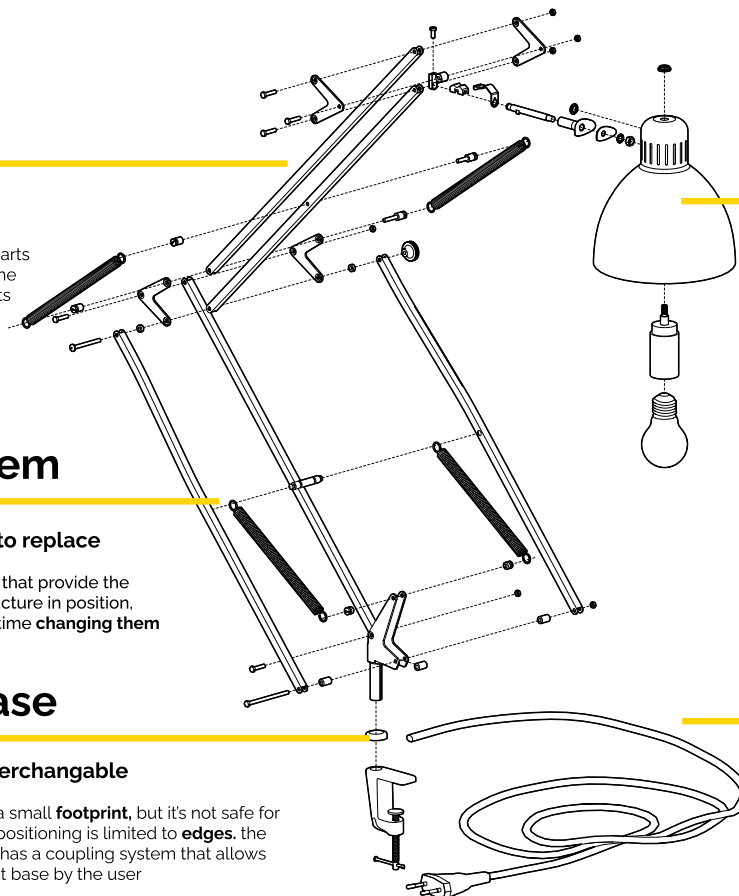

## Connection with luxo

### ***Easy to fix***

Components are easy to find  
and easy to repair

### ***Essential shape***

Form and function are declared  
directly and explicitly.

### ***Context of use***

Context of use designed and  
declared. Little flexibility.



Study

Concept



## Concept system

### ***Problem***

The original Luxo lamp was created thinking of working on paper, but nowadays people work on laptops, they work remotely and in alternative workspaces, people feel unconnected while they're physically apart. Since the paradigm has changed the lamp should change too.

### ***Idea***

The idea is to rethink the relation between the lamp and its new user, "the modern worker". Increase work efficiency and workers wellbeing.

### ***Possible solution***

Variable light beam focus, light to mitigate eye strain, reduce smartphone usage, foldable, battery powered and easy to carry. Reducing sounds, using aromas. Time keeping for Meetings, working hours, breaks.

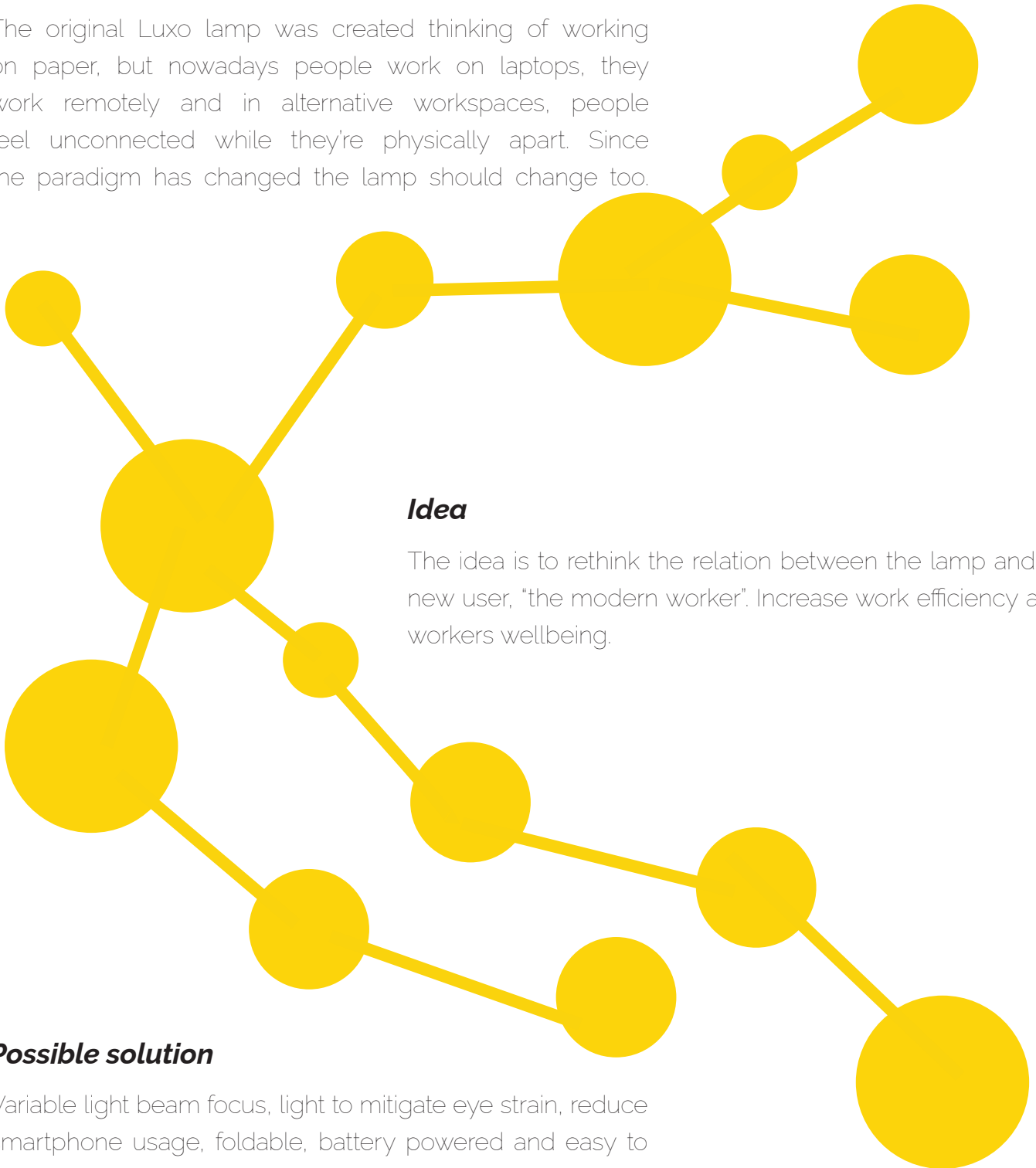

# Scenario

The idea of our concept evolved following some considerations on remote working and how it has changed in recent years. During the Covid-19 pandemic, many people started working remotely, some of them keeping their jobs as employees while others as freelance workers. The essential tool for these jobs is the laptop, used in almost all desk jobs.

**4.8 ML**

Remote workers in 2021

**19%**

Growth of demand for  
freelance (2015-2020)

**70%**

Companies that will adopt  
the hybrid model in 2023

**\* Laptops have become an essential device for smart and office working**

## Damages of working on laptop



## Average days per week working from home after the pandemic ends

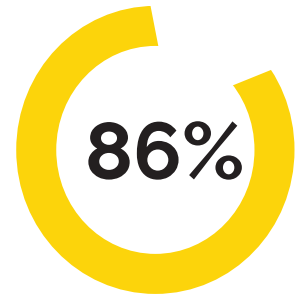
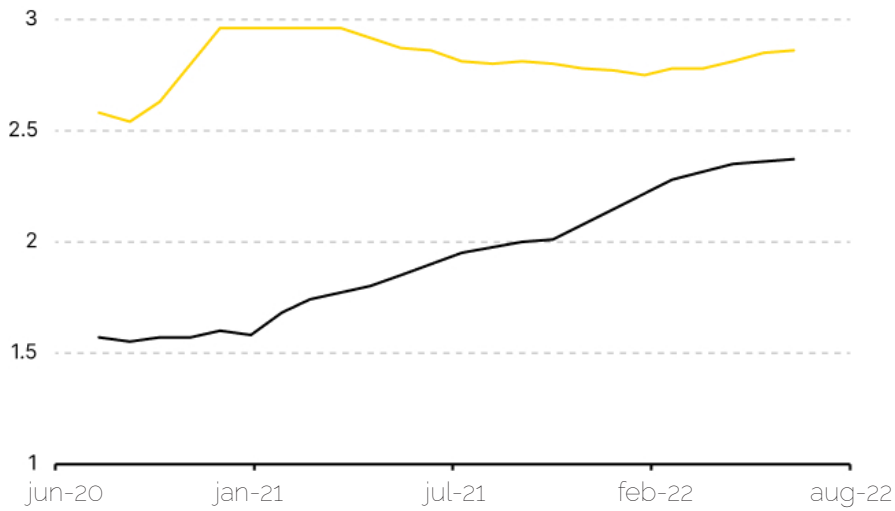

Freelance that work on smart working at home

However, the use of the laptop, especially if prolonged, involves health risks, especially related to lighting and the posture of the worker. The development of home hybrid workstations is partly due to habit changes and partly due to space problems, particularly in conditions of coexistence with other people.

## Current days working from home by different employees

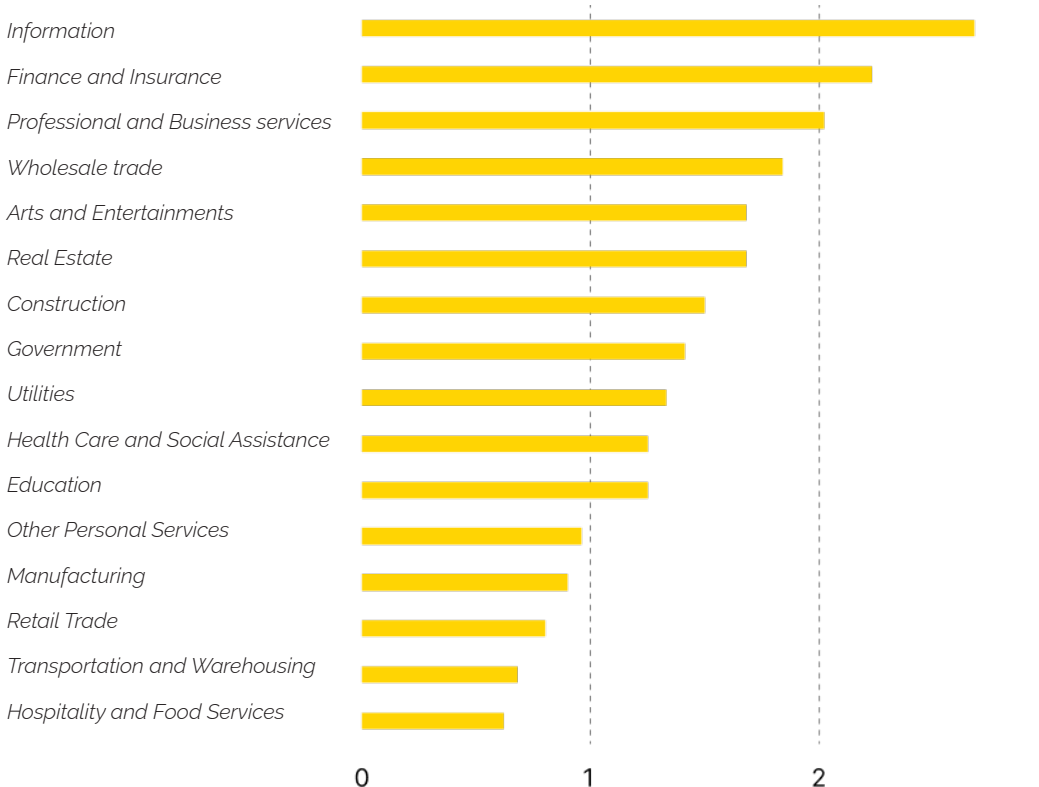

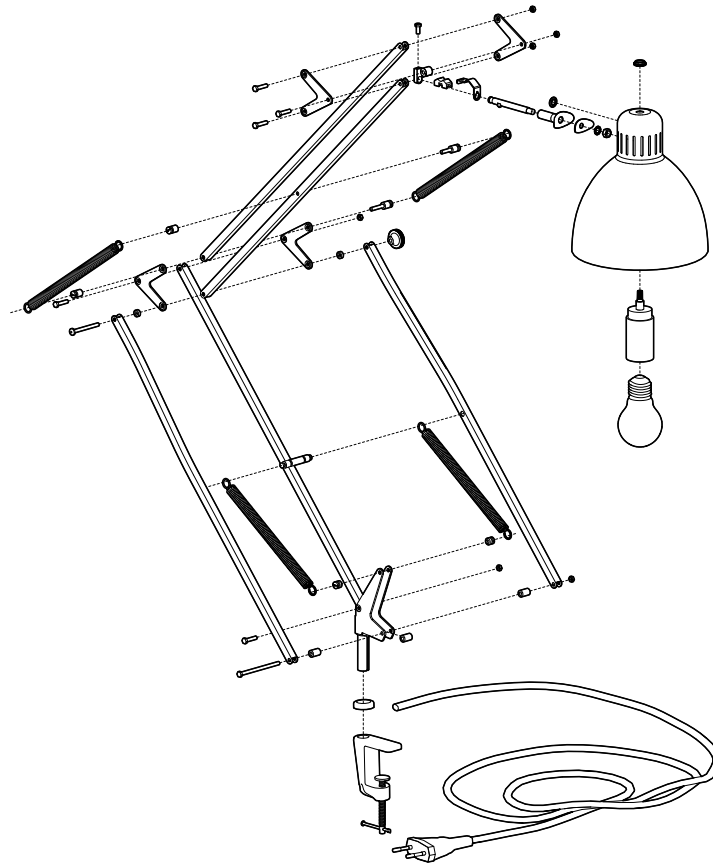

### ***Context of use***

The original lamp is a work light designed to effectively light a surface with the idea of working on paper

Update the lamp to answer to the requirements of the modern work environment

### ***Assembly / Disassembly***

While the assembly of the original lamp is easy the disassembly has some flaws

Allow repairs on the structure by improving the access to the various components

### ***Affordance***

The structure has a high affordance thanks to the mechanical and essential form

The high affordance of the mechanical structure results in a cold and impersonal object

## DIY a practical and emotional solution

### **What is?**

"Do it yourself" ("DIY") is the method of building, modifying, or repairing things by oneself without the direct aid of professionals or certified experts. DIY is a mean of holistic engagement against the focused area of the academic and economic specialization.

### **The IKEA effect:**

It is "the increase in the assessment of self-made products". Numerous studies have found that people give more value to objects made using their time and energy. An increase in the difficulty of the task translates in a higher perceived value, despite the actual result.

Anyone  
can  
perform  
a variety  
of tasks  
rather  
than  
relying on  
paid  
specialists

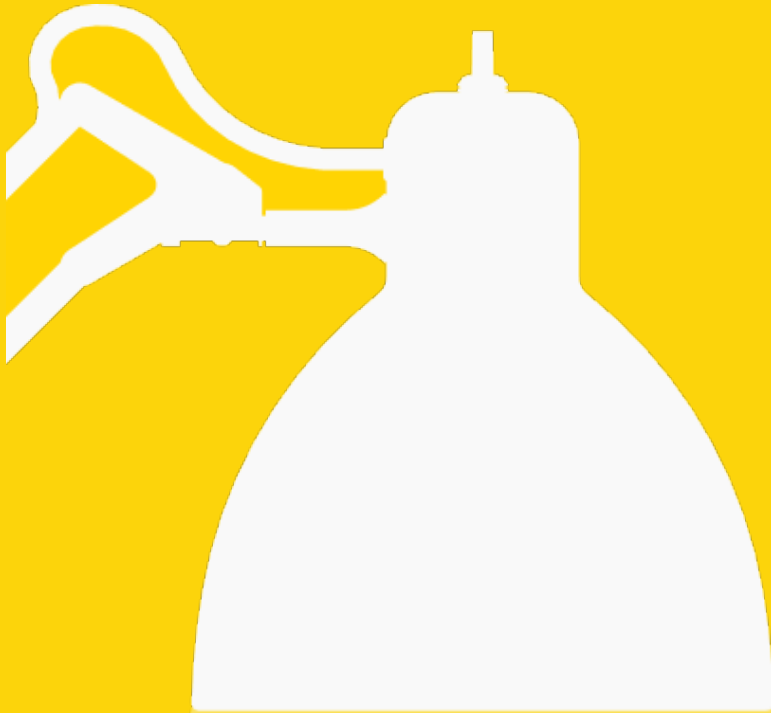

# Concept

## **Build your own work lamp**

The Luxo lamp was created to efficiently light the surface of a writing desk. However, nowadays we work less and less on paper, our workspace is a laptop.

The aim of the project is to create a work lamp that meets the needs of smart workers and of students, giving them the opportunity to build their own lamp by choosing from different modular components. This way, the lamp will not only respond to ergonomic needs related to its function, but will create an emotional bond with the user, regardless of their experience with the world of DIY.

On the sustainability side, the aim of the project is to use materials in the most efficient way and to design a product that is easy to repair.

## Case study

1



### Open e-components

#### System of modular 3D printed electronic appliances

Year: 2013

Designer: Weilun tseng

The project is a modular system where the electronic building elements, in white, can function independently, while being interchanged with supporting parts, in black, giving endless possibilities for producing, repairing and adapting to the users requirements.

2

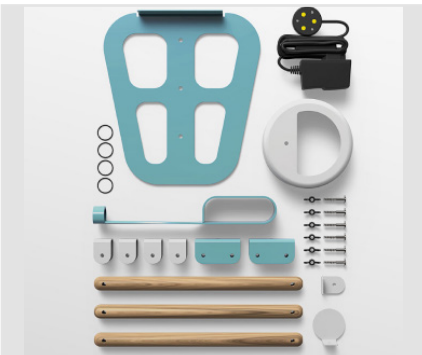

### GIACOLÙ table lamp

Year: 2017

Designer: Delineo design for Zava

A system of elements to create a lamp with the intent of having the user choose the form of the finished product. The kit is made up of: wooden dowels, screws, metal bolts and the light source. The inspiration for the lamp comes from Meccano, a mechanical construction



## Lego 3 in 1

The Lego 3 in 1 is an innovative analysis based on the idea of creating different toys with a single basic unit such as the lego brick. This approach is the basis of many Lego 3 in 1 toys which give children the opportunity to build three different things with the same set of bricks.

It also inspire children's creativity, encourage curiosity and teach them the basics of building and design



## Wooden Table Lamp

Year: 2020

Designer: Frans

The wooden lamp is a shared file in the site Printables. The lamp is an unique and customizable lighting solution that allows you to build your own lamp using wood rods of either 24,5 mm or 25 mm in diameter. The lamp is available in two versions, one with feet and one with a clamp, so you can choose the one that best fits your needs and preferences.

The wooden lamp is a unique and creative way to add a touch of warmth and personality to any room in your home. With a little bit of creativity and some basic DIY skills, you can create a one-of-a-kind piece that is both functional and beautiful.



# Guide lines

## Practical



### User welfare

The lamp helps in reducing eye strain



### Assembly

The assembly is left to the user



### Modularity

Easy to repair thanks to easily replaceable components

## Emotional



### Customization

Adaptable to the needs of the specific user



### Object to thing

Creating the object increases its emotional value



### Barriers to entry

The construction is simple and it can be done with different materials

# Personas

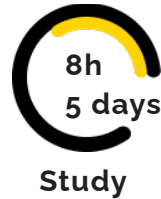

days x week  
hour per day

Experience with DIY

Experience with technology



## Michele Lovaglio

### About

Michele is a young engineering student from Lecce with a passion for video games. he is an introverted and tidy guy, but creative and with great dexterity. He lives alone in Turin and spends a lot of time in front of the computer to study and to play videogames online. He works mainly on his desk which is little and not very equipped, especially for when he's working on books and laptop at the same time. during the night he spends a lot of time playing videogames, which is why in the morning he's always tired and not concentrated.

### Description

**Age** - 21

**Job** - Management engineering student

**Workspace** - Home/bad-room

**Personality** - Introvert/Passionate/Introvert

**Hobby** - Video-game/Basket

### Needs

- Try to avoid playing videogames all night long
- Find a way to concentrate better while studying

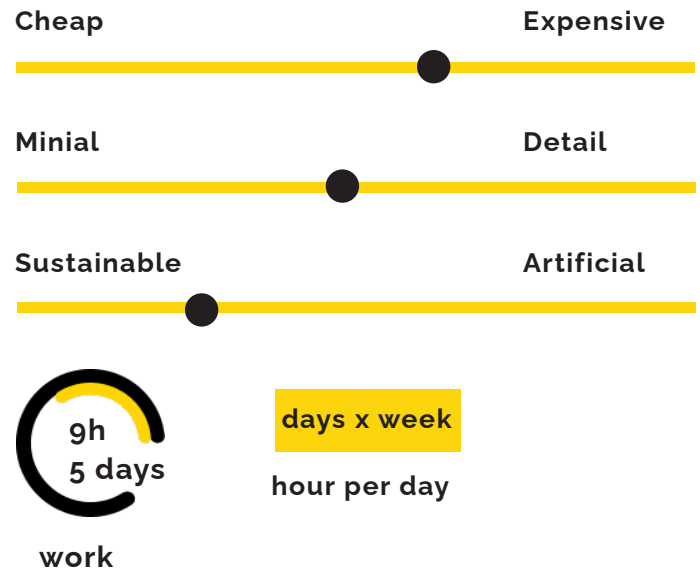

Experience with DIY



Experience with technology



## Sofia Loreti

Sofia is a young consultant who has recently started the freelance profession. she has always been a practical and determined girl, but slightly distracted and not very organized, which is why she can hardly manage her work commitments without finishing late at night. Despite living in a small house, she likes to change workstation frequently, Moving from the sofa to the bed and avoiding the desk, which is covered in papers and objects and therefore impossible to use. As a quiet person, she is constantly looking for the most comfortable and suitable solution for her. in her little freetime she likes to rest in front of the tv.

## Description

**Age** - 36

**Job** - Freelance consultant

**Workspace** - Home/living room

**Personality** - Messy/Empathic/Hardworking

**Hobby** - Pilates/Cooking

## Needs

- Reduce eye strain and back-pain during work
- Work comfortably from all places of the home

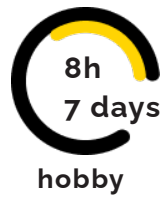
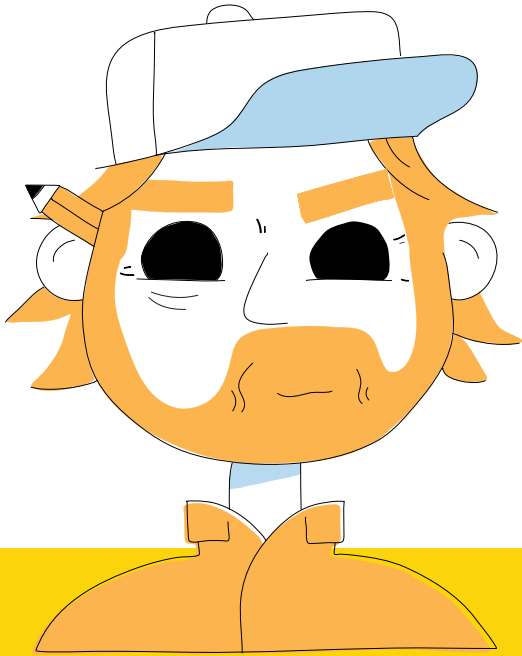

**8h**  
7 days  
days per week  
hour per day

**Experience with DIY**      **Experience with technology**

## Stefano Lavarini

Stefano is an elderly retired gentleman. After a life spent as a clerk in the city bank, he decides to express his creativity by making objects in his studio in the attic obtained from the room of his son who had left the house. he loves to spend his days in the attic even if the room is not well illuminated and he has problems on the detailed works due also to his astigmatism. Stefano has a passion for gardening, painting and likes playing the guitar. During isolation he has often found himself making computer video calls and often reads forums and watches tutorials because he likes to build things but sometimes he finds himself uncomfortable because he doesn't know the technology very well and has no one to ask. He knows Leroy Merlin very well and often goes there to create small Christmas presents or to maintain the house which is getting older and older.

## Description

- Age** - 65
- Job** - On pension
- Workspace** - Attic garage
- Personality** - Perky/Extrovert/Practical
- Hobby** - Garden/Painting/Playing guitar

## Needs

- Easy to build the lamp
- Lamp which give a correct illumination in a attic or garage
- Ease eye problems



# Journey map Stefano

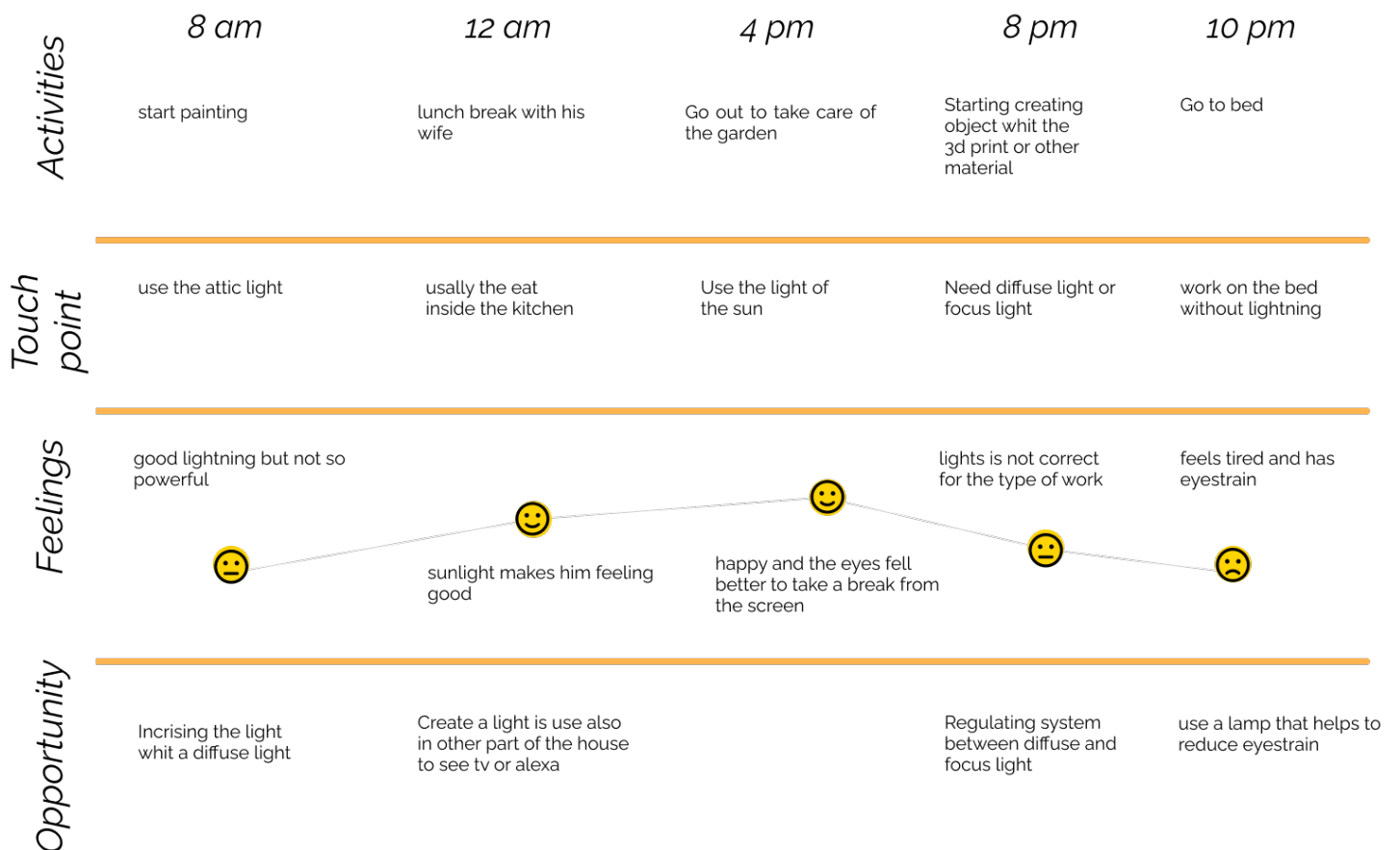



# Journey map Sofia

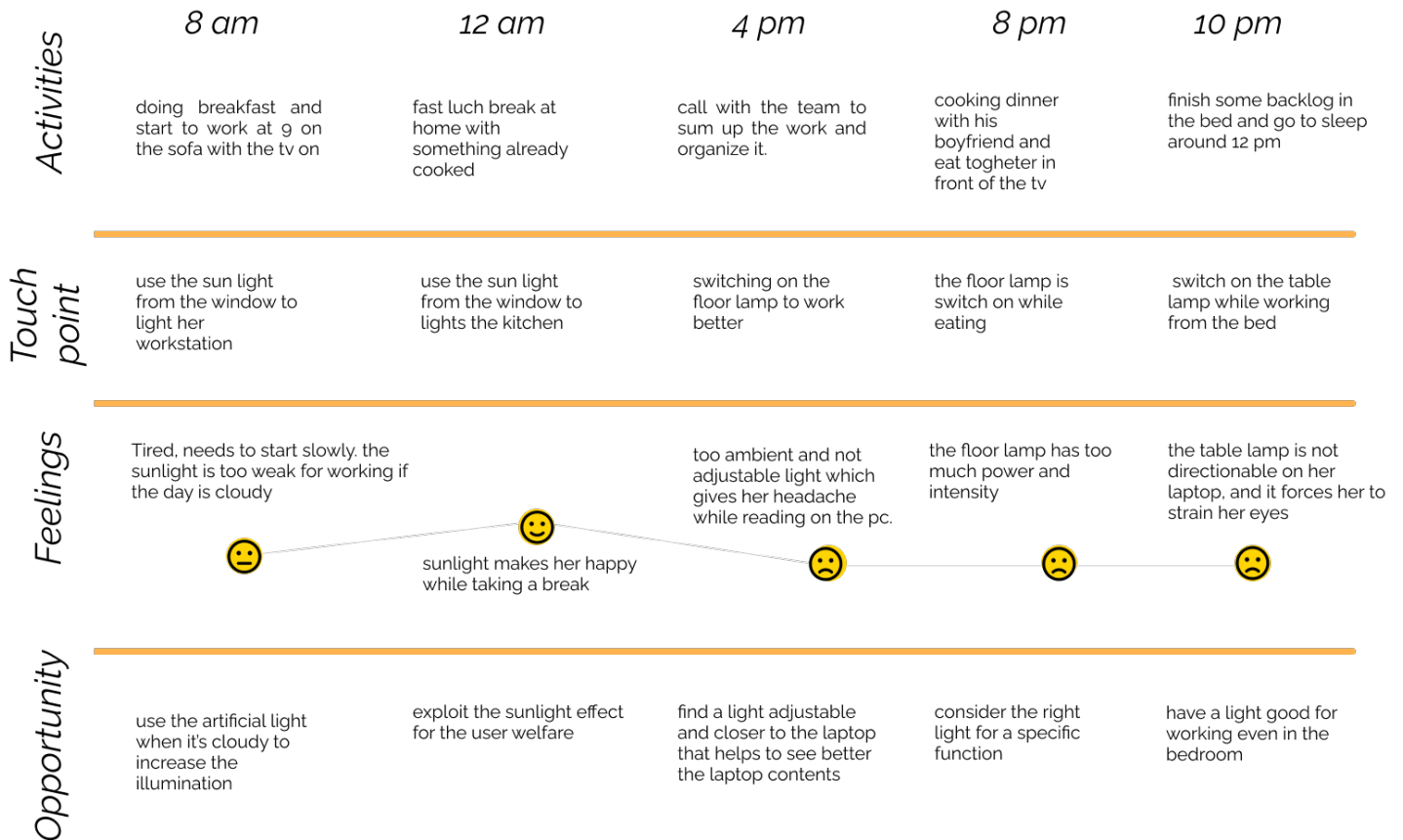



# Journey map Michele

	8 am	12 am	4 pm	8 pm	10 pm
Activities	waking up and going to university	lunch break with some friends, sometimes looking videos at the laptop	coming home and studying on the desk with his laptop	if his roommate is not at home he eats in front of his pc playing videogames	continue to play videogames until late night
Touch point	using the university rooms lights	if it's warm eating outside under the sunlight	switch on the desk light to study	use the same light for videogamesc	stay on the bed without lightning
Feelings	good lightning but not so powerful. He is not feeling concentrated	sunlight makes him feel good but the sunlight creates too much glare	light is not adjustable to change focus from laptop to books	lights is too cold for the pc screen	feels tired and has eyestrain
Opportunity	light focus on the space activities	control the shadow created by the light on the screen	control the shadow created by the light on the screen	lights suitable with the pc screen	use a lamp that helps to reduce eyestrain

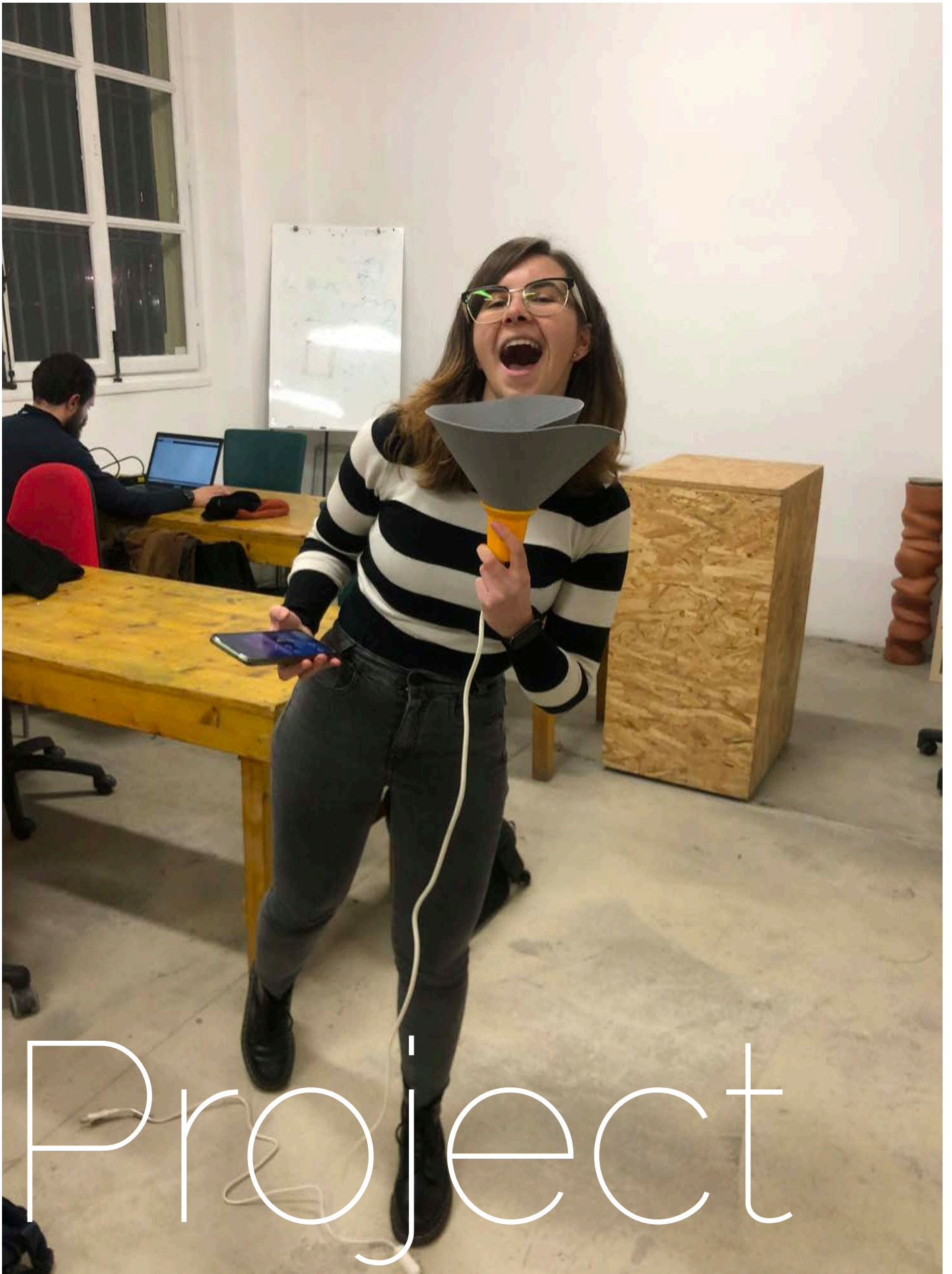

# Project



## Needs, requirement and performance of our lamp

To start designing Lumade we analyzed the needs relating to the users; then the requirements of how the lamp should respond these needs and finally its performance, which communicates the requirements through the design.



### Usability

Different ways to assemble the components according to the specific needs

Adaptable shape



### Ease of movement

The mechanisms for movement are naked

Three different types of bases to adapt it to different situations, there can be used to easily move the lamp



### Customization

The lamp declares its function and its possible movement

The lamp is easy to move inside the house, it's adaptable to different spaces



### Different light beams

Openable lampshade to change the beam of the light

Two different way to illuminate, diffuse and focus light



### Visual comfort

Light studies includes directionality of light, luminance distribution, luminance. Respect the standard EN 12464-1:2011

Reduced glare and shadows, Intensity and contrast that isn't too dim and not too bright to wash out the screen



### Adaptable temperature

3300 k (warm) - 5300k (cold)  
Temperature range

Light temperature that doesn't strain the eyes, with reduced blue light

	<b>Weight</b>
---	---------------

Weight < 2500g

Lightweight, the shape is widely

	<b>Sustainability</b>
---	-----------------------

Reversible junction, no glue

The joints of the object are reversible and easy to separate

	<b>Recyclable</b>
---	-------------------

Wood, thermoplastics

The material used are recyclable.

	<b>Ready made</b>
---	-------------------

The structure is effective on its tasks despite is made of already made components

Materials are easy to find and partially ready-made

	<b>Open-source</b>
---	--------------------

The project can be modified and improved by anyone

The components that aren't ready-made are open-source, easy to modify and to create

	<b>Modularity</b>
---	-------------------

A repeatable component allows the different configurations and movements

Adaptable to the current needs of the user like using as a wall lamp, desk lamp or stabilize with a clamp

## legend

needs

requirements

performance



With a solid foundation of customer needs and performance, we now begin to build the structure of our project, creating a lamp that will not only illuminate spaces, but also enlighten creativity.

## Essential and General Scheme

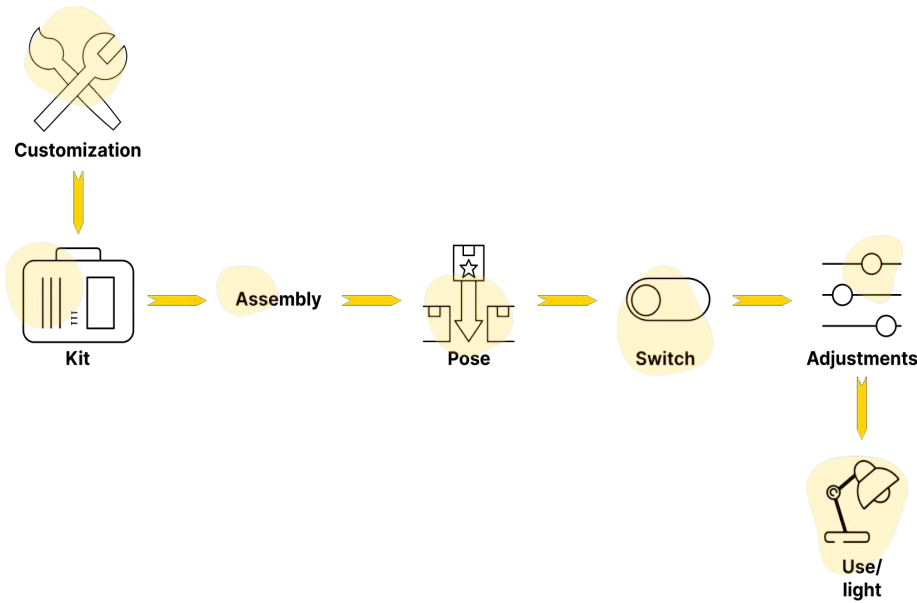

Compared to that of the Luxo, our essential scheme starts from the customization of the components, by choosing them online or from the instruction papers. In this way, it is possible to assemble the lamp into the chosen

configuration without having necessarily all the pieces if they are not required.

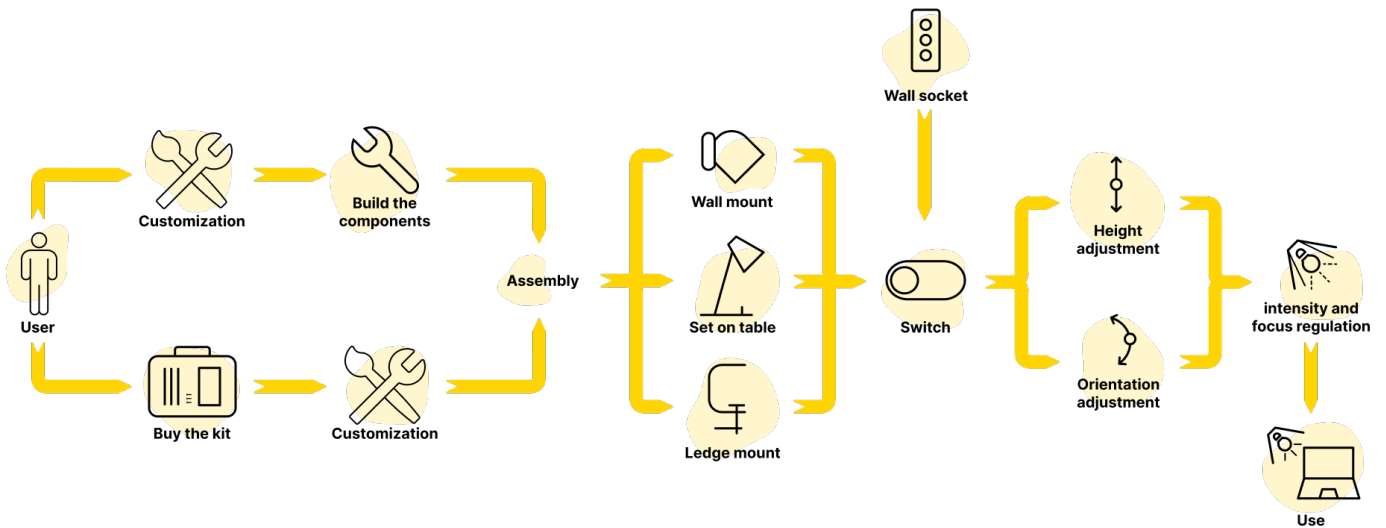

The general scheme explains better how to obtain the kit components, that is building them manually or buying them ready for the assembly. Moreover, this scheme shows

the three different bases provided, and the technology used to light the lamp (with a wire and a socket), which is the same of the Luxo.

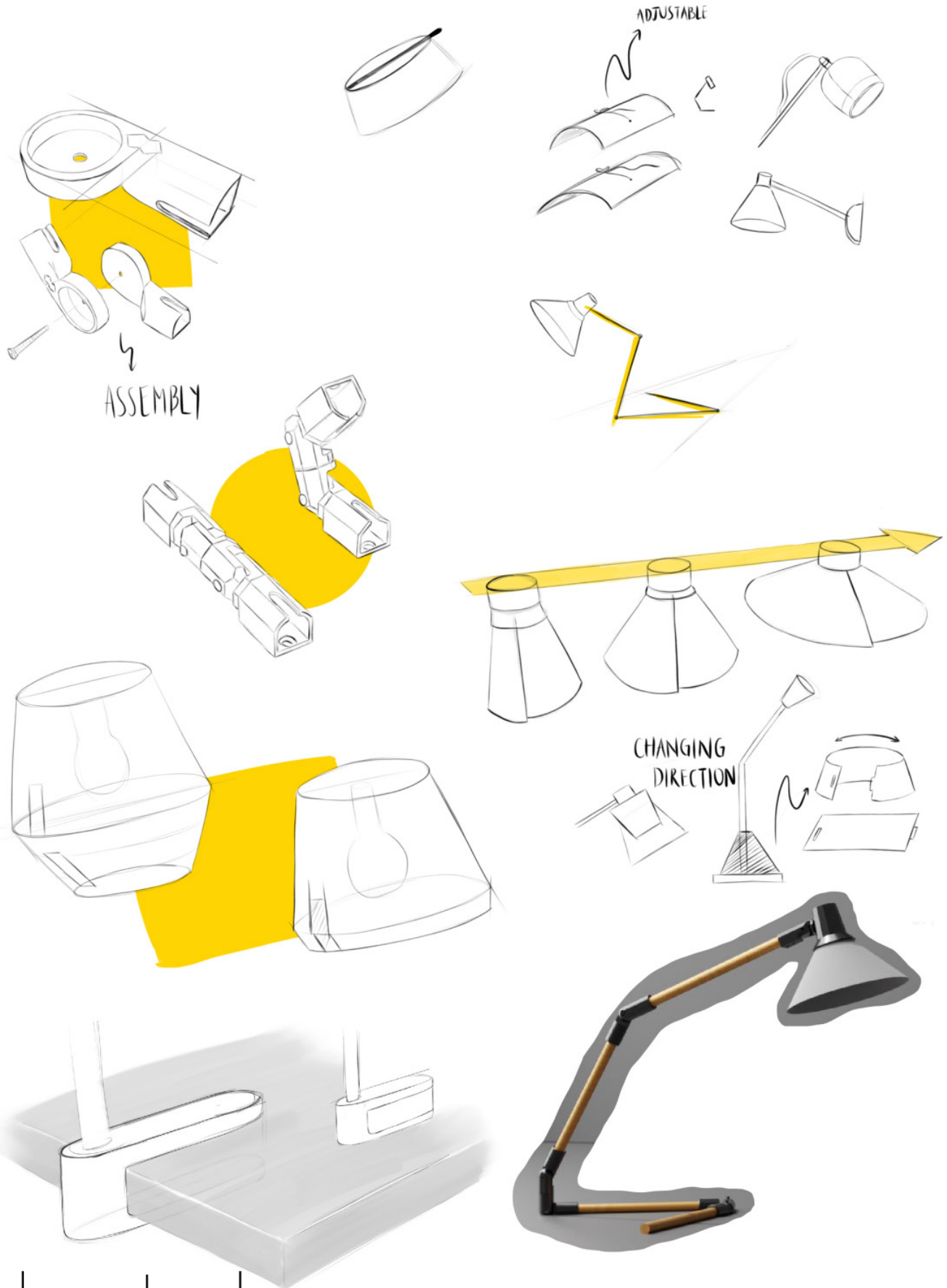

sketches

# \* A lamp kit with infinite configurations

As already mentioned, our project intends to start from a series of modular components that can be assembled differently to create different configurations of the same lamp. In particular, three different support bases were considered, namely the one on the wall, the one on a flat surface and the clamp one. In fact, the use of different bases directly responds to problems of space, comfort and size which refer to our personas. The design of the bases was conceived considering the high accessibility of its components and the ease of assembly. It would be possible to create different configurations based on their function and especially on the required workplace, without involving the use of complex tools and mechanisms. Since the components are easily found on the market, their possibility of customization is quite wide.

## Different bases for different needs

This applies to all pieces apart from the joints which, are original pieces, can be purchased online or 3d printed. Furthermore, the adoption of a parametric design guarantees the customization of the pieces and their dimensions even in the modeling part. To help with the configurations, a booklet has been created containing all the assemble instructions and some possible configurations by choosing different shapes, joints, materials and color combinations. Despite this, the project aimed to be open source and therefore modifiable by anyone.



*surface*



*clamp*



*wall*



## How to build the lamp

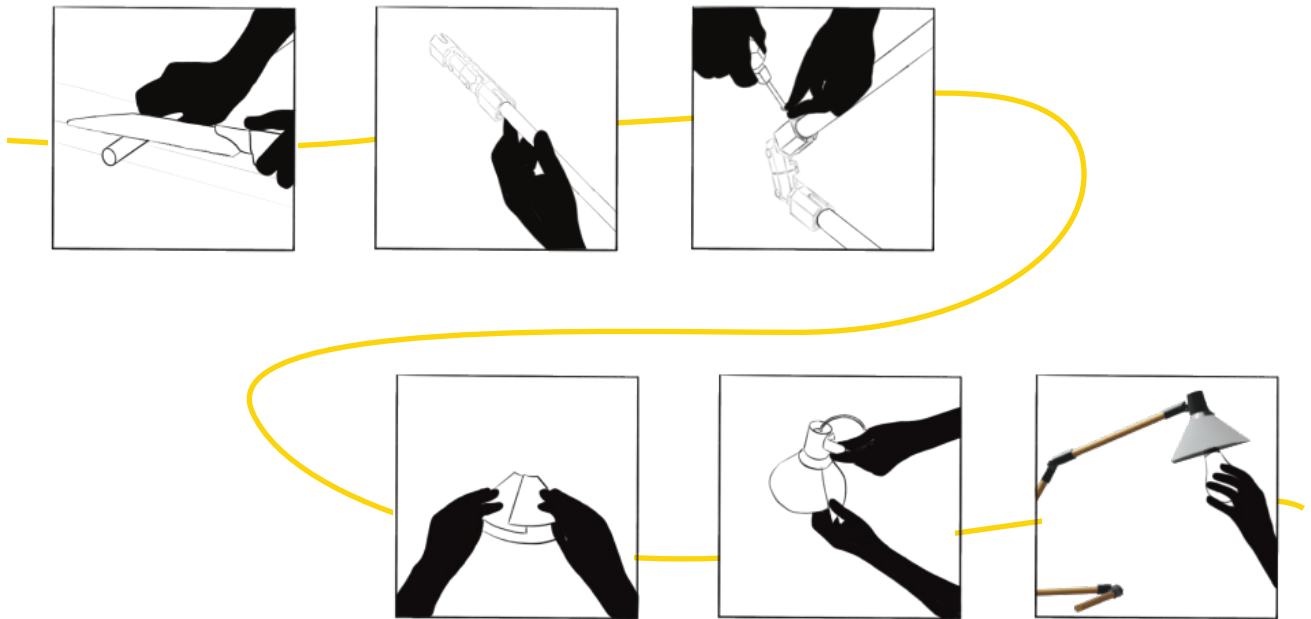

## Use of the lamp

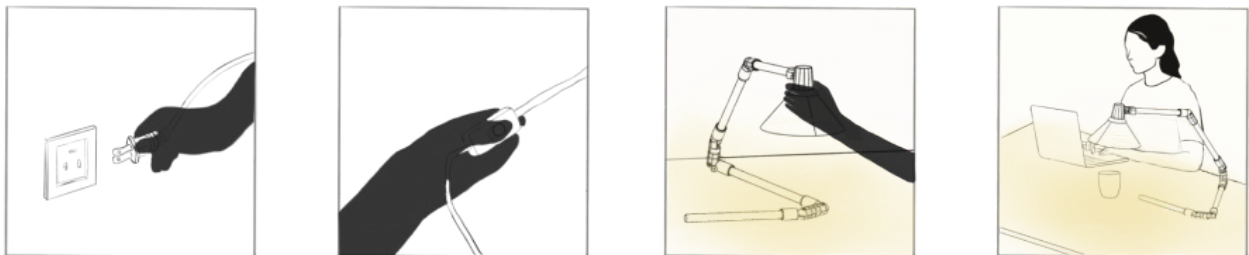

## Ergonomic studies

After conducting ergonomic studies, we researched the most common dimensions of the desks on the market. This research was used to understand whether, regardless of the desk sizes, the maximum illuminated work area was still respected.

From the research, an average of three different desk sizes was established: small, medium and large. The large desk is the only one that includes the entire occasional work area, i.e. the one with the maximum grip, and can accommodate various work tools such as laptop, books and notes. Even small and medium-sized desks allow space for several tools, such as a book and a laptop, but with the occasional work space reduced, if not absent as occurs in the small one. For this reason, small and medium-sized desks are the most likely to hold a base clamp lamp, even if this is linked to space needs that does not necessarily have to do with the size of the desk.



## Average desk measurements

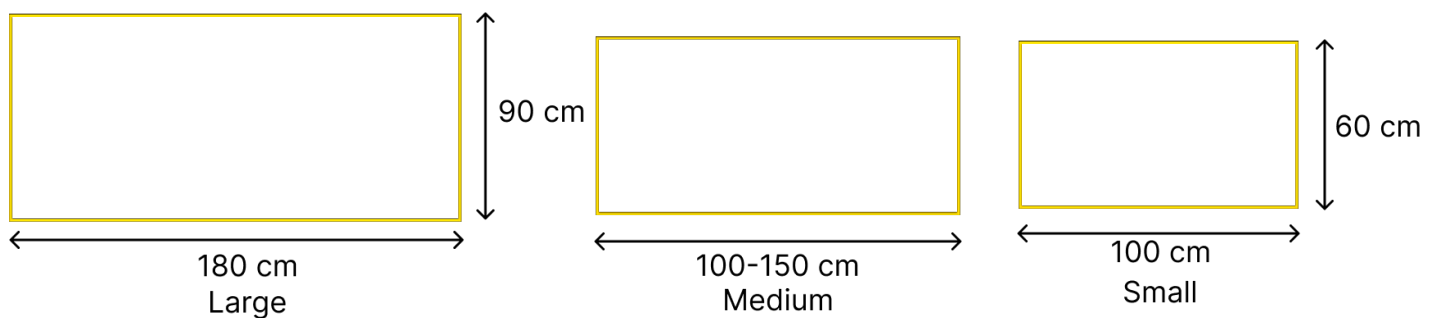





# Joints

## Functions

At the heart of the design is the idea of creating a series of modular components that can be assembled together in different ways. The connections have the important role of connecting, joining and enabling the movement of the various arms of the lamp. On a static level, they must support and hold the lamp and its weight.



### ***Problem***

The lamp needs a unique joint that is adaptable to any type of movement and does not break easily. Furthermore, the movement must be made with ease and fluidity in order to have greater usability of the object.



### ***Idea***

The idea is to create friction joints that are durable and easy to maintain. The joint have a single adaptable coupling for the various parts of the object and its different movements.

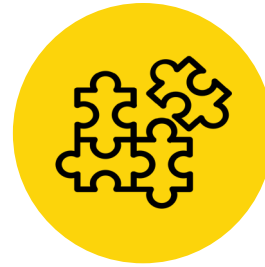

### ***Our solution***

Motivated by previous principles, the joints of the lamp have a common coupling at the ends of each rod, to which one/two pieces are added, depending on the movement, to allow rotation around the x-axis or z-axis respectively. The various parts of the joint held together by a screw and a locknut and are separated either by rubber gaskets, which allow the movement to be limited and consequently controlled, or by a plastic pin to lock it permanently.

## Joints studies

### *Ball and socket joint*



### *Ratchet joint*



### *Hinge joint*



Before arriving at the final joint designs, several types of joints were considered. At first, the ball and socket joint was one of the joints that best met the requirements of our lamp, as it allows the arm to move well and easily in all three directions. However, since it is a ball, i.e. a solid with no flat faces, it is more difficult to print with 3D printer; moreover, the joint uses friction to stay in position, but this only works if you have a chain of joints, as would be the case here, so it is not applicable to this project.

Next, the ratchet joint was analyzed, as it has a squarer shape and is therefore easier to handle for additive manufacturing methods. This type of joint is composed of many small teeth, which are easily broken when 3D printed.

## Joints studies

### *Magnetic ball joint*

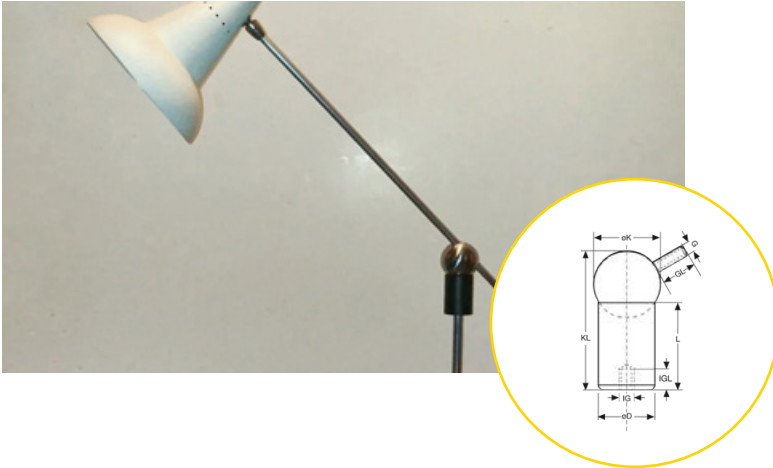

After checking the market for other materials, such as metal, and their price per piece. It was decided to look for another solutions. Hinge joint and magnetic joint are two other proposals that could work for the project from a mechanical point of view, but they require large dimensions if they are to be 3D printed, so they were not the best fit in terms of aesthetic reasons. For this reason they were discarded.

**While the assembly of the original lamp is easy, the disassembly has some flaws.**

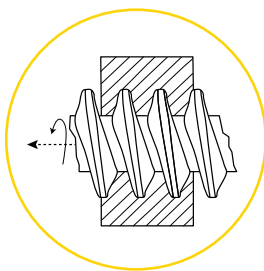

**Screw joint**

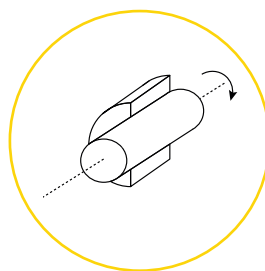

**Cylindrical joint**

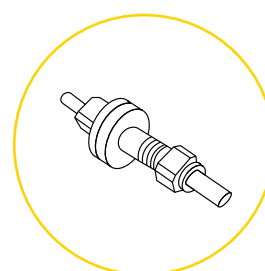

**Front teeth joint**

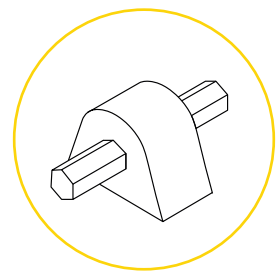

**Prismatic joint**

# Joints Sketches

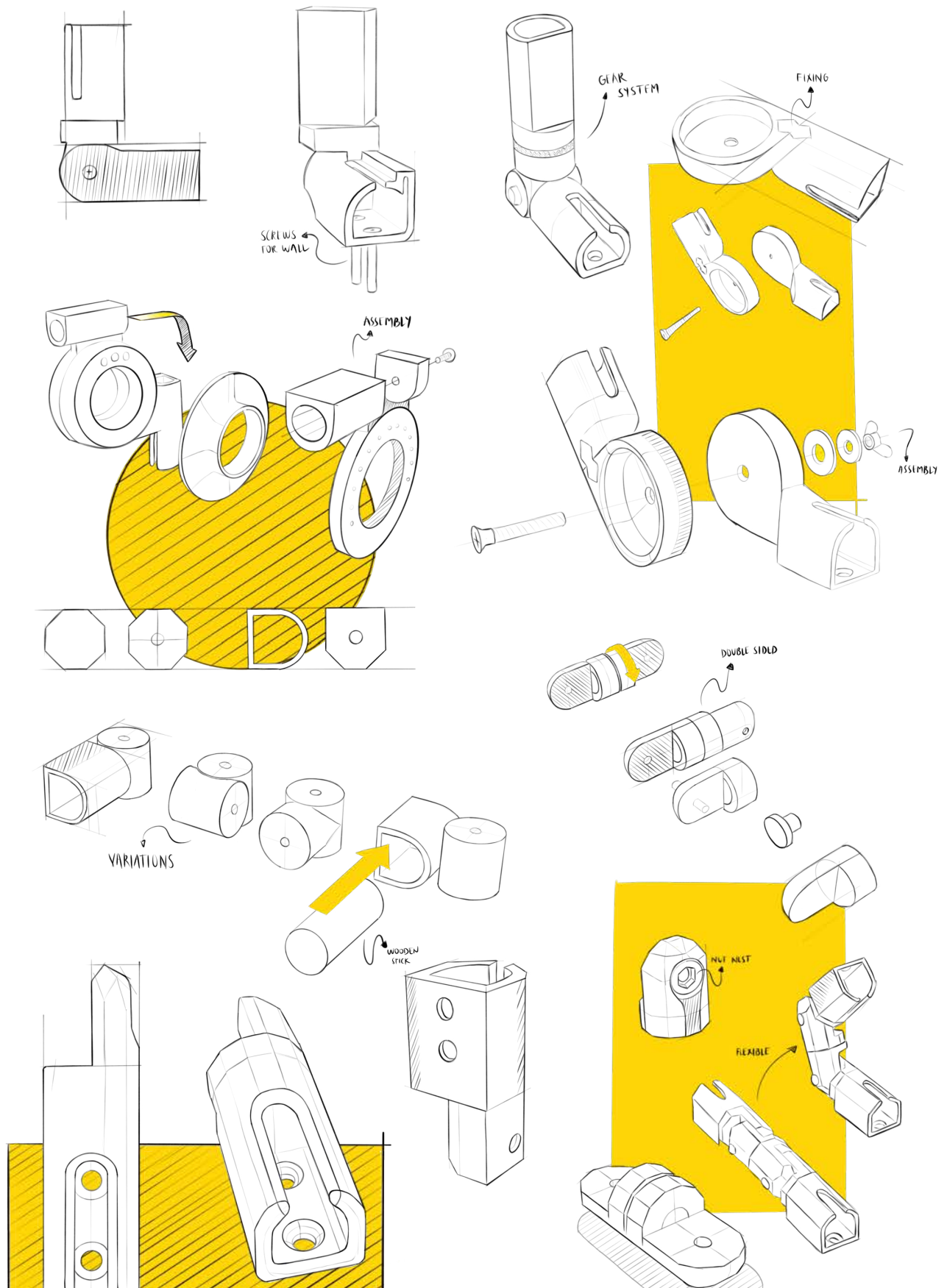

## Material of the lamp

### PLA

PLA, used in the form of a filament for the 3d printer. PLA, or polylactic acid, has characteristics similar to polyester and PET, so it has excellent strength characteristics, is economical and transparent in nature, but can be easily colored with various degrees of translucency and opacity. It is available in many color variations, allowing the user the customization of the piece. It is proposed because it is one of the easiest materials to print, since it does not need a heated bed and can be printed at low temperature (187° C). This allows to have a good level of finishing of the printed object and consequently has a good print yield. In addition, objects printed in PLA are durable over time.



### Wood

Wood, that is a, durable and economical material; it is also a good insulator and retains moisture. For these characteristics it has been used for the structure of the lamp: in particular the function are used rods with a diameter of 2 cm of solid wood of various sizes. It is also chosen for its ability to give the rooms a warm and welcoming atmosphere.



# PP Plastic

Polypropylene sheets, selected for the lampshade. The selected material is ideal due to its exceptional tenacity and tear resistance. In addition, polypropylene sheets are antistatic, relatively resistant to scratches and a variety of chemicals, and it has also stabilised against UVA radiation. In addition, compared to other plastics, polypropylene foils are readily available on the market, both in monochrome and textured versions, in the form of plastic breakfast mats. It also possesses the following characteristics: good strength and flexibility, high resistance to thermal deformation, high dimensional stability, i.e. high resistance to creep, all the properties necessary for an element such as a lampshade.



## Sustainability

The lamp, thus designed, is easily maintainable in the event of breakage, given the ease with which the object itself can be assembled and disassembled, and the great accessibility and availability of the parts that compose it. In particular, the use of 3D printing for the realisation of the project, allows the components to be made, thus producing or replacing only those that are necessary, without having to print the entire kit each time. In addition, all 3D printed parts are modular and therefore interchangeable. Also from the point of view of the shape, we recommend the organically-shaped joints, where there is a study to optimise the amount of material to be used.

Logo



**LUMADE**

**Bebas Neue Regular**

---

**ABCDEFGHIJKLM  
NOPQRSTUVWXYZ123456789  
abcdefghijklmnopqrstu-  
vwxyz123456789**



## LUMADE

The typeface used is Bebas Neue Regular for the logo. The Font is sans serif and downloadable and usable by everyone being present in the google font catalog. The letters are characterized by geometricity and rigor which guarantees them a certain legibility.

The name is made up of the abbreviation of the Italian word "luce" which means light and the English word made. The created word "lumade" to recall the idea of creating and doing typical of maker-spaces and that of the subject matter of the course, that is light.



# LUMADE

## Black and white version



**LUMADE**



The pictogram represents the key to the project concept. The concept aims to review the Luxo lamp, designed as a table lamp for paperwork, from a modern perspective. Social changes have radically evolved our habits and our working stations by centralizing all the activities that in the past took place in an analogical way but today, digitally. Starting from this concept, the lamp was made with a lampshade that opens and closes in such a way as to be able to change

the beam of light with which the work surface is illuminated, allowing the user to work both on the PC and paper. The synthesis of this reasoning is translated through a rail mechanism that allows you to slide the lampshade, thus allowing it to open and close. This mechanism has been visually summarized with an icon merged into the letter "L". In addition to the letter "L" the letter "U" is used which together form the word "LU" the first syllable of the Italian

word "Luce". To accentuate the reference to light, the project's theme, it was decided to represent the logo with the yellow color used in all the processors inherent to the project, the subject of the exam, graphically coordinating the entire project.

## Ergonomic studies

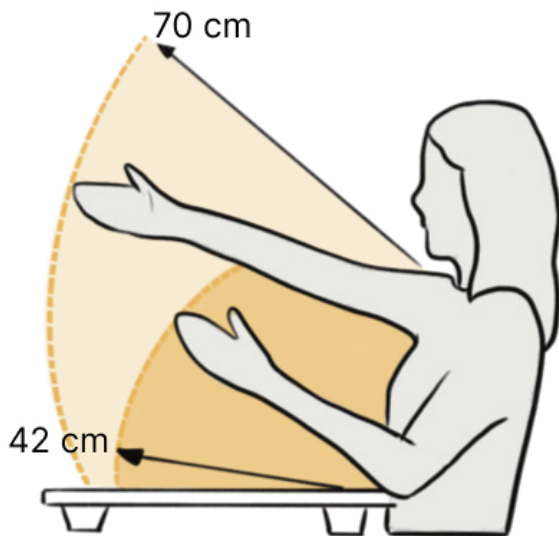

Before studying the different support bases, we started with ergonomic considerations relating to the standard work surface on a table. In this way it was helpful to understand the surface area to be illuminated, the correct positioning of the lamp and its dimensions. To do this, the range of a user's movements while performing a seated activity was analyzed. For the measurements of the movements, the average dimensions of a man and a woman were considered, from which it was obtained a work area of approximately 58-68 cm in length and 142 cm in width for the woman in the maximum field condition, i.e. with both arms outstretched, and 162 cm for the man. With the arms bent, i.e. in the case of an ideal grip field, the area concerned corresponds to 35-39 cm in length and 101 cm in width for women, while for men it is 109 cm. For the height of the lamp, it has been observed that the maximum length of an outstretched arm amounts to about 70 cm, a

value that the lamp should not exceed in order not to be uncomfortable in the grip. Although the studies were made considering a table position, the lighting values to be respected remains the same even if sitting on the sofa or on the bed, in order to make an optimal lighting of the same activity even if from different places.

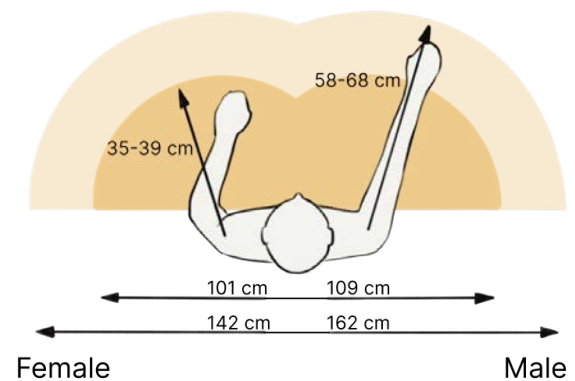

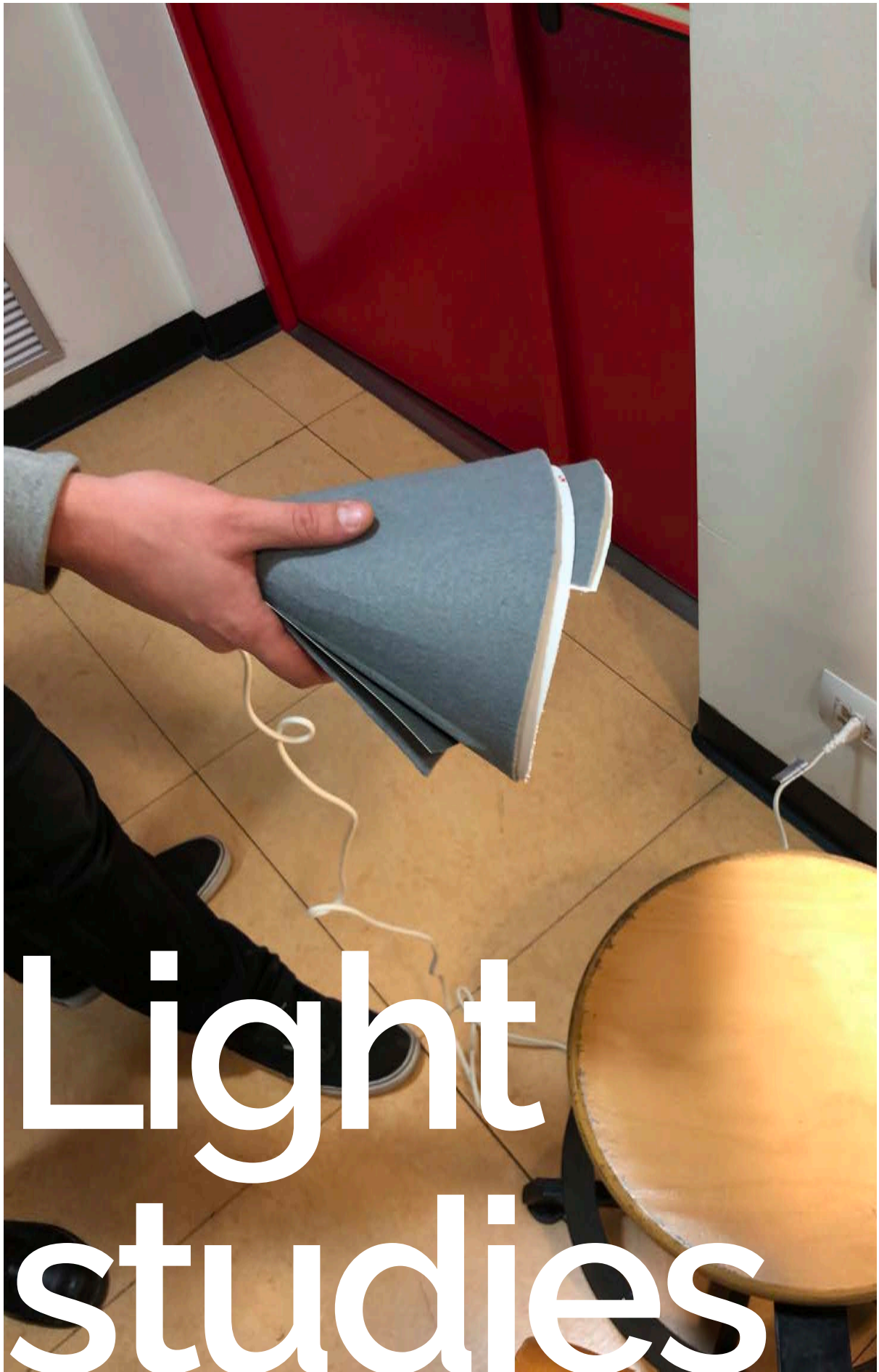

# Light studies

## Light features

# \* A light that helps to concentrate and to have energy

The study of light began following the definition of the activities performed by the personas. Since it is a lamp for study and work, similar researches were carried out on desk lamps, where attention was paid to the ideal light parameters foreseen for optimizing work. In fact, an essential element for desk lamps is the possibility of adjusting the light in terms of intensity, temperature and position. For this reason we have established a series of variable solutions for each of these parameters, which concern both structural and lighting aspects.



Parameters of a lamp are .The daylight spectrum, the temperature (kelvin) and that is the one that rotates the illuminance (lux). They between around 3000 and both have direct effects on 4000K, is considered ideal people's mental and physical for study and work, because health, significantly affecting of its neutral and white productivity and the mood. colour.

### LIGHT PARAMETERS

Among the most important

**1.**

***lampshade***

adjustable system  
diffuse to spot light

**2.**

***diffuser***

diffuser light used to  
avoid direct light

**3.**

***illuminance***

attention was paid to  
the correct lux

**4.**

***temperature***

dimmerable light with  
remote controller

For the subdivision of the activities, attention was paid to the tools used, such as the laptop, books and typical handcraft objects. The laptop, being a cold light source, needs lighting that compensates it. It justifies regardless of leisure or study, the ideal lighting parameters remain the same. For books, on the other hand, the exercise of the activity involves differences in the choice of light. In fact, free time reading requires a warmer and more relaxing light while in the moment of study it turns towards a colder one. Finally, handcraft, needs a colder light too to allow a correct view of details and small objects.



### **detailed work/handcraft**

*500 lx*

*3500k - 4000k*

---



### **studying on books/paper**

*500 lx*

*2700k - 3000k*

---



### **working/studying on laptop**

*500 lx*

*2700k - 3000k*

---



### **freetime reading**

*300 lx*

*2700k - 2800k*

---

## Case studies



After discussing with Professor Jaconussi, we researched some solutions on the best way to obtain effective light suitable for different activities.

It has been found that the ideal light is the diffused one, which happens when light hits the objects to be illuminated after a surface reflection. While analyzing the Luxo, in fact, it was observed how its direct light annoyed the eyes, which is why the user felt forced to rotate the lampshade towards the wall.



**Fresnel** Joe Colombo, 1966



**3d printed shades** Alessandro Zambelli, 2014

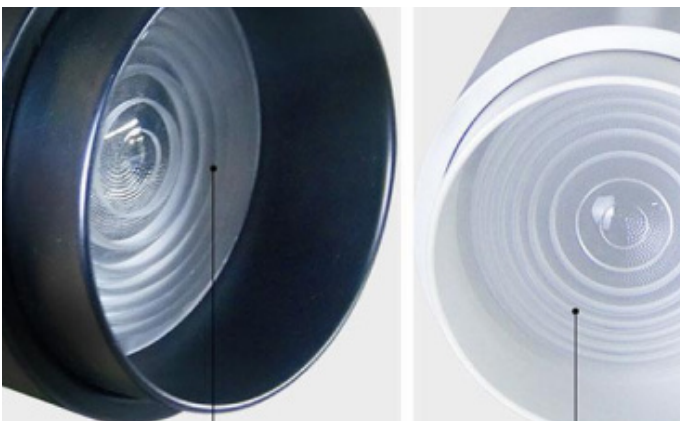

**Zoom lamp** Go Ocean, 2010

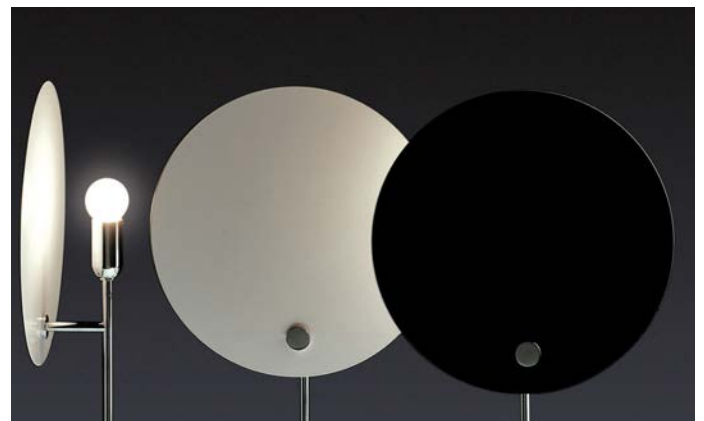

**Kuta lamp** Vico Magistretti, 1980

## Adjustable light beam system

### What is it?

The lampshade systemww consists of a rotating joint and a plastic made of PP, the plastic material is subjected to a uniform pressure across the joint and, by folding in on itself, the opening radius decreases and consequently the luminous amplitude. The choice of making an adjustable lampshade was born after some considerations on the lighting system of the Luxo lamp. In fact, with the Luxo, to better see a detail it was necessary to bring its lampshade closer to the object, and inevitably close to the head, interfering with the performance of the activity. The adjustable beam solution, on the

other hand, minimizes the movement of the structure and concentrates the lighting in a precise area, increasing the light refraction according to the width of the beam. With the adjustable beam, it is possible to meet the needs related to the different workstations and the level of disturb you want to create, especially if in the presence of other people. Furthermore, users often use a few devices at a time, such as a laptop or a book, and therefore it would not be necessary to waste energy to light up portions of space that are not really involved.

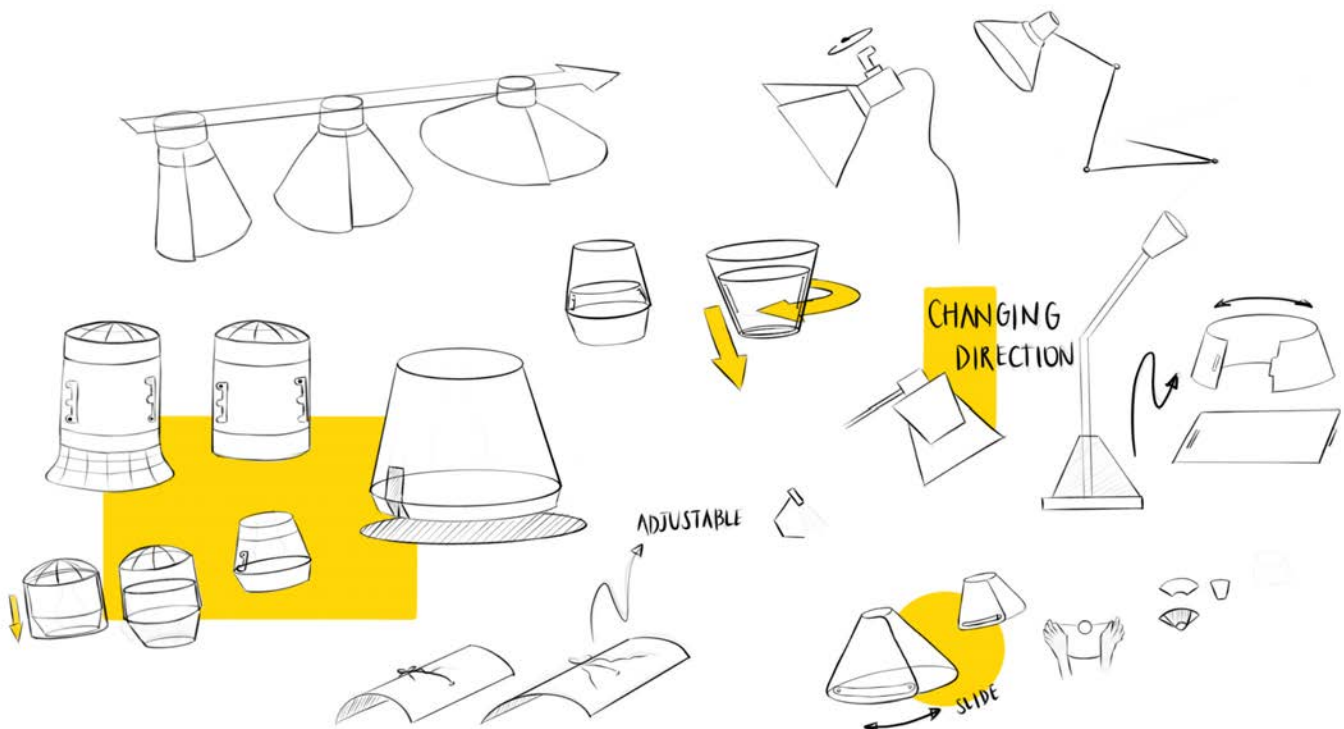



## Adjustable light beam system

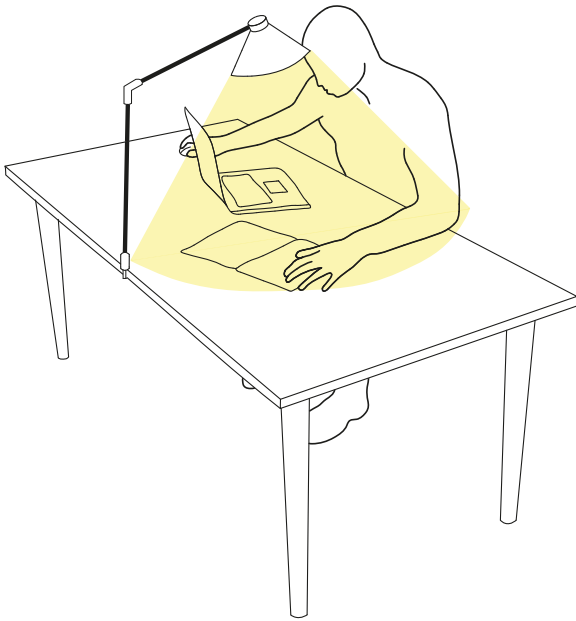

**105 cm**

diameter of the illuminated area at 60 cm from the work surface

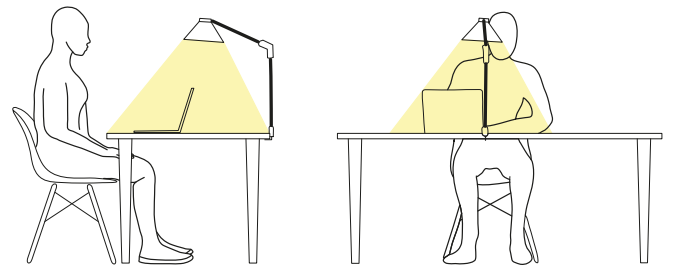

To establish the maximum width of the lightbeam, ergonomic studies on user movements were taken for references. In this way, it was easy to hypothesize an ideal height of the lamp that did not exceed 70 cm in order not to make its grip uncomfortable. The established value is in fact 60 cm, while the illuminated area on the surface at that distance corresponds to 105 cm.

This measure was decided considering the simultaneous use of multiple devices most used by the personas, that are a laptop and a book, or similar. To illuminate both, at least 90 cm is required, to which 15 cm have been added relating to the possible distance between the two.

# Final design



**Desk lamp with  
computer**





**Outer wire held  
with 3d printed  
clips**





Three different bases for each situation



Photo





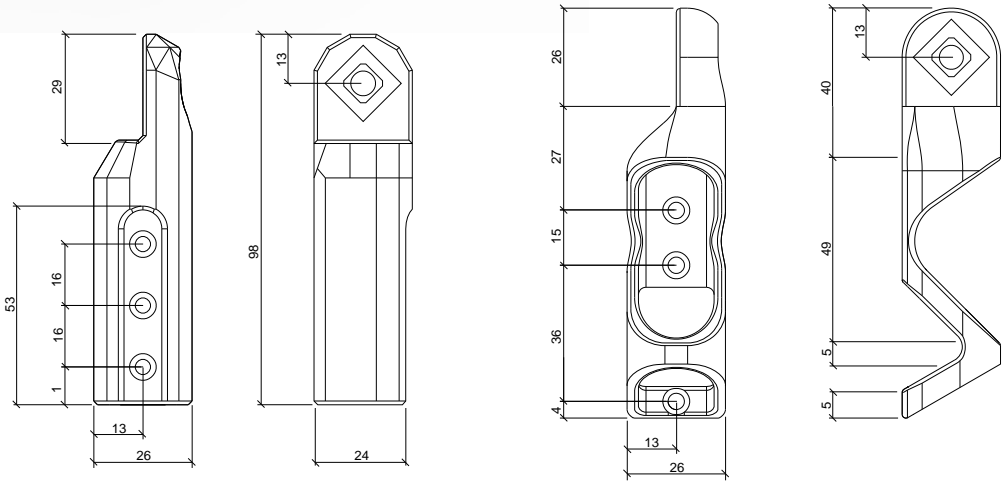
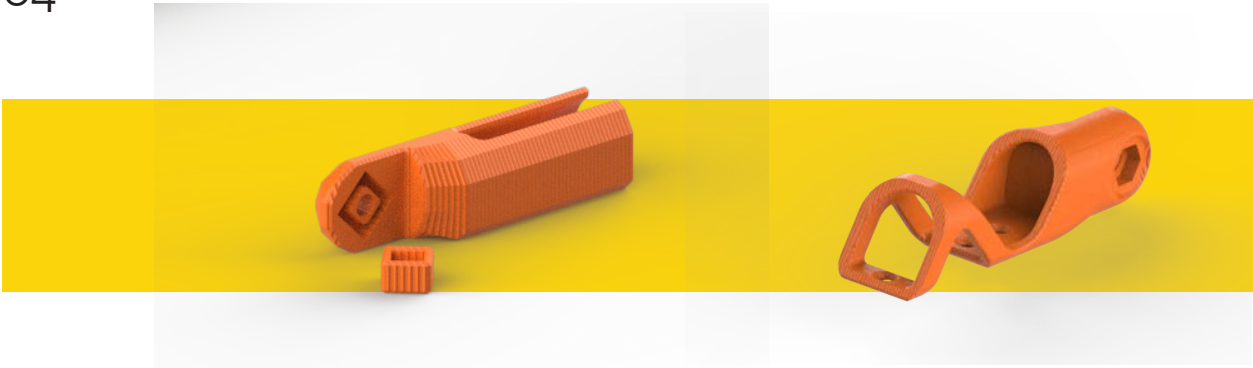

1:2 scale

Quote mm

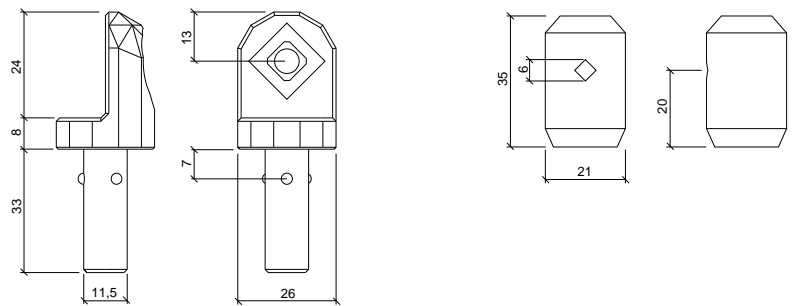
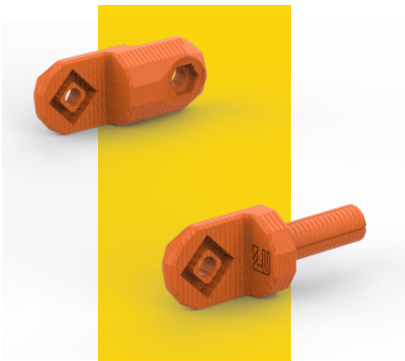

1:2 scale

Quote mm

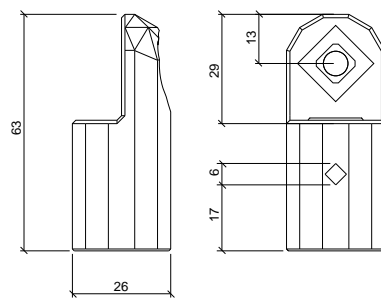



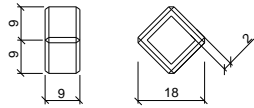
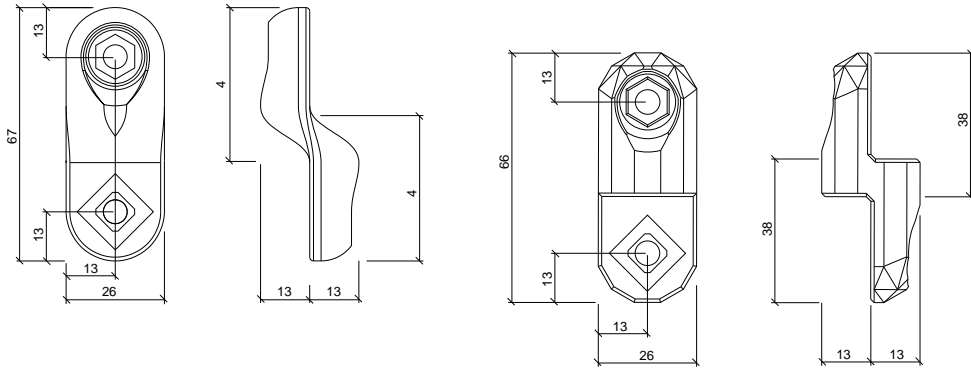

1:2 scale

Quote mm

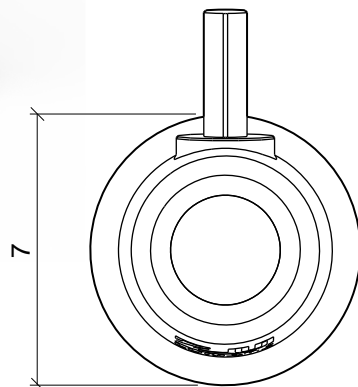
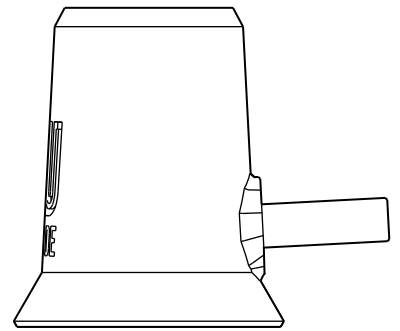
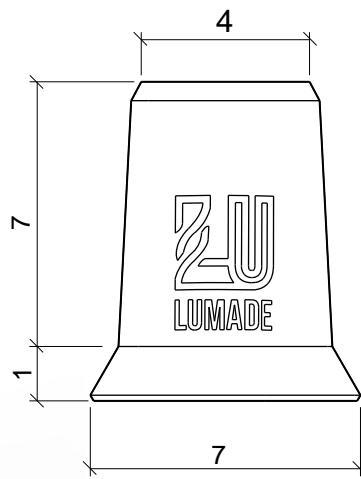

1:2 scale

Quote mm



Lampshade that  
opens and closes



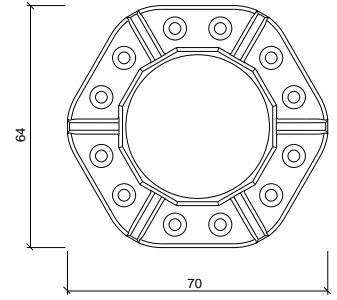
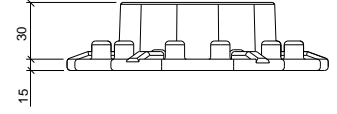
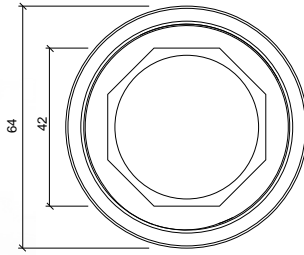
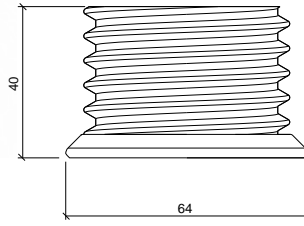
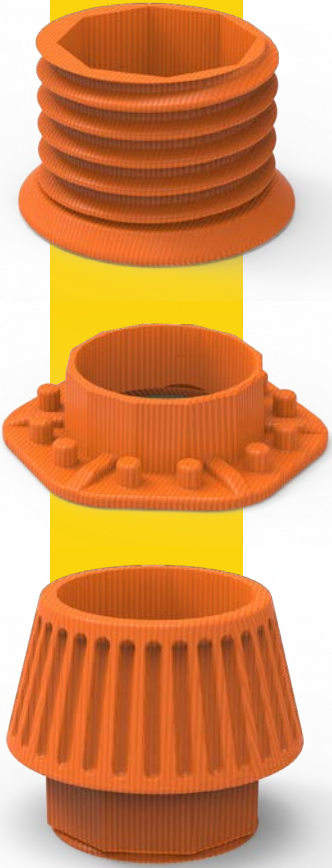

1:2 scale

Quote mm

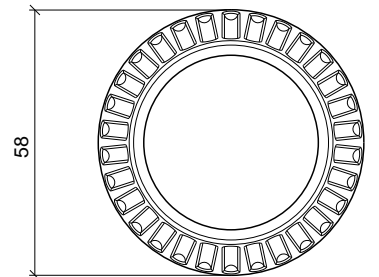
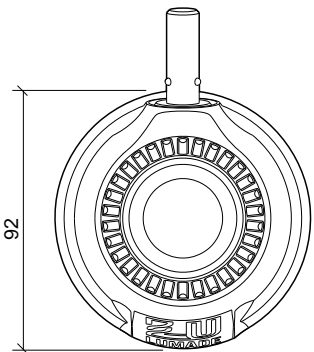
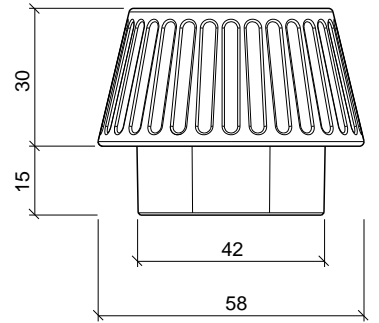
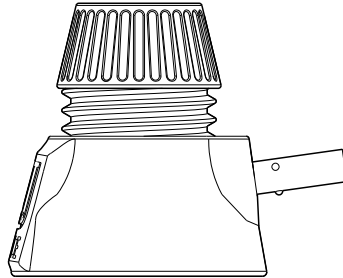
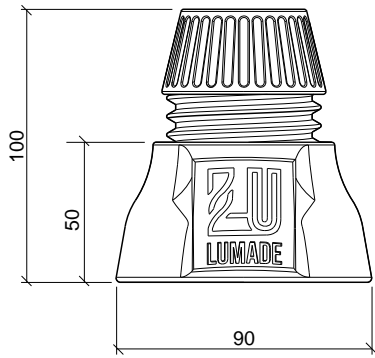

1:2 scale

Quote mm

1:1 scale

# Prototype



Having studied the different joining systems and their locking mechanisms we started working on the final joints. The technical solution employed is to use a rubber gasket held in place between two 3d printed parts by a bolt and a nut. The design constrains were that the printed parts must be connected on one end to the wooden staff and on the other end to one another and they are the bases and so they needed a flat face to allow wall and clamp mounting. While to allow the rotation in the other direction an inline joint that could be connected to the joints of the arm is needed.

## Pole connector

We started by defining a rough shape that could answer to these constrains and that allowed the pieces to connected with each other after printing [1]. This first solution worked but was too weak for the application and so e lengthened the surface of contact with the wooden staff and modified the screw holes needed for wall mounting so that they could be used to secure the staff in position [2].



[1] first version of connector



[1] first version of connector



[2] second version of connector

As for the connection between joints we decided to use an M6 oval head bolt and, after a suggestion by the group "Lumiere", a locknut. To reduce the complexity of the assembly the joint is symmetrical, this is achieved by having on the same face a recess to lock the nut in position and a larger flat face where the head of the bolt rests, by having this combination the bolt and nut is locked in position and only one of the joints can freely rotate.



[1] first version of connector

## Inline joint

The inline joint is needed between the joints that connect the staffs to enable a bigger degree of movement and to rotate the arms in the 3rd dimension. We started working on this piece thinking of using the inline rotating joints on all the connections of the lamp, and to keep the joints still the idea was to use an O-ring. One

the first iteration we were thinking of using two separate pieces connected with Chicago screws [3] , this was scrapped because the screws would need to be glued together to prevent them from unscrewing when operating the joint and because it increased the number of parts.

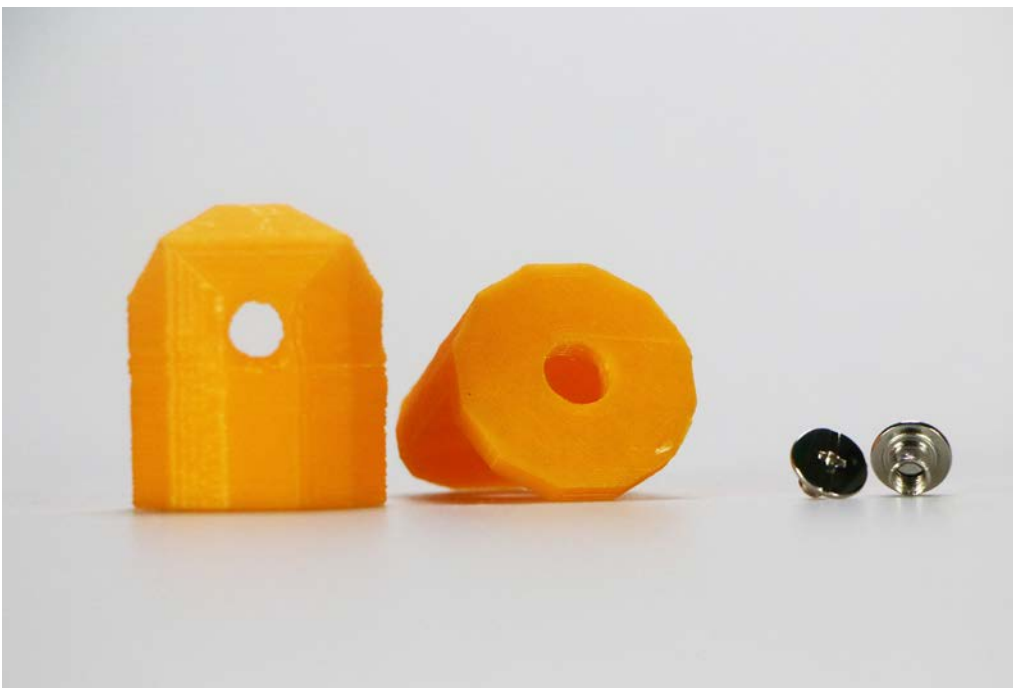

[3] chicago screws

After this we tried various 3d printed connections [4]:

Print in place, left behind because it required a carefully calibrated 3d printed and it made inserting the O-ring difficult [4.1].

Mortise and Tenon, abandoned because the pieces could separate during use and because it didn't put enough pressure on the O-ring [4.2].

Connecting pin, inspired by a design employed by Devin Montes, had problems with the distances required for the locking mechanism of the pin to work [4.3].

After testing all this iteration that had problems we went back to the drawing board and analyzed what was really needed for the lamp, by doing this we arrived at the conclusion that there was no reason to use the same rotating mechanism everywhere on the lamp, instead this had made things more complex, because the piece needed to be small to allow upper arms to be folded flat and this made the joint wobbly, which was a problem for the points where it was really needed, like in the base.

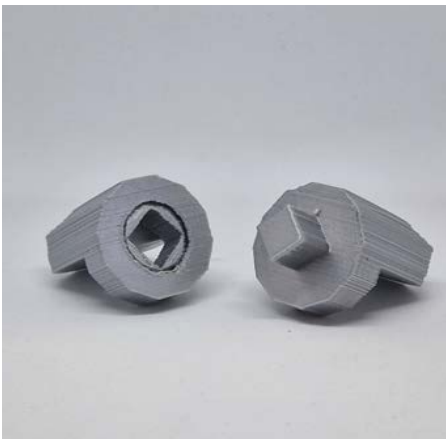

4.2 Mortise and Tenon joint



4.1 print in place joint



4.3 Connecting pin joint



4.2 Mortise and Tenon joint



4.1 print in place joint



4.3 Connecting pin joint

Having reached this conclusion we split the joint into 2 types, a fixed one that simply allows a bigger degree of movement on a plane and a revolving joint [5], which was made bigger to remove the wobbliness. The final revolving joint [6] is in two parts one with a print in place core that spins freely and one with a pin that can be connected to the core, while it is

held still by using a pin in the square hole, by using a bayonet mechanism with 3 dots, this mechanism was inspired by a mechanism done by the Angus Deveson, who used a similar one in a 3d model he designed.



6 bicchiere da caccia e pesca anonimo



5 bicchiere da caccia e pesca anonimo

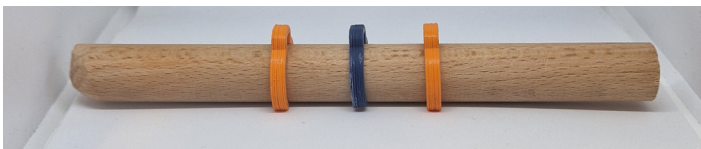

Clip for wire



Clip for wire

## The lampshade

For the lampshade we took inspiration from a collapsible cup for hunting and fishing [7] which is one of the anonymous objects possessed by Achille Castiglioni shown when you go and visit the Achille Castiglioni Foundation. This object is made up of 2 thin flat metal pieces connected together with 2 brass studs that allow the pieces to pivot and the cup to go from flat to open. From this we had the idea to use a thin plastic sheet folded on itself, we wanted to use the flexibility provided by the material to create the shape. From the start the idea was to allow the user to change the aperture of the lampshade, and so we designed with that in mind. The first iteration of the lampshade [8] was a 3-piece part which consisted of two parts that pressed on the plastic sheet and another that covered the lightbulb socket and allowed the connection to the rest of the lamp by using a bolt, after testing we discovered that having two parts pressing on the lampshade completely blocked the rotation. After this we thought of having a single pin to lock the sheet in position while still allowing its rotation, but with this system the only way of locking the aperture was to have a second locking point, this meant a separate piece that could be lost [9]. On the third iteration we tried a system that used two different points of connection which moved within a spiral guide, this resulted difficult to 3d print and needed that lampshade to be of an elastic material, since the



*7 bicchiere da caccia e pesca anonimo*



*8 3-piece lampshade*



*9 felt lampshade*





*10 lampshade with guide*



*11 lampshade with two pivot points*



*12 final lampshade*

distance between the two points kept changing [10]. All the designs up until this point used single part cut out from the sheet, but since they weren't working we decided to explore more complex solutions that utilized more than one sheet. We created a lampshade using two pieces of thin plastic and 2 3d printed parts that used a spiral or a tread to move between each other. The idea was to connect the two plastic sheets with pins that allowed pivoting and to change the position by moving the 3d printed parts, but this didn't work because if the pins were too tight they locked the position of the sheets too tightly restricting their movement, while if they didn't lock the position the elastic force wasn't enough to keep the lampshade open [11]. In the end we landed on a design that uses 6 smaller plastic flaps arranged on a hexagon on top of a 3d printed part that has pins to lock them in place. The movement is possible thanks to a screw thread which, by spinning, allows the core to move up and down and this makes the flap engage with another part that presses on them forcing them to fold [12].





## Open design

Open Design is a design approach that promotes open sharing and collaboration between designers, users, and other stakeholders in the creation of products and services. Through this model, ideas, data, and design processes are made accessible to everyone, allowing for greater participation and a wider diversity of contributions. The goal of Open Design is to create better, more innovative, and sustainable solutions by harnessing the power of the

community for value creation. This approach is based on the principles of openness, collaboration, and co-creation, and seeks to break down traditional barriers to participation in design. By making design more inclusive and democratized, Open Design aims to foster a more creative, innovative, and sustainable future for everyone.

## Open design

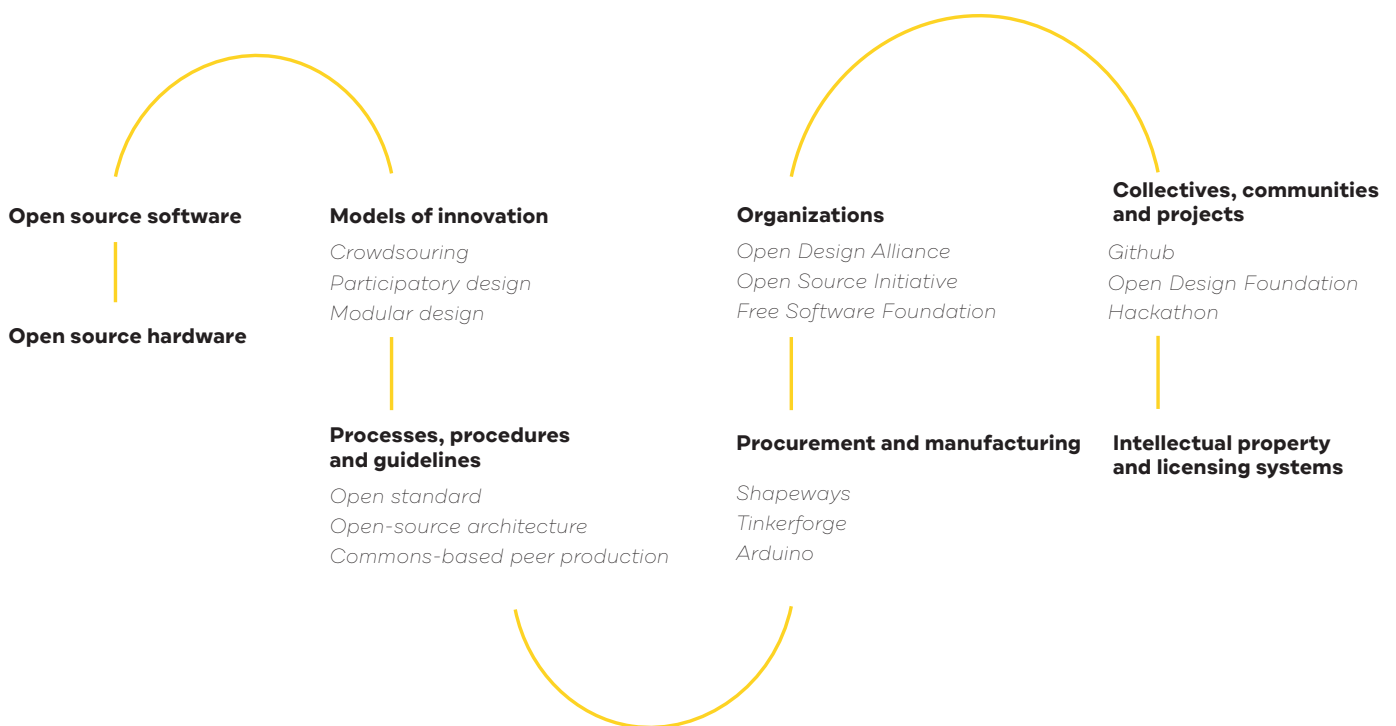

## Open source and course teams sharing

### October, 21th



**To use the same lamp for different desk activities**

#### why

to extend the use of the lamp to students and handcraft enthusiasts who use the laptop and other objects as a work tool

#### how

we used their suggestion when we made an openable lampshade. This made it possible to change the light beam from spot to diffused according to the user's tools and activity.

#### 1st team wheel

### November, 4th



**Focus the project on DIY**

#### why

they told us to pay more attention to the customization part and to the users who don't have a strong interest or experience in making the lamp

#### how

having two different types of realization of the lamp. The first is to build it from the beginning with cheaper pieces while the second is to assemble it by ordering the pieces from a website

### November, 4th

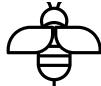

**Lamp simplification**

#### why

some of them suggested us to reduce the number of elements we wanted to include in our project, so to focus with more attention in the relevant aspects

#### how

we removed the "timer" part because it was too complicated and not effective. We kept the idea of making the lamp according to different levels of knowledge but avoiding the use of different technologies

### November, 18th



**Use different types of bases for a work lamp**

#### why

we want to use a desk lamp for different home workstations. Since not all of them require the same space obstacles, we considered to change the base position

#### how

use a modular joint for each bases that can be easily substitute according to the required needs.

## November, 25th



### User-lamp interaction

#### why

we were inspired by their illustrations of user interaction for the functions of our lamp. This helped us to consider better the mechanisms of movement

#### how

study of the different movements of the lamp in different places in the house. The attention was paid to make rotational and bendable joints. Also, the dimensions of the lamp have been outlined

### 2nd team wheel

## December, 16th



### Same joints used

#### why

since we have encountered similar structural problems we decided to use each others joints as variants in our projects.

#### how

we implemented same joints but with a circular rod instead of two rectangular rods. This means that the grip changes. We are also considering inserting a metal spring like they did, but we are not sure-

## December, 16th



### Aesthetics

#### why

since our components have a simple shape, they suggested us to emphasize the joints with colors that give prominence to the structure

#### how

we decided to use PLA joints with a bright color (like orange) and to include a configurator to help the user with color combinations and finishing suggestions

## December, 16th



### Joints

#### why

It is recommended by the group to use self-locking nuts to fix the joints and insert the bolts with the head recessed into the joint

#### how

We used the self-tapping nut on the joints of the structure

## **December, 16th**

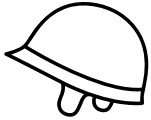

### **Sustainability**

#### **why**

lamp size depends on the length of the wood you find in the supermarket to optimize waste

#### **how**

the size of the lamp has been revised about the length of the rods present at the current, trying to optimize the waste of wood.

## **Legend**



**Five Guys**



**Lumiere**



**Bakery**

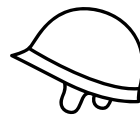

**Inglorious  
Designer**



**Pink  
Lantern**

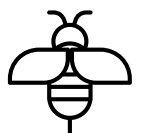

**Wannabee**

## Bilateral sharing with the Bakery Group

During the various talks we had with the other groups of the course we found out that our project and the one from the Bakery group had a lot in common. In the course only us and them designed a lamp which had two moving arms and used a system of joints to connect ready made wood sections to one another.

The major difference between the lamps are:

The shape of the wood sections, we created the lamp with circular wooden pieces in mind, while they used two flat rectangular wood pieces parallel to each other.

The locking mechanisms for the joints, while our lamp uses a friction based mechanism, they wanted to use a crown gear mechanism

The crown gear mechanism was an idea that we liked since the beginning of the project, but we discarded it because we wanted a mechanism that allowed the movement of the lamp without having to move the joints. This resulted in a mechanism where the gears were kept still by a spring with a specific tension to allow movement without having to disengage the gear teeth manually, but this meant the final user would need to acquire a spring with a very

specific elastic tension.

The mechanism that the Bakery group wanted to create is used with two hands, a spring locks the joint in place, to move the spring must be manually compressed. Having reached the conclusion that we could empower our projects by making them more varied and complete we offered a hand while they were designing their joint and we exchanged the mechanism between the groups so that ours could be used in their lamp and theirs could be used in ours.

The joint of the "FARO" project/lamp? Is under the Creative Commons Attribution-ShareAlike 4.0 International License license



# Open source project

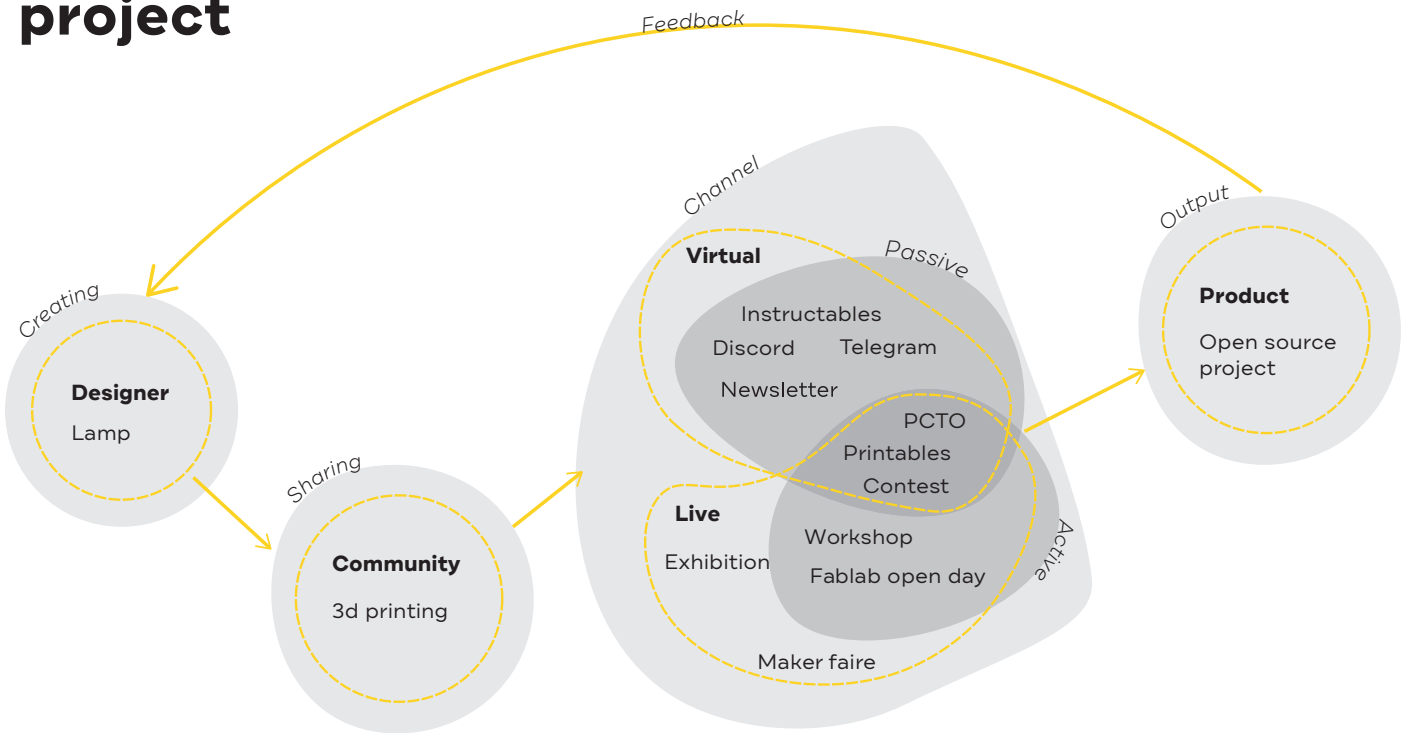

## Workshop: “open your mind”

The workshop will be organized through the PCTO (Transversal Competences and Orientation Paths), thanks to which Torino FabLab will participate and involve the students, introducing them to the world of work. The goal of the course is to provide knowledge of open design and 3D printing, promoting and conveying an idea of innovation that is always social, and not speculation on the ignorance of others.

The workshop will start with lessons on 3D printing and open design. Later, the students will be divided into 4 groups: one will take

care of sustainability, one the joints, one the lampshades and other one the base. All teams will work in different times on a map called “navigation map” to complete a project that requires the contribution of all participants in the spirit of open design. The next step will be to create and print in 3D the lamp, the result of the students' work, one for each member of the group.



### Age

Students between 17 - 19



### Where

Fablabspace



# Target

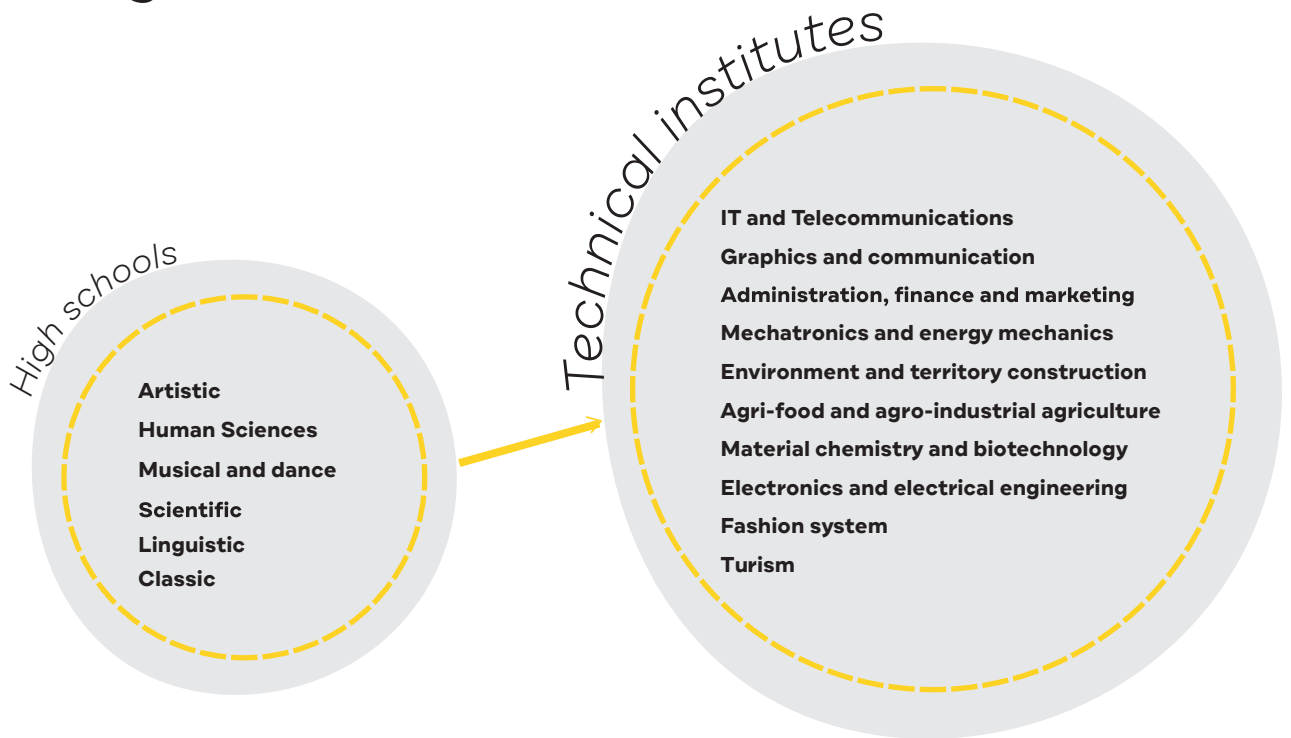

## PCTO

Pathways for transversal skills and orientation (PCTO) are curricular projects, which allow students to integrate traditional classroom training with training periods in companies or private or public bodies with special agreements, but also in school laboratories or in simulation environments.



### How much time

90 h  
high school

150 h  
technical institutes



### Age

Students between 17 - 19



### When

during the three years of high school



### Where

Fablabspace



# Organization

The Open Design workshop offers high school students the opportunity to participate in a unique design and collaboration experience. Participants will be divided into groups to tackle four design phases: joint creation, shade creation, sustainability, and concept ideation.

3D printing will provide an opportunity to experiment with printing technology and see how the project takes shape.

During the workshop, each group will have the opportunity to correct and modify the ideas of other groups, leading to the construction of a 3D printed lamp. The focus on sustainable design will help participants understand the importance of sustainable design and incorporate these principles into their design.

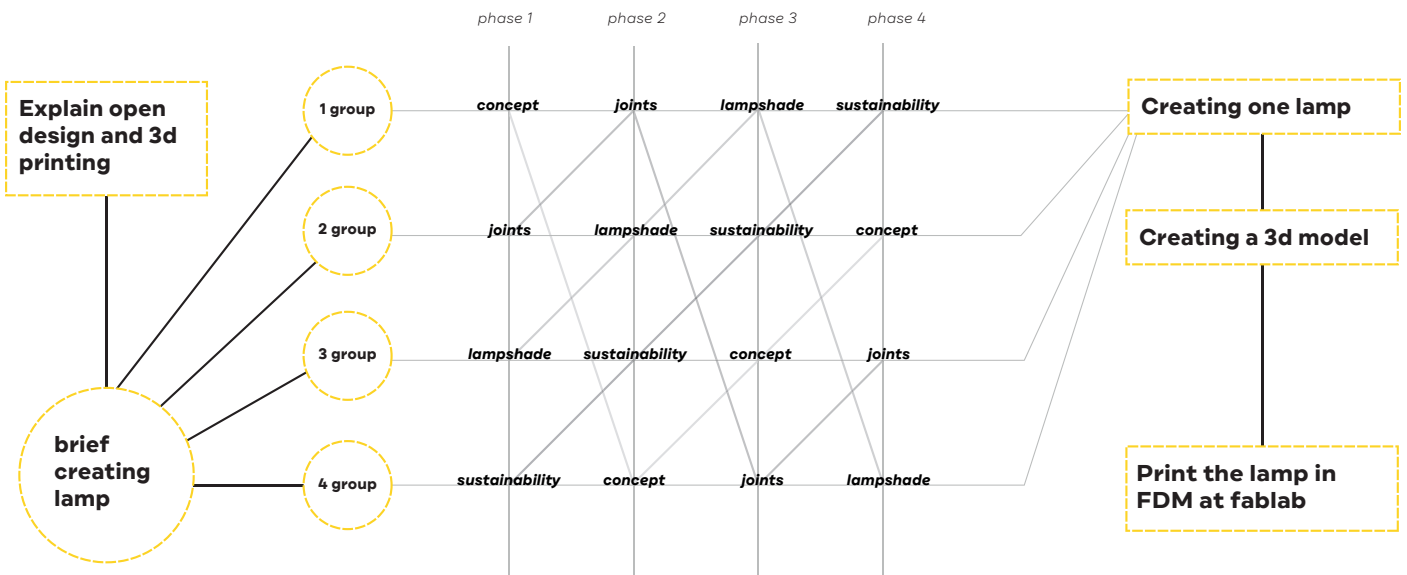

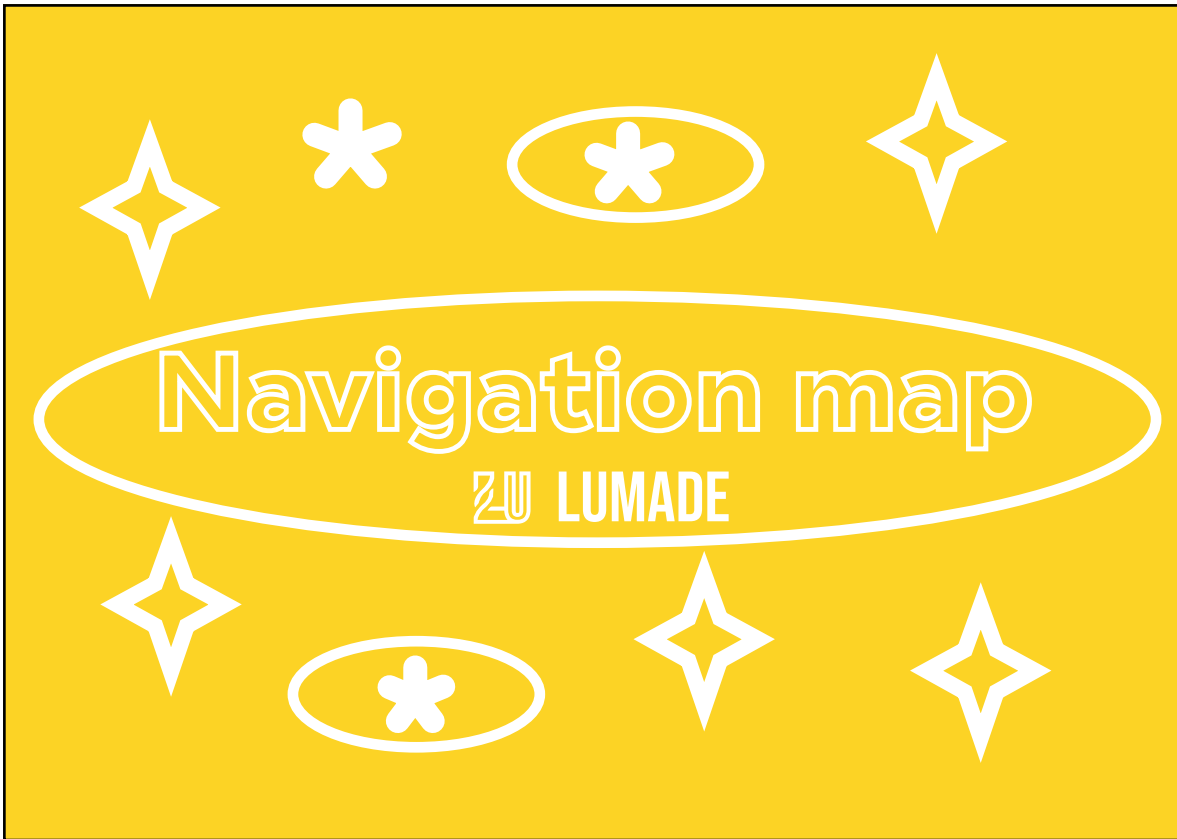

<p>Sketch</p>	<p>PRO</p> <p>cons</p>
<p>Brief</p> <p>The idea of the navigation chart is to keep track of the design outputs that emerged during the group discussion. We start by filling in the name of your group, then you draw the sketches of the ideas you have thought of and analyze the pros and cons of your idea by drawing final conclusions. The idea is to leave the next group a base from which to start to continue the project</p>	<p>✏️</p> <p>+</p>
<p>Name</p> <p>_____</p> <p>✿</p>	<p>Final consideration</p> <p>_____</p> <p>Implement for next group</p> <p>_____</p>

## Next step

Furthermore, at a later stage, it would be possible to extend the initiative to middle school children. PCTOs are just a starting point

The project plans to introduce open design also at the basic school level, so as to direct children in the development of creative and investigative thinking. To achieve these objectives, it is necessary to extend the idea of the workshop to different schools of order and grade. The workshop has to change its shape slightly, to adapt to the skills of the younger students, introducing constructive metaphors such as the use of cardboard and clay.

Carrying open design means creating multiple possibilities, which can be both influential and methodological in the lives of the users. We hope that embracing this concept in education systems will transform the minds of an entire generation.

Below you can see an example of a workshop for middle schools

The workshop is aimed at middle schools and focuses on open design and 3D printing. It will start with an introductory lecture on the concepts of open design and 3D printing.



### Age

Students between 11 - 14



### Where

Hybrid Fablabospace  
Informatic laboratory school

Then, the class will be divided into two groups: one group will use clay to create the base and joints of the lamp, while the other group will use cardboard to make the stems and shade.

Once these components are created, the children will model the lamp on a computer and, once the renderings are obtained, they will print it in 3D at the fablab. The use of clay and cardboard is intended to represent a metaphor for a world in which 3D printing and additive manufacturing are guided by a philosophy of reducing waste for the benefit of the planet.

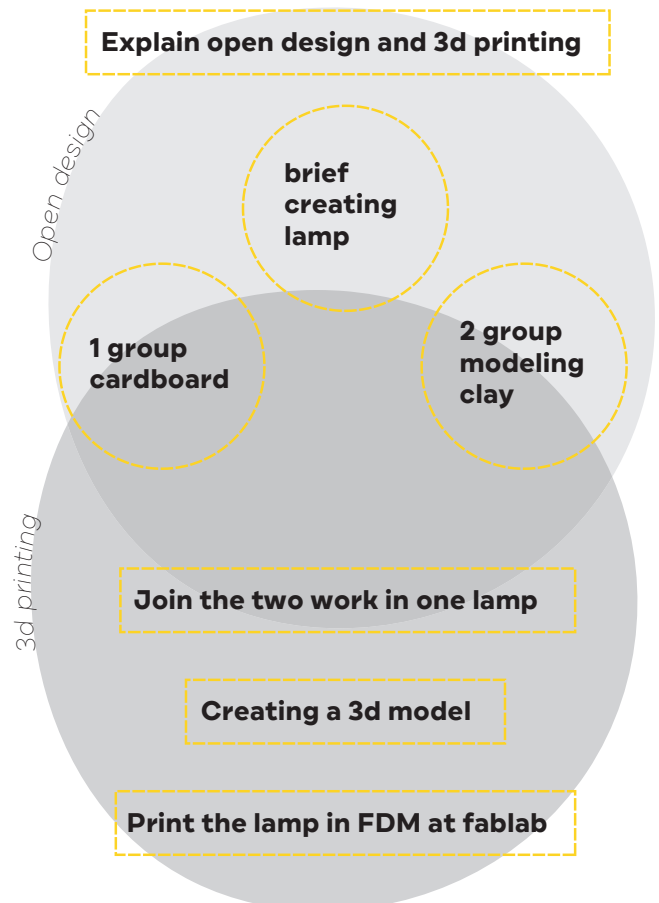

## License of use

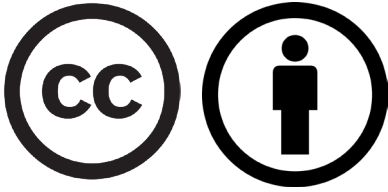

### Attribution 4.0 International (CC BY 4.0)

This license allows everyone to share, copy and redistribute the Lumade project in any medium or format and to adapt, remix, transform and build upon the original project for every purpose, even commercially. What is needed is only the attribution. With this license everyone who works or uses our project needs to give us the credit for the original work, they must provide a link to the license and indicate if changes were made.

