

REVISIONS			
SYM	DESCRIPTION	DATE	
A	ORIGINAL	5/20/09	BJD

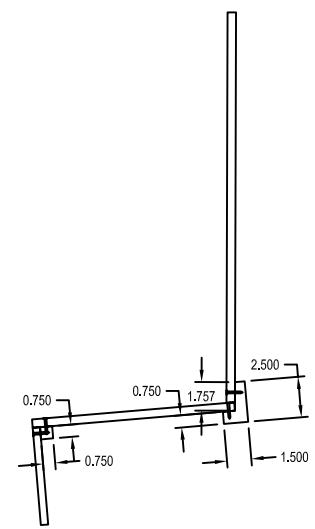
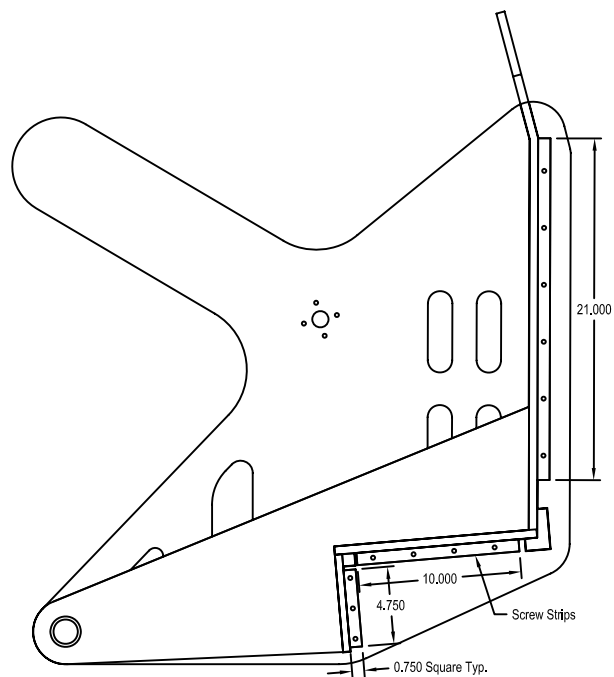
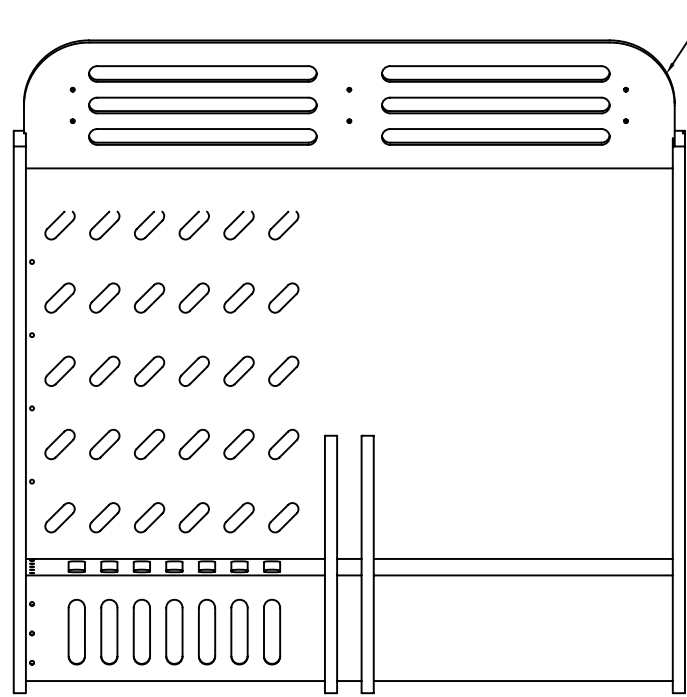
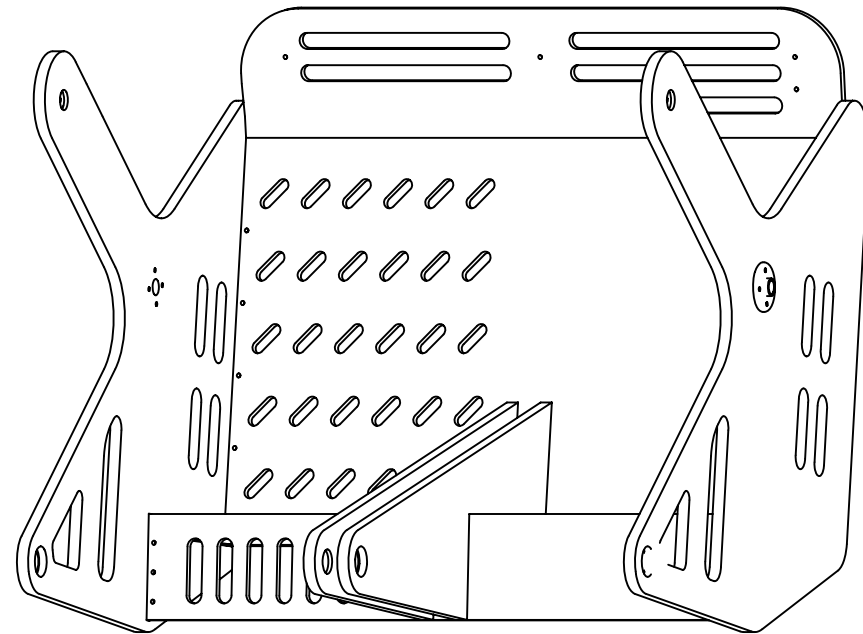

Seat assembly view

DRAWN	BJD	5/20/09	Chassis Assembly	Dring Engineering Services
CHECKER				
MECH. ENGR.				
ELEC. ENGR.				
PROJ. ENGR.				
CHIEF ENGR.				
SCALE				Chassis
				SHEET 1 OF 1

REVISIONS			
SYM	DESCRIPTION	DATE	
A	ORIGINAL	BJD 5/20/09	

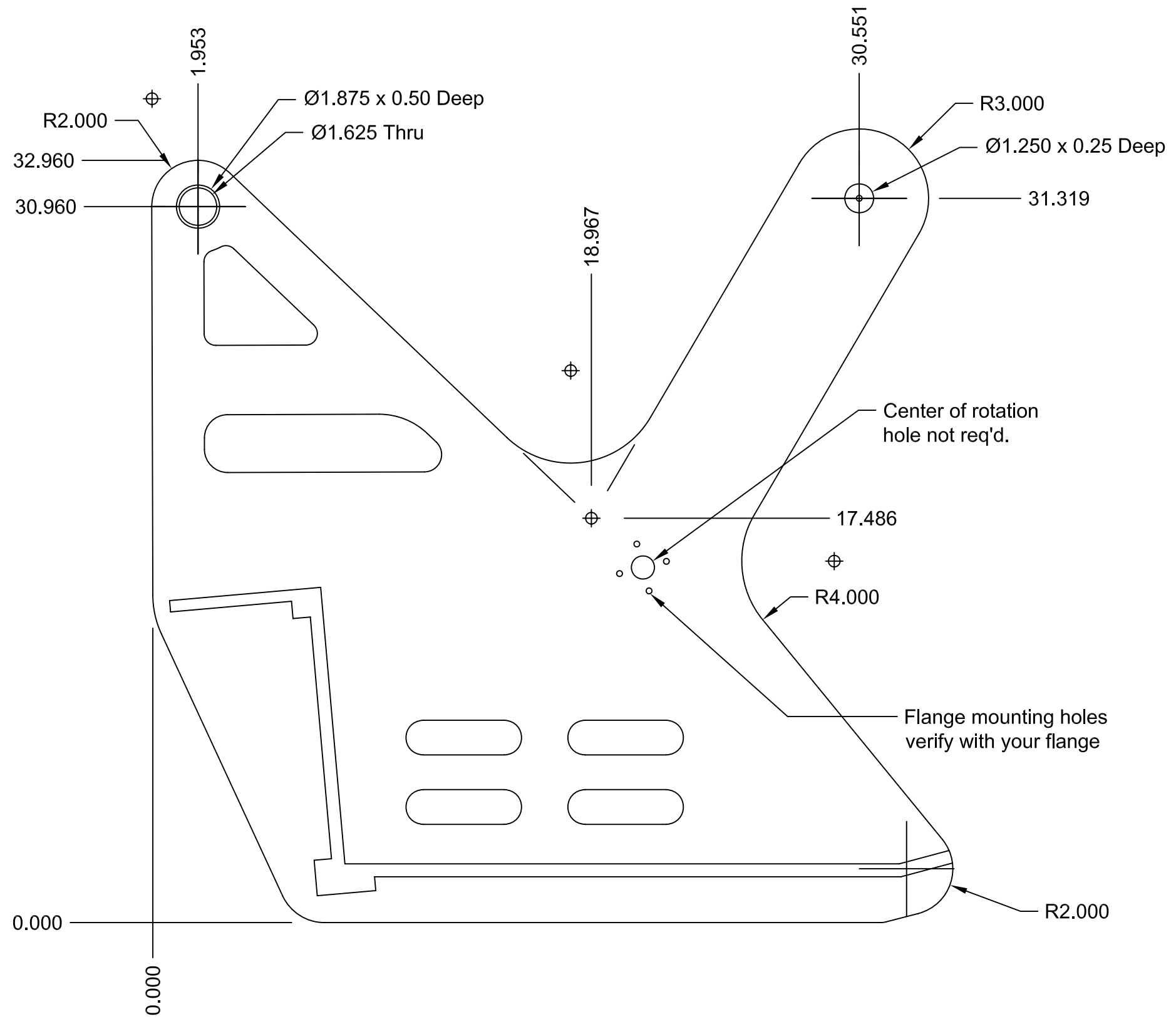

Material: 3/4" Plywood
 2 Required.
 If plywood has different finish qualities on each side make 2nd one a mirror image

DRAWN	BJD	5/20/09	Chassis Side Wall	Dring Engineering Services
CHECKER				
MECH. ENGR.				
ELEC. ENGR.				
PROJ. ENGR.				
CHIEF ENGR.			Chas_Side	
SCALE				SHEET 1 OF 1

REVISIONS			
SYM	DESCRIPTION	DATE	
A	ORIGINAL	BJD 5/20/09	

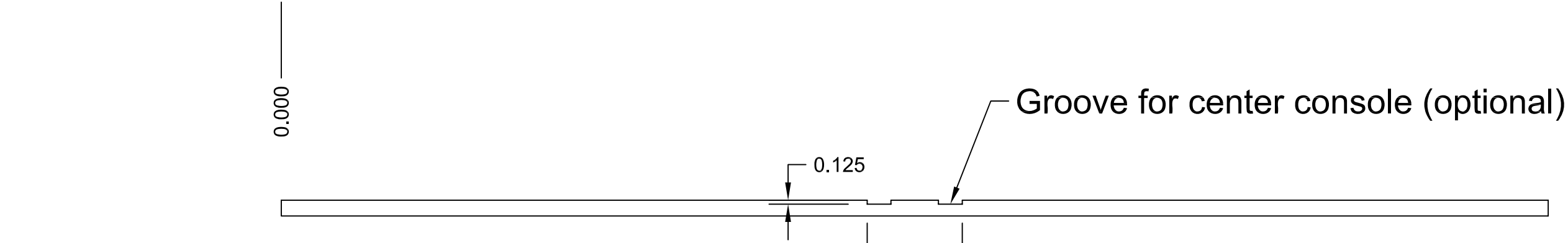
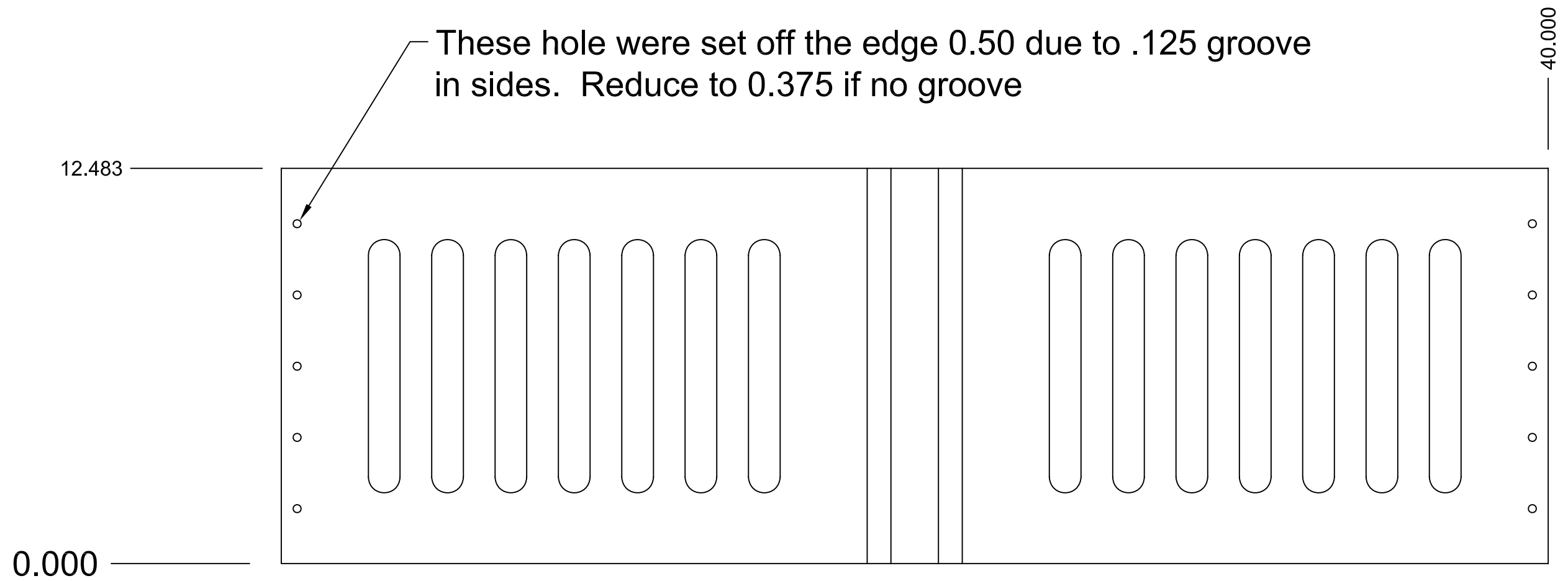

Material: 1/2 Thk Plywood.
Good Side Up

DRAWN	BJD	5/20/09	Chassis Seat Bottom	Dring Engineering Services
CHECKER				
MECH. ENGR.				
ELEC. ENGR.				
PROJ. ENGR.				
CHIEF ENGR.				
SCALE				Seat
				SHEET 1 OF 1

REVISIONS			
SYM	DESCRIPTION	DATE	
A	ORIGINAL	BJD	5/20/09

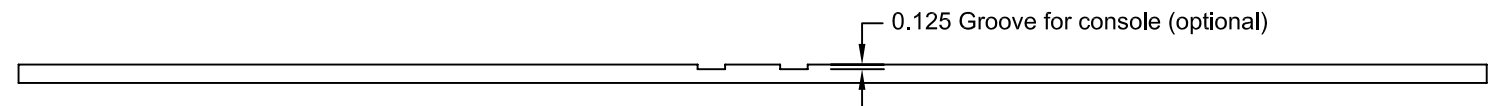
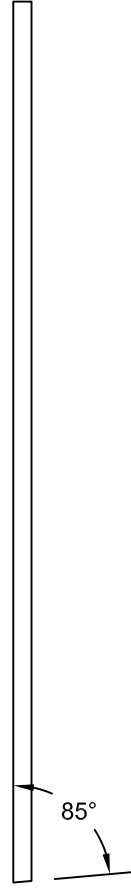
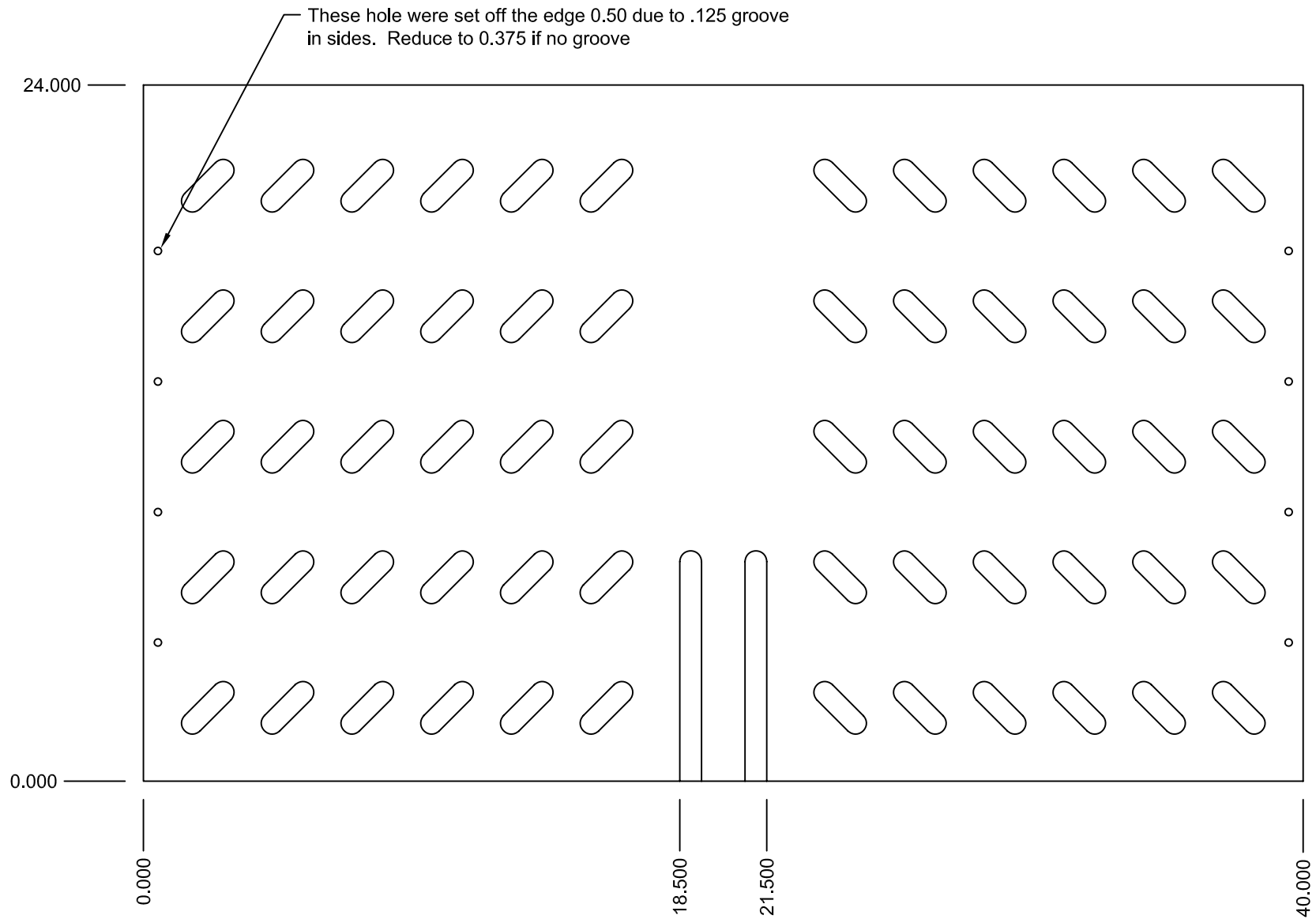

DRAWN	BJD	5/20/09	Chassis Seat Back	Dring Engineering Services
CHECKER				
MECH. ENGR.				
ELEC. ENGR.				
PROJ. ENGR.				
CHIEF ENGR.				
SCALE				Seat_Back
			SHEET 1 OF 1	

REVISIONS			
SYM	DESCRIPTION	DATE	
A	ORIGINAL	BJD 5/20/09	

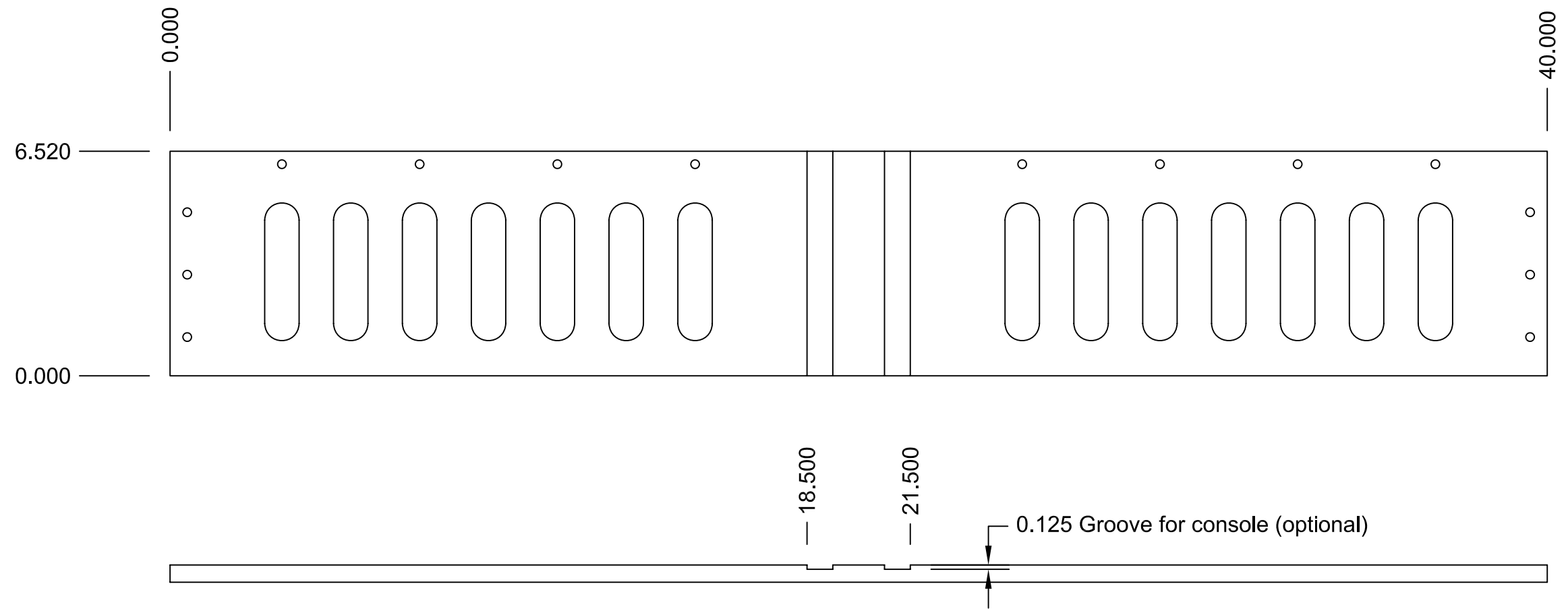

DRAWN	BJD	5/20/09	Chassis Seat Base	Dring Engineering Services
CHECKER				
MECH. ENGR.				
ELEC. ENGR.				
PROJ. ENGR.				
CHIEF ENGR.			SCALE	Seat
				SHEET 1 OF 1

REVISIONS			
SYM	DESCRIPTION	DATE	
A	ORIGINAL	BJD	5/20/09

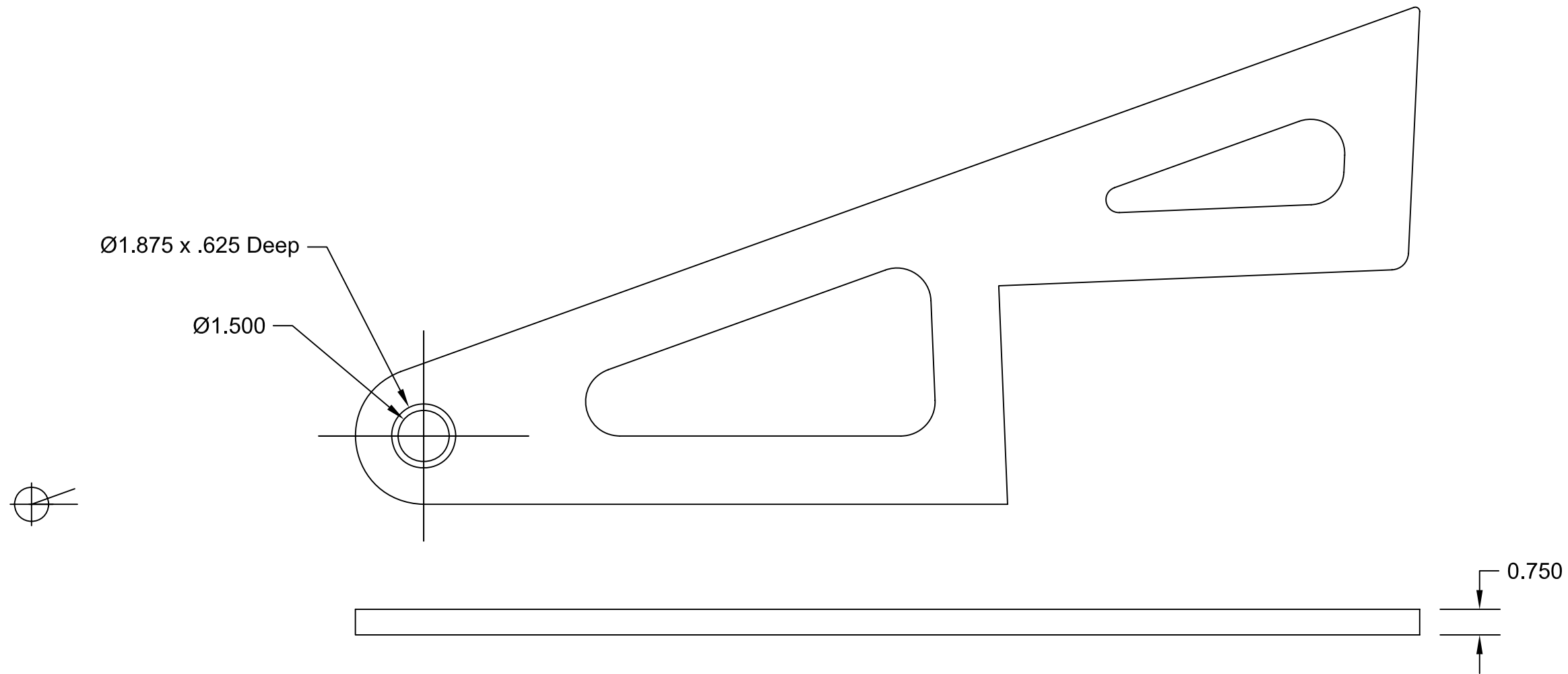

This version is sized for seat with groove cut for this piece. Adjust dims if you do not use a groove.

DRAWN	BJD	5/20/09	Seat Console	Dring Engineering Services
CHECKER				
MECH. ENGR.				
ELEC. ENGR.				
PROJ. ENGR.				
CHIEF ENGR.			SCALE	SEAT_CONSOLE

REVISIONS			
SYM	DESCRIPTION	DATE	
A	ORIGINAL	BJD	5/20/09

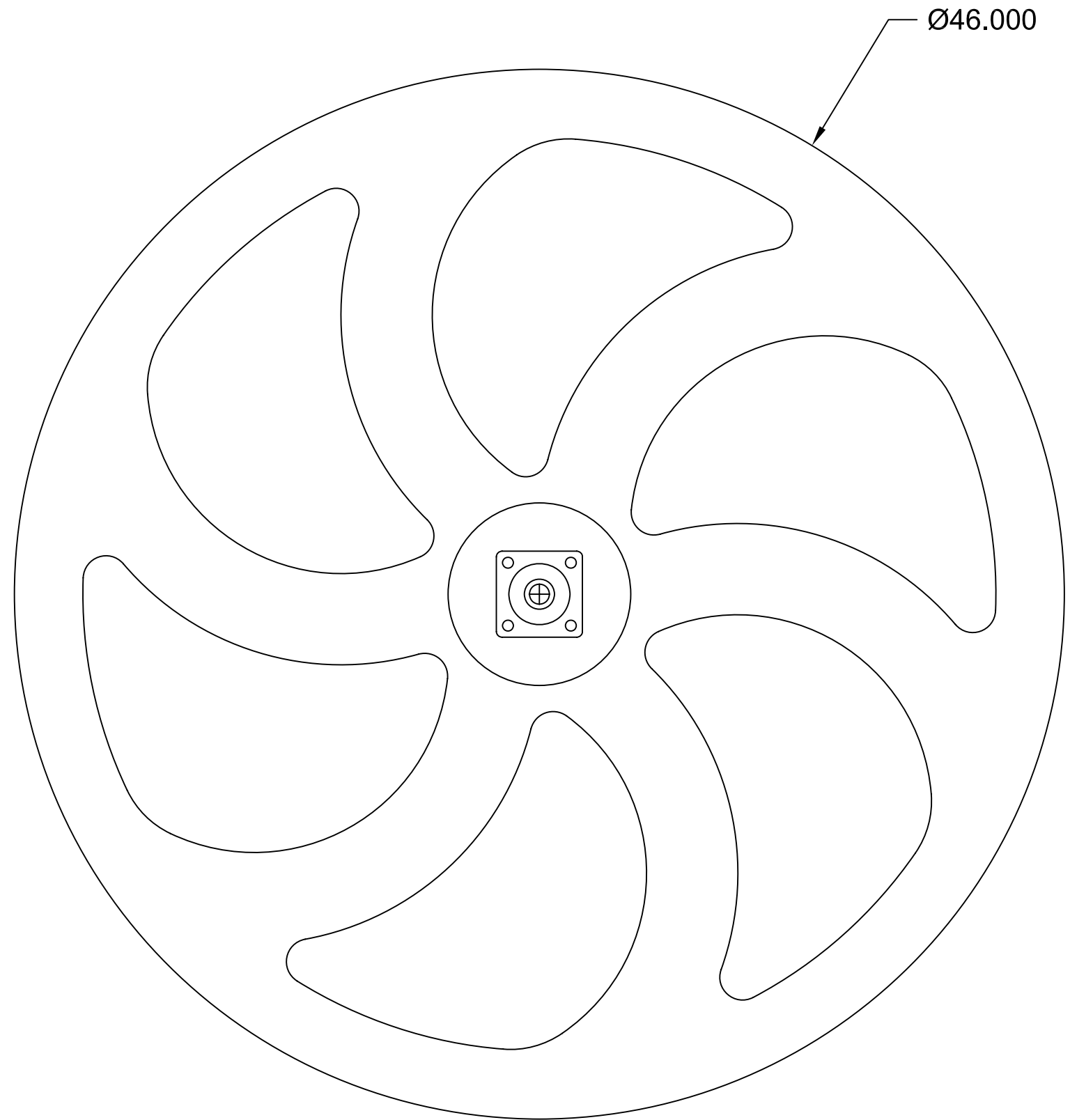

DRAWN	BJD	5/20/09	Wheel	Dring Engineering Services	
CHECKER					Wheel
MECH. ENGR.					
ELEC. ENGR.					
PROJ. ENGR.					
CHIEF ENGR.					
SCALE				SHEET 1 of 1	