

Valve Lifter Assembly (16x)

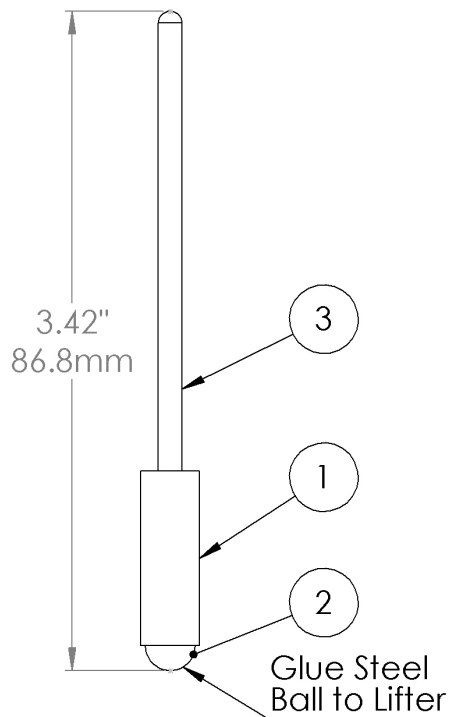

If assembled length is too long or short, scale lifter in the Z axis and reprint.

ITEM NO.	PART NUMBER	QTY.
1	Lifter	1
2	.25 Steel Ball Bearing	1
3	Push Rod	1

Valve Assembly

Intake (8x)
Exhaust (8x)

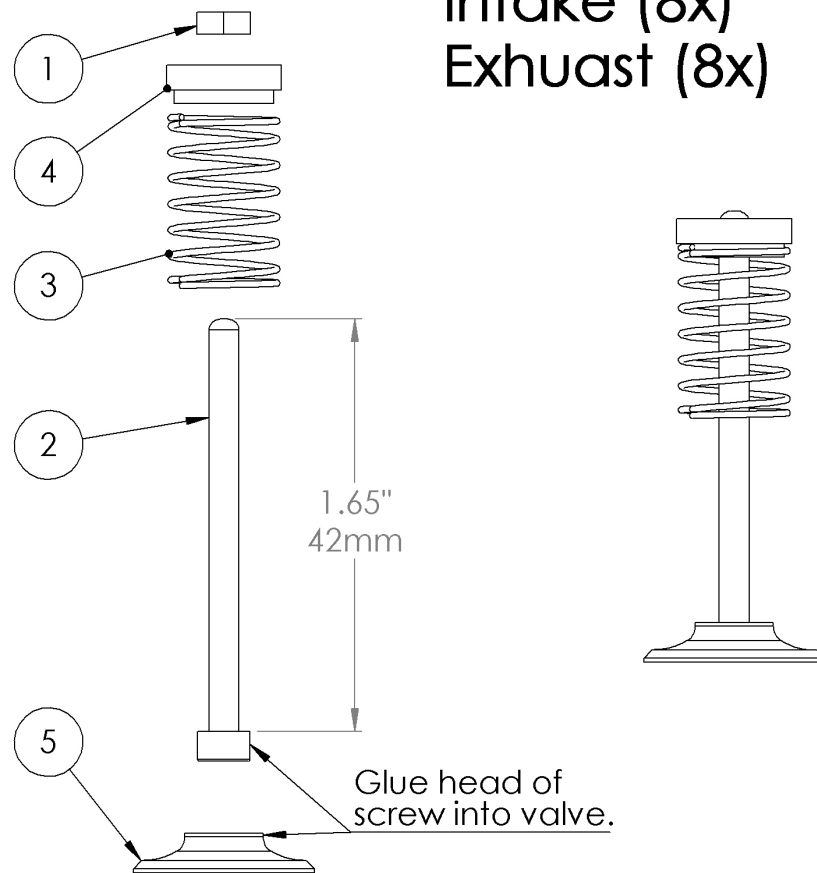

ITEM NO.	PART NUMBER	QTY.
1	m3 nut	1
2	M3 42mm SHCS (cut down from M3 x 50mm SHCS)	1
3	Valve Spring	1
4	Spring Retainer	1
5	Intake Valve	1