

5cm milling vise

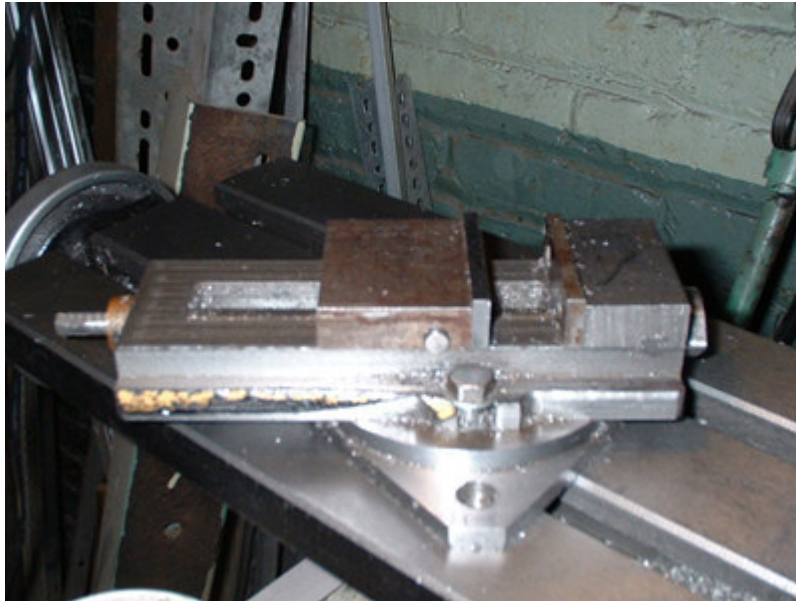

The vise is based on a popular style of vise manufactured by Kurt, but scaled smaller and around a few handy pieces of scrap and an odd tap.

The body is a strut cut out of the iron frame from a junk George Bent "Crown" upright piano, but the jaws and nut are some steel cutoffs. The 3/8"-20 lh screw is a nice fit between the 16mm shoulder and 1/4" hex drive, and it is supported between two thrust bearings.

The fixed jaw is held in place with a 1/4" square key and two 1/4"-20 shcs. To make advantage of the screw body, and even more so to assure location I drilled undersize pilot holes in the vise body and then in assembly drilled with a nr. 8 drill though both parts, following with an F and tap.

The movable jaw is one piece but the rear portion might as well be pinned and screwed on to simplify milling the recess. The nut is made to fit the lower channel and jaw recess, and drilled clamped in place at the same time as the clamping screw hole with a long drill. Instead of a fiddly loose pad the cylindrical insert is just a 1/4" dowel pin with a ground flat, lightly pressed in place so it can self align with the face on the nut.

I used a piece of 1/2" rod for the screw, and pressed a 5/8" collar onto the end to bear against the thrust washer. The cast iron washer is press fit into the housing with some grease and the screw, holes for the 2-56 shcs drilled in assembly like with the fixed jaw.

The base is sawn out of a plate that already had the stepped bore, and the ears shortened on a lathe faceplate to clear hex bolt heads. The clamping plate is cut off the end of a shaft coupling turned down to fit the recess. Slots for alignment keys would complete the vise and base but I haven't made them yet.

Clark Panaccione
<http://www.freewebs.com/mireut/>
13.02.05

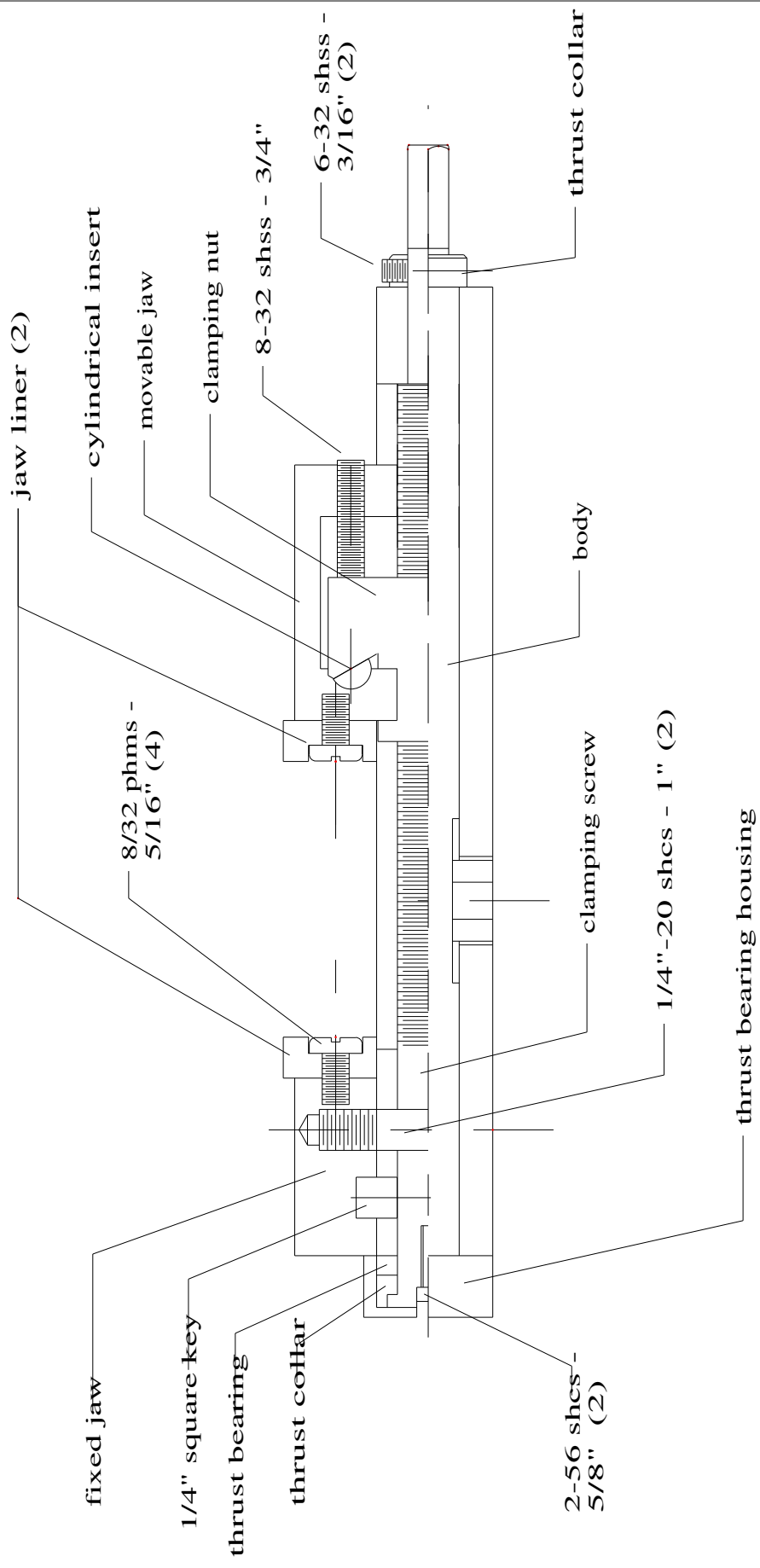

5cm vise

Assembly

14.11.04

1:1

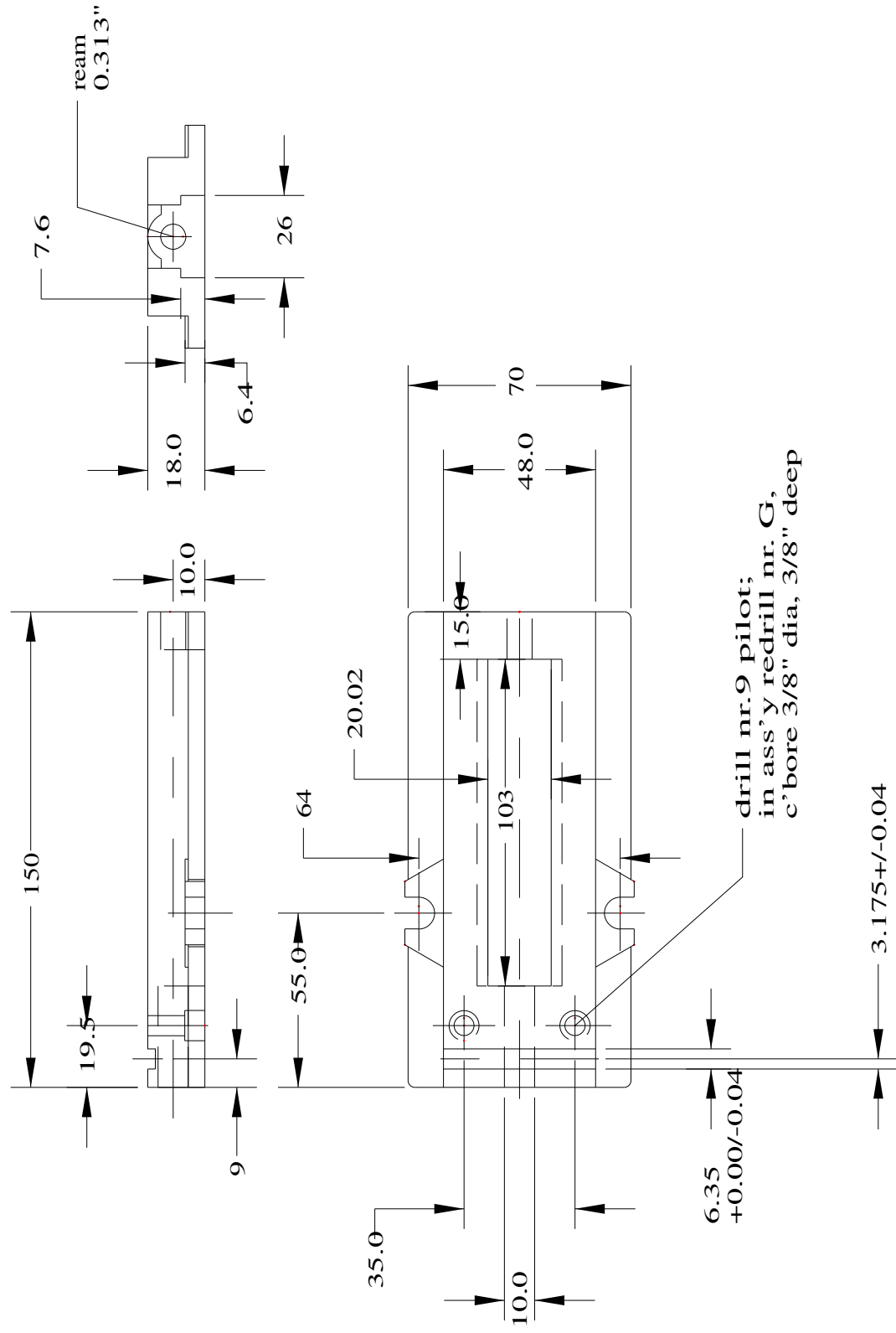

5cm vise

base

14.11.04

1:2

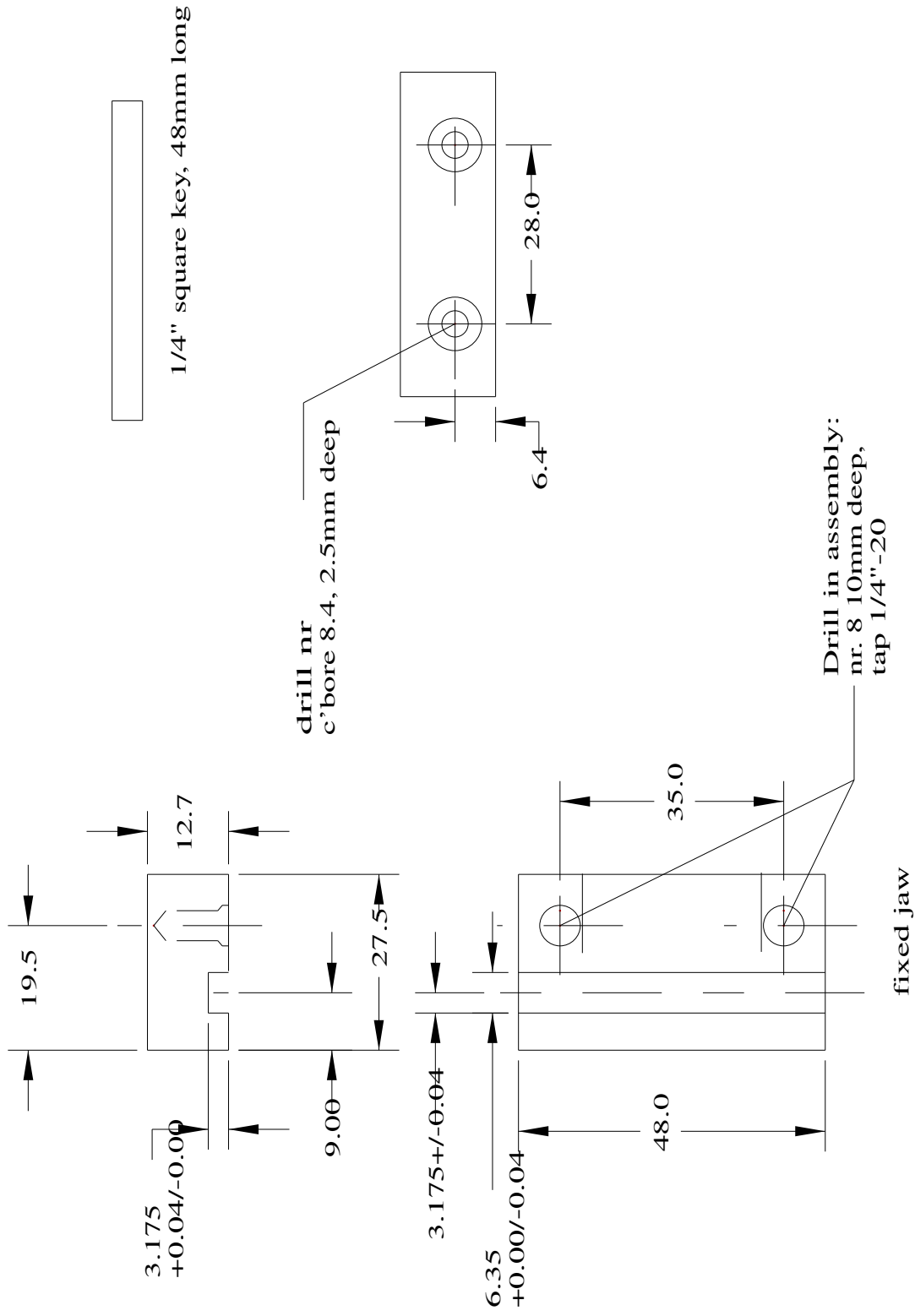

5cm vise

fixed jaw

16.11.04

1:1

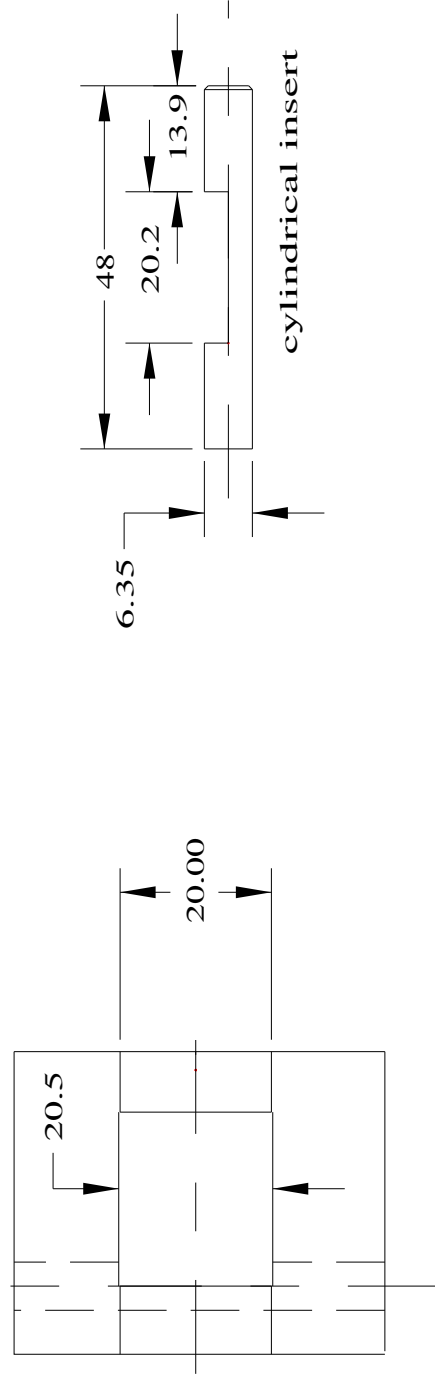
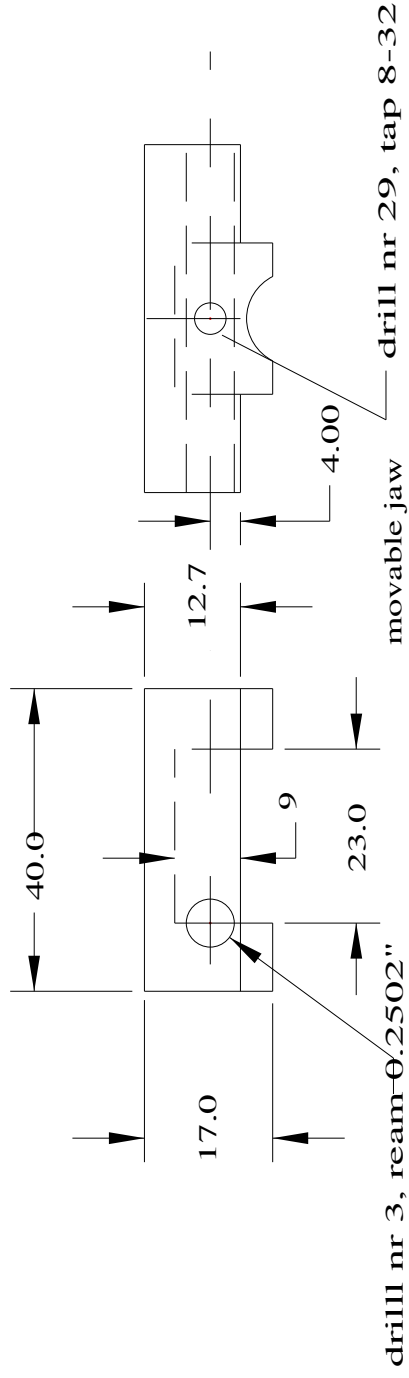

5cm vise

moveable jaw

14.11.04

1:1

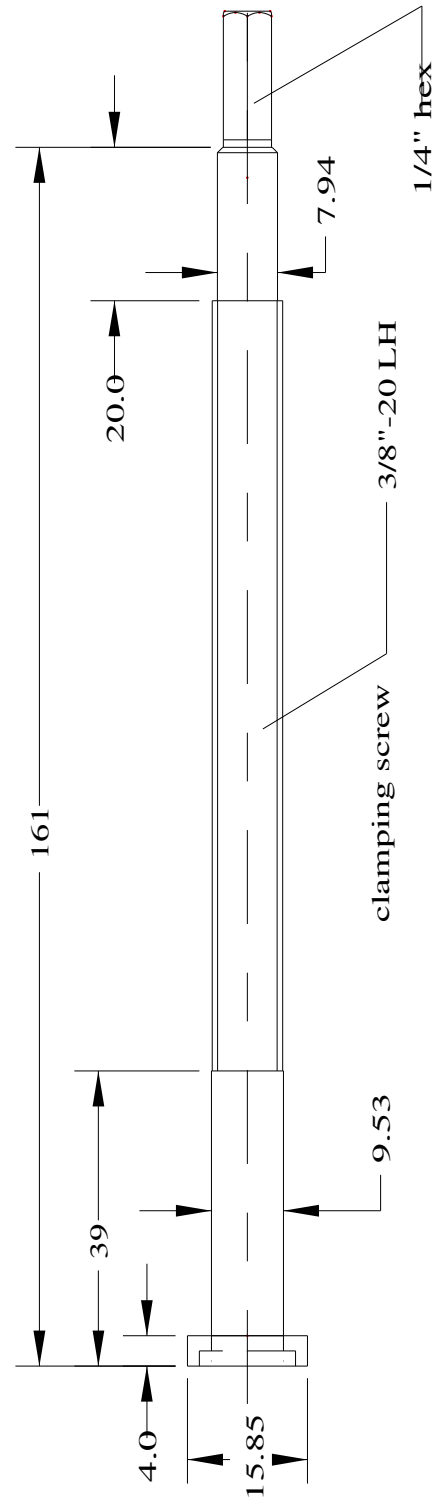
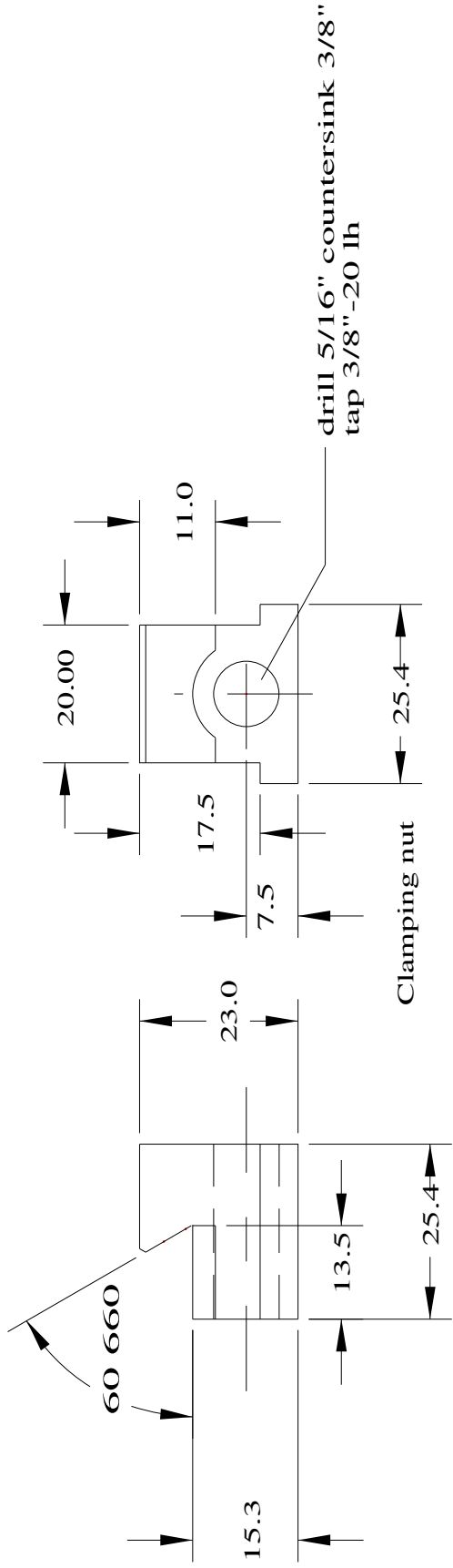

5cm vise

clamp screw

14.11.04

1:1

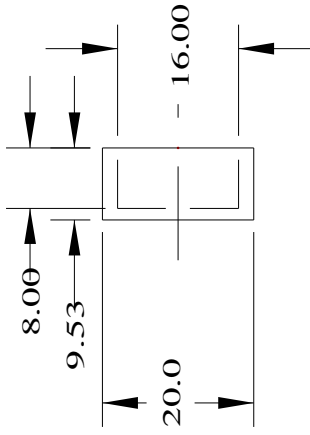

thrust bearing housing

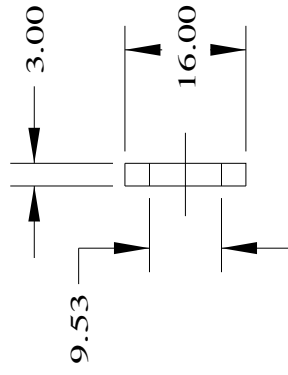
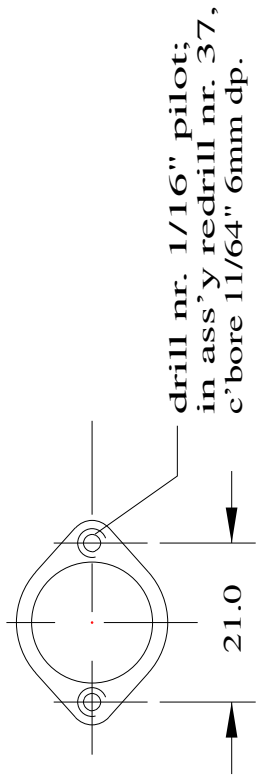

thrust bearing

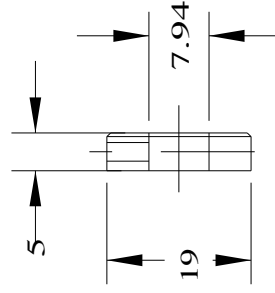

thrust collar

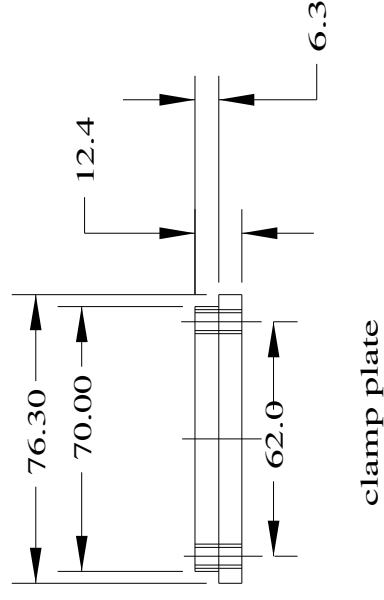
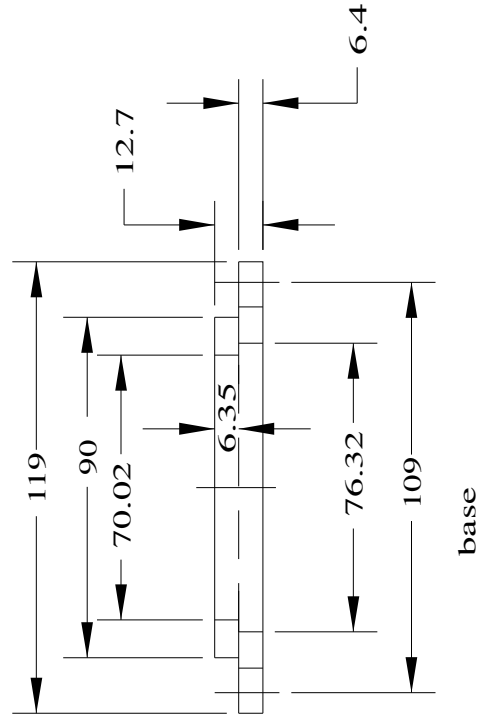
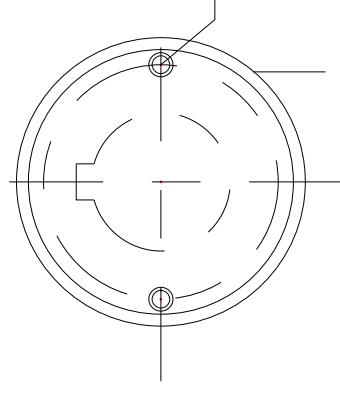
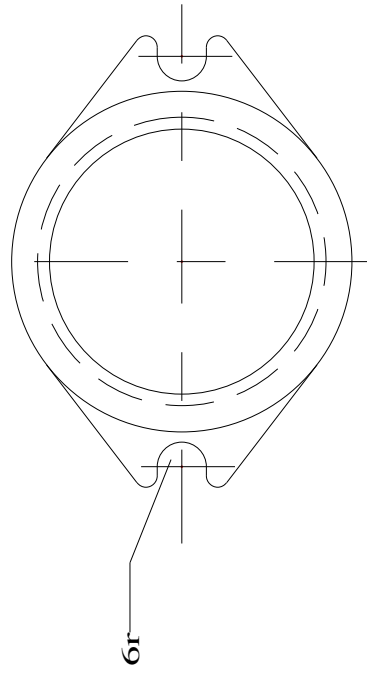

5cm vise

Swivel base

16.11.04

1:2